

De Havilland DH-88 Comet

de Havilland DH.88 Comet byl dvoumístný dvoumotorový letoun vyvinutý pro účast v závodu MacRobertson Air Race z Velké Británie do Austrálie v roce 1934.

Vývoj DH.88 Comet byl iniciován britským leteckým pionýrem Geoffrey de Havillandem, a předpokládá zkonstruování vítězného stroje a současně ověření nových konstrukčních postupů v praxi. Konstruktorem stroje byl A. E. Hagg, který design stroje podrobil specifickým požadavkům závodu. Výsledkem byl ladný stroj s uzavřenou kabinou, zatahovacím podvozkem a stavitelnými vrtulemi.

The de Havilland DH.88 Comet is a two-seat, twin-engined aircraft developed specifically to participate in the 1934 England-Australia MacRobertson Air Race from the United Kingdom to Australia.

Development of the DH.88 Comet was by Geoffrey de Havilland, with idea of producing the victorious aircraft as well as to gain from the research involved in producing it. The Comet was designed by A. E. Hagg around the specific requirements of the race;

Plastic parts

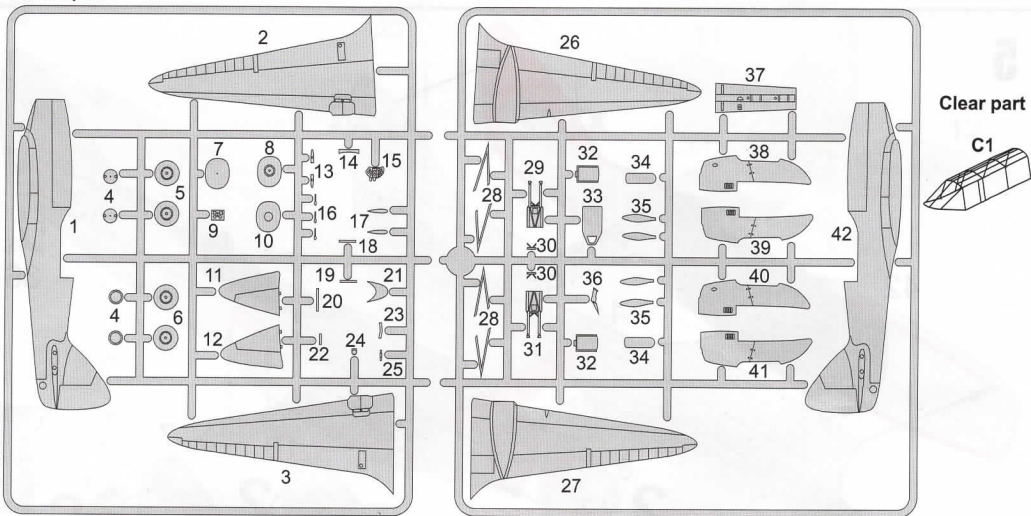

Symbols/Symboly

Drill hole Vývrtat	Cyanocrylate Vleťinové lepidlo	Remove Odstranit	Reduce Zbrousit
Make new Vyrobít	Option Volba	Bend Ohnout	Putty Tmel

	Colour name	Humbrol	Colour name	Humbrol
A	Black	H33	F	Natural Wood H110
B	Aluminium	H56	G	Gunmetal H53
C	Interior Green	H76	H	Tyre H85
D	Brown	H186	I	Rust H113
E	Linen	H74	J	Red Brown H100

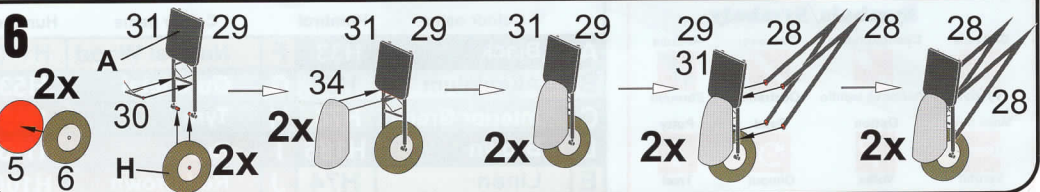
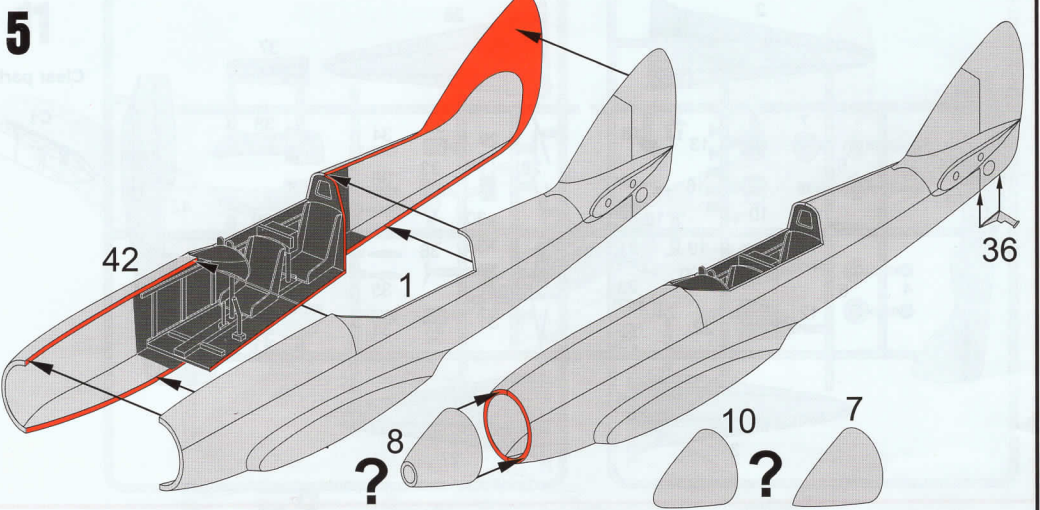
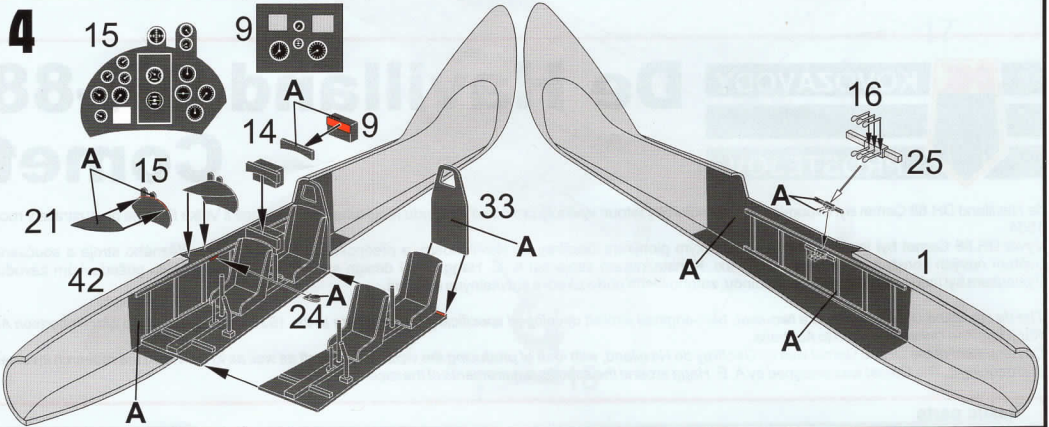
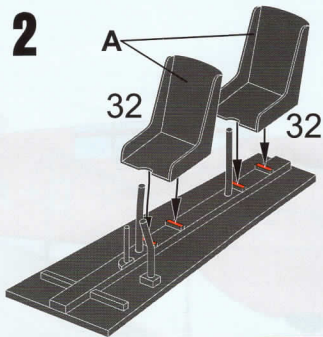
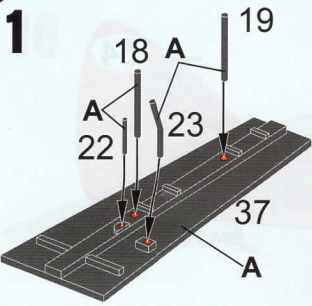

7

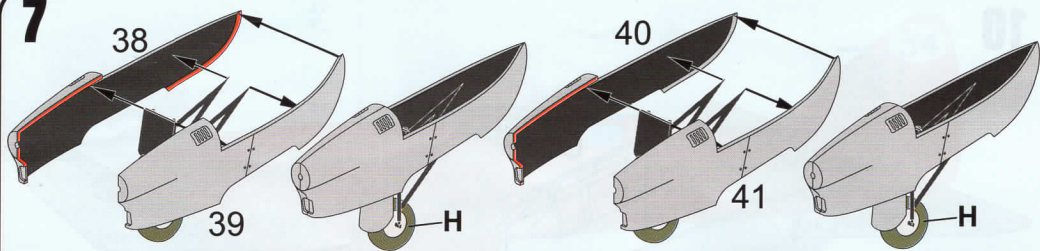

8

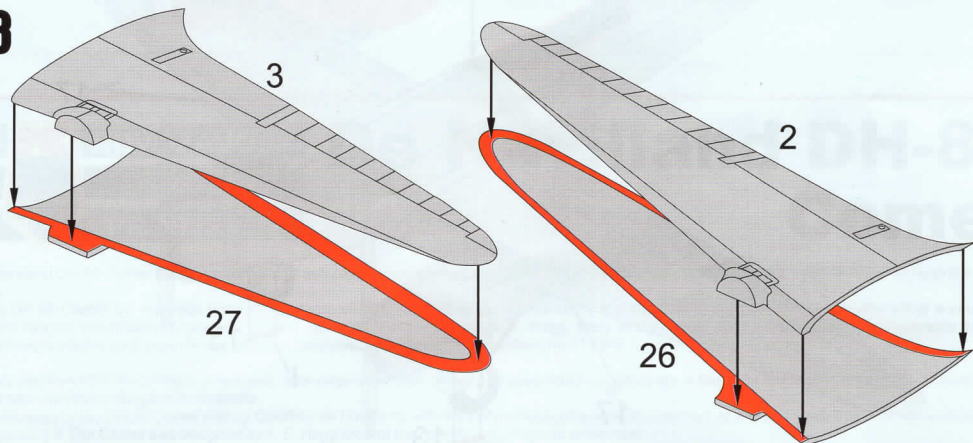

9

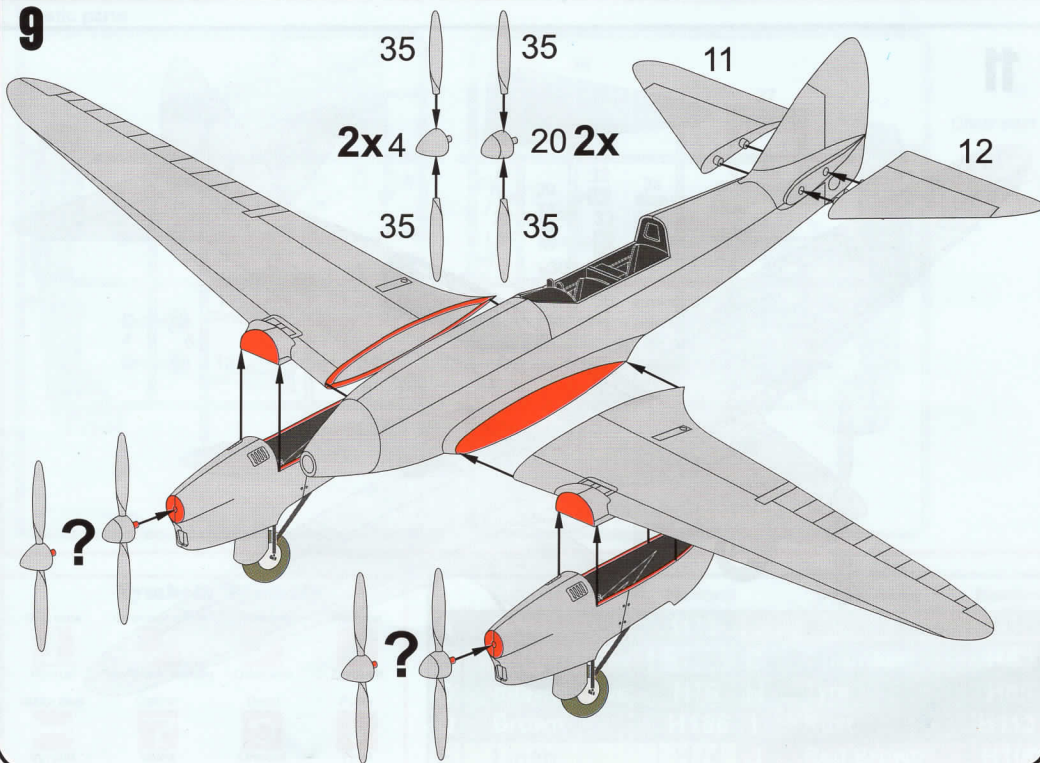

10

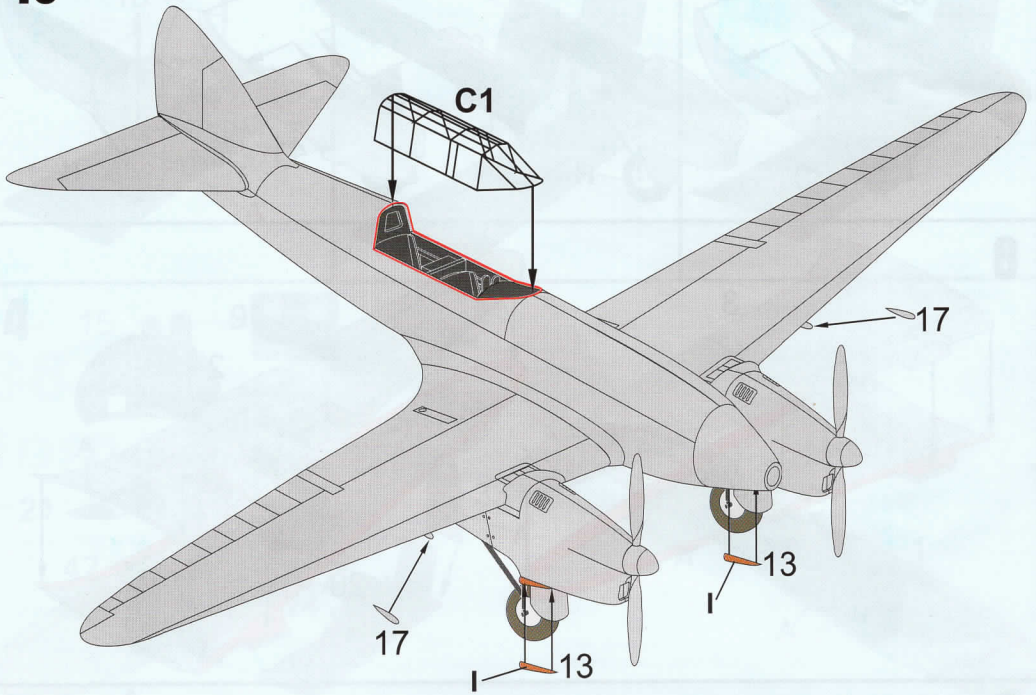

11

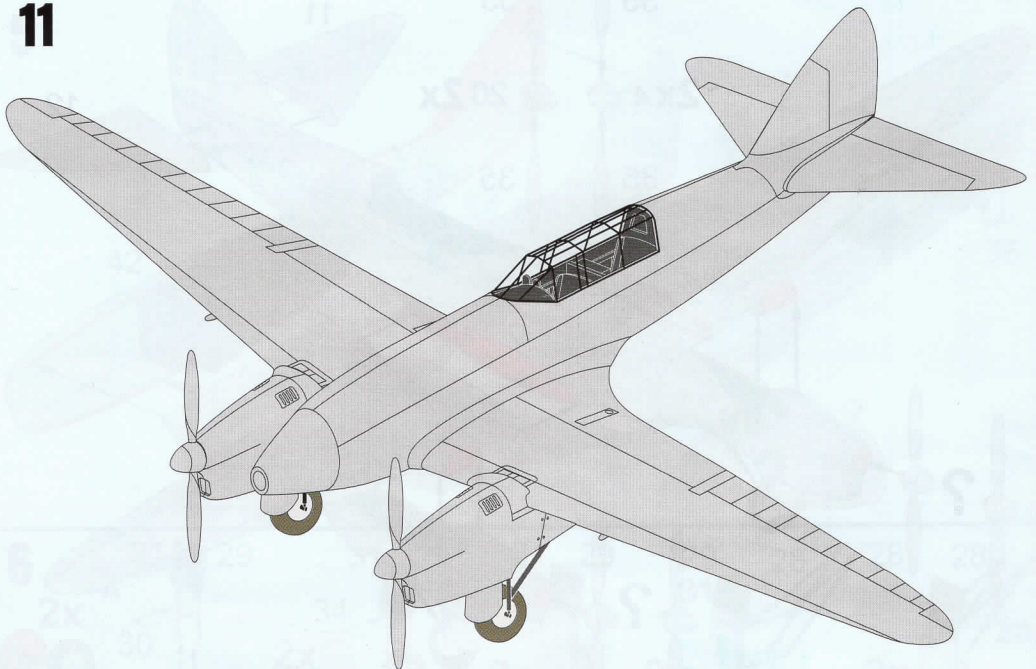

1 DH-88 Comet, E-109 (pravděpodobně), francouzské letectvo, 1939. Letoun zkušební ke spojovacím účelům, testy dopadly neúspěšně.

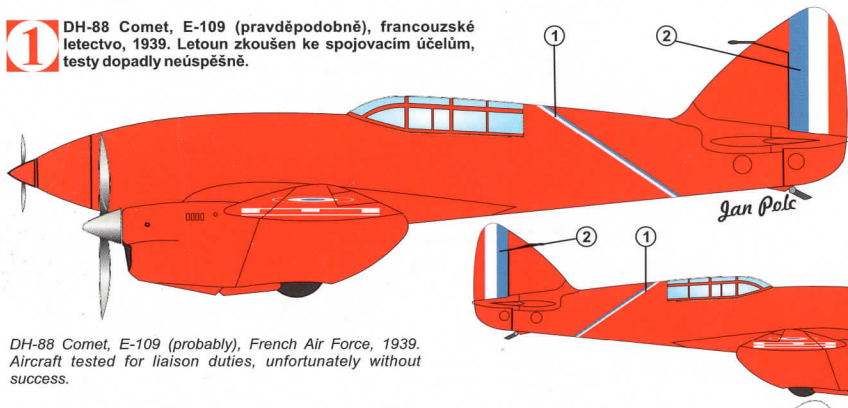

DH-88 Comet, E-109 (probably), French Air Force, 1939. Aircraft tested for liaison duties, unfortunately without success.

Zbarvení & Označení Colours & Markings

19 17L

Červená
Red

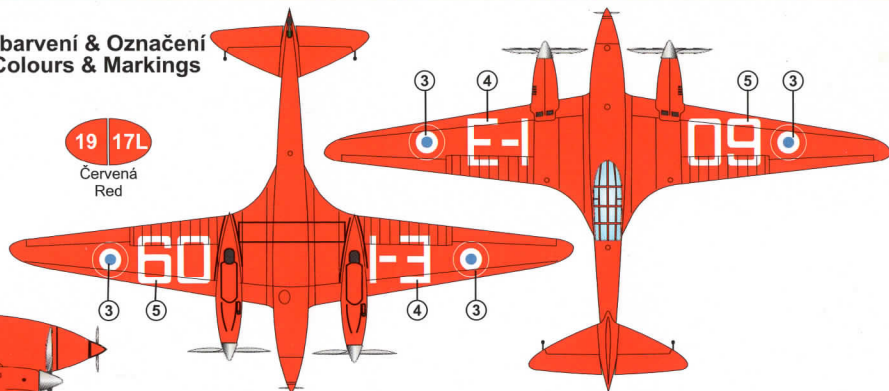

2 DH-88 Comet, K 5084, britské vojenské letectvo, 1939. Comet byl zkušební i britským vojenským letectvem. Během zkoušek létal zbarven stříbrnou na všech plochách.

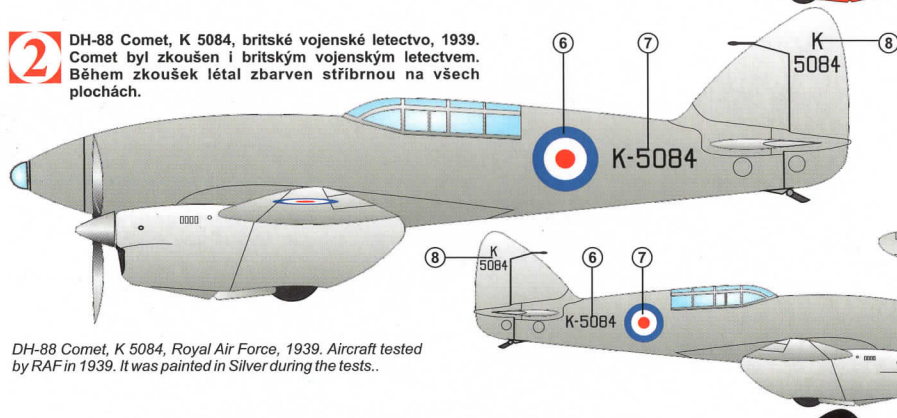

DH-88 Comet, K 5084, Royal Air Force, 1939. Aircraft tested by RAF in 1939. It was painted in Silver during the tests.

56 08

Stříbrná
Silver

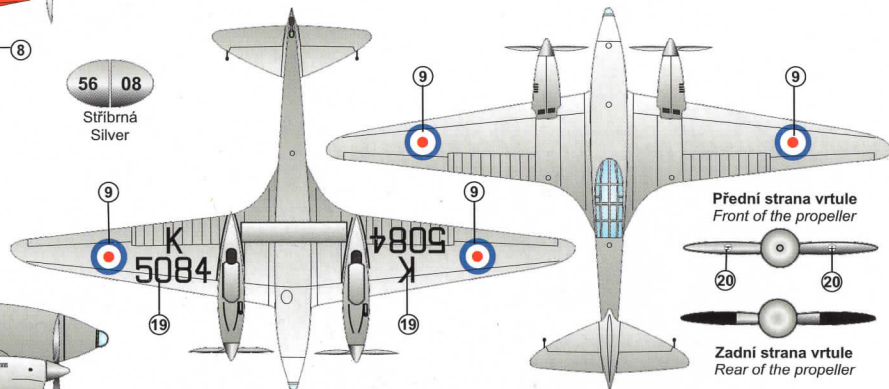

3 DH-88 Comet, CS-AAJ, Portugalsko, 1939. Comet pojmenovaný „Salazar“ létal v Portugalsku zbarvený černou barvou.

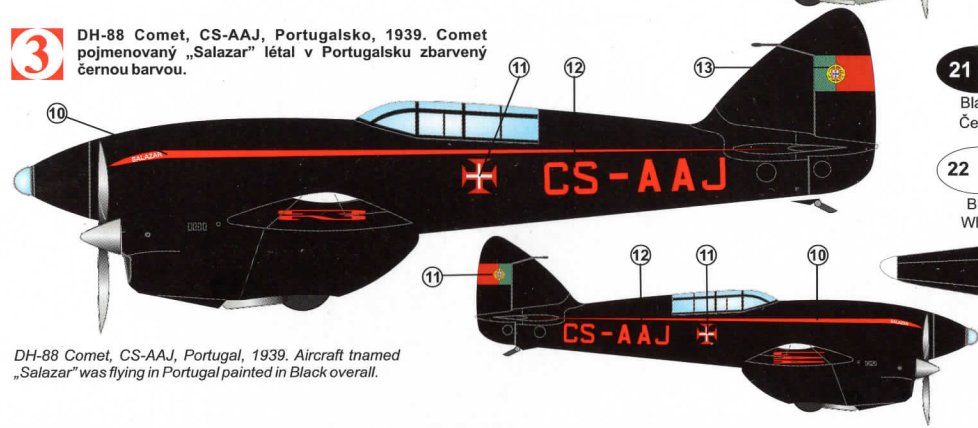

DH-88 Comet, CS-AAJ, Portugal, 1939. Aircraft named „Salazar“ was flying in Portugal painted in Black overall.

21 20L

Black
Černá

22 14

Bílá
White

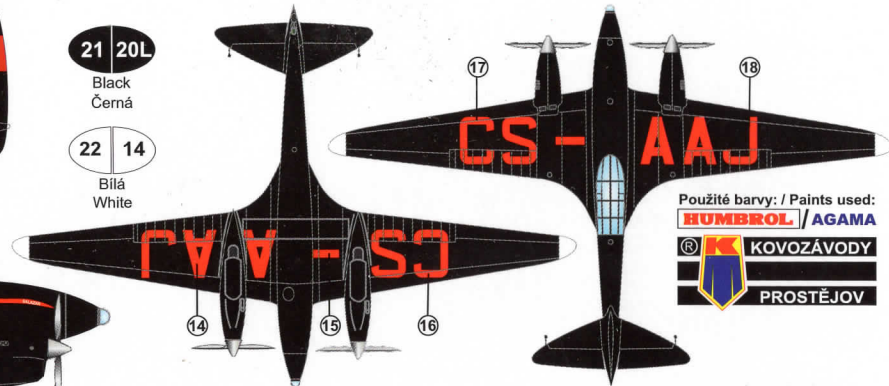

Použité barvy: / Paints used:

HUMBROL / **AGAMA**

KOVOZÁVODY

PROSTĚJOV