

**WITH
CEMENT**



REG. PRICE
45p
INC. VAT.

from 8 years

CAUTION : Cement is inflammable. Keep away from naked flame. Also keep away from eyes, nose and clothing.

SUPERMARINE SPITFIRE Mk 8/9

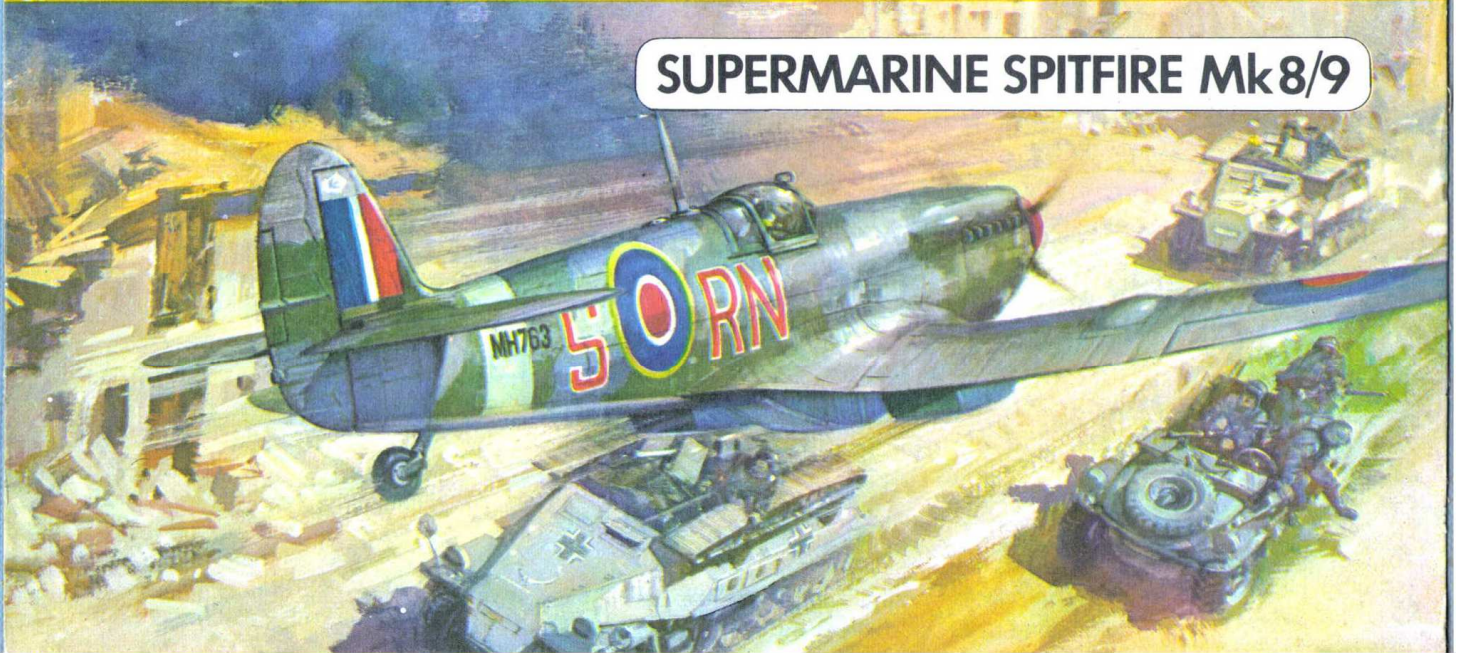

PROD NO.1016

MADE IN U.K.

SUPERMARINE SPITFIRE Mk 8/9

COLOUR PAINTING GUIDE

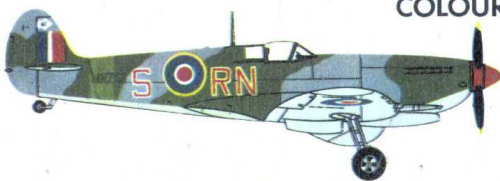

Spitfire Mk. IXc, flown by Flt. Lt. Prince Emanuel Galatzine, No. 72 Sqn., 324 Wing, R.A.F. Operation Dragoon, Southern France, August 1944.

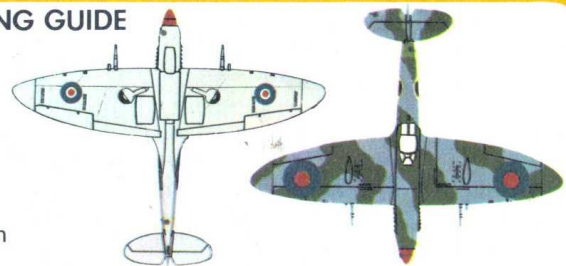

Spitfire Mk. VIII, flown by Sqn.Ldr. Bruce Watson, Officer Commanding No. 457 Sqn., R.A.A.F., Morotai Island, S.W. Pacific, early 1945.

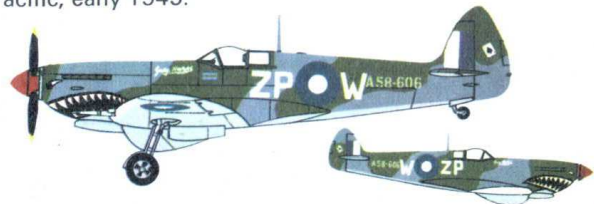
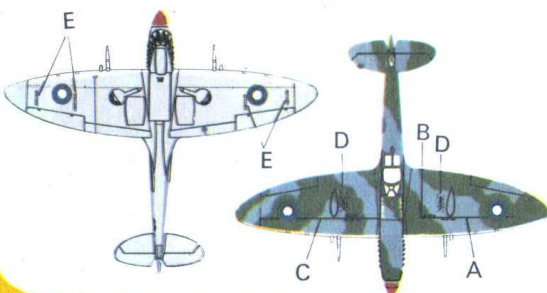

The Remus name and logo style are Registered Trade Marks.

Remus Play-Kits, P.O. Box 47, Slough, SL1 4LS, England.

©1975, REMUS PLAY-KITS

SUPERMARINE SPITFIRE Mk VIII or Mk IX

Single seat fighter 1:72 scale

The most famous British plane of World War 2, the Spitfire, was eventually produced in over 20 different Marks. The Mark 8 was designed to take the Merlin 61 engine with its two-speed, two-stage supercharger and was intended to take on the high-flying F.W. 190s which were then outclassing the earlier Spitfire 5s. The 9 came out before the 8, being basically an adaptation of the 5 with the 61 engine. Engine: 1,520 h.p. Rolls Royce Merlin 61. Max. speed: 408 m.p.h. at 25,000 ft. Service ceiling: 43,000 ft. Armament: two 20 mm cannon and four .303 machine guns.

To complete the aircraft as illustrated, you will need model aircraft paint. A display stand is not supplied with this model.

10 MODEL TIPS

If you desire to paint, use appropriate model aircraft paints, taking as a guide either of the two illustrations, which are to be found under the front blister. Use the illustrations for correct selection and positioning of the transfers.

Caution

Polystyrene cement is highly inflammable. Keep away from naked flame, and also from the face - particularly the eyes and nose - and from clothing. Use pin to open tube and replace after use. Use sparingly.

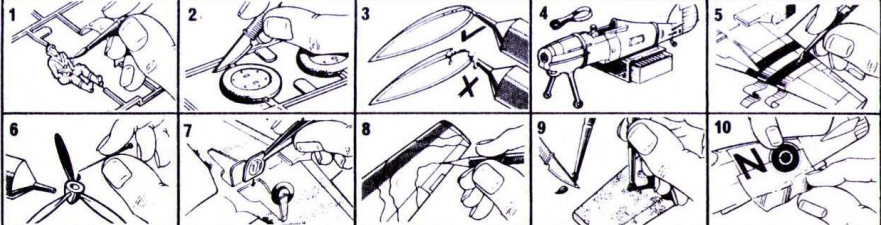

Instructions Test assembly position and fit of parts before cementing. Assemble in sequence shown i.e. A, B, C, D, etc. Note that the part numbers needed for each step are listed in the recommended assembly sequence.

Special Instructions Note the importance of locating the undercarriage lugs (Diag. C) before cementing wing sections together (Diag. D). Silhouettes denote different undercarriage positions for the various Marks.

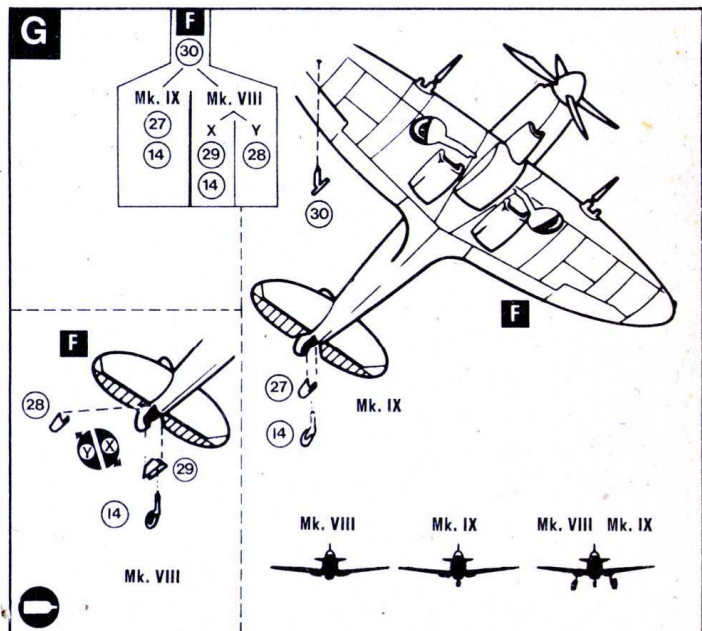
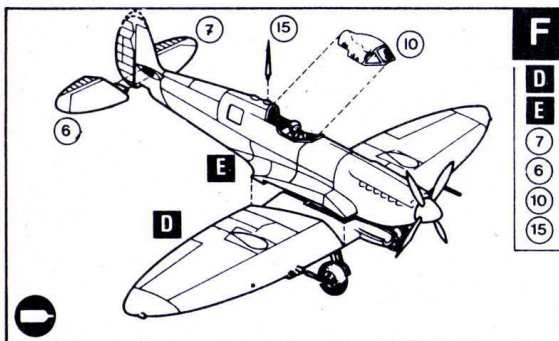
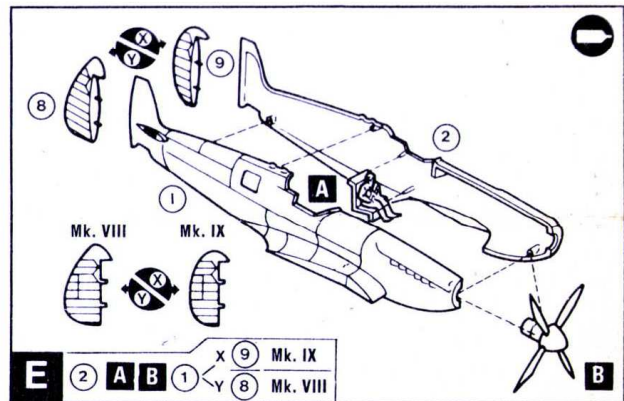
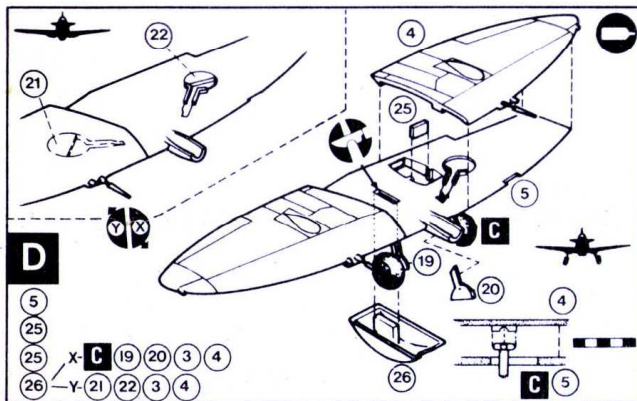
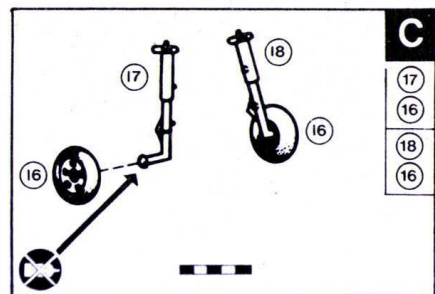
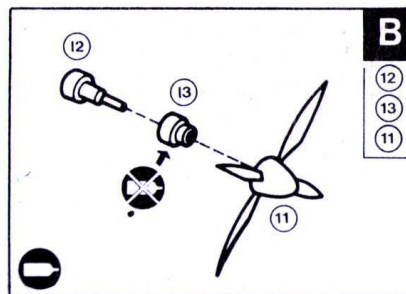
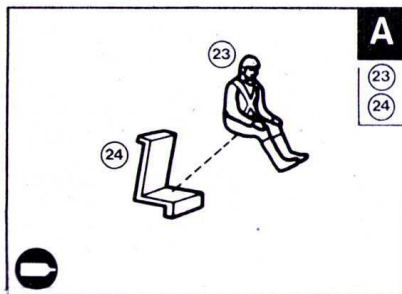

PLEASE USE BLOCK LETTERS

NAME _____

ADDRESS _____

Supermarine Spitfire Mk. VIII or Mk. IX

Part No. _____

In the event of a missing or faulty part, fill in your name, full address and the part number here. Cut around the dotted line, and return the complete slip to the address shown below.

