

PLEASE OPEN CAREFULLY — INSTRUCTIONS OVERLEAF

The Hawker Hurricane, the first monoplane fighter to enter service with the R.A.F., shouldered the lion's share of Britain's defence during the "Battle of Britain" and together with the "Spitfire" was responsible for the successful outcome of this conflict. During the Second World War many versions of the Hurricane appeared, some 14,000 being built in all. This particular version, the Hurricane IV R.P., first appeared in 1943, and was used both in Europe and the Middle East. It was primarily a ground attack aircraft, its rockets being particularly effective against armoured vehicles and strong points. The Hurricane had a wing span of 40 ft., and overall length of 32 ft. 3 ins. and a maximum speed of approximately 340 m.p.h. It was armed with eight rocket projectiles.

HAWKER HURRICANE IV R.P.



AIRFIX - 72 SCALE

HURRICANE IV

HAWKER HURRICANE IV R.P.

INSTRUCTIONS

PAINT ALL DETAILS AND LET DRY BEFORE ASSEMBLING (SEE SECTION 4)
N.B. FOR PAINTING USE "AIRFIX" PAINTS, FOR FIXING USE "AIRFIX" POLYSTYRENE CEMENT

1 FUSELAGE ASSEMBLY

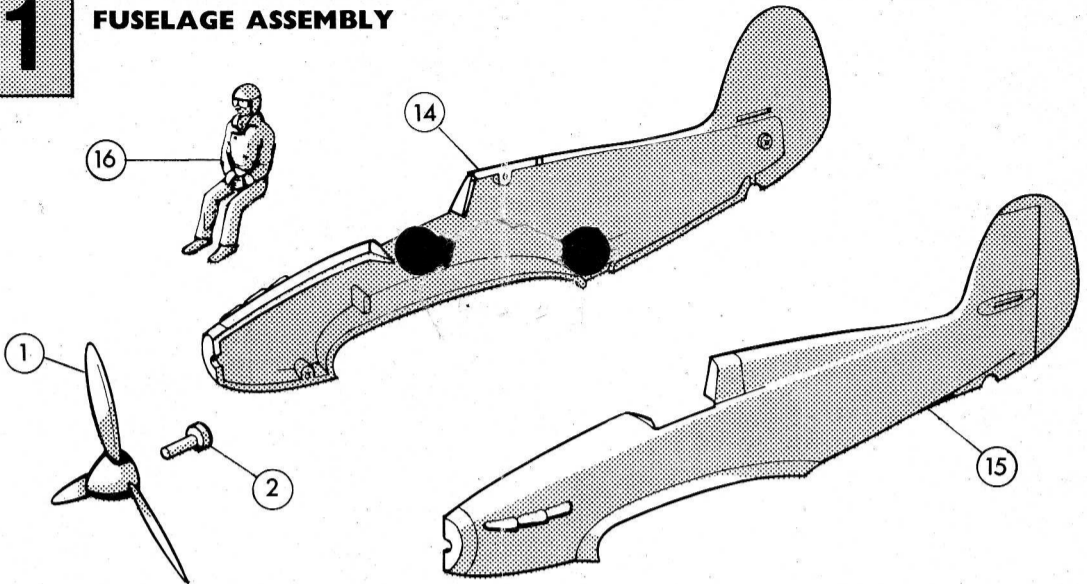

NOTE:—It is recommended that the instructions and exploded view are studied and assembly practised before cementing together. Wherever possible parts should be painted before assembly.

1. Cement propeller shaft (2) into propeller (1) and allow to dry.

2. Cement pilot (16) onto support in starboard fuselage half (14).

3. Place, DO NOT CEMENT, propeller shaft in cut out in nose of starboard fuselage half, then cement starboard fuselage half to port (15) ensure propeller is free to rotate.

2 WING & TAILPLANE ASSEMBLY

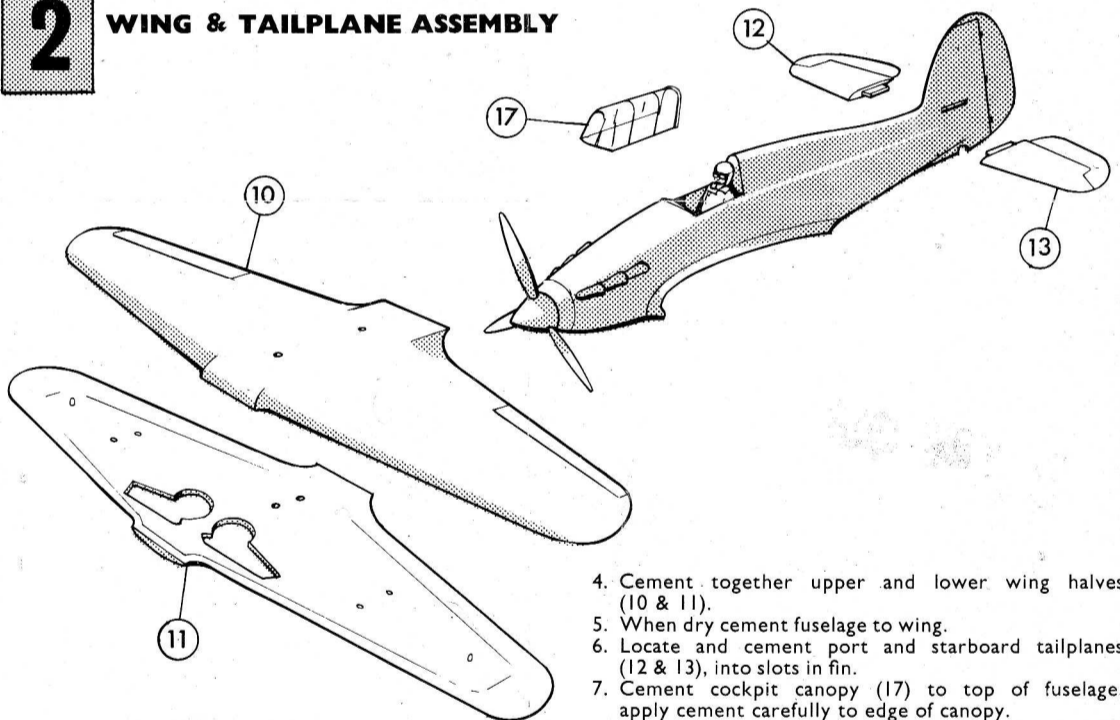

4. Cement together upper and lower wing halves (10 & 11).

5. When dry cement fuselage to wing.

6. Locate and cement port and starboard tailplanes (12 & 13), into slots in fin.

7. Cement cockpit canopy (17) to top of fuselage, apply cement carefully to edge of canopy.

3 UNDERCARRIAGE ASSEMBLY

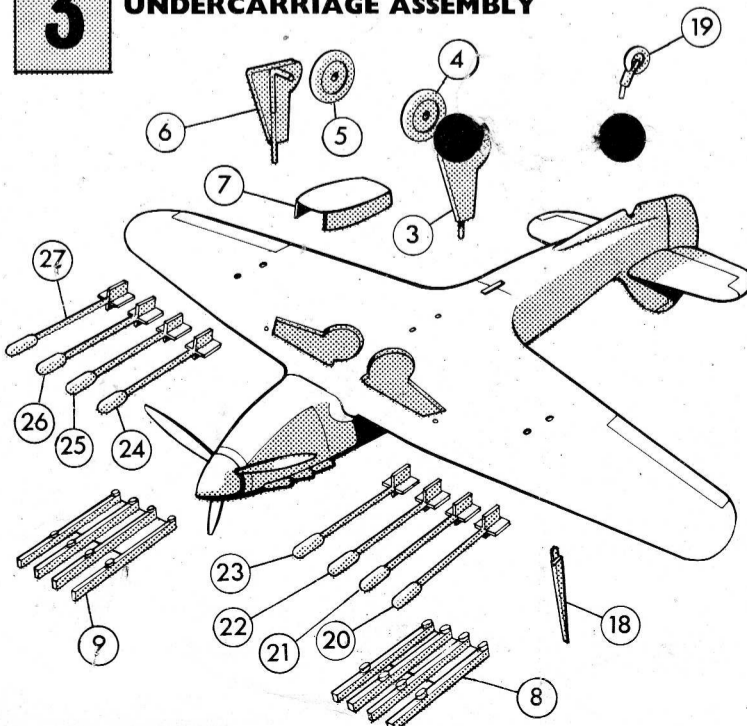

8. The desired undercarriage must now be selected. For a model with lowered undercarriage position and cement wheels (4 & 5) onto axles on undercarriage legs (3 & 6).

9. Cement undercarriage legs into locating holes beneath wing.

10. Locate and cement tail wheel (19) into locating hole beneath rear of fuselage.

11. Should a retracted undercarriage be desired cement wheels and legs into wheel wells in closed position.

12. Locate and cement radiator (7) centrally beneath wings.

13. Locate and cement rocket rails (8 & 9) beneath port and starboard sides of wing.

14. Locate and cement rockets (20-27) in position on launching rails.

N.B. The rockets and rocket rails may be omitted and the aircraft completed as a standard fighter.

15. Locate and cement radio antenna (18) to locating hole in top of fuselage.

16. NOTE:—IF IT IS WISHED TO PAINT THE MODEL IT SHOULD BE DONE AT THIS STAGE.

4

SUGGESTED COLOUR SCHEME

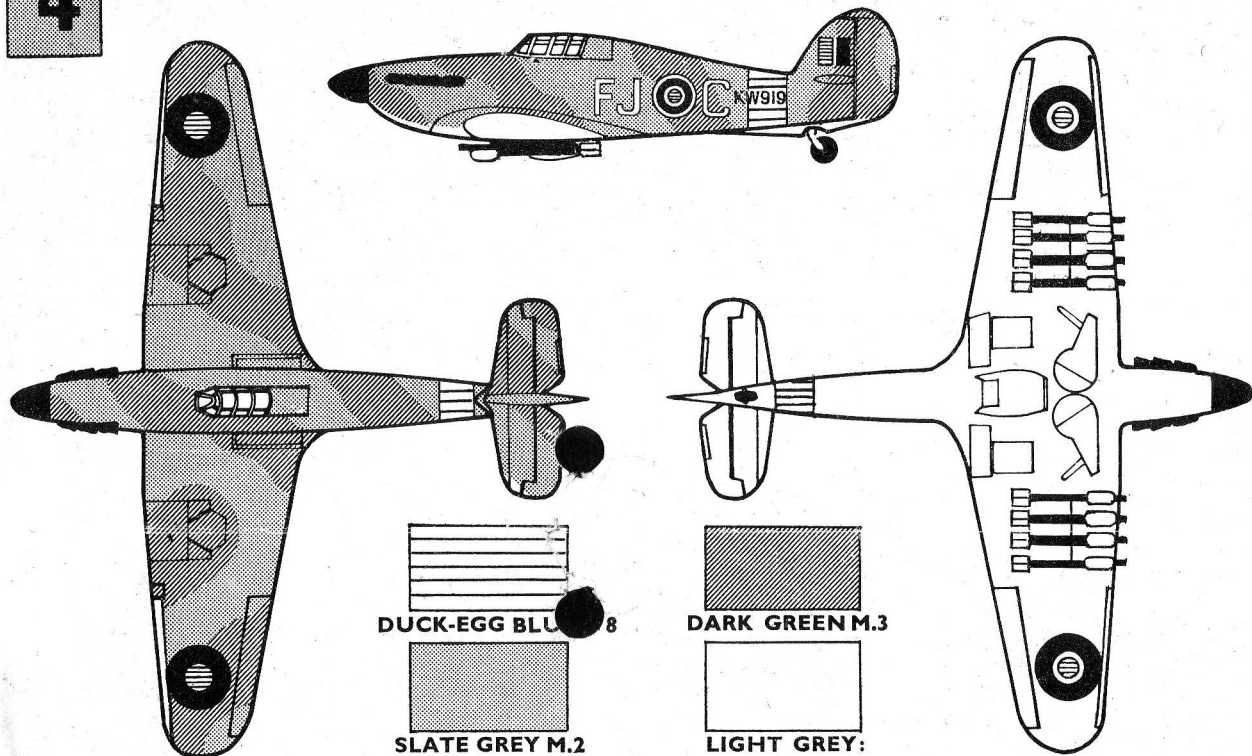

Apply transfers. First cut the sheet into eleven separate subjects. Then dip each in warm water for a few minutes, slide transfer off backing into position as indicated on illustration. The red and blue roundels are applied above the wing, the red, white and blue beneath the wing. The smaller roundels and their attached squadron markings are applied to the fuselage sides. The aerial number is applied to the rear of the fuselage, and the red, white and blue flashes to the fin, and the red, white and blue forward. The aircraft name is applied to the transparent base.

17. Cement together both parts of stand.
18. Cement arm of stand into slot provided in fuselage.

SLATE GREY M2 All upper surfaces, fuselage sides.

DARK GREEN M3 Irregular stripes over dark grey to give camouflaged effect.

LIGHT GREY All undersurfaces, undercarriage, rocket heads
BLACK M6 Propeller and spinner, exhaust outlets, tyres, rocket rails, bodies of rockets.

DUCK-EGG BLUE M8 band around rear fuselage.
YELLOW G2. outboard leading edges of wings,