

N. A. T. 28

Réf: 279

FENNEC



10

5

9

5

10

TL371

CIC H HALL



11



12

TL371



2

2



4

51-3557

FENNEC N° 43

8

38371

6



1



13



7



1

8

38371

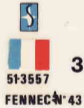

3

51-3557

FENNEC N° 43

Heller

NORTH AMERICAN T 28

HISTORIQUE

Conçu à l'origine comme avion d'entraînement, destiné à remplacer le T-6 TEXAN, le T-28 TROJAN par ses qualités est très vite devenu un avion d'arme spécialisé pour l'appui-feu au sol. Il fut dans cette nouvelle carrière aux mains des pilotes français pendant la guerre d'Indochine puis continua avec les guerres de mercenaires en AFRIQUE et au VIETNAM, où il se montra supérieur à ses homologues américains.

HISTORY

Designed originally as a training aircraft, intended to replace the T-6 TEXAN, the T-28 TROJAN as a result of its qualities soon became a combat plane specialized in supporting ground fire. It started its new career in the hands of French pilots in French North Africa and carried on in the mercenary wars in AFRICA and VIETNAM, where it proved itself superior to its supersonic opposite numbers.

HISTORISCHES

Der T-28 TROJAN war ursprünglich als Schulflugzeug entwickelt worden und sollte die T-6 TEXAN ersetzen. Aufgrund ihrer Qualitäten wurde sehr schnell ein spezialisiertes Waffengeflugzeug für die Unterstützung der Bodengebilde. Sie begann dieses neue Leben in den Händen der französischen Piloten in A.F.N. und setzte sie dann mit den Soldaten in AFRIKA und VIETNAM fort, wo sie sich den Überschallflugzeugen für die gleichen Aufgaben als überlegen erwies.

HISTORIAL

Disegnado en un principio como avión de entrenamiento, destinado para ocupar el sitio del T-6 TEXAN, el T-28 TROJAN por sus cualidades se convirtió, muy pronto, en avión de armas especializado para el apoyo de fuego en tierra. Inicialmente en manos de los pilotos franceses en la guerra de Indochina y en el VIETNAM, en donde se mostró superior a sus homólogos americanos.

CARACTERISTIQUES

Envergadura : 12,21 mètres
 Longueur : 9,75 mètres
 Hauteur : 3,85 mètres
 Moteur : 1 WRIGHT R - 1300 de 800 CV
 Vitesse maximum : 530 km/h
 Plafond : 7500 mètres

DATA

Span : 12,21 metres
 Length : 9,75 metres
 Height : 3,85 metres
 Engine : 1 WRIGHT R - 1300 - 800 HP
 Maximum speed : 530 km p.h.
 Ceiling : 7500 metres

KENNDATEN

Spannweite : 12,21 Meter
 Länge : 9,75 Meter
 Höhe : 3,85 Meter
 Motor : 1 WRIGHT R - 1300 von 800 PS
 Höchstgeschwindigkeit : 530 km/h
 Maximale Flughöhe : 7500 Meter

CARACTERISTICAS

Envergadura : 12,21 metros
 Longitud : 9,75 metros
 Altura : 3,85 metros
 Motor : 1 WRIGHT R - 1300 de 800 CV
 Velocidad máxima : 530 km/h
 Techo : 7500 metros

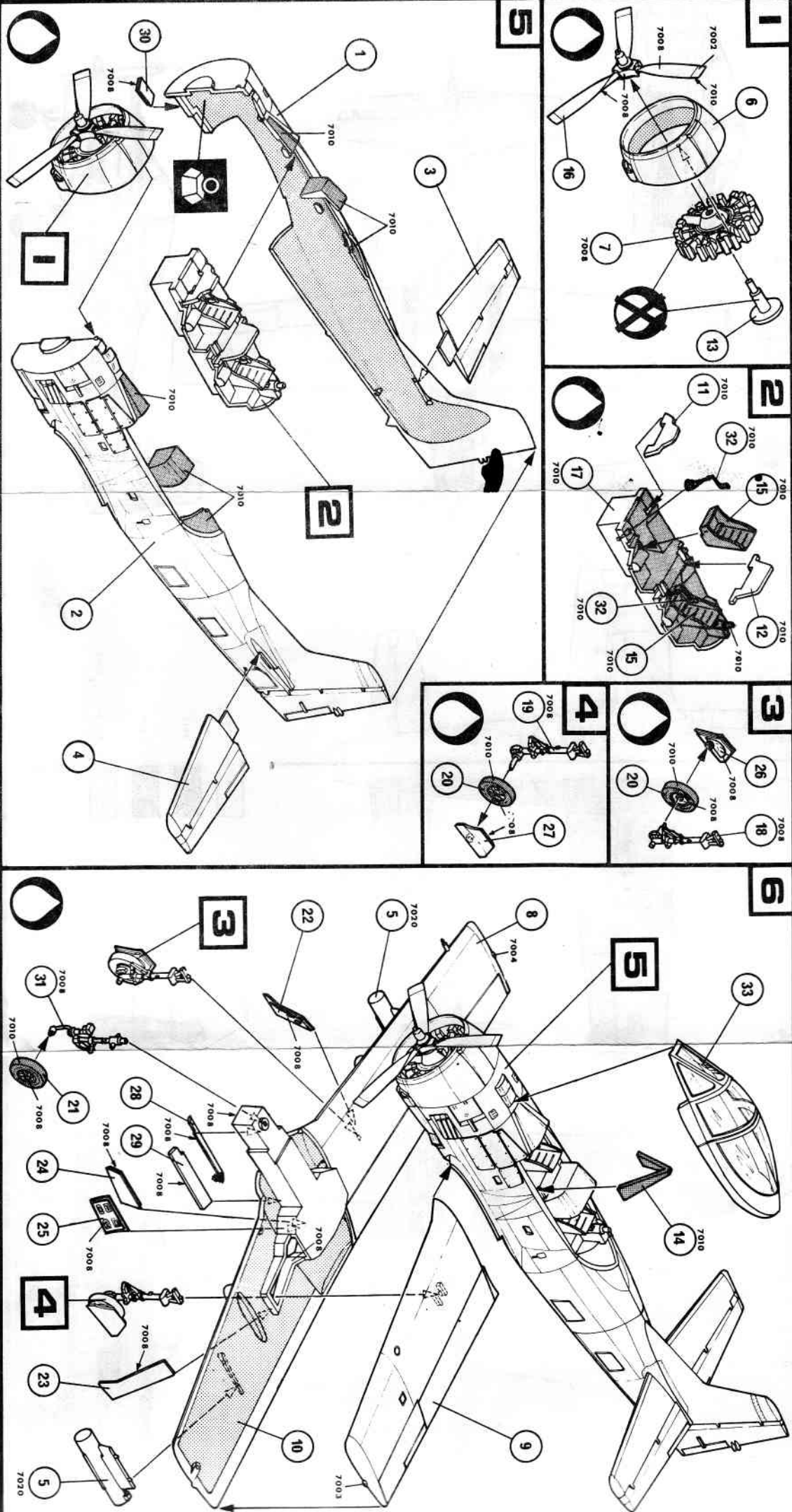

VIET NAM - 1st Air commando 1963.

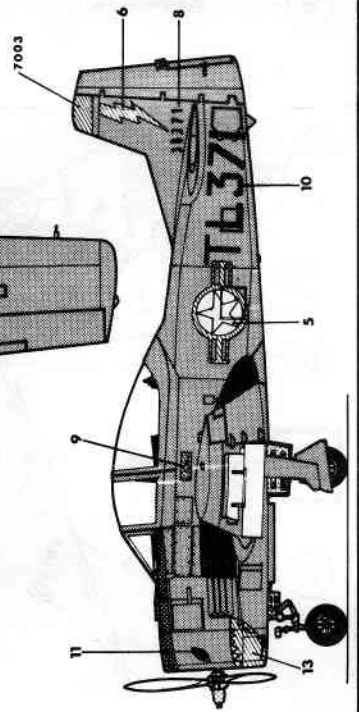
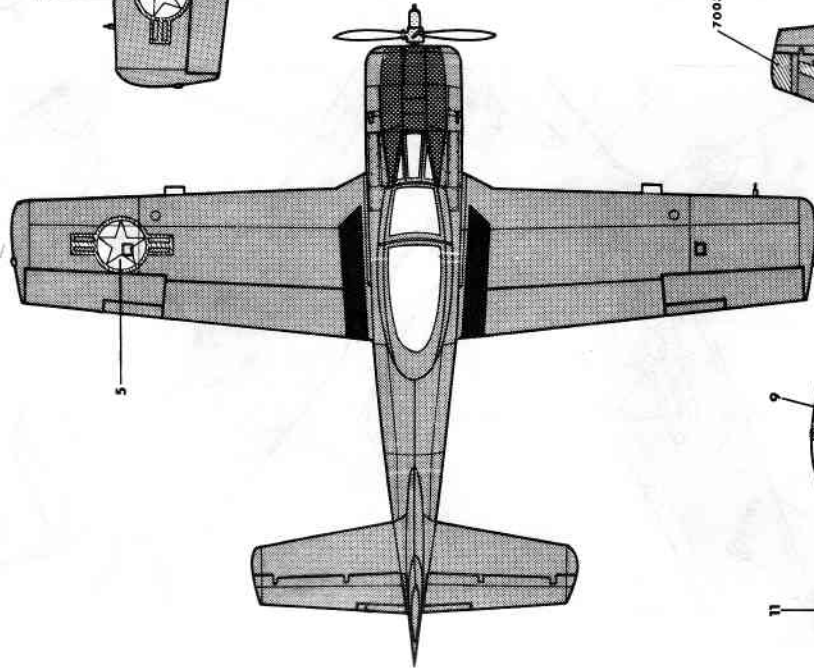
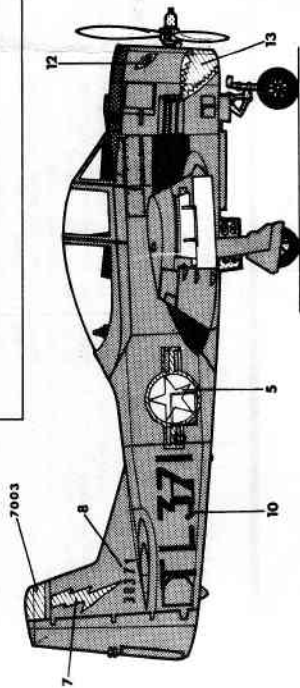

FRANCE - E.A.L.A. 2/72 Algérie 1960.

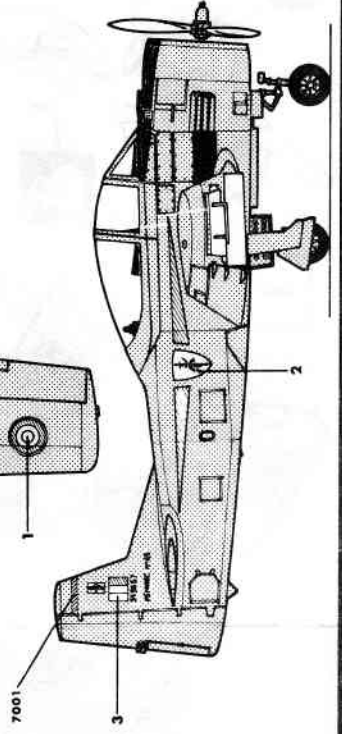
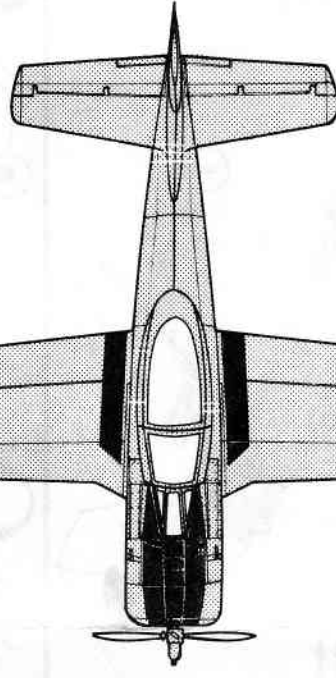
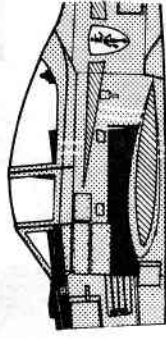
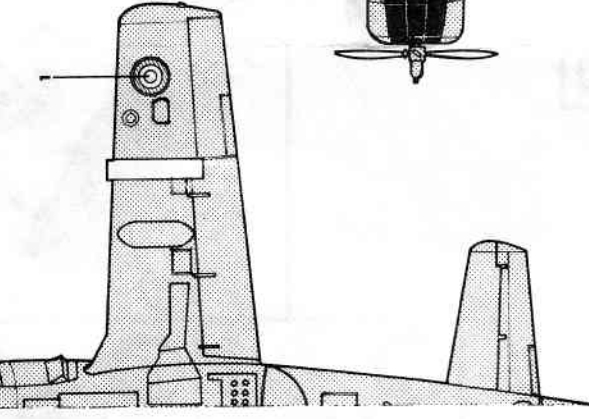
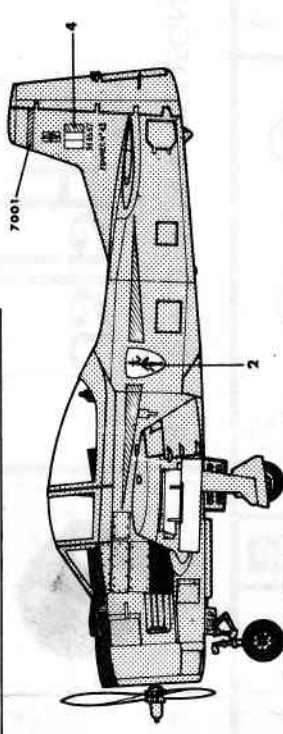

- 7008
- 7010
- 7030
- 1/2 7001 + 1/2 7020

