SH 72050
Fairey Firefly T.1/T.2
1/72

(CZ) Letoun Fairey Firefly byl navržen podle specifikace Britské Admirality N.5/40, která vyžadovala náhradu za dvoumístný stíhači-průzkumný letoun Fairey Fulmar. Předběžné návrhy byly vypracovány v září 1939 a první ze čtyř prototypů vzletl 22. 12. 1941. Následovaly zkušební lety včetně zkoušek na palubě letadlové lodi HMS Illustrious koncem roku 1942. První sériové stroje Firefly Mk. I určené pro operační nasazení u jednotek Britského námořního letectva (FAA) byly dodány v březnu 1943, a do operační služby se dostaly 1. 10. 1943, kdy byly zařazeny do výzbroje 1771. squadrony RNAS v Yeoviltonu. Letoun Firefly byl prvním Britským námořním letounem, který měl jako pohonnou jednotku motor Rolls Royce Griffon II. Instalace tohoto motoru umožnila, aby nový letoun Firefly měl mnohem lepší výkony, než jeho předchůdce, letoun Fairey Fulmar. Také se značně zlepšilo ovládání jak při startu z paluby letadlové lodi, tak za letu. Letoun nesl i silnější výzbroj, a to čtyři kanony ráže 20 mm. Po dokončení úvodní výrobní série verze F.Mk. I (459 kusů), bylo dalších 236 kusů modifikováno na verzi FR.Mk. I s radarem ASH umístěným pod motorem. Továrna Fairey také experimentovala s přípravou noční stíhači verze pod označením NF. Mk. II, která měla o 38 cm delší trup za požární přepážkou motoru, a která byla vyzbrojena radarem AI Mk. X. Prototyp této verze se však neosvědčil a od výroby této verze se upustilo. Protože se ukázalo, že letouny FR.Mk. I s radarem ASH jsou schopné plnit také úlohy nočního stíhače, bylo 140 kusů této verze vyrobeno pod označením NF.Mk. I. Letouny Firefly Mk. I se osvědčily při bojových operacích v Evropě a na Dálném východě. Na Evropském bojišti se letouny Firefly s úspěchem zúčastnily řady útočných a výzvědných operací podél pobřeží Norska. Letouny startovaly z paluby letadlové lodi HMS Implacable. Nejznámější operací byl útok na německou loď Tirpitz kotvící v Altenfjordu. Teprve však při operačním nasazení proti Japoncům na Dálném východě se letouny Firefly Mk. I plně osvědčily i při vzdušných bojích, kdy startovaly z letadlové lodi HMS Indefatigable. V lednu 1945 letouny Firefly vyzbrojené raketami doprovázely bombardéry Grumman Avenger při útoku proti naftovému rafinerii obsazených Japonci na ostrově Sumatra. Letouny Firefly 1772. Squadrony FAA byly také prvními Britskými letouny, které dne 24. 8. 1945 přelétly nad Tokiem.

Těsně po ukončení války začaly práce na cvičné verzi Firefly. Prototyp s civilní registrací G-AHYA vzletl v červenci 1946. Přestavěn byl ze standardní Firefly sériového čísla MB473. Na základě úspěšných testů a předvádění v leteckých školách ve Velké Británii, Francii a Holandsku byly objednány sériové stroje. Byly přestavěny také ze standardních Firefly Mk. I. Produkovány byly ve dvou verzích, neozbrojené T.1 (30 kusů) a verzi T.2 se dvěma kanony (54 kusů). Několik dalších kusů bylo upraveno v Holandsku a Kanadě.

Technické údaje: Rozpětí 13,60 m. Délka 11,50 m. Max. rychlost 509 km/hod ve výšce 4265 metrů. Normální dolet 1245 km. Operační dolet 8535 m. Výzbroj: 2 kanony Hispano ráže 20 mm (pouze verze T.2)

(GB) The Fairey Firefly was designed to the British Admiralty Specification N.5/40; which called for a two-seat reconnaissance fighter to replace the Fairey Fulmar. The preliminary designs were completed in September 1939 and the first of four prototypes flew on 22nd December 1941. Following further testing, carrier trials were carried out aboard HMS Illustrious at the end of 1942. The first operational aircraft were then delivered to the Fleet Air Arm by March 1943, becoming operational with 1771 Sqn at RNAS Yeovilton on 1st October 1943. With its distinctive elliptical-shaped wing and "chin" radiator, the Firefly was the first Fleet Air Arm aircraft to employ the Rolls Royce Griffon II engine. This powerplant gave the Firefly much higher performance than the Fulmar and made it easier to handle on the flight deck as well as in the air. The four 20mm cannon armament also gave it a much greater "punch" than its predecessor. Following the initial production run of 459 Firefly F.Mk. Is, a further 236 were modified by fitting an ASH radar pod under the engine. This variant became known as the Firefly FR.Mk. I (R standing for "Reconnaissance"). Fairey then experimented with a night-fighter version of the Firefly, firstly producing a number of NF.Mk. II aircraft, which had a 15 inch (0.38 metre) extension behind the engine firewall and was fitted with the AI Mk. X radar. This proved to be unsuccessful and difficult to handle, so 140 FR.Mk. I aircraft were designated as NF.Mk. Is, as their ASH radar proved to be suited to the Airborne Intercept role. In the European Theatre of Operations, the Firefly's most notable success was on maritime strike and reconnaissance missions along the coast of Norway, flying from HMS Implacable. The most famous mission was against the German battleship Tirpitz in Alten Fjord, which eventually led to the RAF raid, which sank the battleship. It was, however, in the Far East that the Firefly was to prove a very able air-to-air combat aircraft, flying against the Japanese, from HMS Indefatigable. In January 1945, rocket-firing Fireflies joined Grumman Avenger bombers on a raid against a Japanese-held oil refinery on Sumatra and on 24th July 1945, the Fireflies of 1772 Sqn were the first British aircraft to fly over Tokyo.

Just after the end of the war the design works on the Firefly trainer began. The maiden flight of the prototype bearing civil registration G-AHYA took part in July 1946. It was converted from Firefly serial no. MB473. The batch production was ordered in virtue of successful flight trials performed in flying schools in Great Britain, France and Holland. These were also converted from standard Firefly Mk. Is. Two versions were produced, unarmed version designated T.1 (30 produced) and version T.2 (54 produced) equipped with two cannons. Several other aircraft were modified in Holland and Canada.

Technical Specifications: Span 44 ft 6 in (13.6m). Length 37ft 7in (11.5m). Maximum speed was 316mph (509km/h) at 14,000ft (4,265m). Normal Range was 774 miles (1,245km). Service ceiling was 28,000ft (8,535m). Armament consisted of two 20mm Hispano cannon (T.2 only).

PARTS - DÍLY

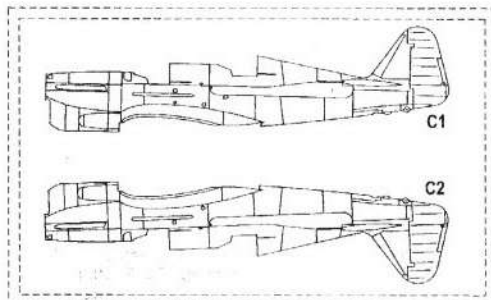
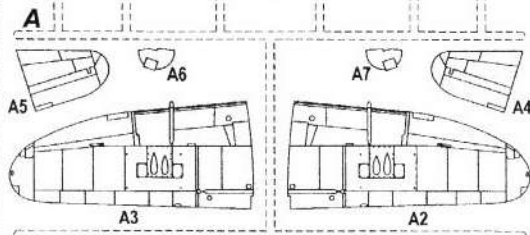
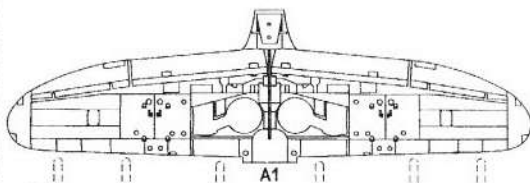

C

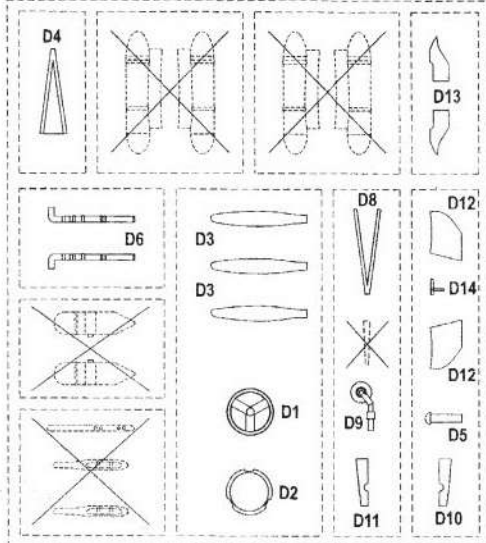
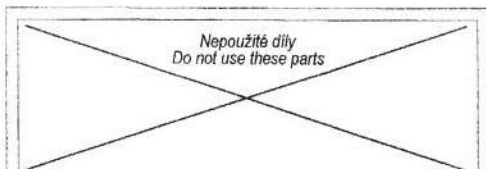

D

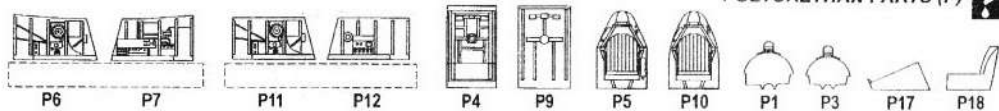

POLYURETHAN PARTS (P)

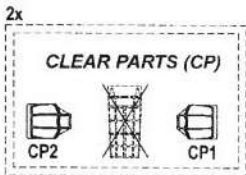
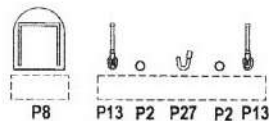
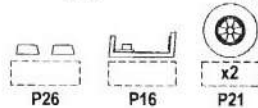
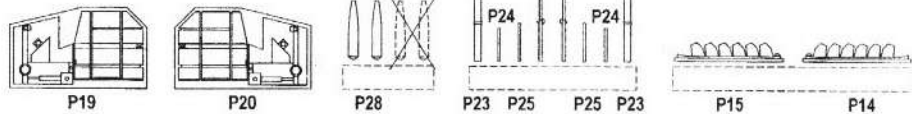

CLEAR PARTS (CP)

PHOTO-ETCHED PARTS (L) **Film (F)**

ASSEMBLY - SESTAVA

1

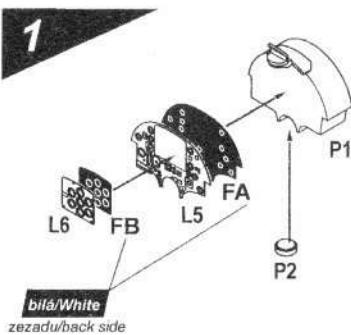

2

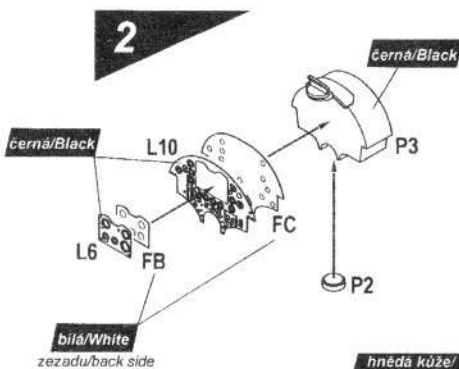

3

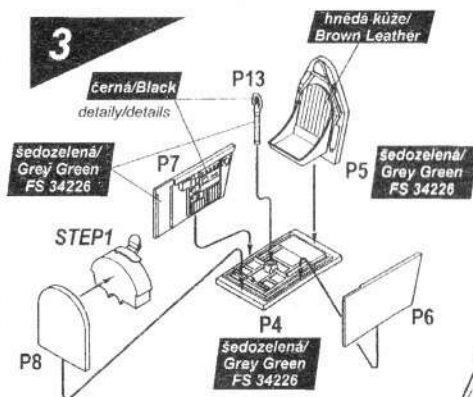

4

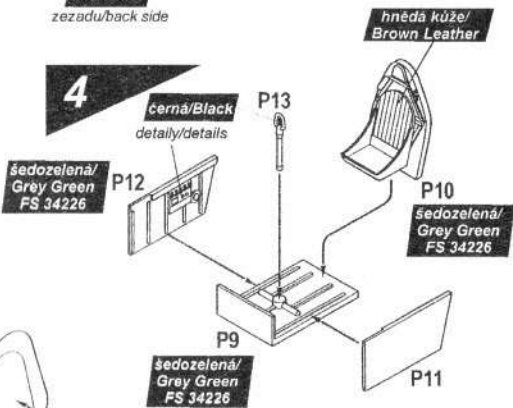

6

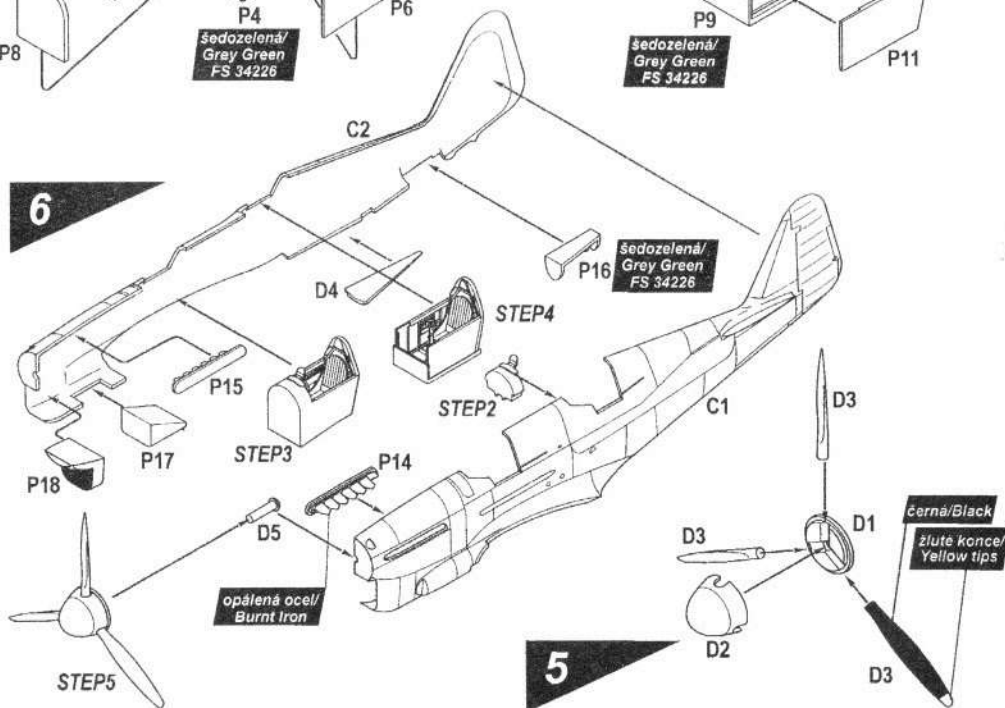

5

7

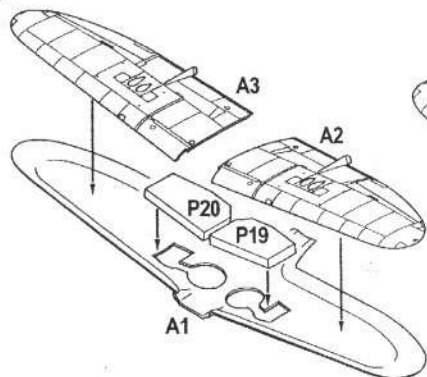

8

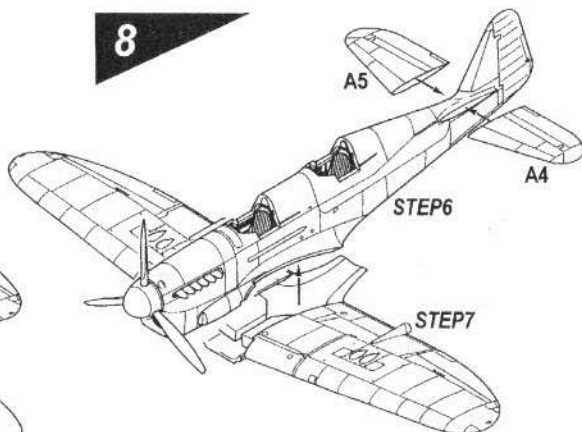

9

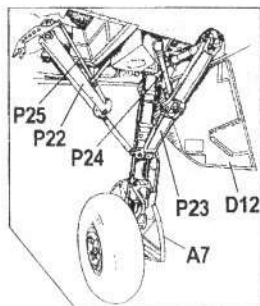
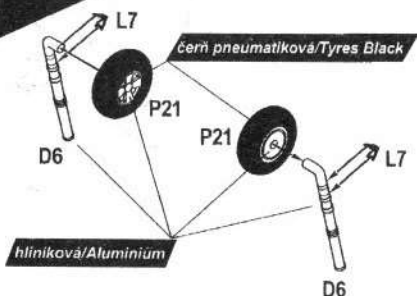

10

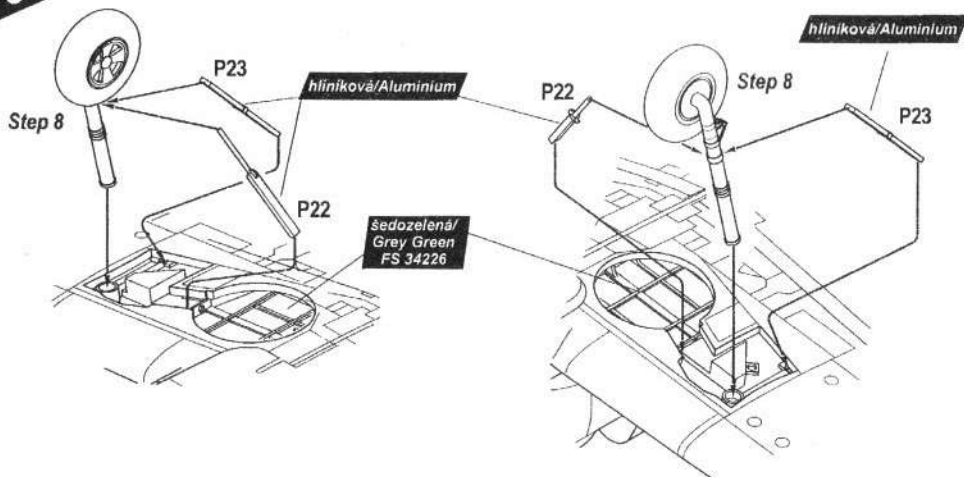

11

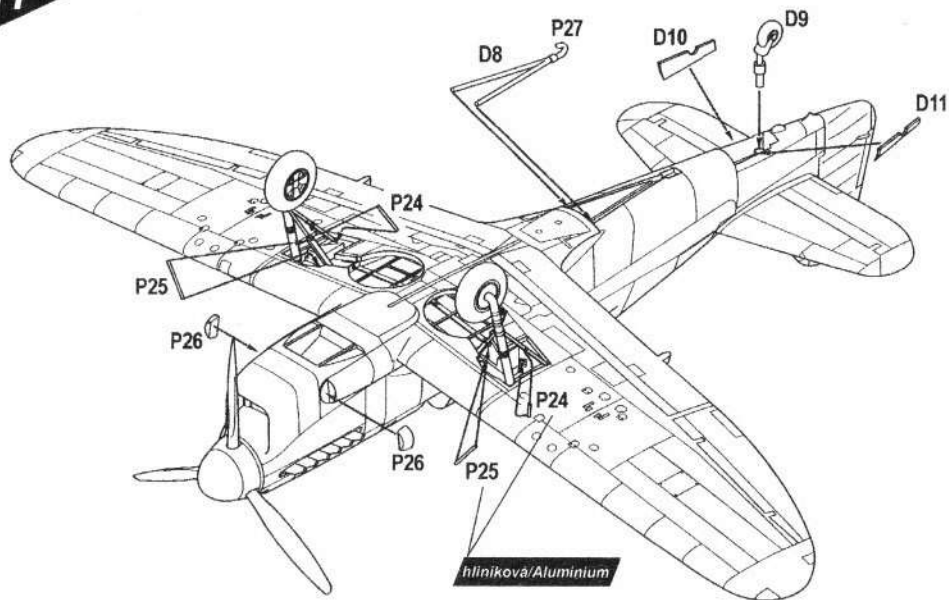

12

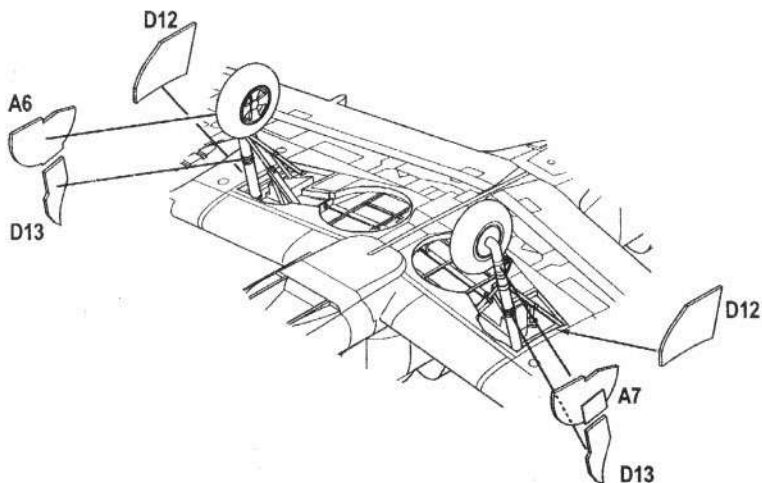

Photos and technical references:

Courtesy by: Chris Hughes, U.K.
Jon Yardley, U.K.

Technical research:

Courtesy by: Chris Hughes, U.K.
Erinc Ozgur, Turkey

Fairey Firefly

13

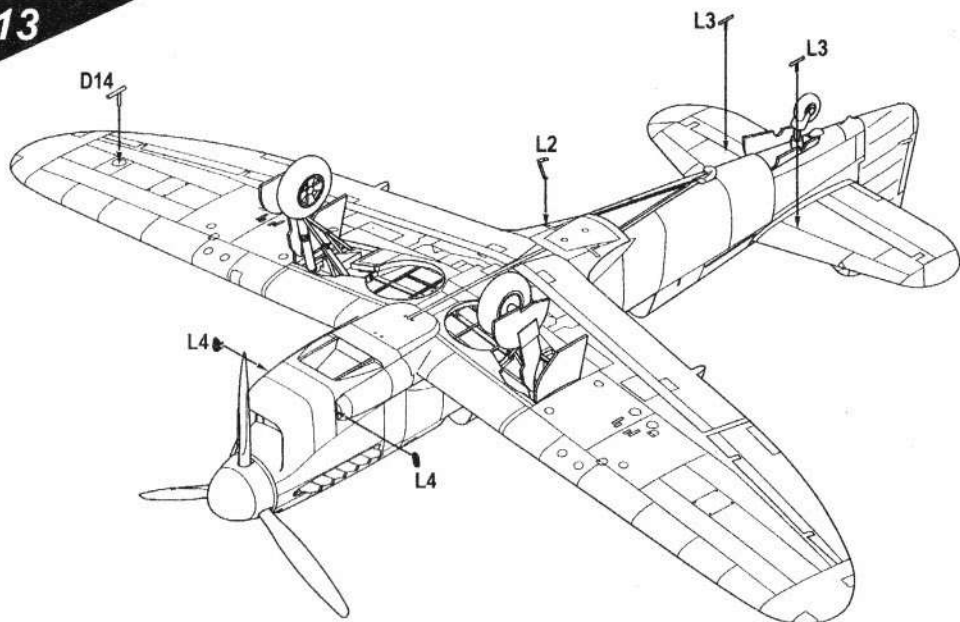

14

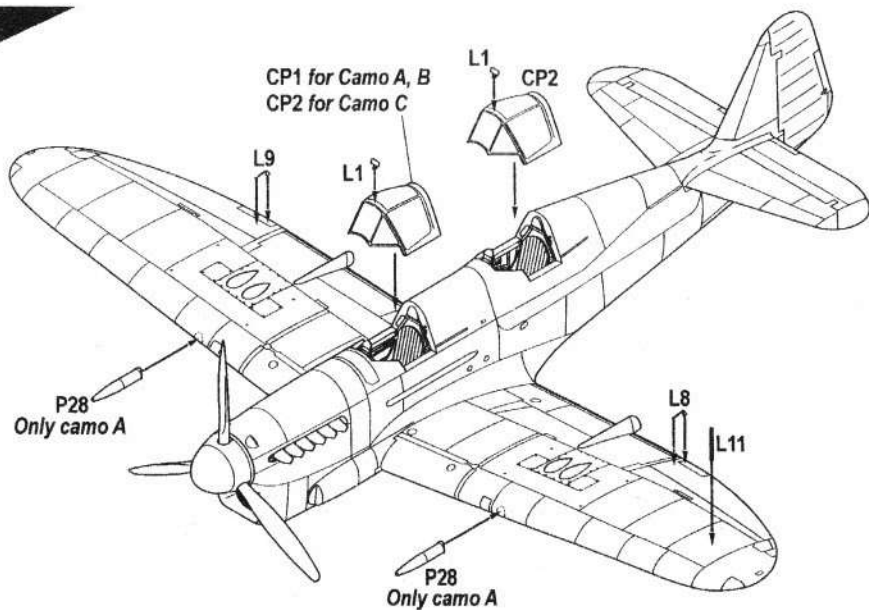

ZBARVENÍ a OZNAČOVÁNÍ

CAMOUFLAGE and MARKING, TARNUNG und KENNUNG, CAMOUFLAGE et DESIGNATION



Fairey Firefly T.2, MB578/906-GN, Station Flight, RNAS Eglinton, 1951.

Fairey Firefly T.2, MB578/906-GN, RNAS Eglinton Station Flight, 1951.

Cam. A

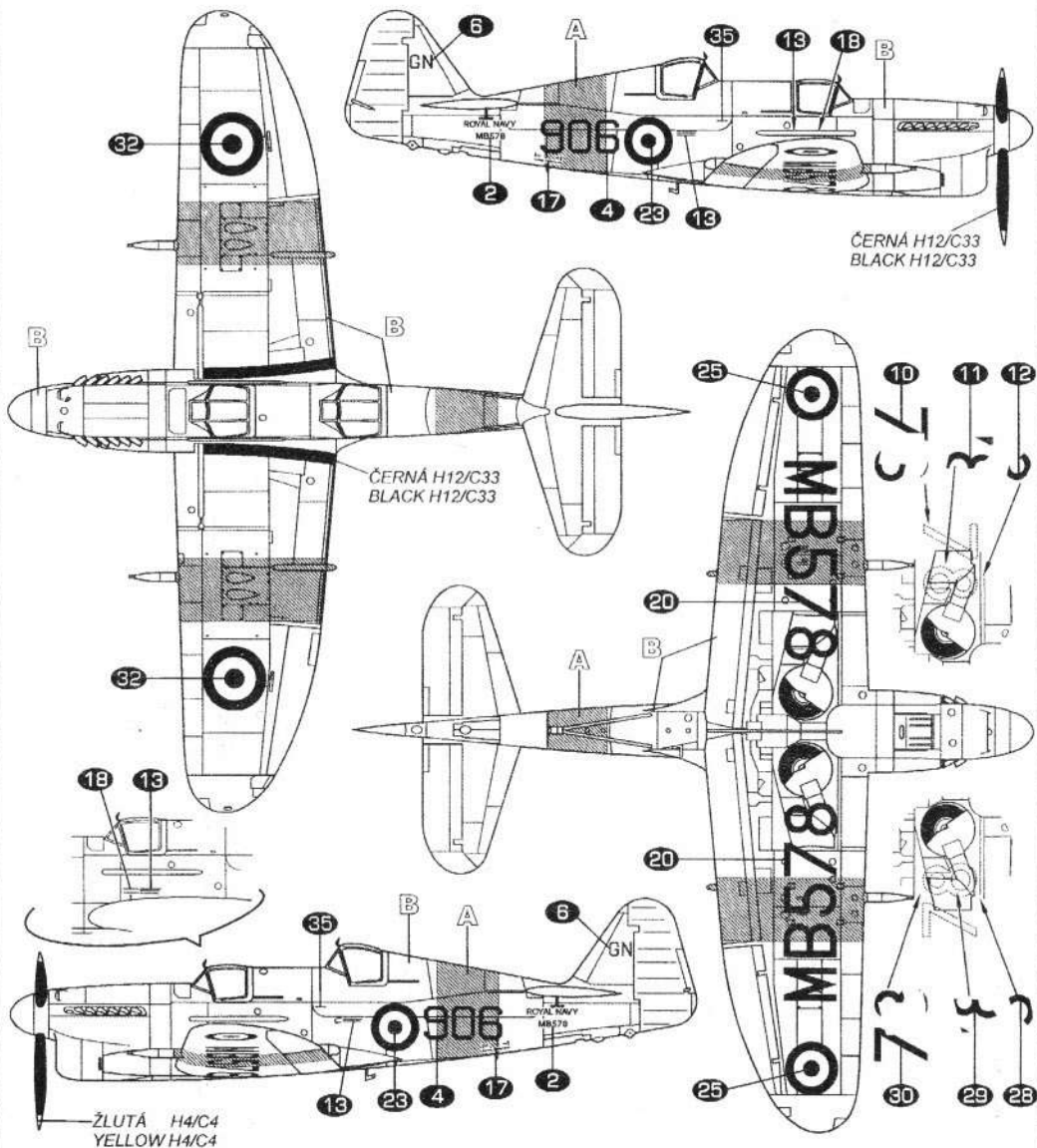

A
H4/C4
 Žlutá
 Yellow

B
H8/C8
 Stříbrná
 Silver

info
 Barvy GUNZE
 GUNZE colours No.

ZBARVENÍ a OZNAČOVÁNÍ

CAMOUFLAGE and MARKING TARNUNG und KENNUNG CAMOUFLAGE et DESIGNATION



Fairey Firefly T.1, Z2027, Royal Navy, 1948

Fairey Firefly T.1, Z2027, Royal Navy, 1948

Cam. B

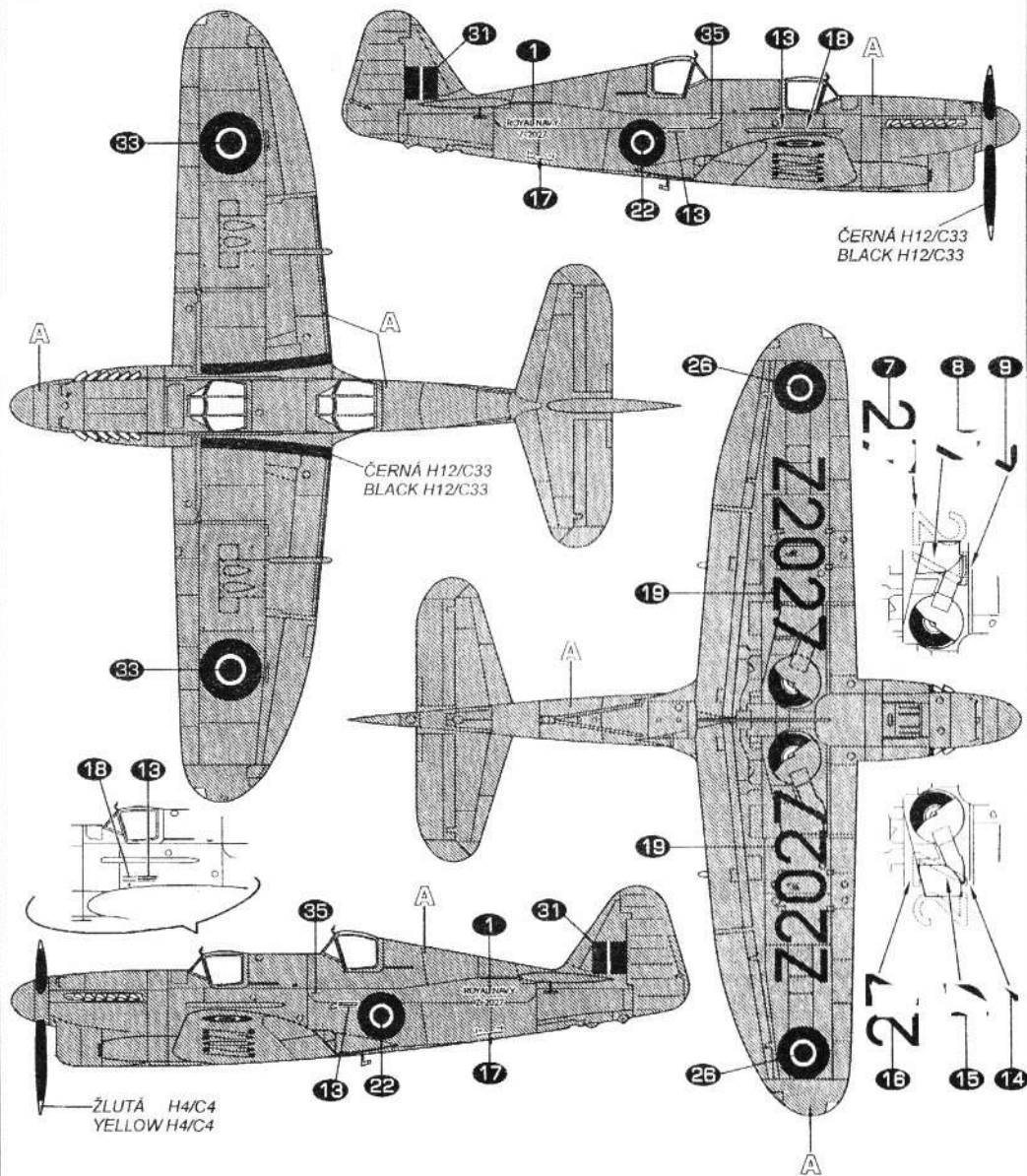

A
H4/C4 Žlutá
Yellow

info
Barvy GUNZE
GUNZE colours No.

ZBARVENÍ a OZNAČOVÁNÍ

CAMOUFLAGE and MARKING, TARNUNG und KENNUNG, CAMOUFLAGE et DESIGNATION



Fairey Firefly T.1, 12-H, Marine Luchtvaartdienst (Holandské námořní letectvo), 1949.
Fairey Firefly T.1, 12-H, Marine Luchtvaartdienst (Dutch Navy Air Force), 1949.

Cam. C

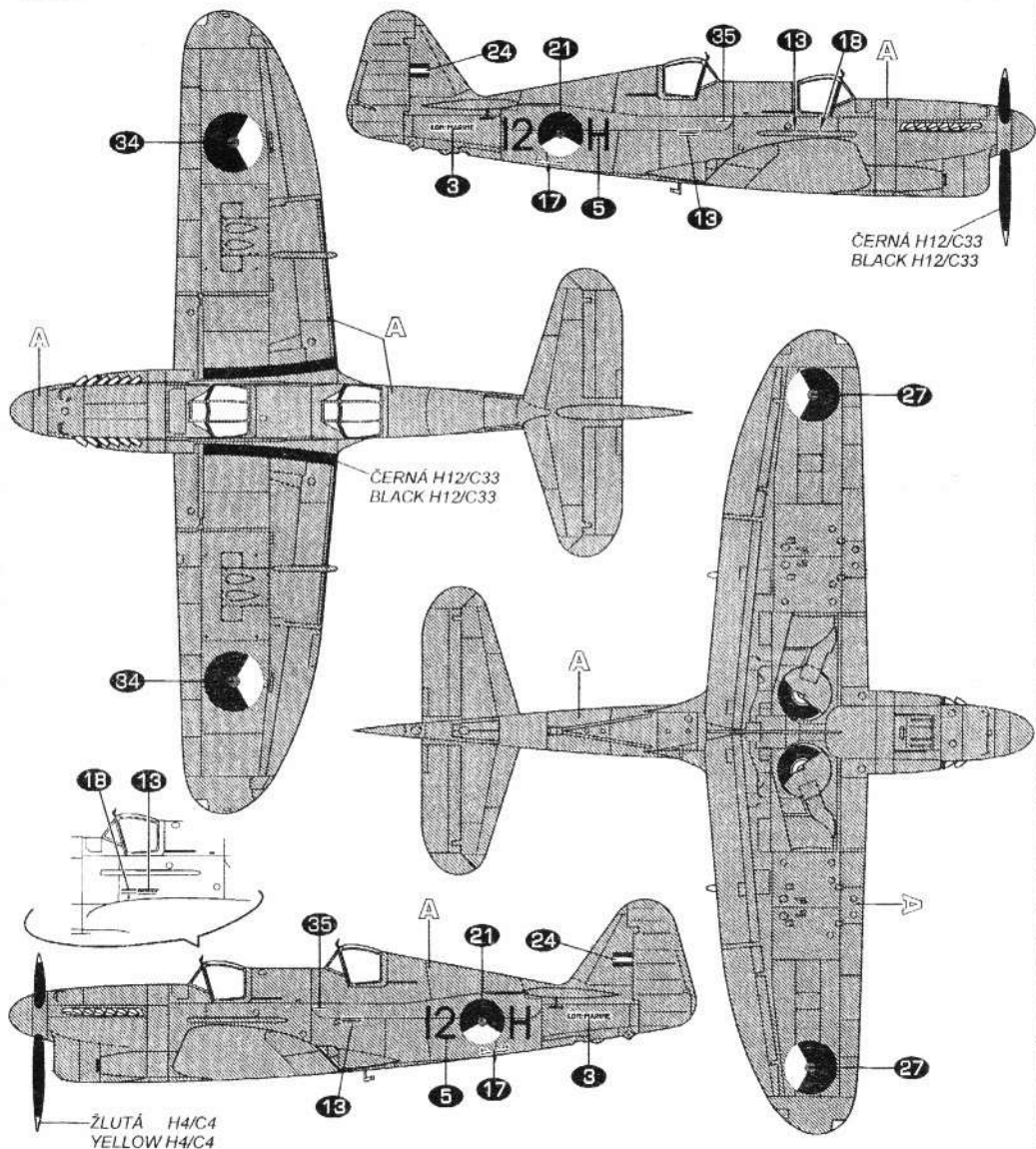

A
H4/C4
Žlutá
Yellow

Info
Barvy GUNZE
GUNZE colours No.

Special HOBBY limited run plastic kits

High quality injected plastic kits - short run/ Vstřikované modely - limitovaná série

FAA Aircraft from SPECIAL HOBBY

Plastic molding with PUR



and Photo - etched parts

1/72 scale

SH72030 Fairey Firefly Mk.I

Plastic molding with PUR



and Photo - etched parts

1/72 scale

SH72042 Vultee Vengeance TT. versions

Plastic molding with PUR

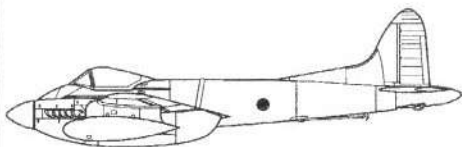

and Photo - etched parts

1/72 scale

SH72057 D.H. 103 Sea Hornet F. Mk.20/PR.22

Plastic molding with PUR

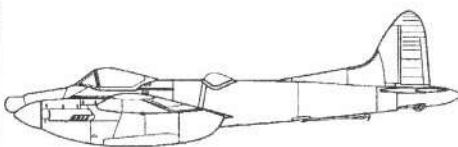

and Photo - etched parts

1/72 scale

SH72059 D.H. 103 Sea Hornet NF. Mk.21

Plastic molding with PUR

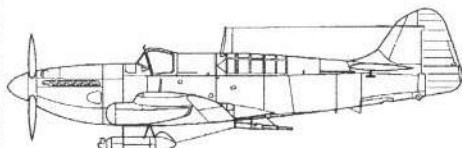

and Photo - etched parts

1/72 scale

SH72066 Fairey Firefly TT. Mk.IV

Plastic molding with PUR

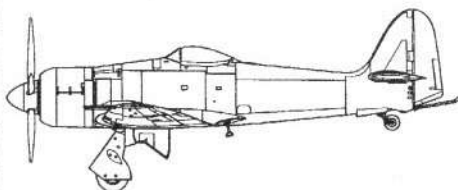

1/72 scale

SH72073 Hawker Sea Fury FB. Mk.11

oficiální stránky MPM Production / MPM Production official website

oficiální stránky CMK / CMK official website

www.mpmkits.com

www.cmkkits.com

ROYAL NAVY ① ROYAL NAVY
Z 2027 Z 2027

ROYAL NAVY ② ROYAL NAVY
MB578 MB578

KON. MARINE ③

906 ④

906

H ⑤ H

12 H 12 H

GN ⑥ GN

2 2 3 7 3

9 9

13

BAND POSITION 17 BAND POSITION

18

19

Z2027

Z2027

MB578

MB578



③ KON. MARINE

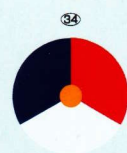

SH 72050

1/72



4



10

11



3



1

8



9



6



2

7



Fairey Firefly T.1/ T.2

Made in Czech Republic

