

2in1

BÜCKER 133 A/B 1/7 SCAI

The Bücker Bü 133 Jungmeister was an advanced trainer of the Luftwaffe in the 1930s. It was a single-engine, single-seat biplane of wood and tubular steel construction and covered in fabric. The Bü 133 was a development of the Bücker Bü 131 Jungmann two seat basic trainer. First flown in 1935 (by Luise Hoffmann, the first female works pilot in Germany), it was slightly smaller than the E 131. The prototype, D-EVEO, was powered by a 140 hp (104 kW Hirth HM506 inverted, air-cooled inline-6 engine. The aircraft showed "astonishing agility" at its first public appearance, the 1936 International Aerobatic Championship at Rangsdorf, but th Bü 133A garnered no orders; only two Bü 133Bs, with 160hp (11 kW) version of that same Hirth HM506 inline-6 engine, were built

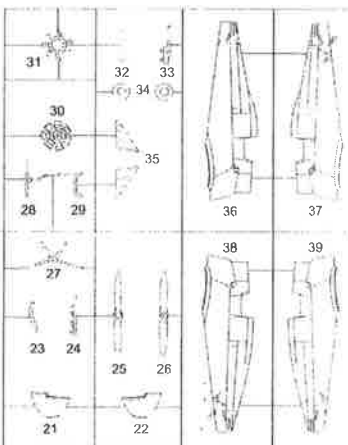
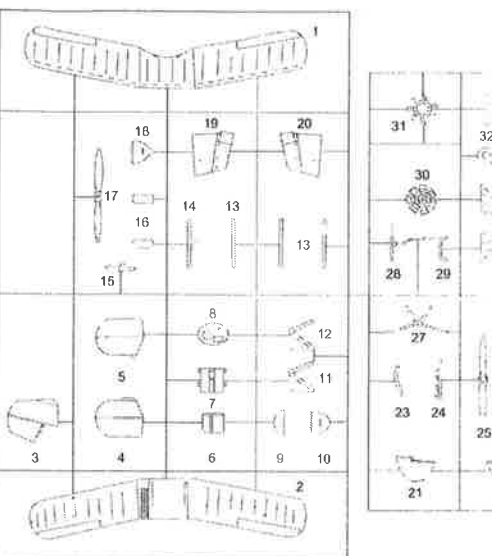
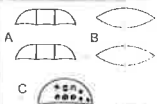

PHOTO-ETCHED PARTS (PE)



POLYURETHAN PARTS (PUR)



RESIN PARTS (RI)

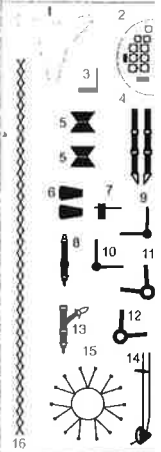

COLORS

- A** Černá Black
- B** Stříbrná Silver
- C** Kůže Leather
- D** Plátno Linen
- E** RLM 02
- F** Pneu Tyres

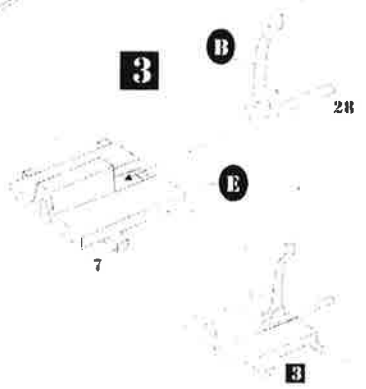
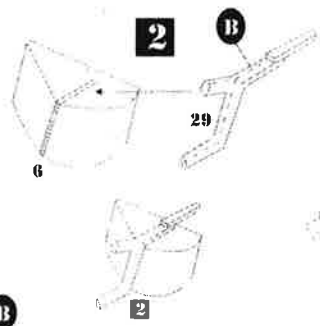
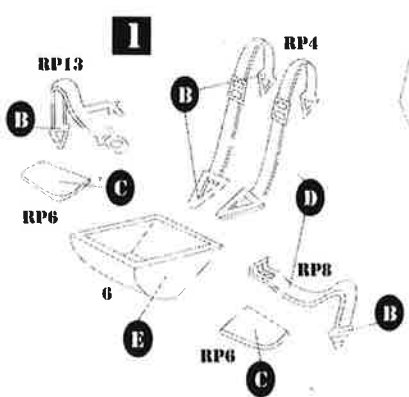

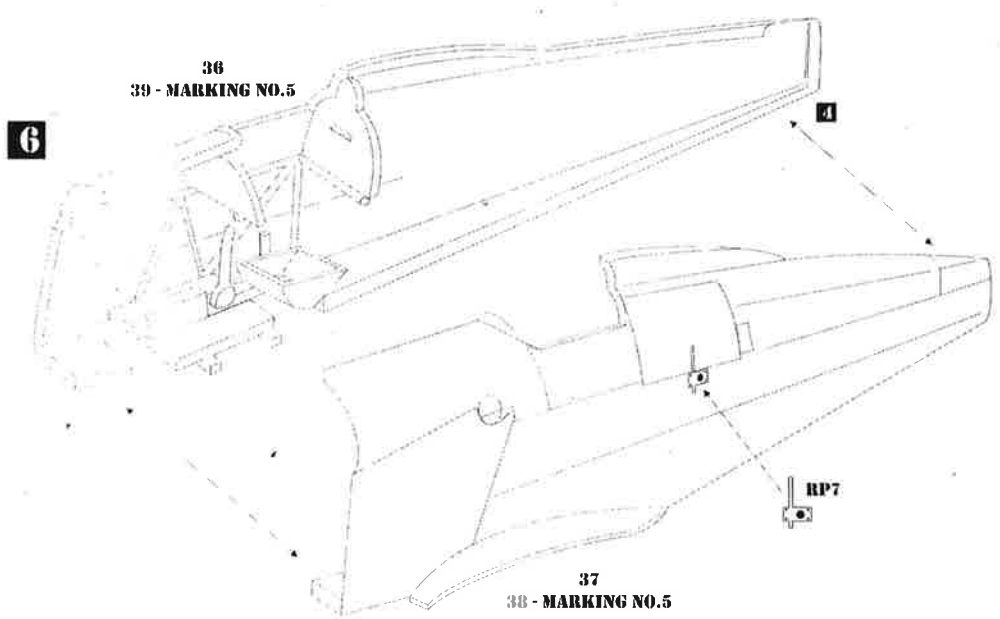
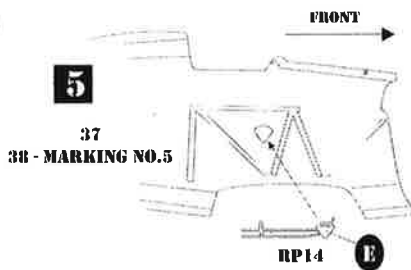
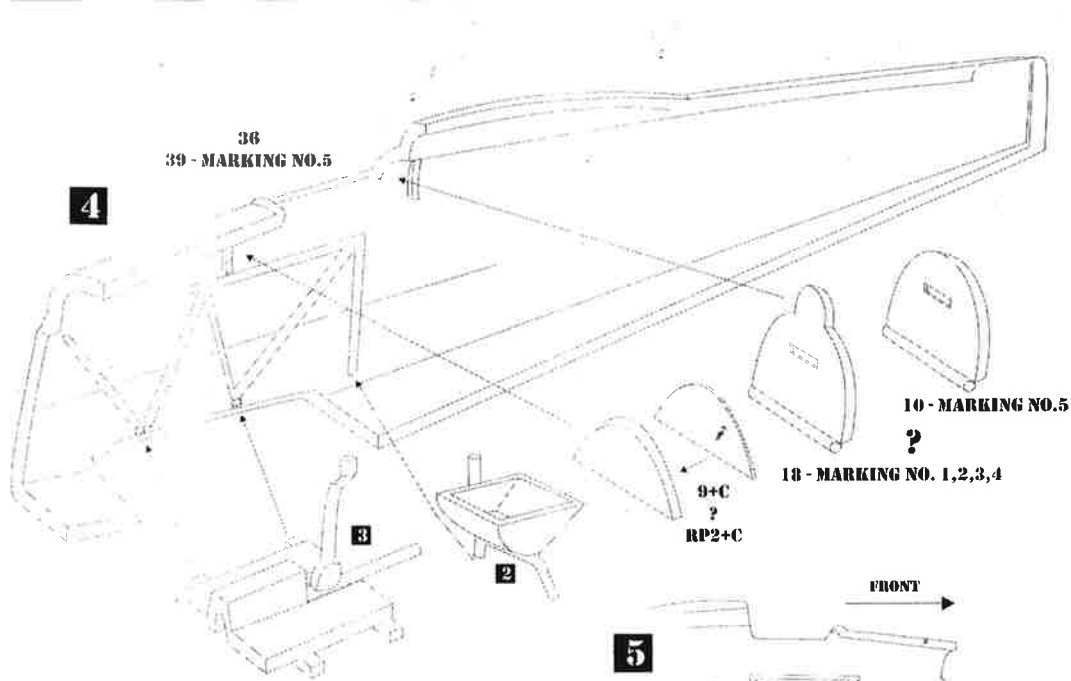

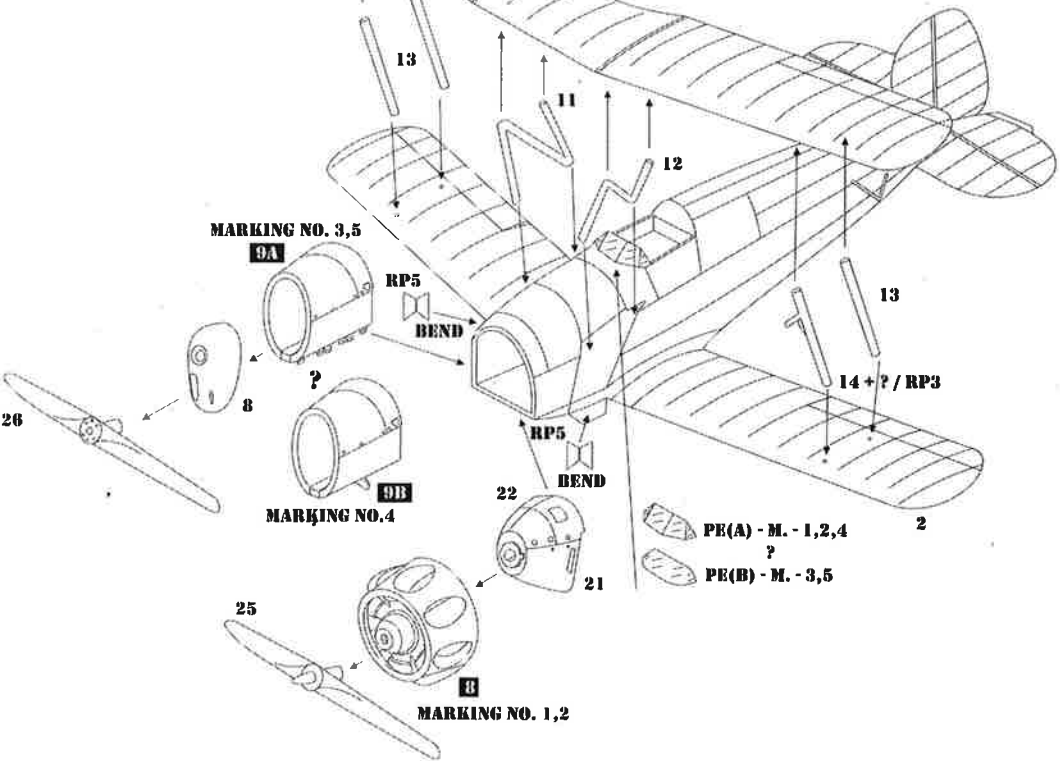
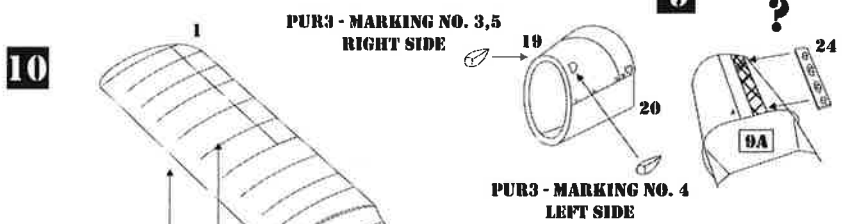
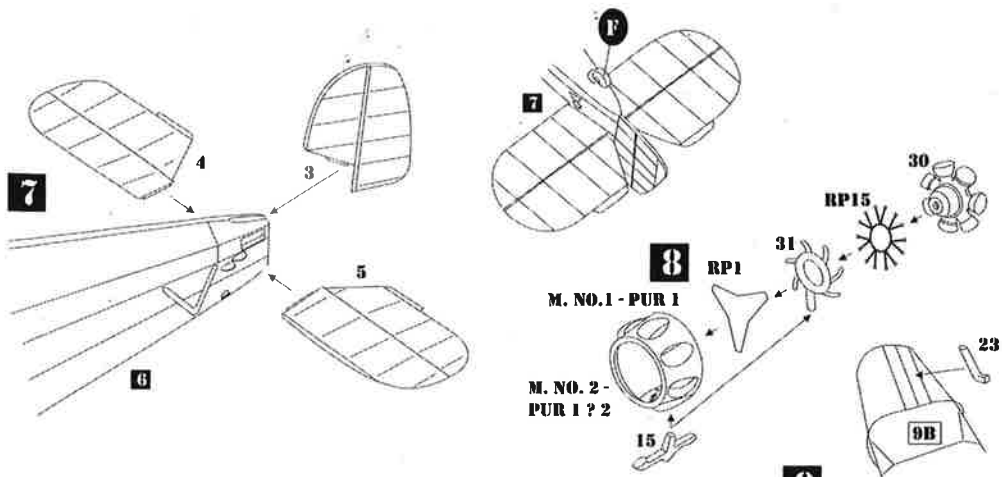

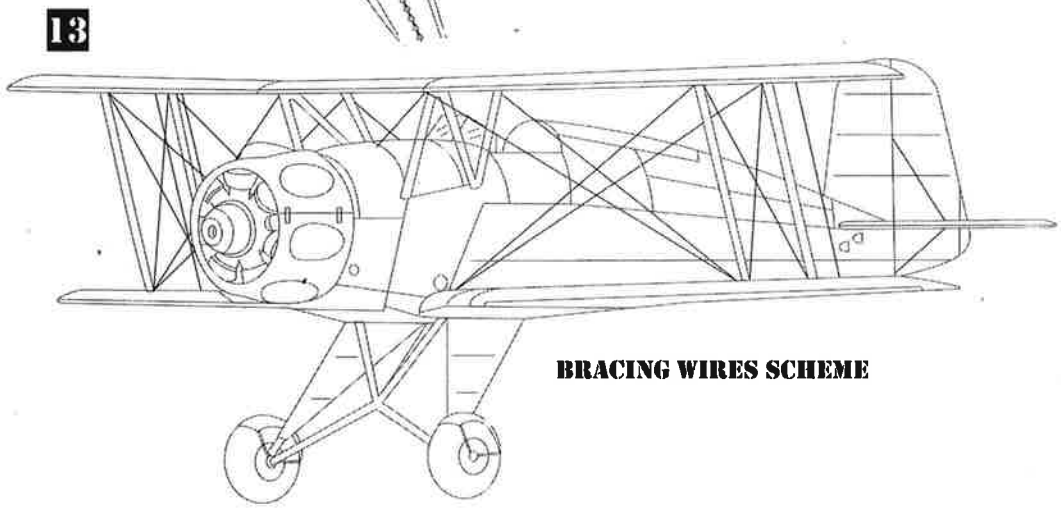
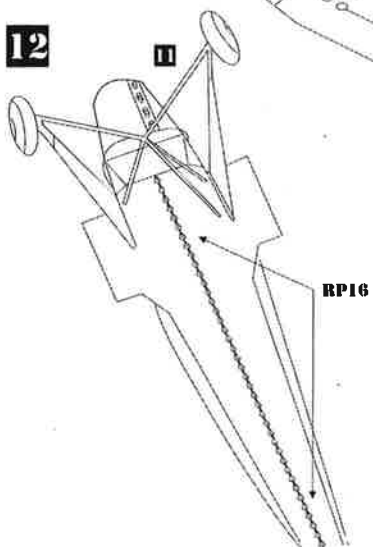
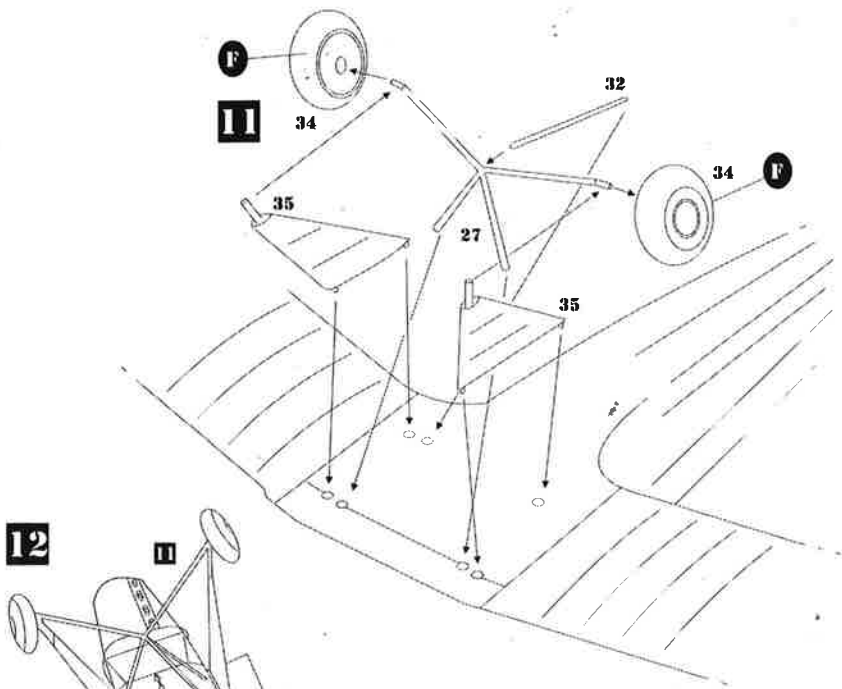

BRACING WIRES SCHEME