

Clear Prop!

ADVANCED



LA-5

EARLY VERSION

1:72
model # CP72014



scale model kit

SPAN: 136 mm



LENGTH: 121 mm



NUMBER OF PARTS: 136 pcs

- 1** stages of assembly
- A** variants of assembly
- A1** part number
- 1** separate details
- 1** apply decals
- 1** apply the adhesive mask
- 1** bend
- ?** optional
- glue by super glue
- do not glue
- make a hole
- detach with knife
- paint
- repeat the operation N times

Lavochkin La-5
Role
Manufacturer
First flight
Primary user
Number built

Fighter aircraft
Lavochkin
March 1942
Soviet Air Force
9 920

The Lavochkin La-5 was a Soviet fighter aircraft of World War II. It was a development and refinement of the LaGG-3, replacing the earlier model's inline engine with the much more powerful Shvetsov ASh-82 radial engine. During its time in service, it was one of the Soviet Air Force's most capable types of warplane, able to fight German designs on an equal footing.

The La-5's heritage began even before the outbreak of war, with the LaGG-1, a promising yet under-powered aircraft. The LaGG-3 was a modification of that design that attempted to correct this by both lightening the airframe and fitting a more powerful engine. Nevertheless, this was not enough, and the lack of power remained a significant problem.

When the prototype took flight in March, the result was surprisingly pleasing – the fighter finally had a powerplant that allowed it to perform as well in the air as it had been supposed to on paper. After flying, the LaG-5 (the change in name reflecting that one of the original LaGG designers, Mikhail I. Gudkov, was no longer with the programme), Air Force test pilots declared it superior to the Yak-7, and intensive flight tests began in April. Further refinement of the aircraft involved cutting down the rear fuselage to give the pilot better visibility, making this version the La-5F. Later, a fuel-injected engine, a different engine air intake and further lightening of the aircraft led to the designation La-5FN that would become the definitive version of the aircraft.

REQUIRED PAINTS



A. MIG-0080
AMT-4 GREEN



B. MIG-0046
AMT-6 BLACK



C. MIG-0251
AMT-7 LIGHT BLUE



D. MIG-0046
BLACK



E. MIG-0194
ALUMINIUM



F. MIG-0191
POLISHED STEEL



G. MIG-0195
SILVER



H. MIG-0033
TIRE BLACK



I. MIG-0202
DECK TAN



J. MIG-0187
PALE BURNT METAL



K. MIG-0125
ORANGE YELLOW



L. MIG-0049
INSIGNIA RED



M. MIG-0205
STEEL GRAY



AMMO
by MIG Jimenez

THIS MODEL IS PRODUCED FOR EXPERIENCED MODELERS OVER 14 YEARS

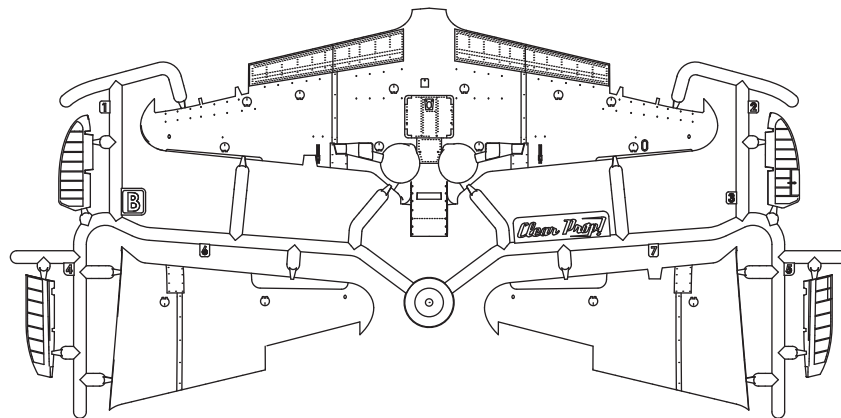
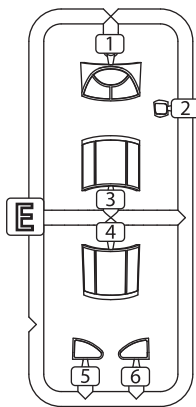
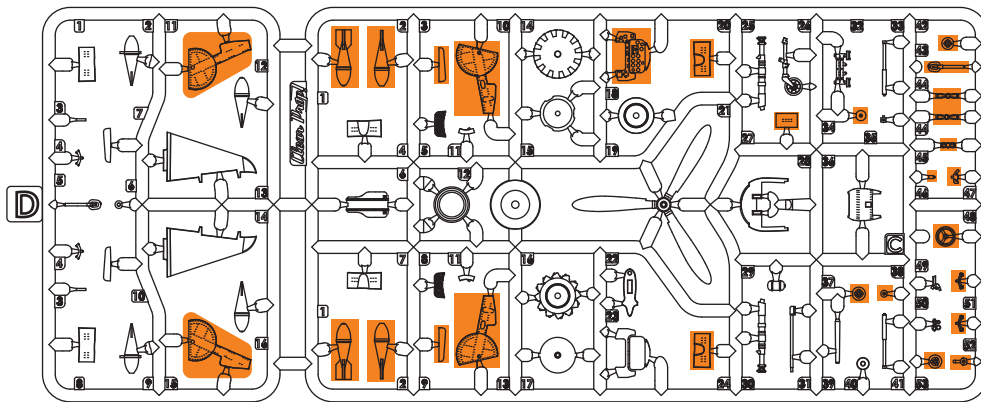
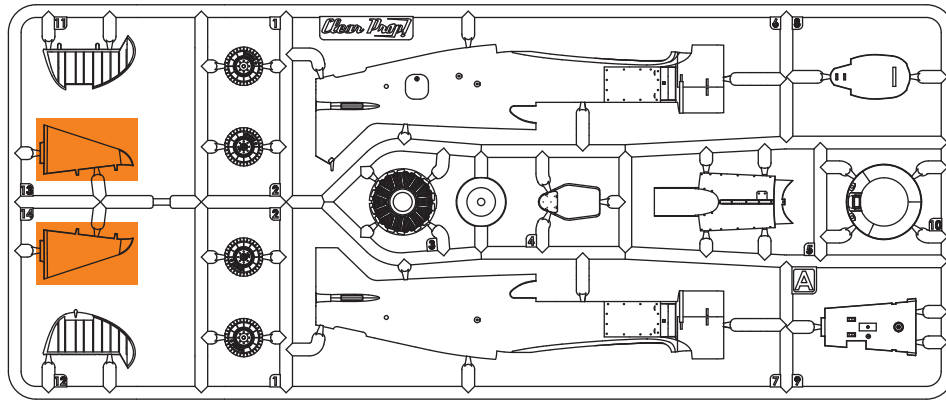

PHOTOETCHED PARTS

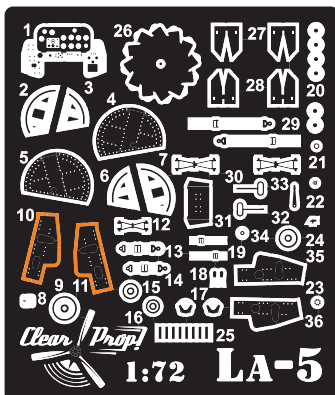

DECAL SHEET

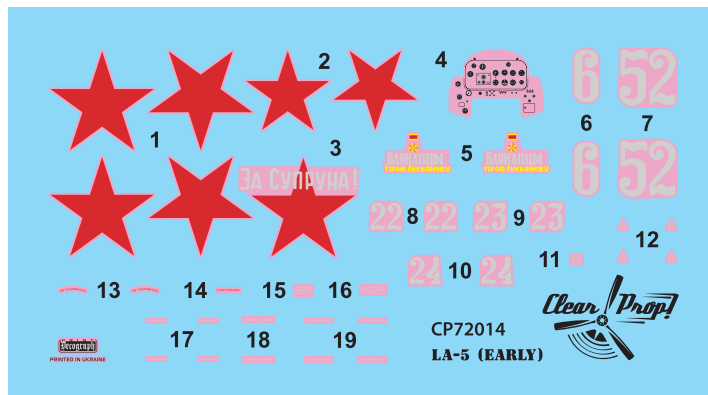

Parts not for use

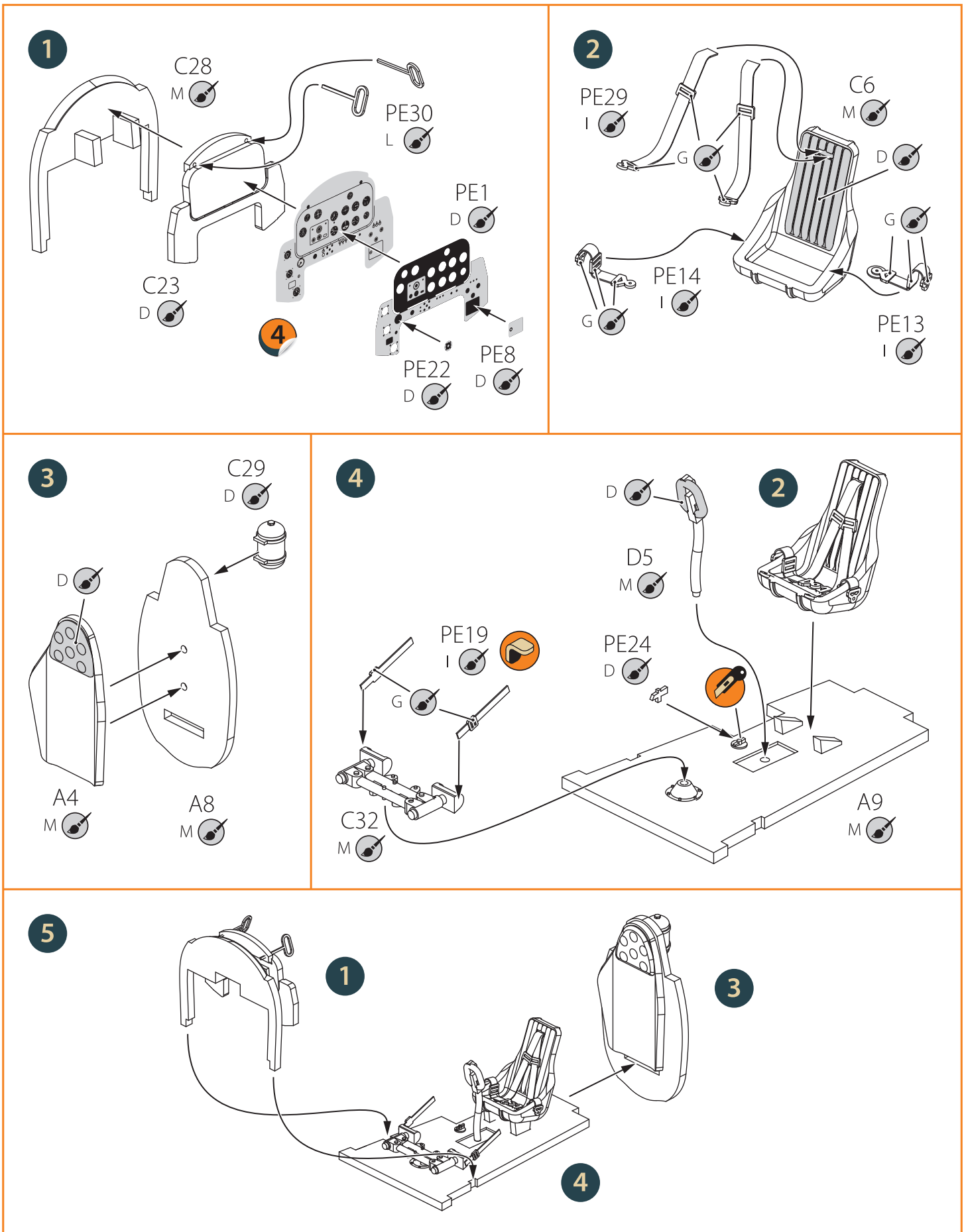

6

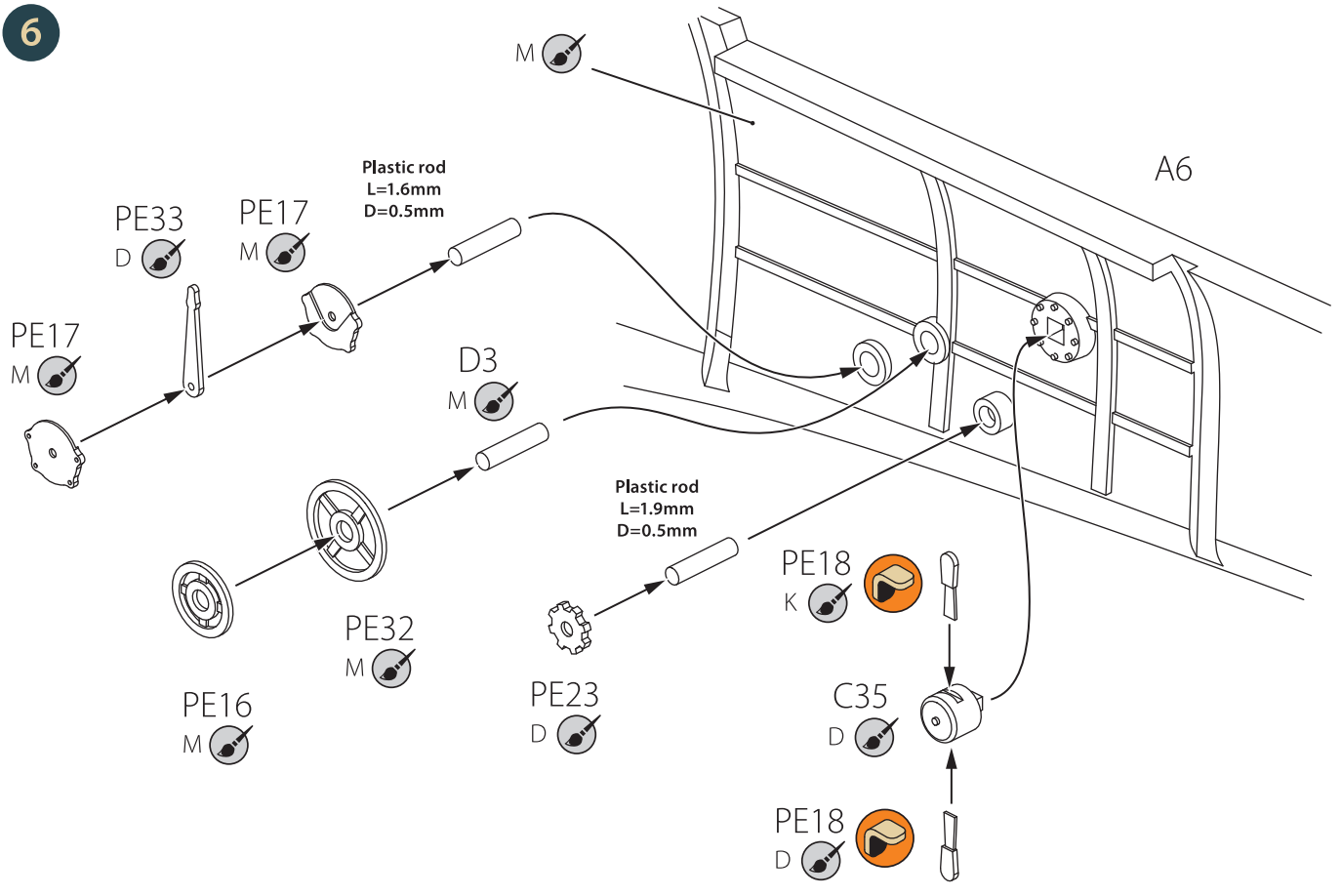

7

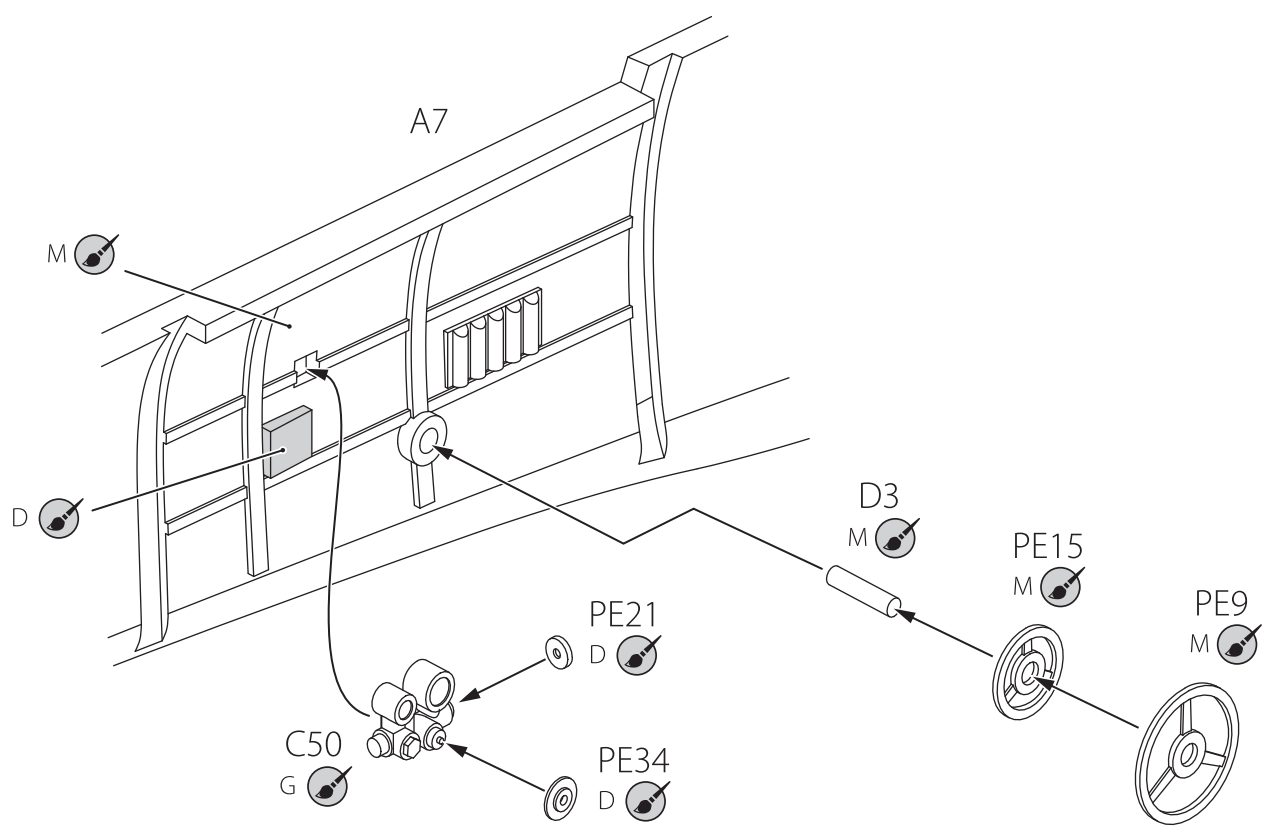

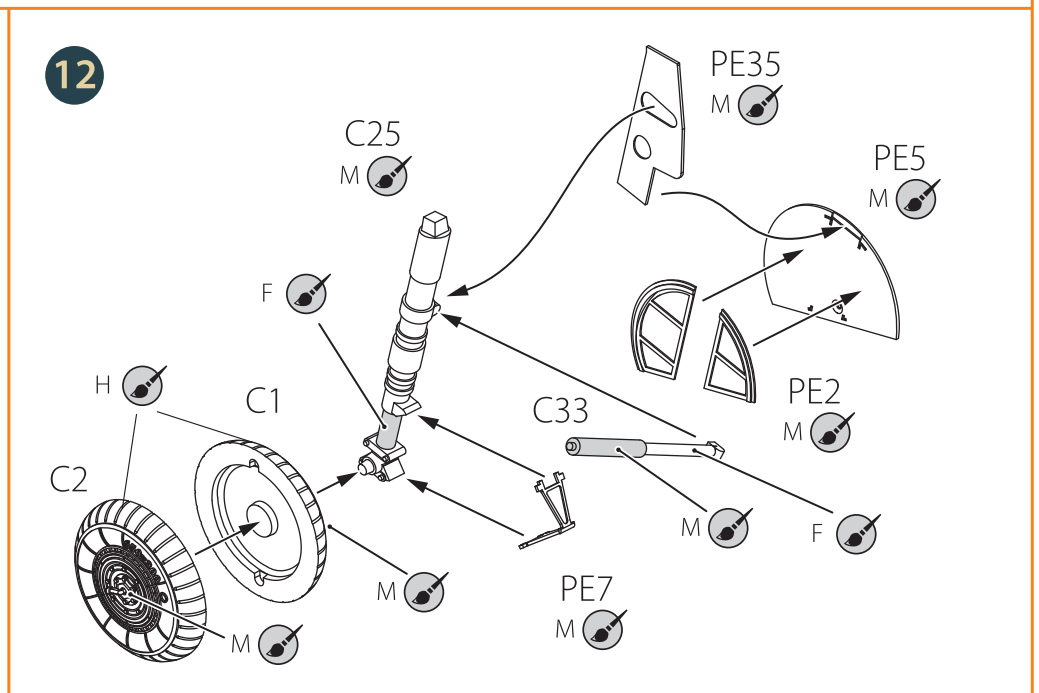
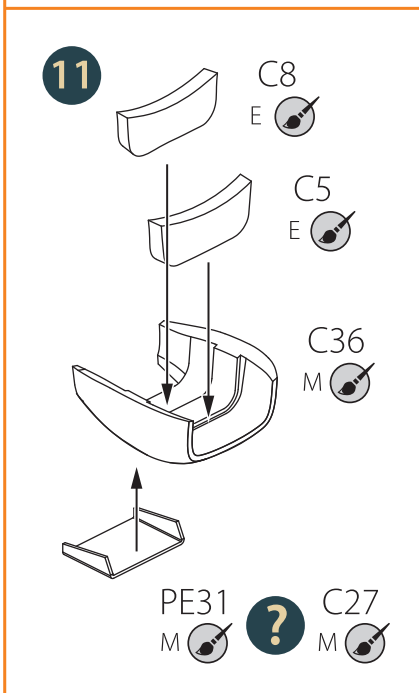
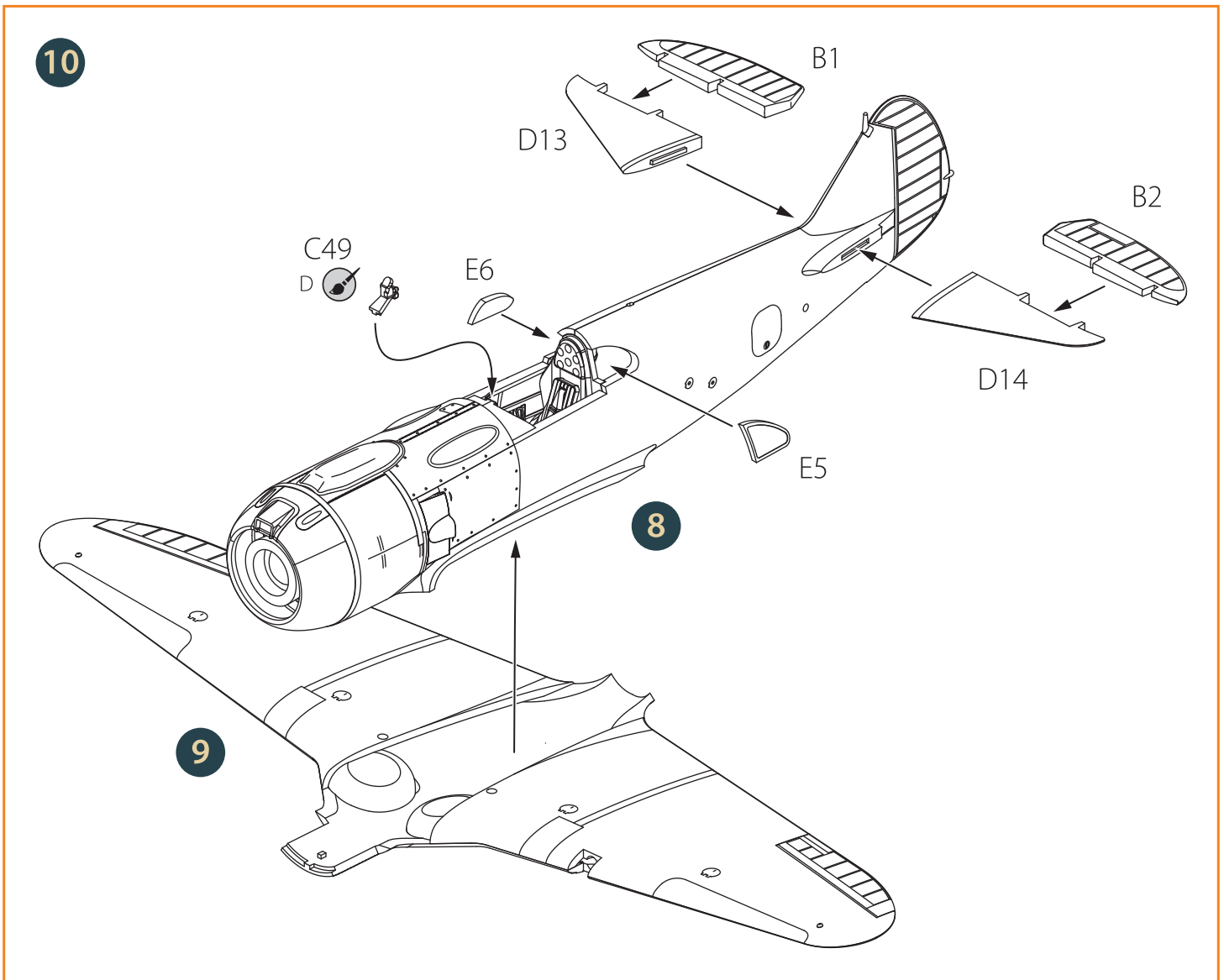

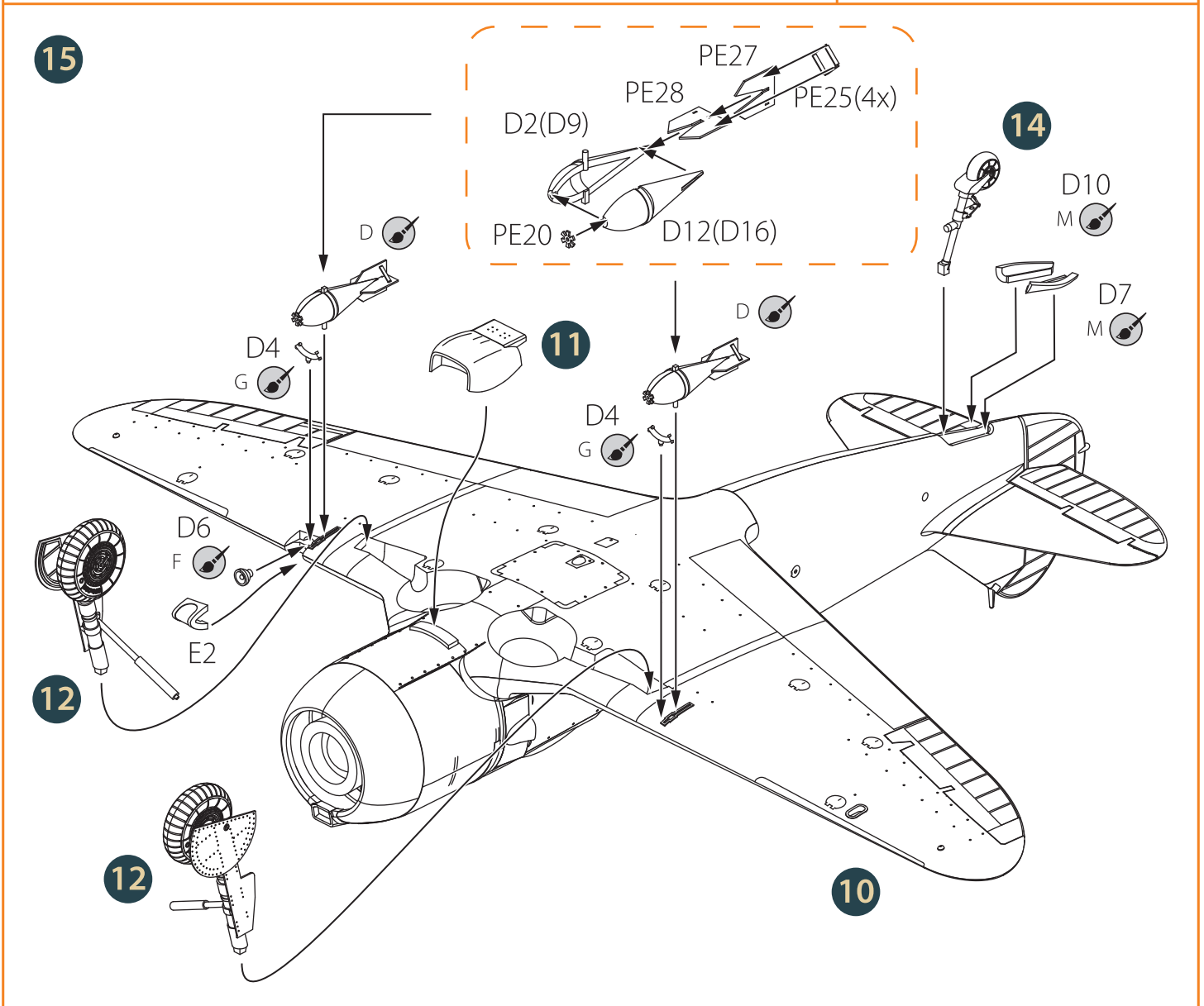
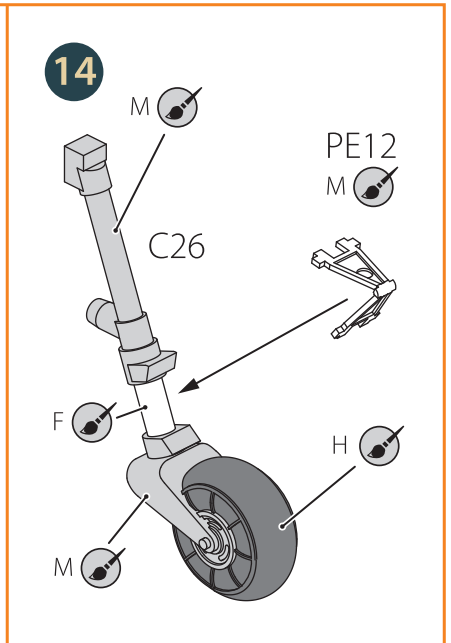
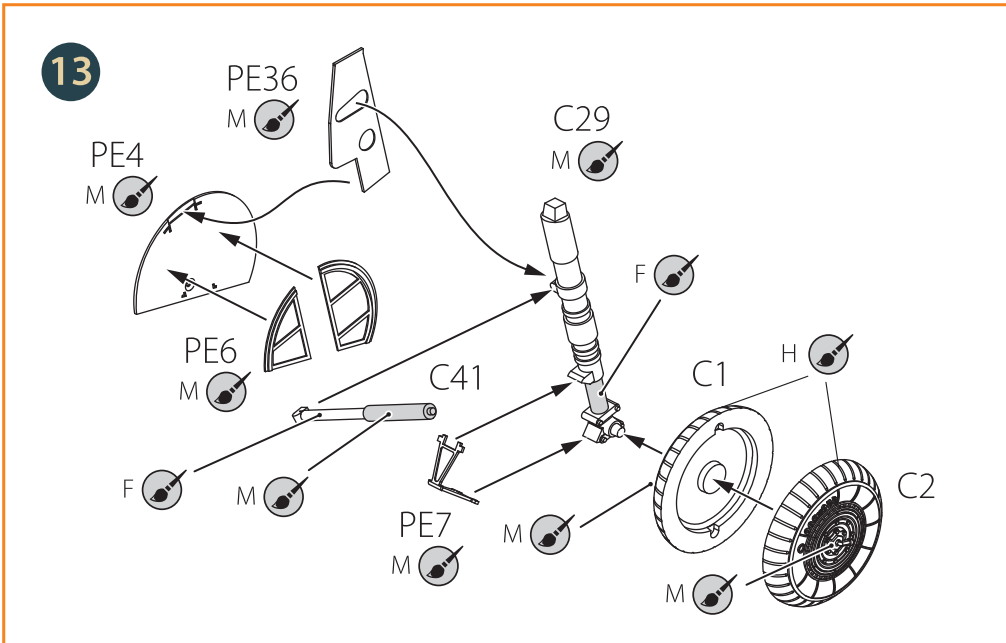

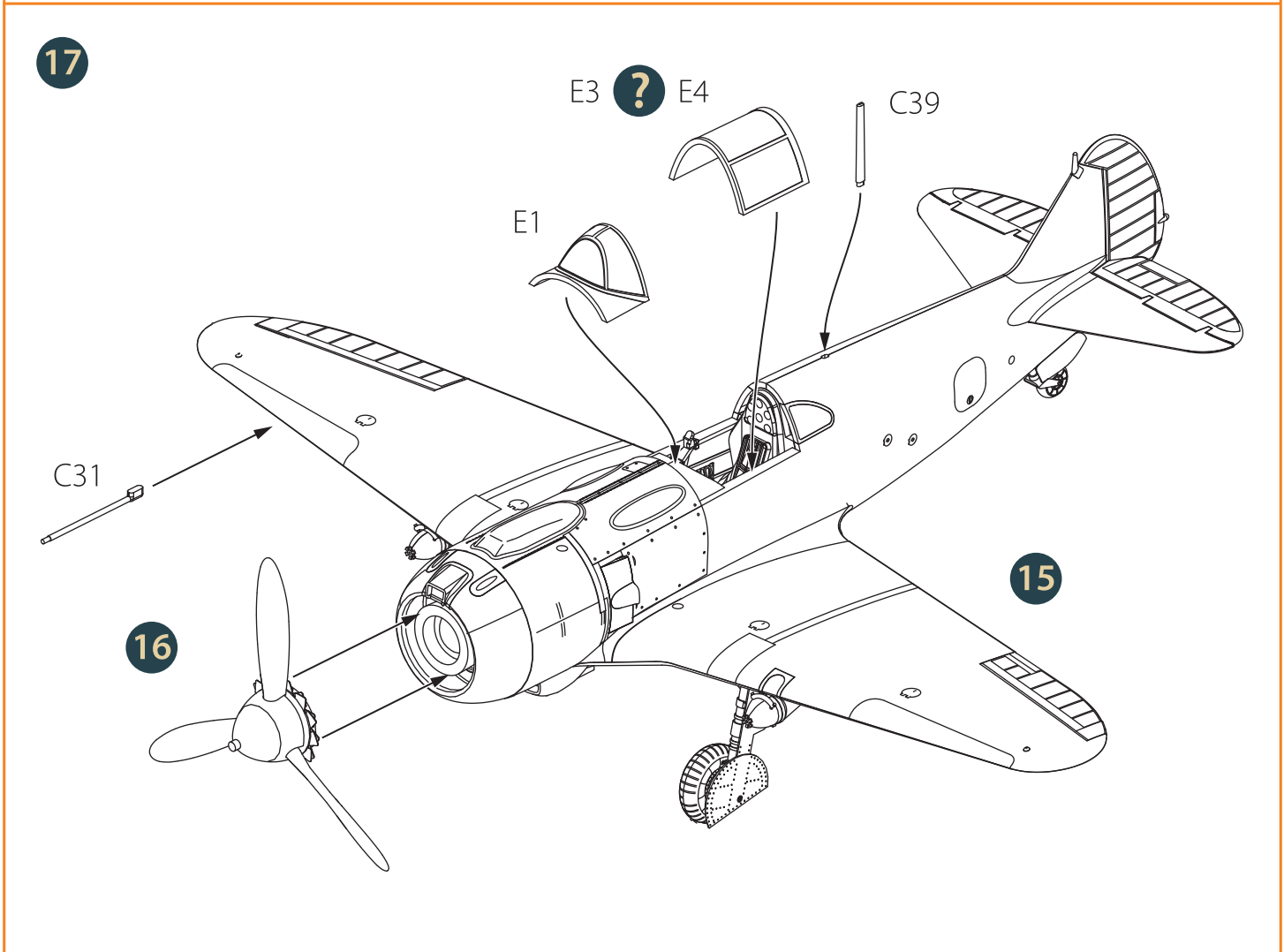
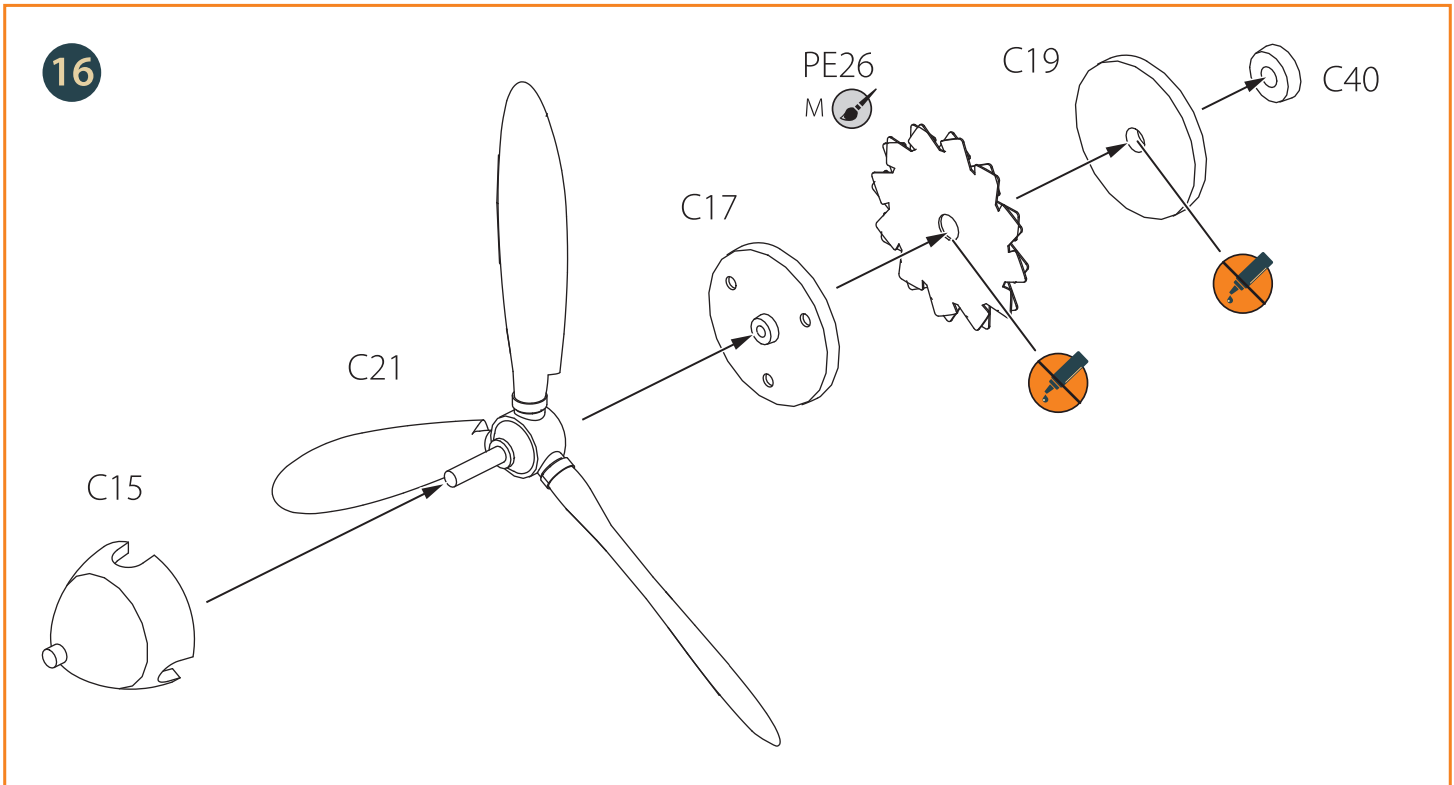



A A.MIG-0080
AMT-4 GREEN



B A.MIG-0046
AMT-6 BLACK



C A.MIG-0251
AMT-7 LIGHT
BLUE



D A.MIG-0046
BLACK



E A.MIG-0194
ALUMINIUM



F A.MIG-0191
POLISHED
STEEL

① La-5 of 240 fighter regiment, 287 fighter division, Stalingrad area, August 1942

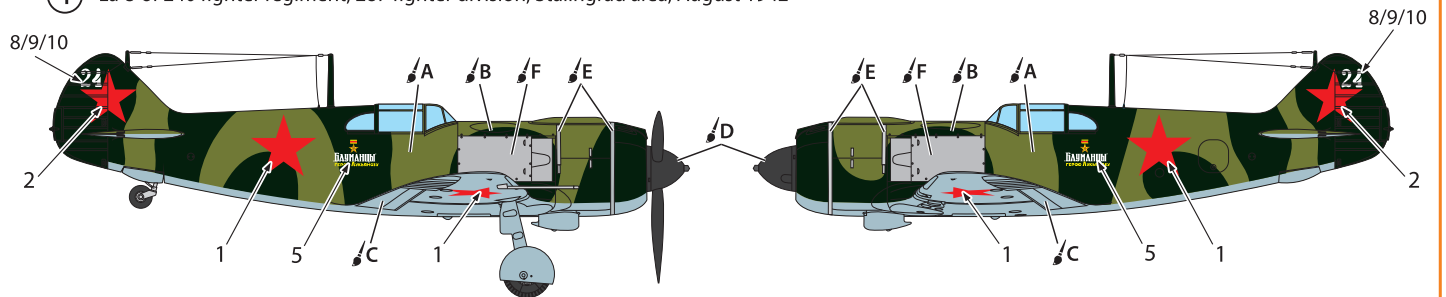

② La-5 of 263 fighter regiment, 215 fighter division, Leningrad area, autumn 1942

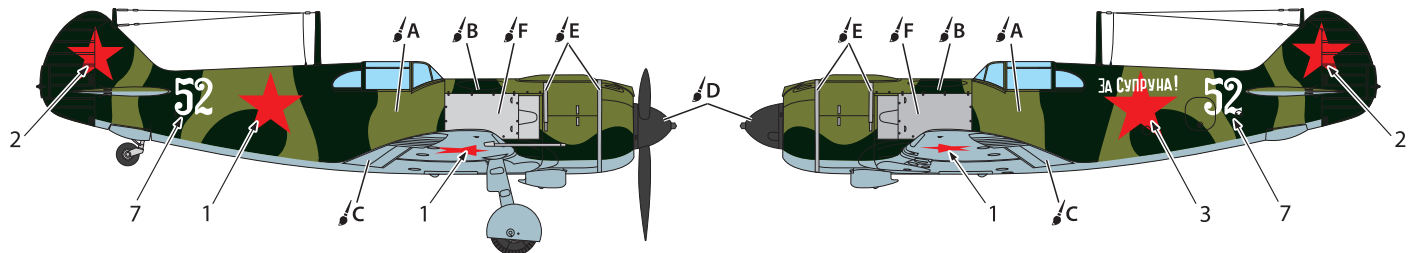

③ La-5 of an unknown unit, autumn 1942

