

BI BRANIFF INTERNATIONAL

BOEING 707 IN 1/144 SCALE



"The end of the plain plane", the colorful brochure announced. Here was literally a rainbow of colors decorating their fleet of new jetliners. The fuselage of each plane was painted an eye-catching shade of blue, turquoise, green, lemon, orange or beige. The rest of the plane was white and natural metal. This was the introduction of Braniff International Airlines' new image in 1965.

Most airlines used the same generic scheme on every airplane, but with the arrival of the new Braniff scheme, the airport loading ramps took on the appearance of a painter's pallet. Even the crew and flight attendants received new attire, designed by Pucci.

According to the brochure, the hostess boards the plane wearing a "reversible cold weather coat, matching gloves and boots, a velveteen scarf and hat". She removes these and greets the passengers in a raspberry-colored suit with color

coordinated shoes! When dinner is served, the hostess is found wearing a serving dress, which is exchanged for a high-necked blouse and culottes in blue following the meal.

Even the ground service crew was provided with Pucci uniforms and the baggage carts, loading ramps and service vehicles wore a coat of the colorful paint.

Braniff began in 1928, when Paul Braniff began three flights a day between Tulsa and Oklahoma City. About a year later, the company was purchased by Universal Aviation. But Braniff knew there was market in supplying rapid service to the men developing new oil fields, so he purchased a pair of Lockheed Vegas and formed Braniff Airways. In 1934, the company received a contract to fly air mail, and the future of the small airline was established.

-  Cement
Coller
Kleben
Pegar
Incollare
Color
Kleven
-  DO NOT Cement
Ne pas Coller
Nicht Kleben
No Pegar
Non Incollare
Nae Color
Nae Kleven
-  Cut away
Couper
Schneiden
Corta
Tagliere
Cortar
Snijden
-  Optional parts
Choix
Auswahlmoglichkeit
Eleccion
Scelta
Opazo
Keuze

1 FUSELAGE ASSEMBLY

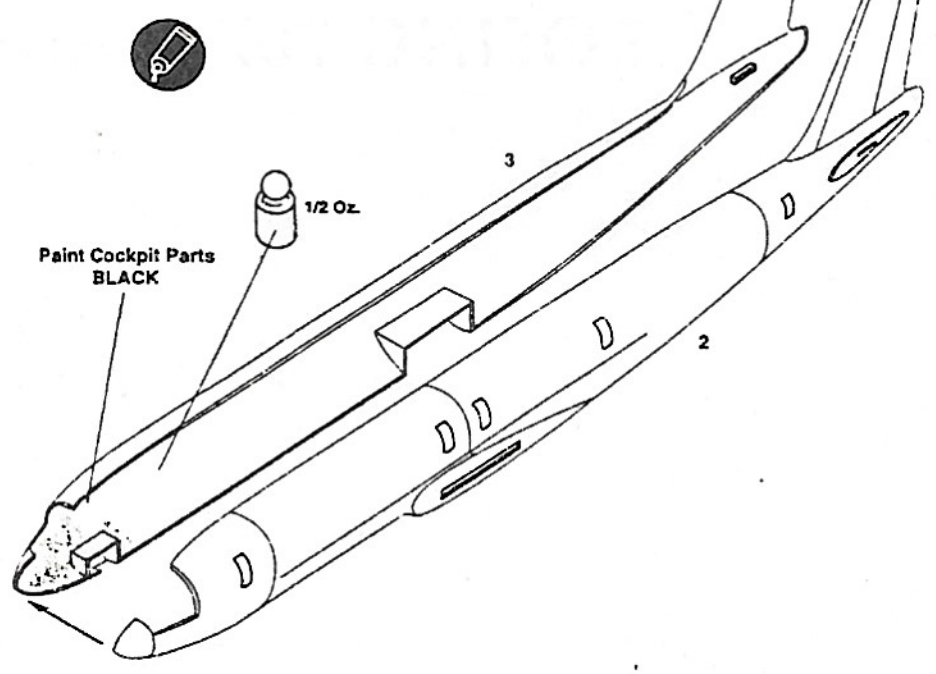

2 WING ASSEMBLY

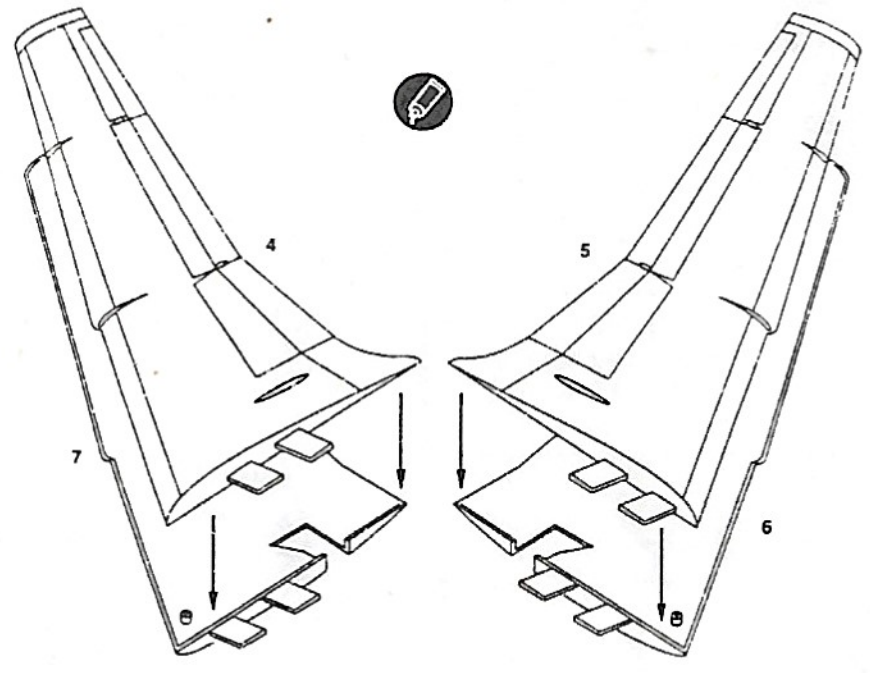

3

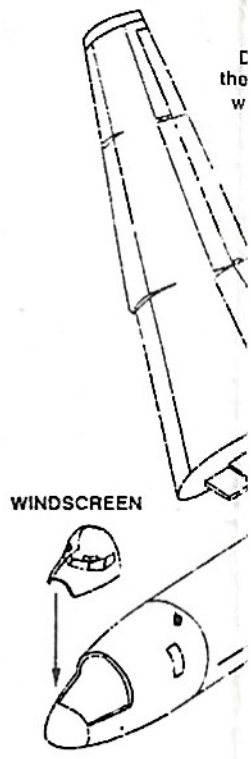

5 MAIN LANDING GEAR WELL

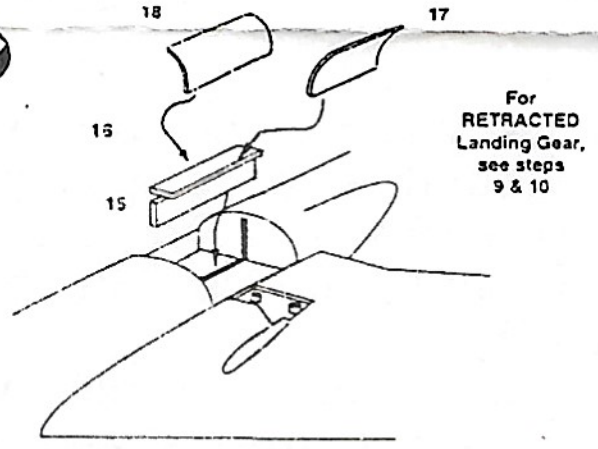

6 LEFT MAIN LANDING GEAR

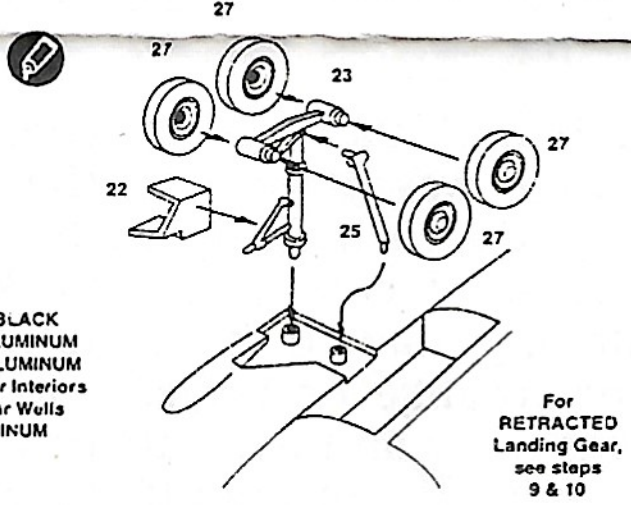

7 RIGHT MAIN L

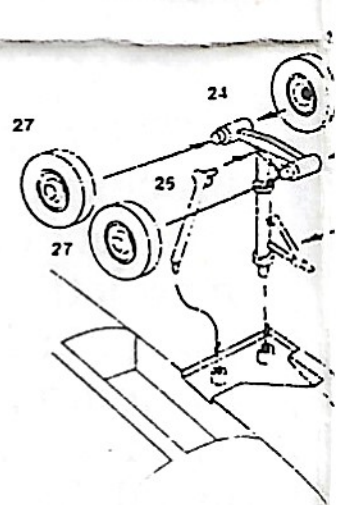

10 RETRACTED NOSE GEAR

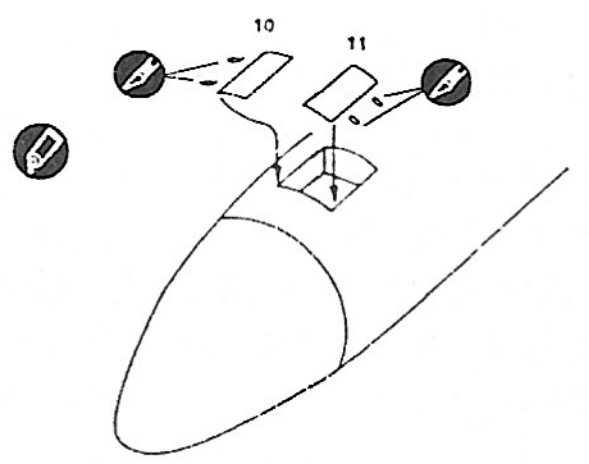

PARTS LAYOUT DIAGRAM 707-300

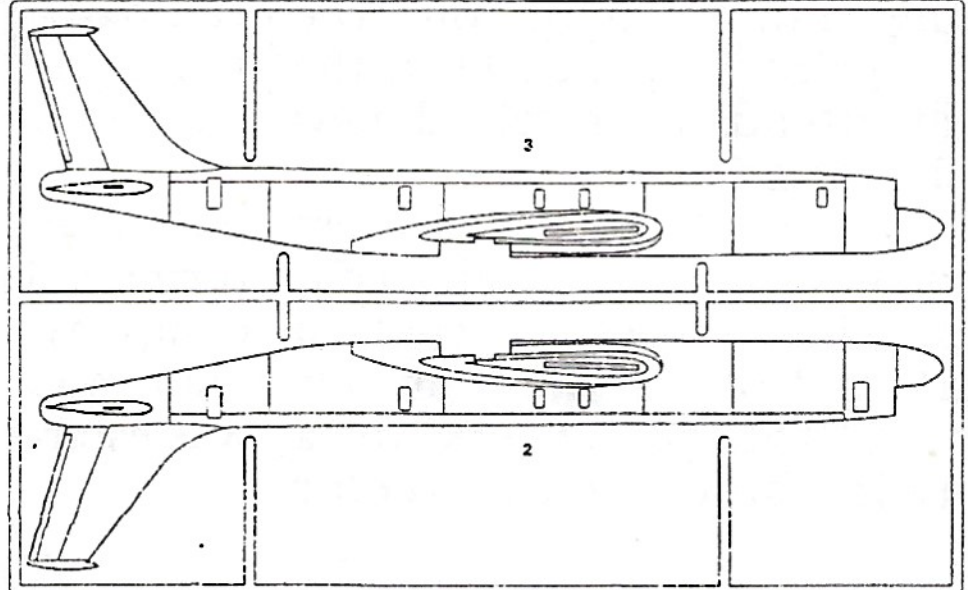

WING/FUSELAGE/STABILIZERS

NOTE
Due to the delicate nature of
the probe (part #44) you may
wish to attach it after painting
and decalling the model.

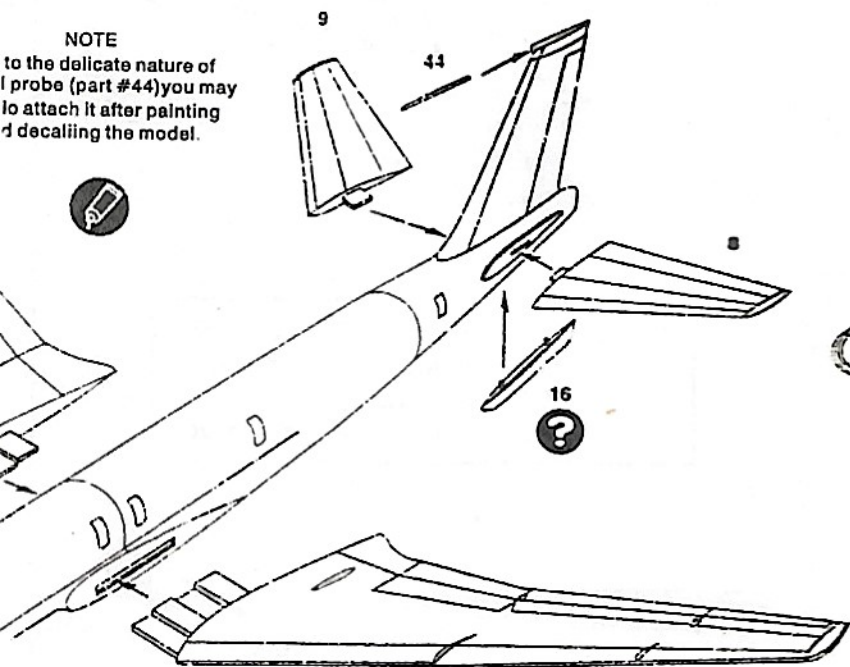

4 ENGINES/PYLONS

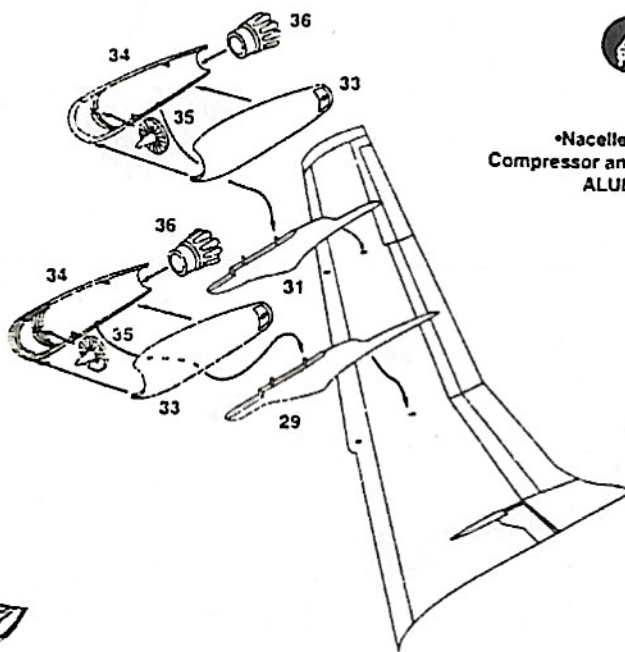

•Nacelle Interiors,
Compressor and Turbine Blades
ALUMINUM

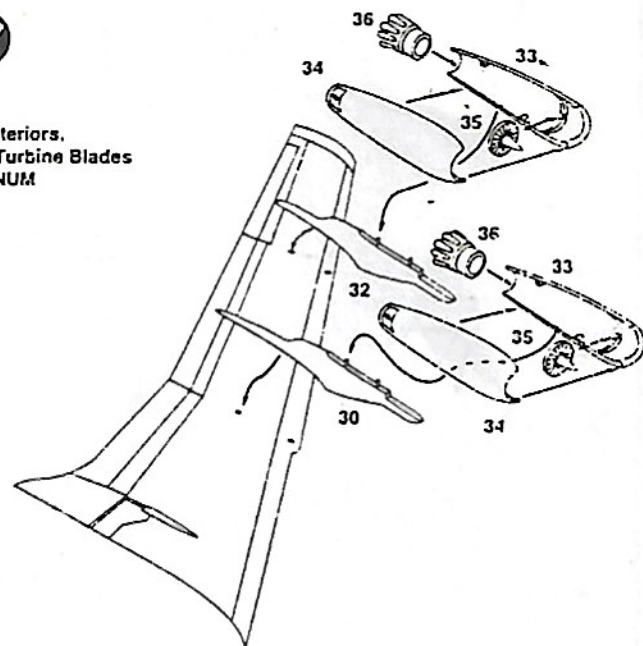

LANDING GEAR



8 NOSE LANDING GEAR

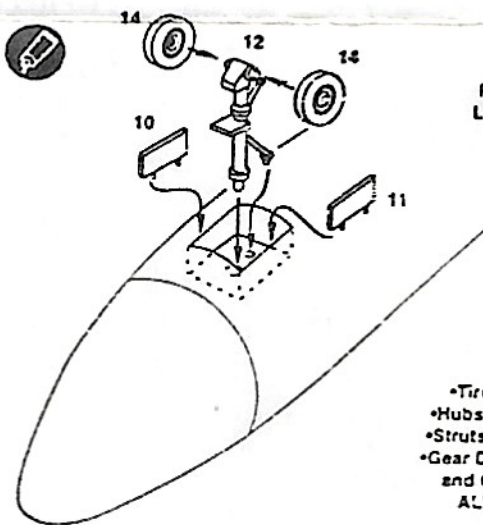

9 RETRACTED MAIN GEAR

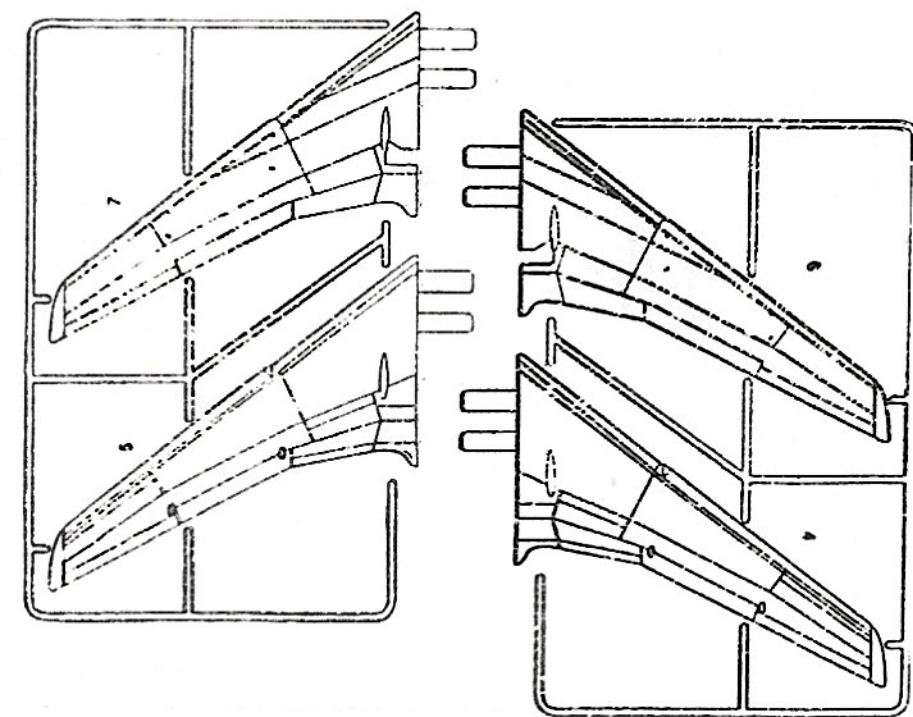
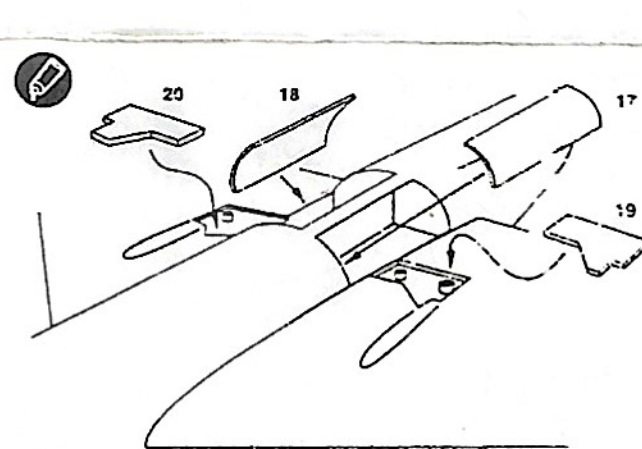

Shaded parts
not used

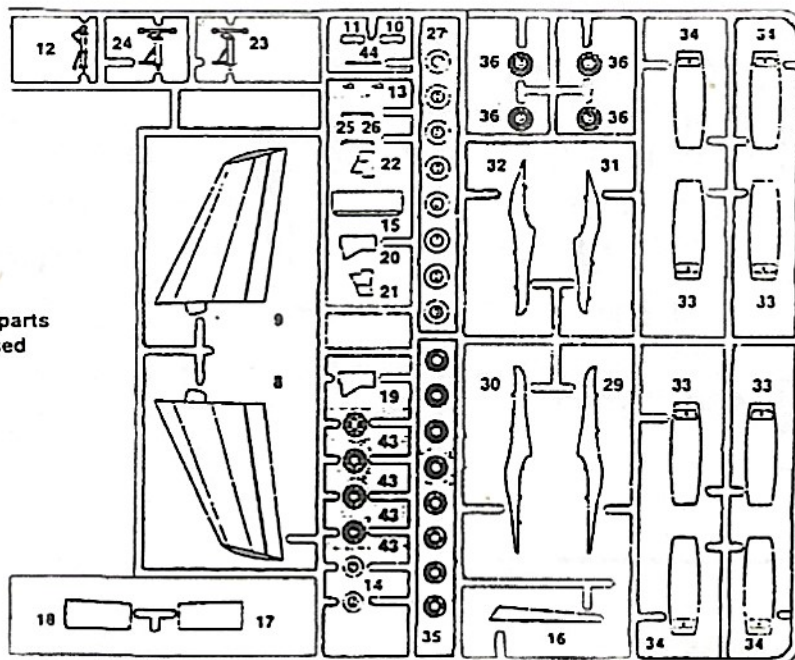

Revised Braniff Engine Assembly Instructions

4 ENGINES / PYLONS

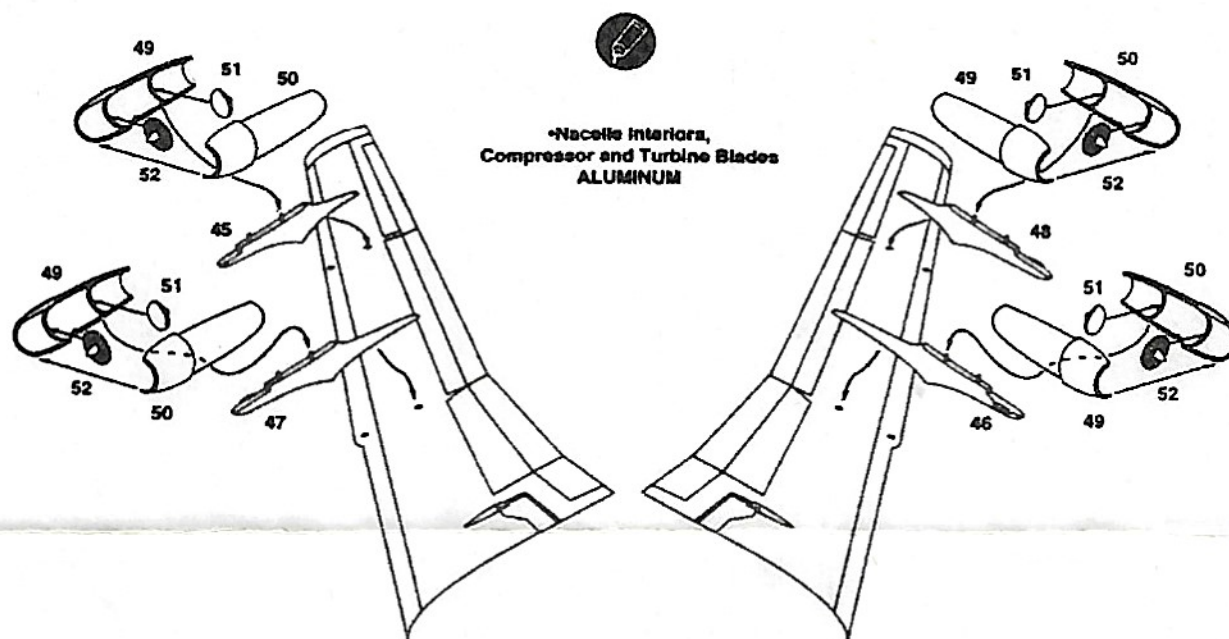

Part trees:

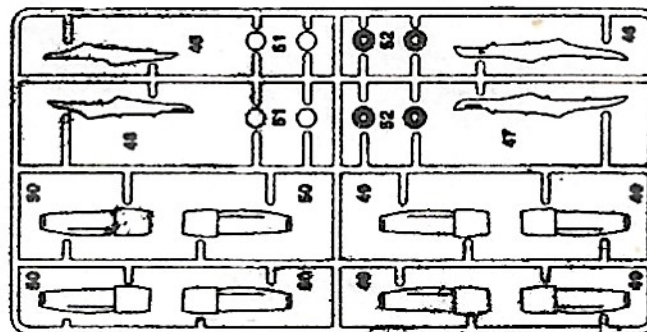
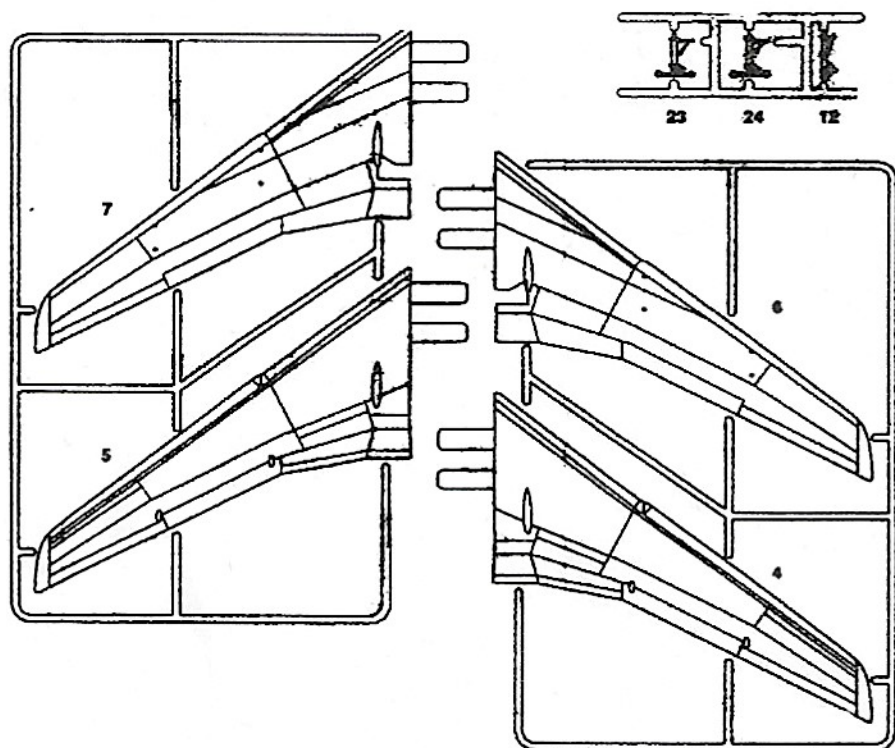

Shaded parts not for tow

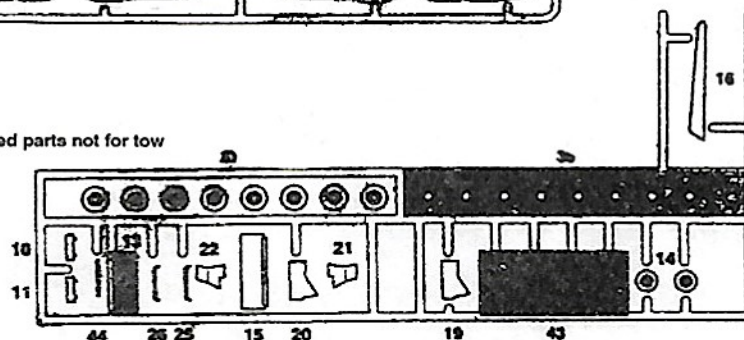

BRANIFF INTERNATIONAL BOEING 707

**Legends
in the making**

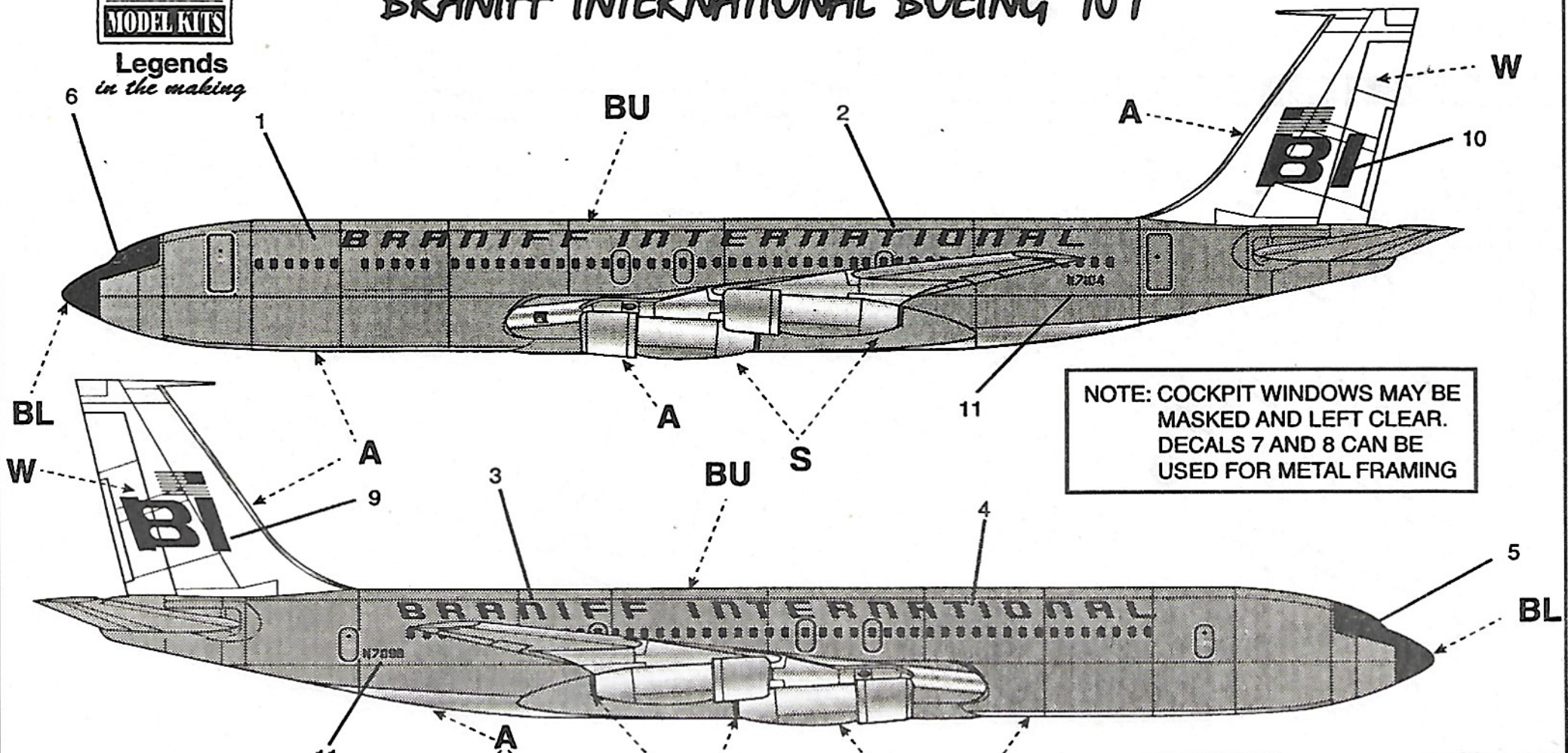

NOTE: COCKPIT WINDOWS MAY BE MASKED AND LEFT CLEAR. DECALS 7 AND 8 CAN BE USED FOR METAL FRAMING

BLUE: TESTOR 1110
 LT. BLUE: TESTOR 1108
 TURQUOISE: TESTOR 2765
 YELLOW: FS 13591
 BEIGE: PANTONE 126
 (NOTE THAT THESE ARE APPROXIMATE SHADES AND FOR REFERENCE ONLY)

*BRANIFF USED SEVERAL COLORS ON THEIR AIRPLANES.
 N7095 WAS PAINTED OCHRE
 N7096 WAS PAINTED YELLOW
 N7097 WAS PAINTED TURQUOISE
 N7098 WAS PAINTED ORANGE
 N7099 WAS PAINTED BLUE
 N7100 WAS PAINTED GREEN
 N7102 WAS PAINTED ORANGE
 N7103 WAS PAINTED BLUE N7076
 N7104 WAS PAINTED BEIGE

N105BN - RED
 107BN 1970
 72

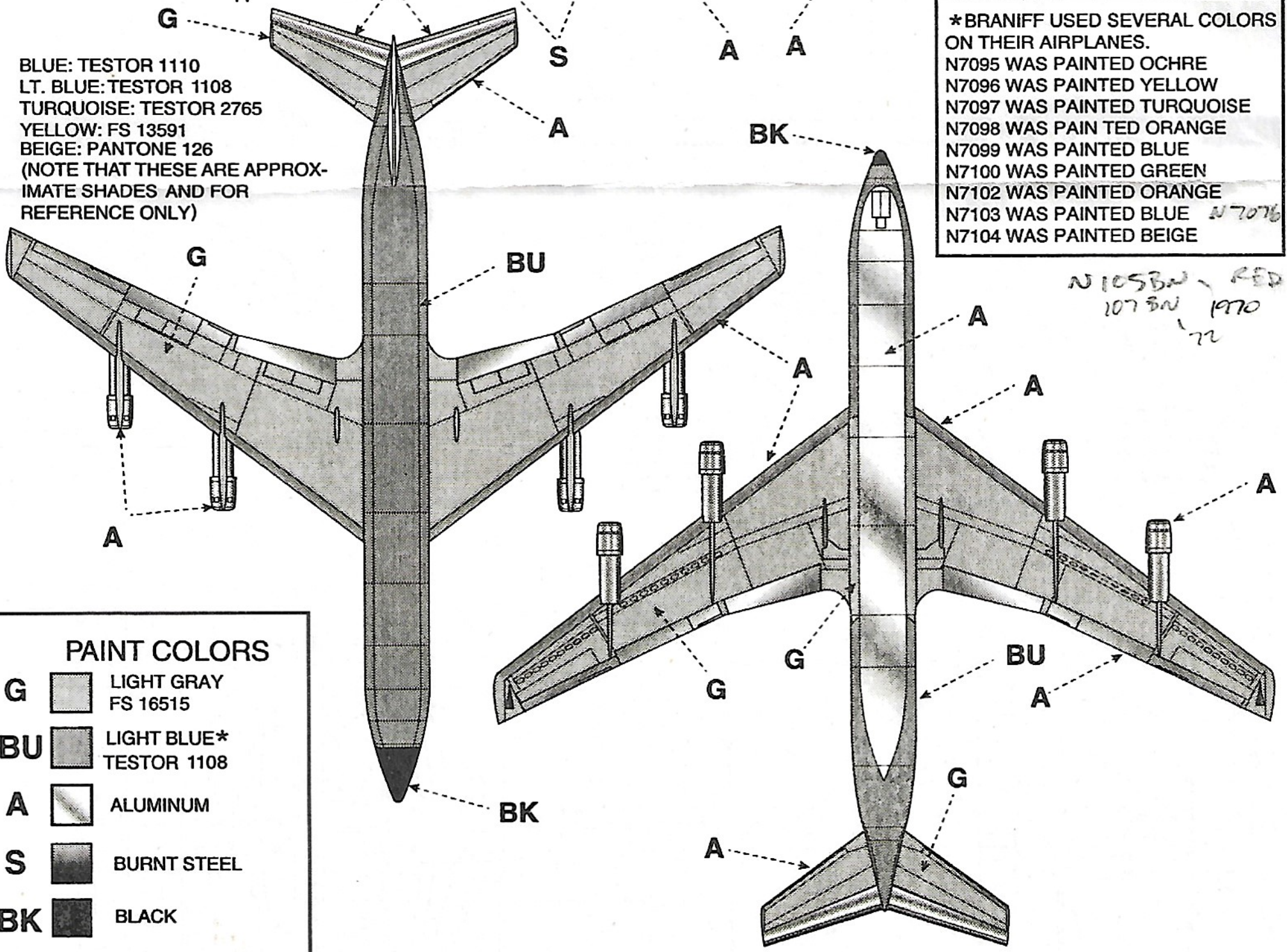

PAINT COLORS	
G	LIGHT GRAY FS 16515
BU	LIGHT BLUE* TESTOR 1108
A	ALUMINUM
S	BURNT STEEL
BK	BLACK

BRANIFF 707 #14502

MINICRAFT
MODEL KITS

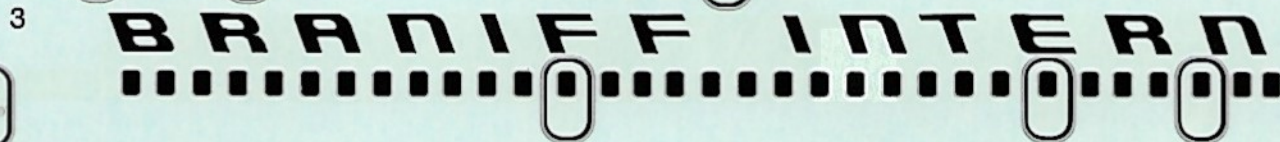

SCALE-MASTER®
DECALS
Award Winning Art



N7099 N7100 N7095 N7096
N7099 N7100 N7095 N7096

11
N7097 N7098
N7097 N7098
N7102 N7103 N7104
N7102 N7103 N7104

© 2002 MINICRAFT MODELS INC.
ALL RIGHTS RESERVED