

# Spitfire Mk VB

MOST FAMOUS FIGHTER OF WORLD WAR II

**mpe**  
78 - 4007 - 250





Designed by R.J. Mitchell and making its first flight on March 5, 1936, the Spitfire entered service two years later with 19 Sqn RAF. Calibrated trials showed a maximum speed of 354 m.p.h. at 18,900 ft and its original armament of eight wing-mounted .303 in machine guns gave a formidable rate of fire of 1,200 rounds per minute. The Mk VB was introduced in 1941 having a Rolls-Royce Merlin 45 engine rated at

1,470 h.p. for combat and armed with two 20 mm cannon and four Browning machine guns. More than 5,000 Spitfire VBs were built and served in Russia, the Middle and Far East, as well as in Northern Europe. Top speed 371 m.p.h. at 20,100ft; service ceiling 37,500ft.

Decals in this kit are for the RAF Kosciuszko Squadron from that period.

## IMPORTANT! READ THIS FIRST

- Study assembly drawings carefully before starting.
- Each part is identified by a part number (14).
- Scrape paint from areas to be cemented.
- Before cement is used, check the fit of each part.
- Use only enough cement to join parts.
- Apply cement to small parts with a toothpick.
- Use cement made for styrene plastic only.
- Allow paint to dry thoroughly before handling.
- Your model may be painted to match the box photos.
- Cement all parts except where Do Not Cement symbol  is shown.
- Follow the step numbers 5 in each assembly drawing.
- ★ Refer to other assembly drawing for location.
- Refer to last page for decal and painting instructions.

- 5 — STEP NUMBERS
- 32 — PLASTIC PART NUMBERS
-  — OPTIONAL
-  — DO NOT CEMENT
-  — CEMENT HERE ONLY
- 2X — REPEAT SEVERAL TIMES
-  — REMOVE
- ★ — REFER TO ....
-  — DECAL

© 1982 Fundimensions, Division of CPG Products Corp.

1

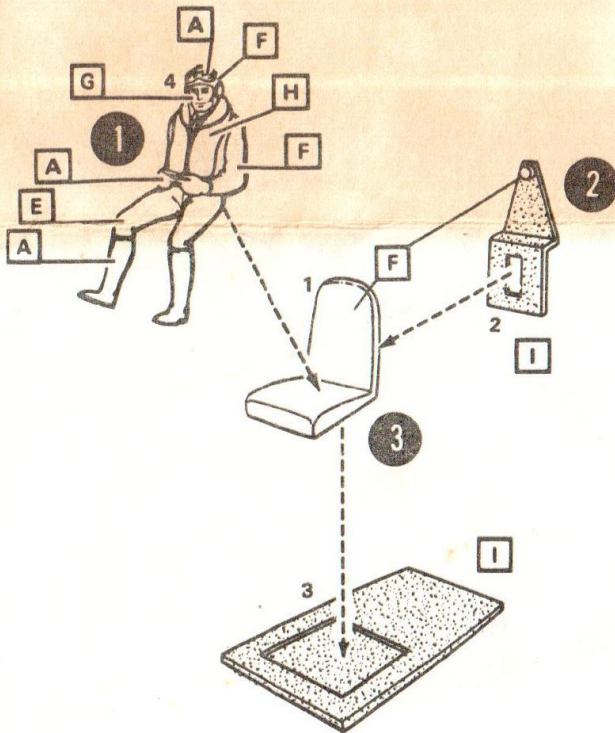

2

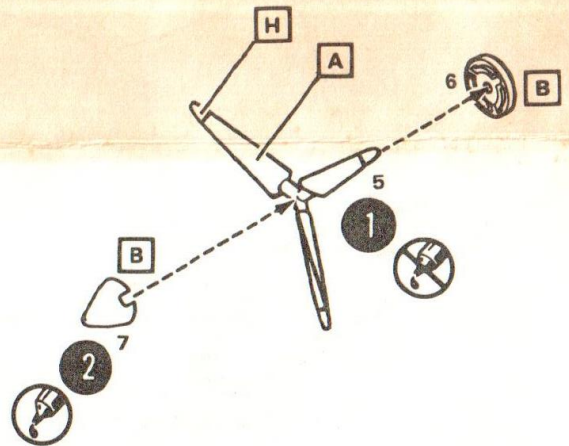



### 3

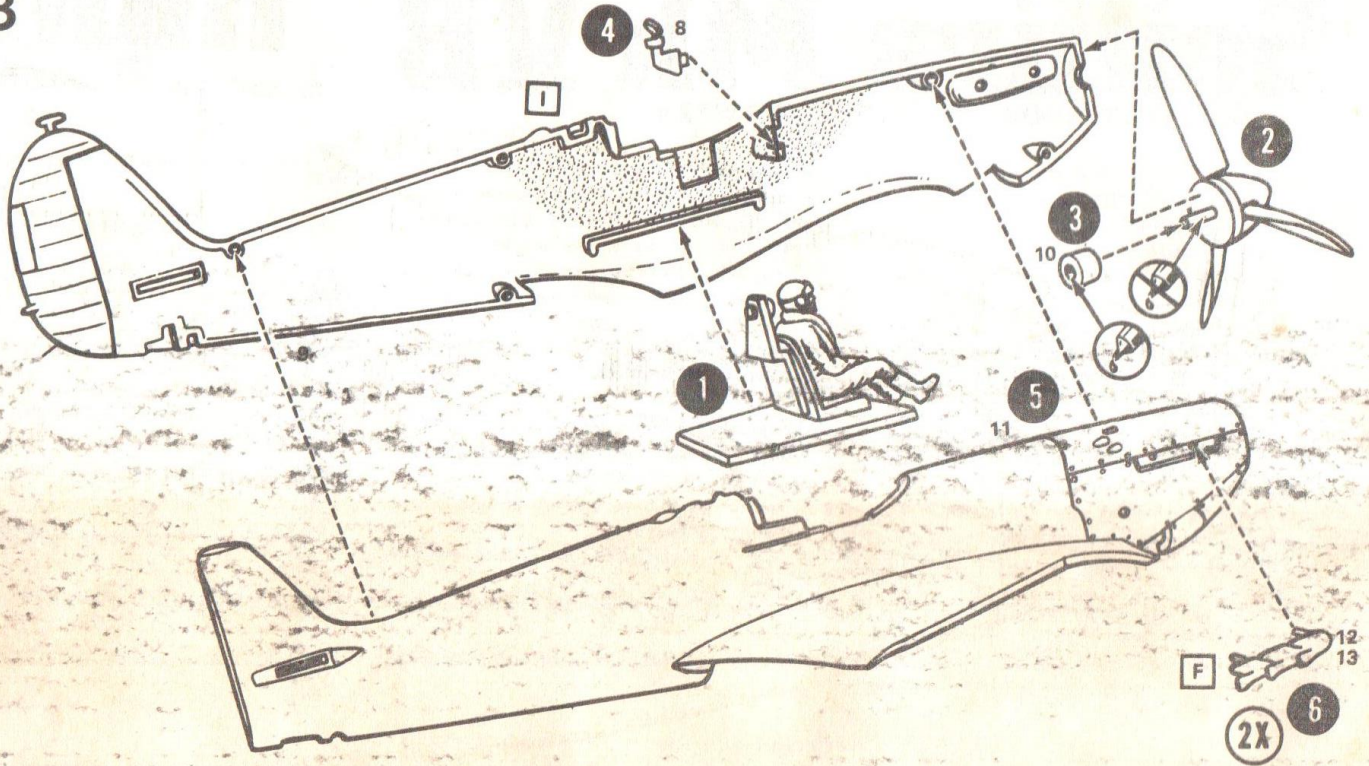

### 4

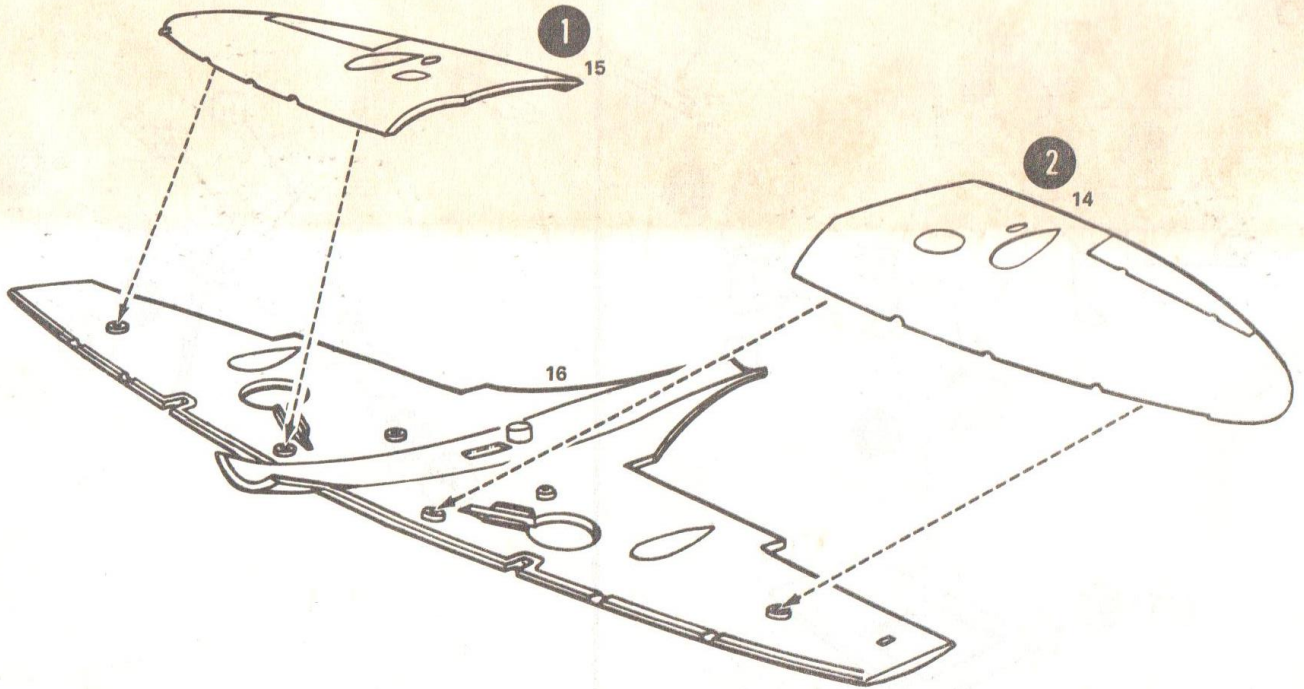

5

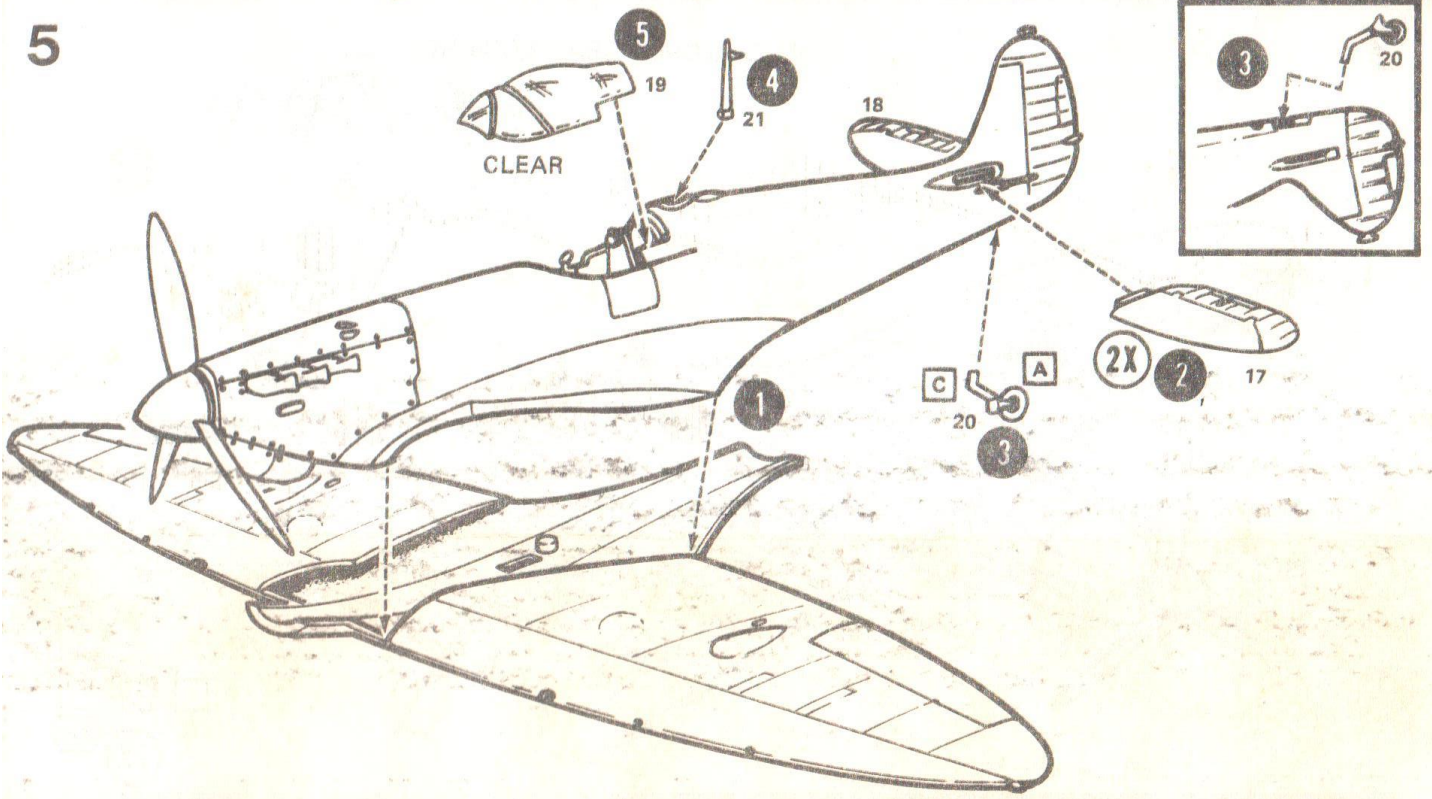

6

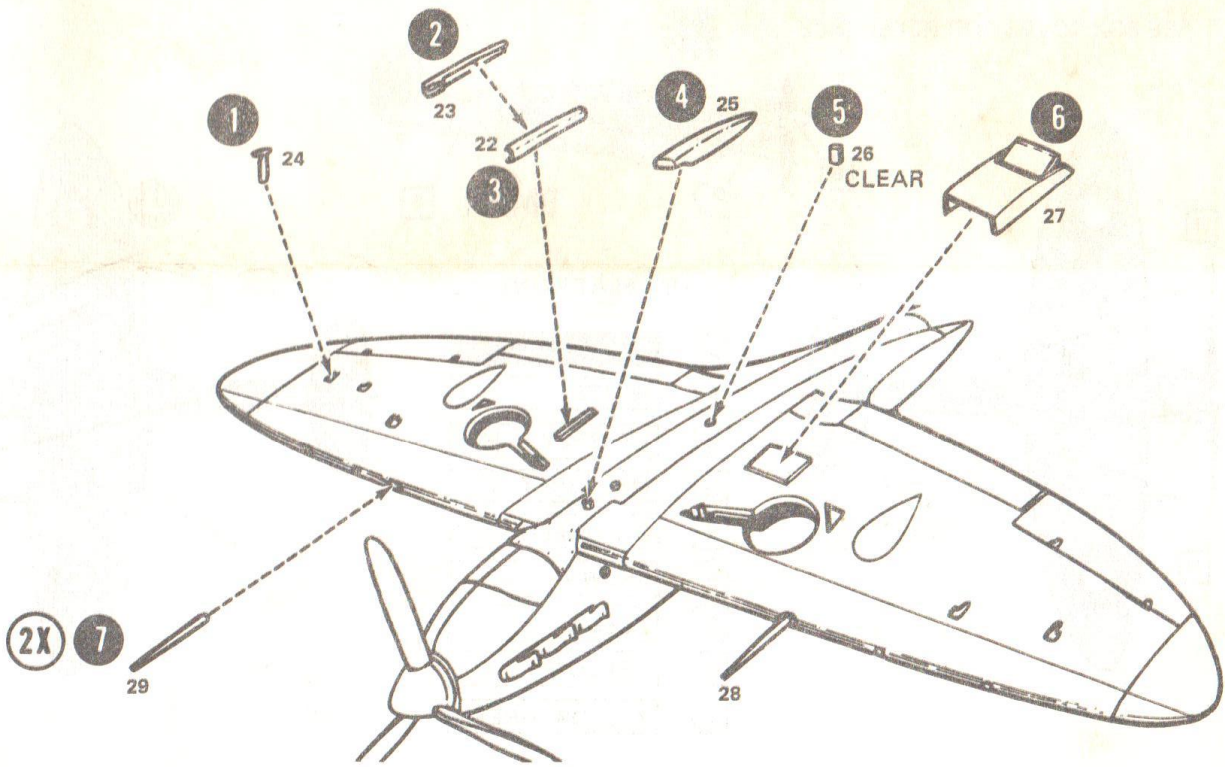



7

LANDING GEAR LOWERED

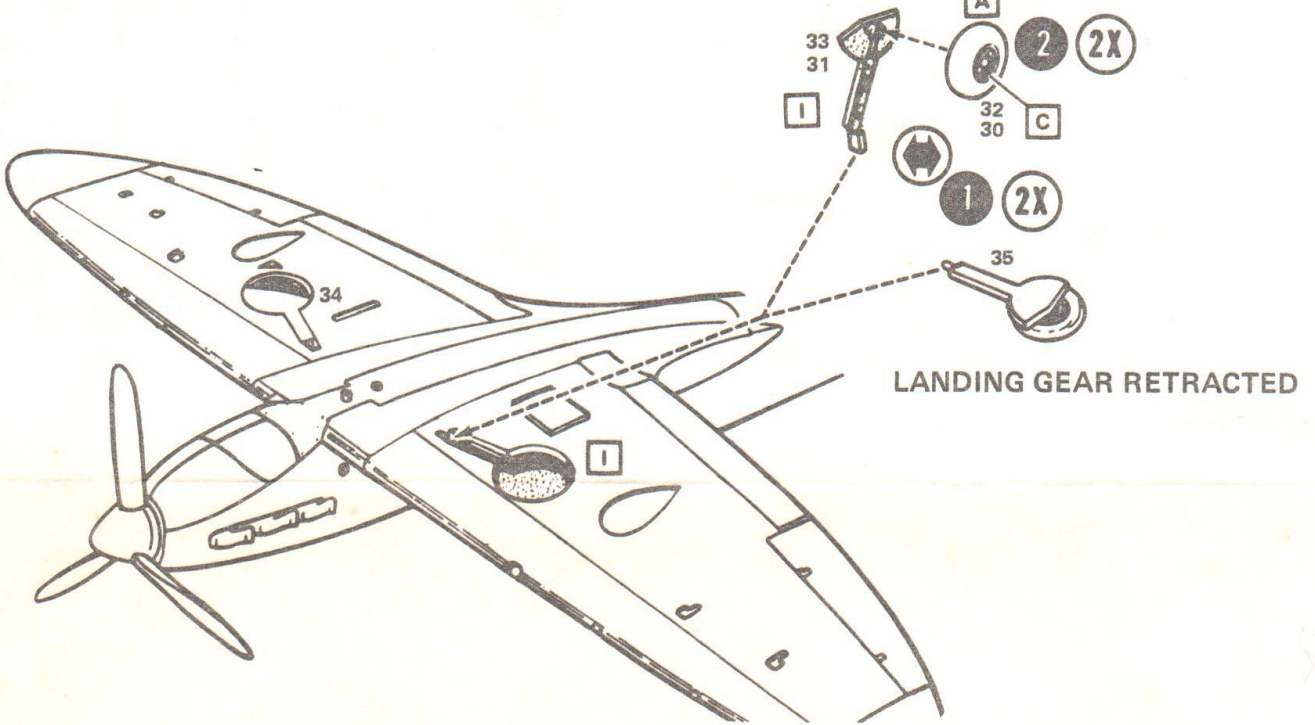

8 SEE BOX COVER FOR REFERENCE

