

British WWII Heavy Bomber 1:72 SCALE PLASTIC KIT

eduard



ProfiPACK

intro

The Consolidated B-24 Liberator four-engined heavy bomber is one of WWII's flying legends. Along with another famous bomber, the Boeing B-17 Flying Fortress, it helped gain victory over the Third Reich, and in large numbers served on the other side of the world, against the Japanese armed forces.

The first prototype made its maiden flight on December 29, 1939 and more than 18,000 Liberators were built by the end of World War II. This number consists of many versions - bombers, recce and transport airplanes. Mass production was undertaken in five assembly plants and at its peak produced up to 650 aircraft per month. The assembly plants were operated by Consolidated in San Diego and Fort Worth, by Ford in Willow Run, by Douglas in Tulsa, and by North American, also in Dallas.

Apart of the US air forces, the Liberator was flown by air forces of other nations. The Royal Air Force obtained around 2100 aircraft. Approximately 1600 of them were B-24H, J and L models, the latter being redesignated by the British as Liberator VI / VIII. These aircraft were supplied under the Lend-Lease agreement between the spring of 1944 and August of 1945.

Liberators B. VIs, that can be built from this kit, were produced by the Fort Worth plant as B-24Js, Block 86, 90 and 91.

Our markings offer aircraft that served with No. 99, 159 and 356 Squadrons, RAF. All three units were subordinate to No. 231 Group, RAF. This Group was a part of Air Command South East Asia - ACSEA. This Air Command controlled all the air forces of the RAF and USAAF located in India, Burma and Indonesia, a total of 1500 aircraft in early 1945. This aerial armada outnumbered Japanese air force and enabled an efficient support to the war operation that led to the final defeat of the Empire of the Rising Sun.

No. 99 Squadron obtained its first Liberator B. VIs in September 1944. The new aircraft replaced Wellington B. Xs. The squadron was based in Dhubalia airfield. The detachments used Agartala and Kumbhirgram airfields as their home bases. In the very final stage of the war, No. 99 Squadron moved to the Coco Islands, southwest off Java. The squadron marking consisted of a white disc on the black fin.

No. 159 Squadron flew Liberator B. VIs from March 1944 to July 1945 when these were replaced by Liberator B. VIIIs. The squadron's home base was Madhaiganj, India, quickly replaced by Digri, situated in today's Pakistan. The detached flights were based out of various airfields in Burma - Akyab or Pegu for example. No specific marking was used by this squadron.

No. 356 Squadron was established in January 1944 at Salbani, India. The first combat mission was flown on July 27, 1944. The crews used their Liberator B. VIs for bombing as well as mining. From July 1945 on, the squadron operated from the Coco Islands but only one bombing mission against Japanese targets was flown. After the Japanese surrender, the squadron flew a lot of missions focused on searching for lost aircraft and supply drops. The last flight was made on November 12, 1945 and the unit was disbanded three days later. The squadron's typical marking was a black rudder with a white diagonal cross.

Těžký čtyřmotorový bombardér Consolidated B-24 Liberator se nesmazatelně zapsal do dějin leteckých bojů v období 2. světové války. Po boku neméně proslulého typu Boeing B-17 Flying Fortress pomáhal porazit německou Třetí říši, ve velkých počtech válčil také na druhé straně zeměkoule, proti japonským ozbrojeným silám.

První prototyp vzletl dne 29. prosince 1939 a do konce války se podařilo postavit přes 18 000 exemplářů. Tento počet zahrnoval řadu verzí nejrůznějšího zaměření. Od bombardérů, přes průzkumné stroje až po letouny dopravní. Masová výroba postupně naběhla v pěti továrnách a v roce 1944 se podařilo dosáhnout měsíční produkce až 650 kusů. Podílely na ní dvě továrny společnosti Consolidated (San Diego a Fort Worth) a též licenční výroba u Fordu ve Willow Run, u North American v Dallasu a u Douglasu v Tulse.

Kromě amerických ozbrojených sil jej do své výzbroje zařadily další státy – Velkou Británií nevyjímaje. Do řad RAF se dostalo okolo 2100 exemplářů.

Stroje Liberator B. VI, které si můžete postavit z této stavebnice, vyprodukovala továrna ve Fort Worth jako B-24J, výrobní bloky 86, 90 a 91.

Vybrali jsme pro vás letouny, které sloužily u No. 99, 159 a 356 Squadrony RAF. Všechny tři jednotky patřily do No. 231 Group RAF, která byla v roce 1945 podřízena Leteckému velitelství Jihovýchodní Asie (Air Command South East Asia – ACSEA). Tento stupeň velení zahrnoval síly RAF a USAAF umístěné v Indii, Barmě a Indonésii a na počátku roku 1945 čítal na 1500 letounů. Tento počet značně převyšoval počty japonských letounů a umožňoval tak efektivní podporu válečného snažení, které směřovalo k definitivní porážce Japonska.

No. 99 Squadrona RAF dostala první Liberator B. VI v září 1944 jako náhradu za Wellingtony B. X. V té době působila ze základny Dhubalia. Odloučené části se nacházely na letištích Agartala a Kumbhirgram. V samém závěru války, v srpnu 1945 se novým působištěm No. 99 Squadrony staly Kokosové ostrovy, ležící jihozápadně od Jávy. Marking identifikující stroje této Squadrony zahrnoval černou svislou ocasní plochu s bílým terčem.

No. 159 Squadrona RAF používala Liberator B. VI v období od března 1944 do července 1945, kdy je vyměnila za Liberator B. VIII. V březnu ještě pobývala v indickém Madhaiganj, ale již od dubna působila z letiště Digri, které leží na území dnešního Pákistánu. Detašmány pak využívaly různá letiště v Barmě, namátkou třeba Akyab, Pegu apod. Na strojích této jednotky se neobjevoval žádný výrazný marking, který by pro ně byl typický.

No. 356 Squadron RAF byla ustavena 15. ledna 1944 v indickém Salbani. Do operací poprvé zasáhla 27. července 1944. Výzbroj tvořily Liberator B VI, s nimiž piloti létali bombardovací mise a kladlí miny. Od července 1945 létala již z nového působiště, jímž byly Kokosové ostrovy. Z těchto ostrovů v Indickém oceánu provedla pouze jedinou bombardovací misi proti japonským základnám v Indonésii.

E KH 284, 'Donald III', No. 356 Squadron RAF ACSEA, 1945

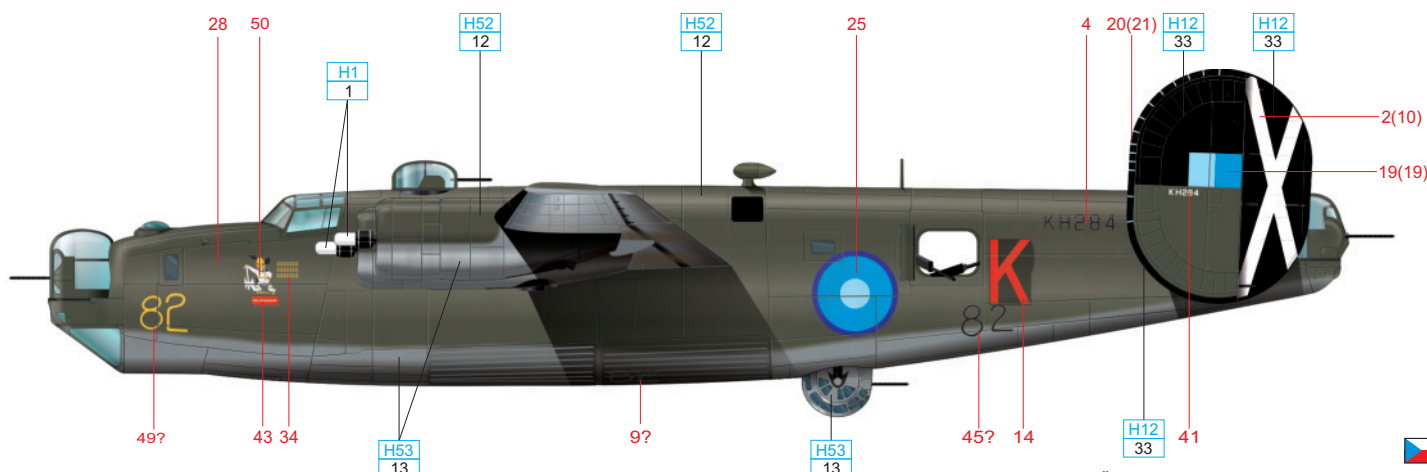

ATTENTION



UPOZORNĚNÍ



ACHTUNG



ATTENTION



注意



Carefully read instruction sheet before assembling. When you use glue or paint, do not use near open flame and use in well ventilated room. Keep out of reach of small children. Children must not be allowed to suck any part, or pull vinyl bag over the head.



Před započetím stavby si pečlivě prostudujte stavební návod. Při používání barev a lepidel pracujte v dobře vetrané místnosti. Lepidla ani barvy nepoužívejte v blízkosti otevřeného ohně. Model není určen malým dětem, mohlo by dojít k požití drobných dílů.



lire soigneusement la fiche d'instructions avant d'assembler. Ne pas utiliser de colle ou de peinture à proximité d'une flamme nue, et aérer la pièce de temps en temps. Garder hors de portée des enfants en bas âge. Ne pas laisser les enfants mettre en bouche ou sucer les pièces, ou passer un sachet vinyl sur la tete.



Von dem Zusammensetzen die Bauanleitung gut durchlesen. Kleber und Farbe nicht nahe von offenem Feuer verwenden und das Fenster von Zeit zu Zeit Belüftung öffnen. Bausatz von kleinen Kindern fernhalten. Verhüten Sie, daß Kinder irgendwelche Bauteile in den Mund nehmen oder Plastiktüten über den Kopf ziehen.



組み立てる前に必ず説明書をお読み下さい。接着剤や塗料をご使用の際は、窓を開けて十分な換気をおこない、火のそばでは使用しないで下さい。小さな子供の手の届かない所に必ず保管してください。部品や破片を噛んだり、なめたり、飲んだりすると大変危険です。又、部品を取り出した後のビニール袋は、小さな子供が頭から被ったりすると窒息する恐れがありますので、破り捨ててください。

INSTRUCTION SIGNS * INSTR. SYMBOL * INSTRUKTION SINNBILDEN * SYMBOLES * 記号の説明



OPTIONAL
VOLBA
FACULTATIF
NACH BELIEBEN
選択する



BEND
OHNOUT
PLIER SIL VOUS PLAIT
BITTE BIEGEN
折る



OPEN HOLE
VYVRTAT OTVOR
FAIRE UN TROU
OFFNEN
穴を開ける



SYMETRICAL ASSEMBLY
SYMETRICKÁ MONTÁŽ
MONTAGE SYMÉTRIQUE
SYMMETRISCHE AUFBAU
左右均等に組み立てる



NOTCH
ZÁŘEZ
L INCISION
DER EINSCHNITT
切る



REMOVE
ODŘÍZNOUT
RETIRER
ENTFERNEN
移す



APPLY EDUARD MASK
AND PAINT
POUŽIT EDUARD MASK
NABARVIT

PARTS



DÍLY



TEILE



PIÈCES



部品

PLASTIC PARTS

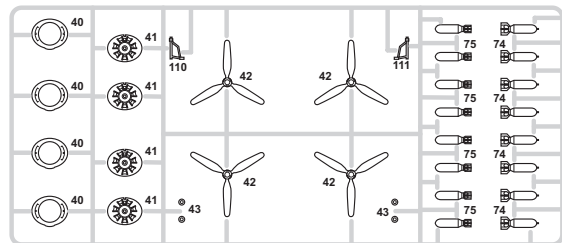
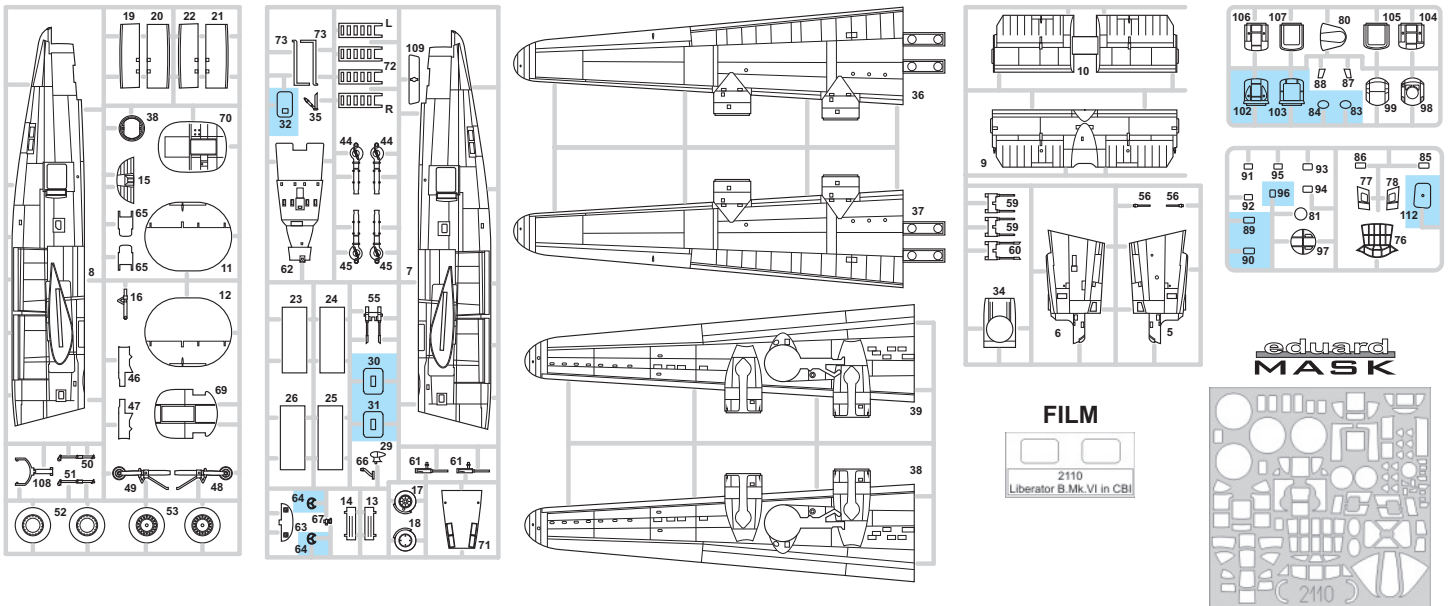

PE - PHOTO ETCHED
DETAIL PARTS

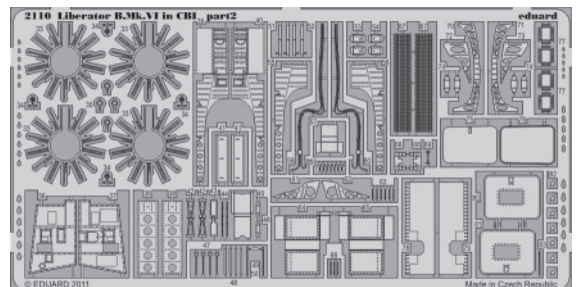

-Parts not for use. -Teile werden nicht verwendet. -Pièces à ne pas utiliser. -Tyto díly nepoužívejte při stavbě. - 使用しない部品

COLOURS



BARVY



FARBEN



PEINTURE



色

GSI Creos (GUNZE)		
AQUEOUS	Mr.COLOR	
[H 1]	[C1]	WHITE
[H 3]	[C3]	RED
[H 4]	[C4]	YELLOW
[H 8]	[C8]	SILVER
[H 12]	[C33]	FLAT BLACK
[H 18]	[C28]	STEEL
[H 52]	[C12]	OLIVE DRAB

GSI Creos (GUNZE)		
AQUEOUS	Mr.COLOR	
[H 53]	[C13]	NEUTRAL GRAY
[H 58]	[C27]	INTERIOR GREEN
[H 77]	[C137]	TIRE BLACK
[H 344]	[]	RUST
Mr.METAL COLOR		
[MC214]	[]	DARK IRON

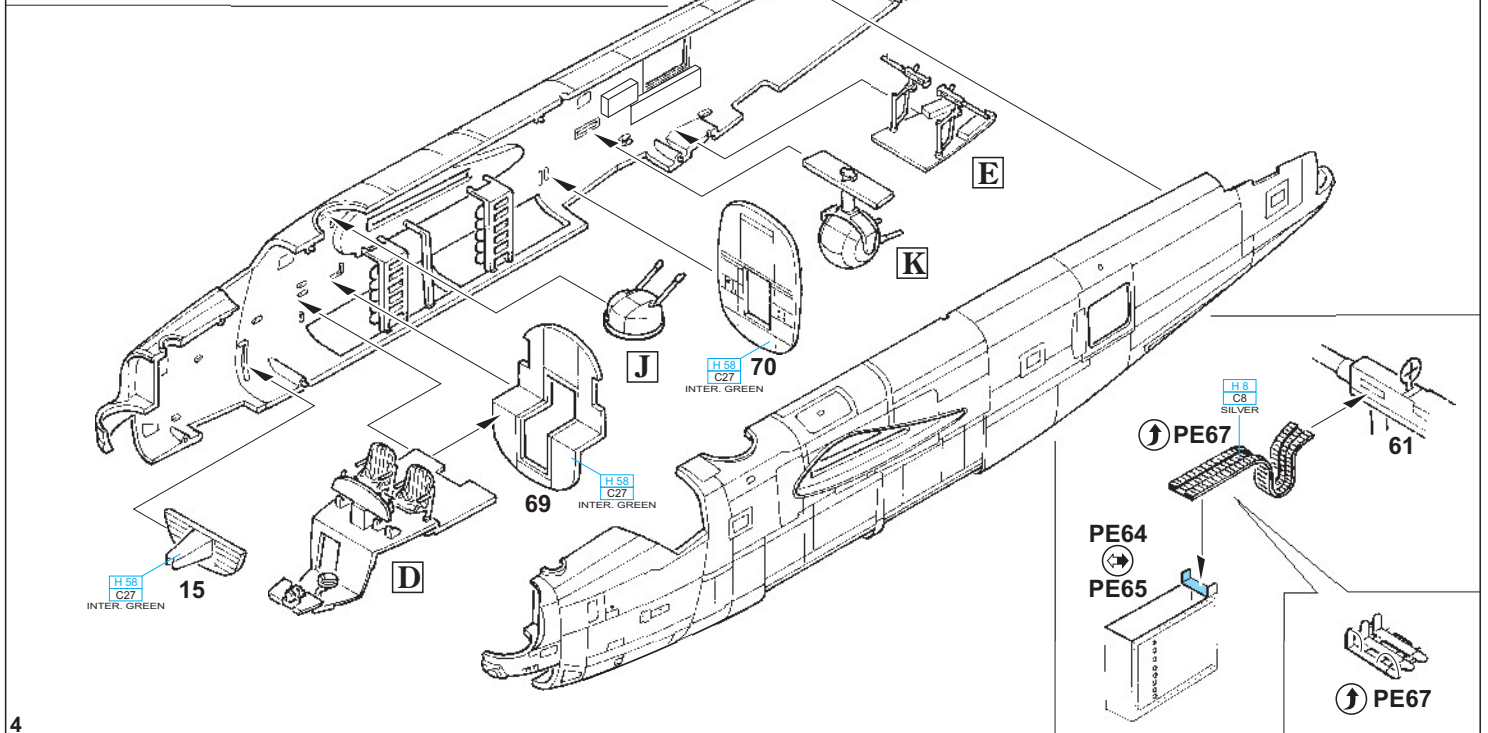
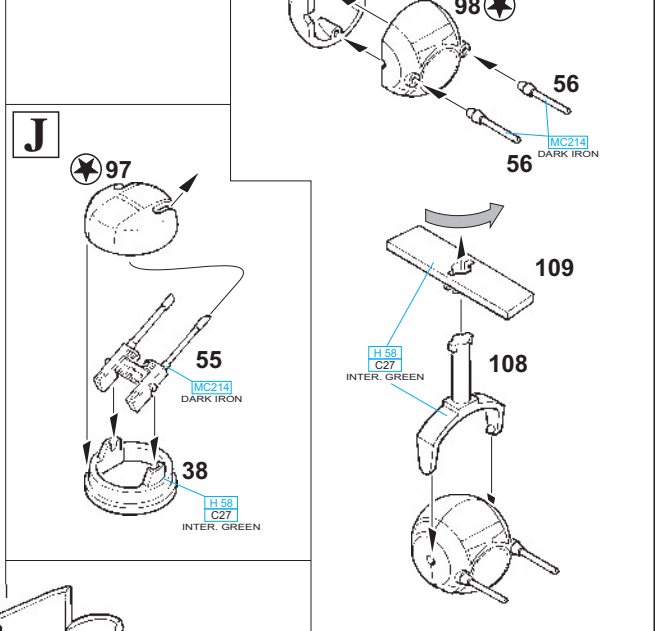
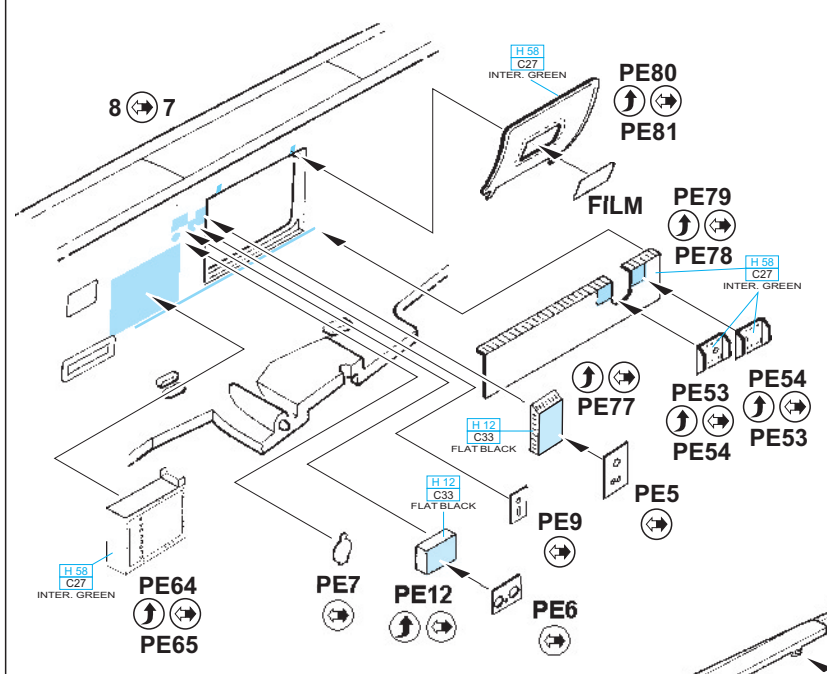
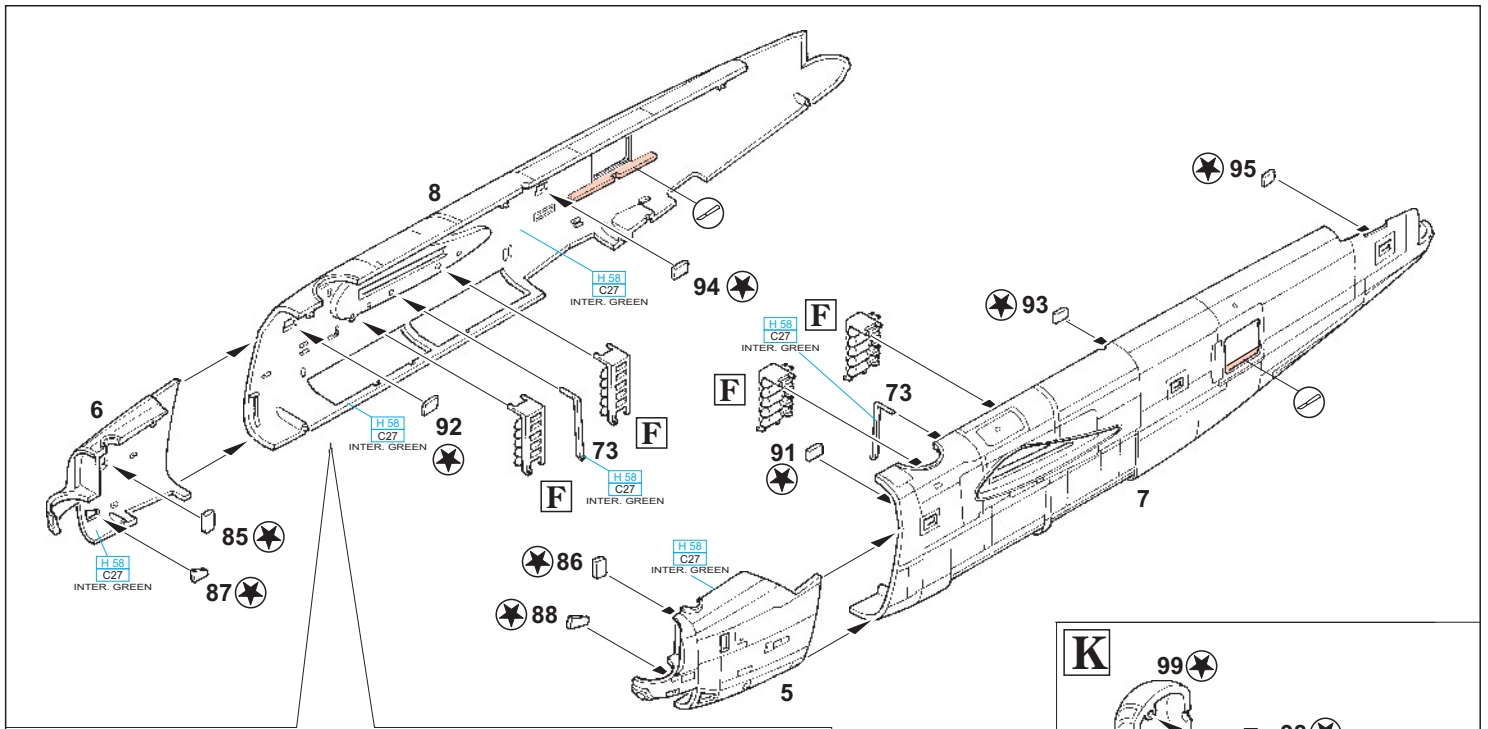

PE73
PE72

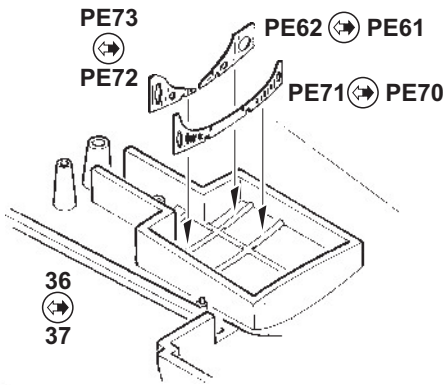

36
37

L

107

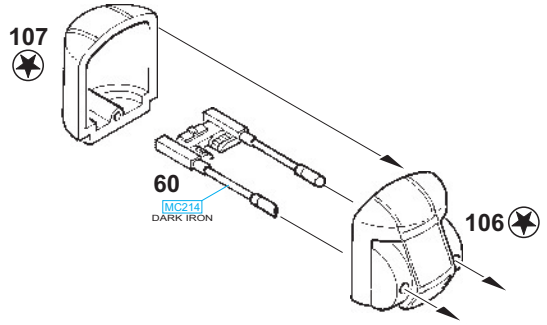

60
MC214
DARK IRON

106

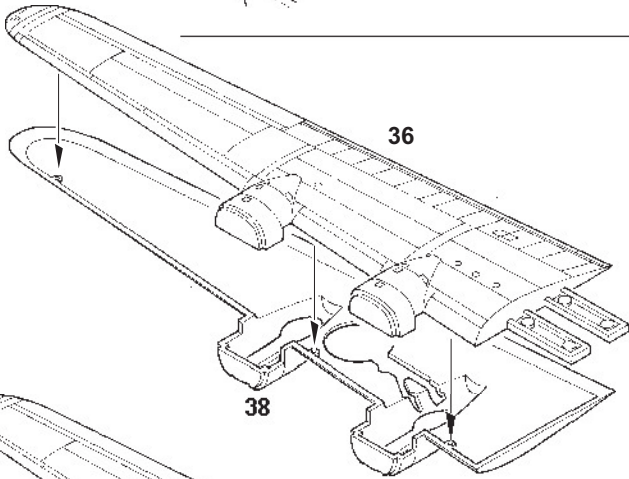

36

37

38

39

PE83

29

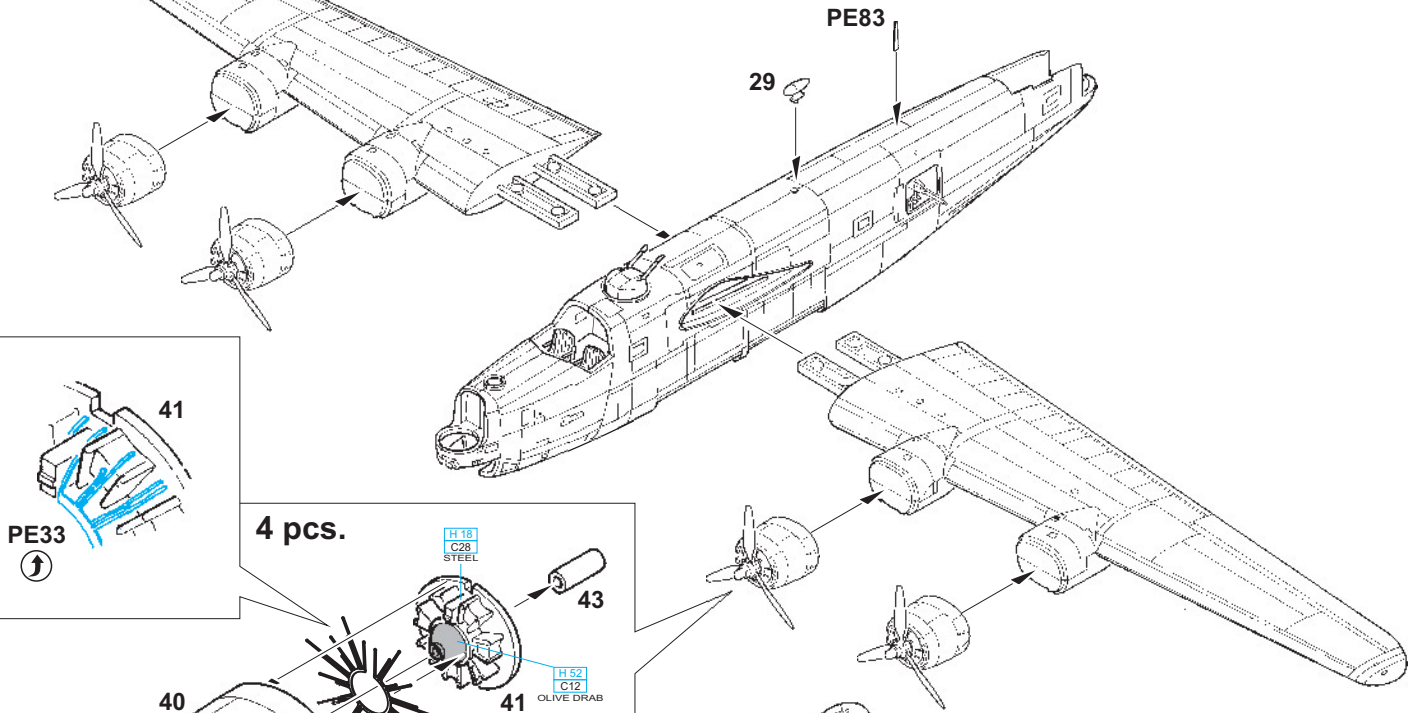

PE33

41

4 pcs.

H 18
C28
STEEL

43

H 52
C12
OLIVE DRAB

H 12
C33
FLAT BLACK

PE33

40

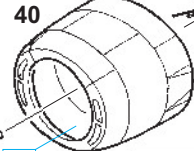

H 58
C27
INTER. GREEN

42

12

L

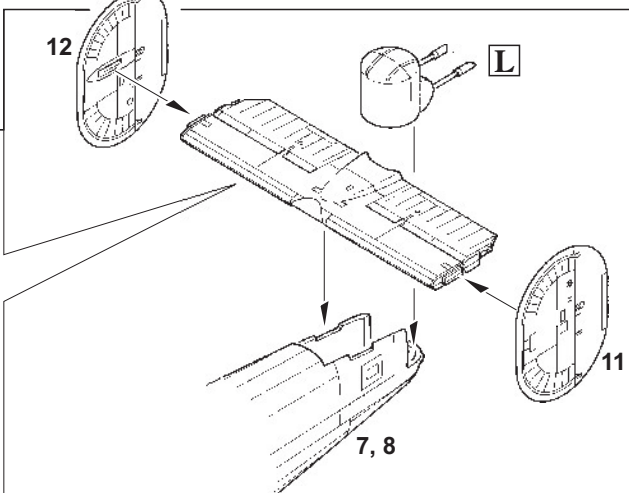

9

10

7, 8

11

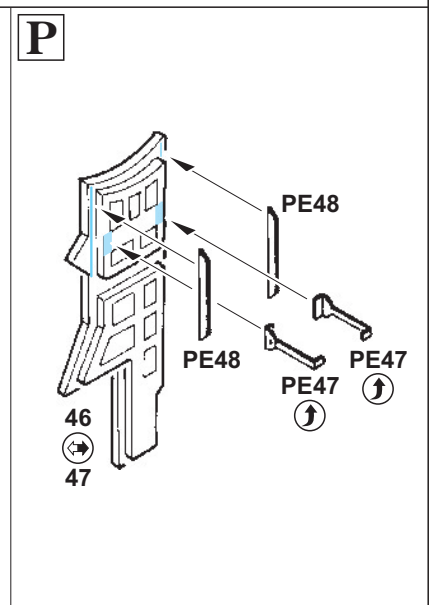
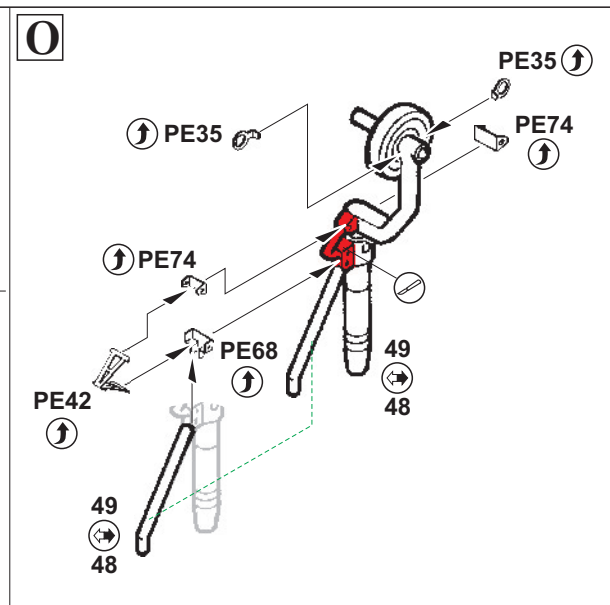
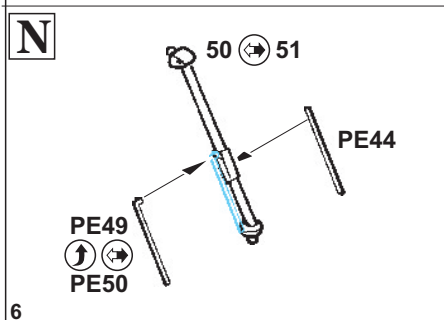
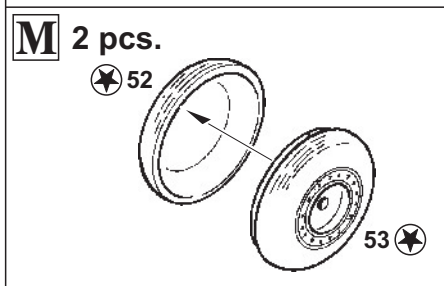
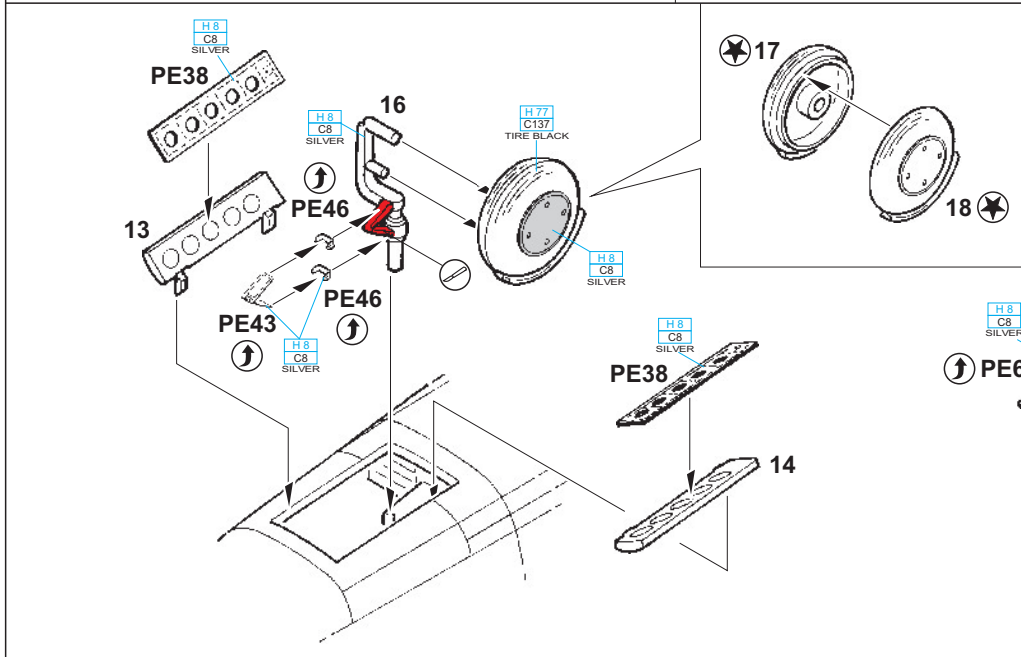
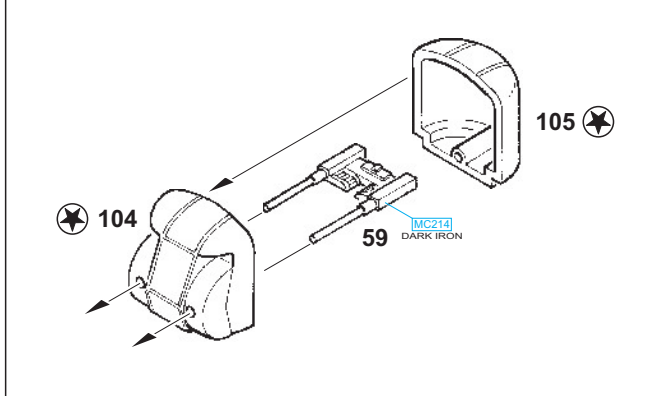
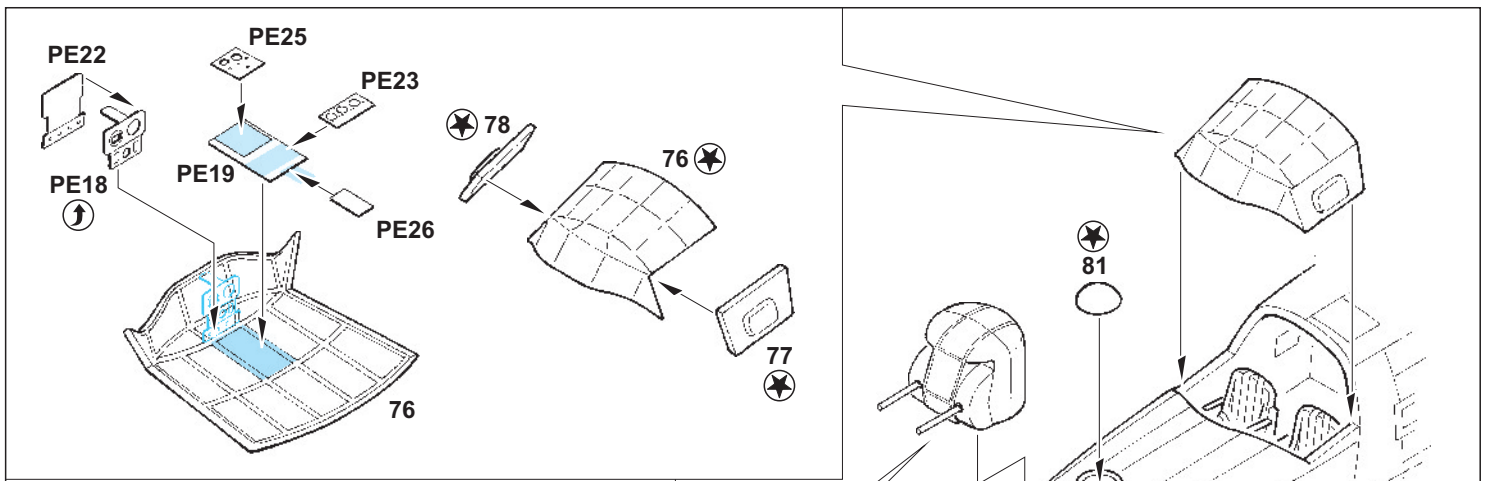

2 pcs.

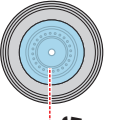

53



18

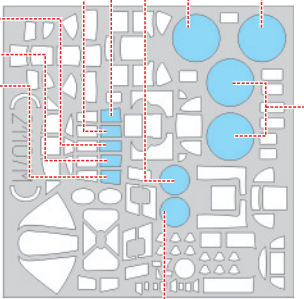

52

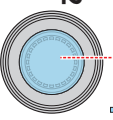

2 pcs.

17

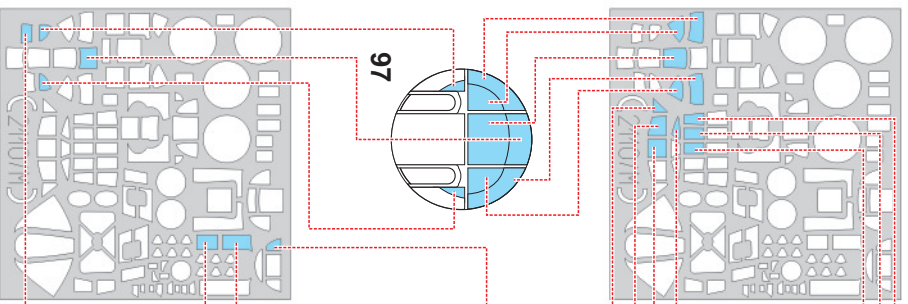

97

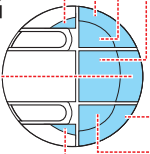

97

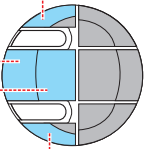

107

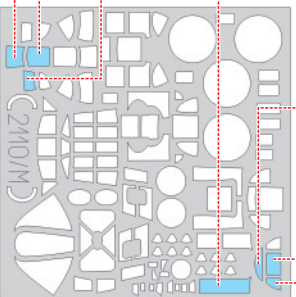
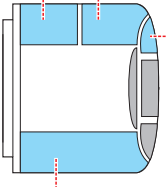

107

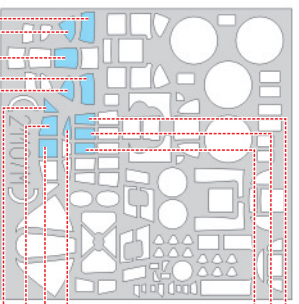
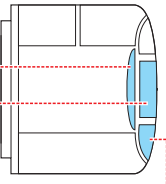

76

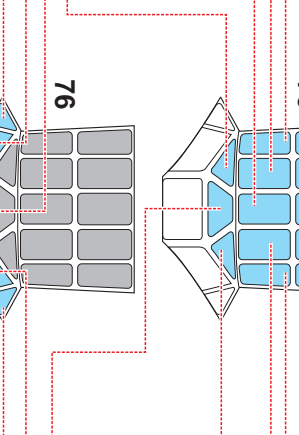
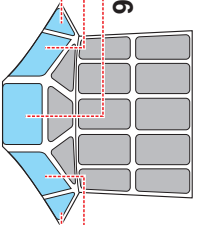

76

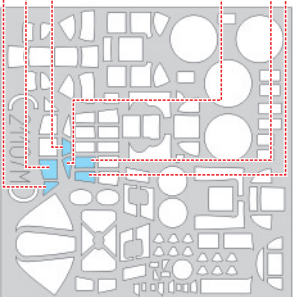
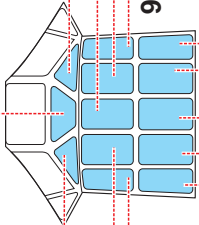

76

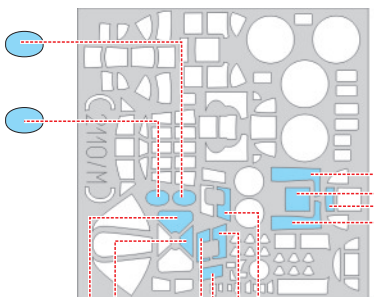

102

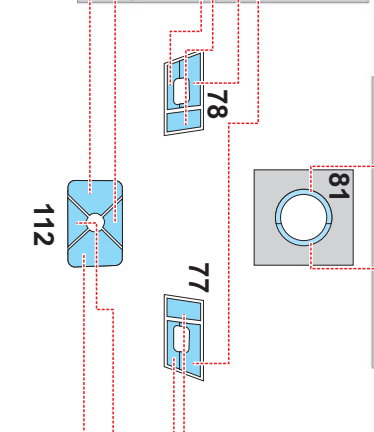
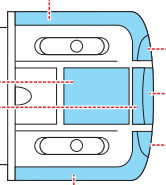

83

84



112

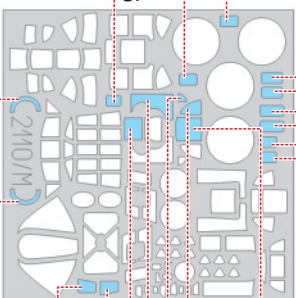
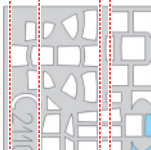

91

92

96

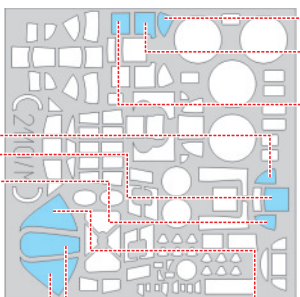

80

85

86

89

90

94

95

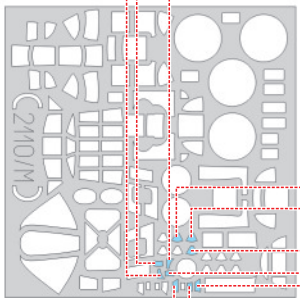
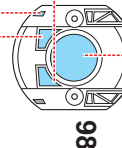
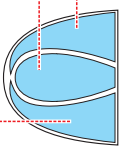

98

99

99

98

99

99

99

98

99

98

99

98

99

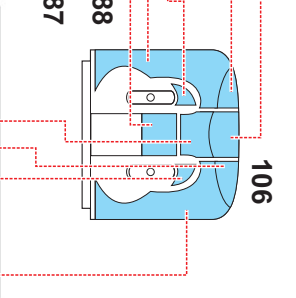

106

87

88

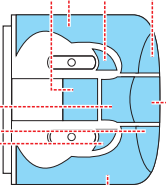

A KH 211, 'Audrey's Back', No. 99 Squadron RAF ACSEA, Coco Islands, August 1945

'Audrey's Back' artwork was inspired by Hollywood diva Audrey Hepburn and by the famous pin-up artist Alberto Vargas, who earned his glory thanks to his work for Playboy and Esquire magazines. This aircraft was built as B-24J-86-CF, s/n 44-44072 and was transferred to the RAF on September 15, 1944 in Dorval, Canada. Ten days later it landed at Karachi, India and served with No. 159 and 255 Squadrons. The artwork was painted on the nose during service with the latter unit. In the final days of WWII, KH 211 was transferred to No. 99 Squadron based in the Coco Islands.

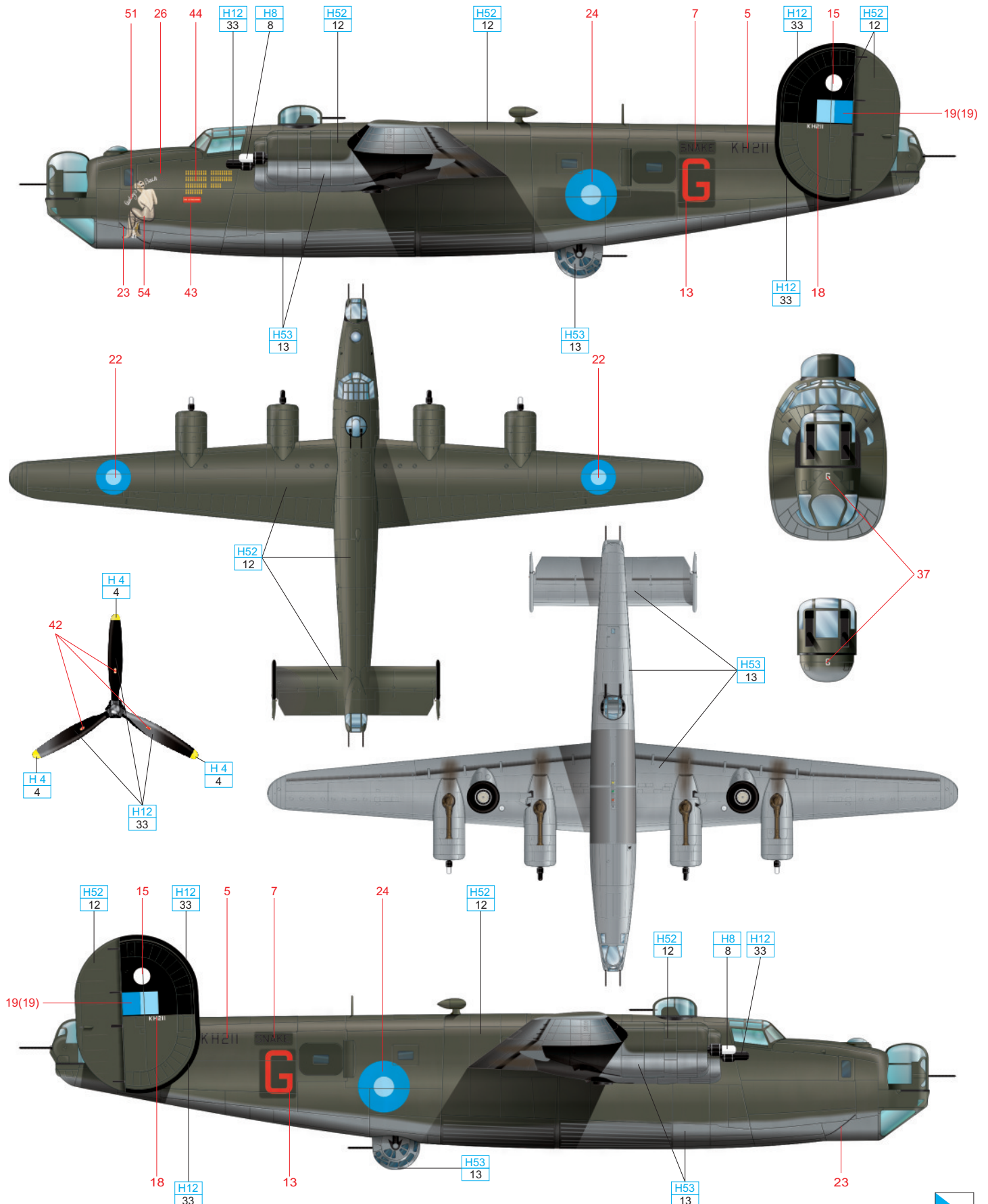

OLIVE DRAB H52
12 NEUTRAL GRAY H53
13 BLACK H12
33 SILVER H8
8 YELLOW H4
4

ČESKOU VERZI TEXTU NALEZNETE NA
www.eduard.com/info/photos/2110

B KH 283, captain S/L John Gauntlet, No. 159 Squadron RAF ACSEA, 1945

Former B-24J-90-CF, s/n 44-44154 was handed over to the RAF on October 11, 1944 in Dorset, Canada. As can be seen from the 'CF' code, the aircraft was built by the Fort Worth plant. The first operational mission was performed on January 8, 1945. It is known that this aircraft flew at least 17 combat missions, 15 of them with the crew of S/L John Gauntlet. The surfing girl pin-up was based on the artwork of the famous artist Alberto Vargas.

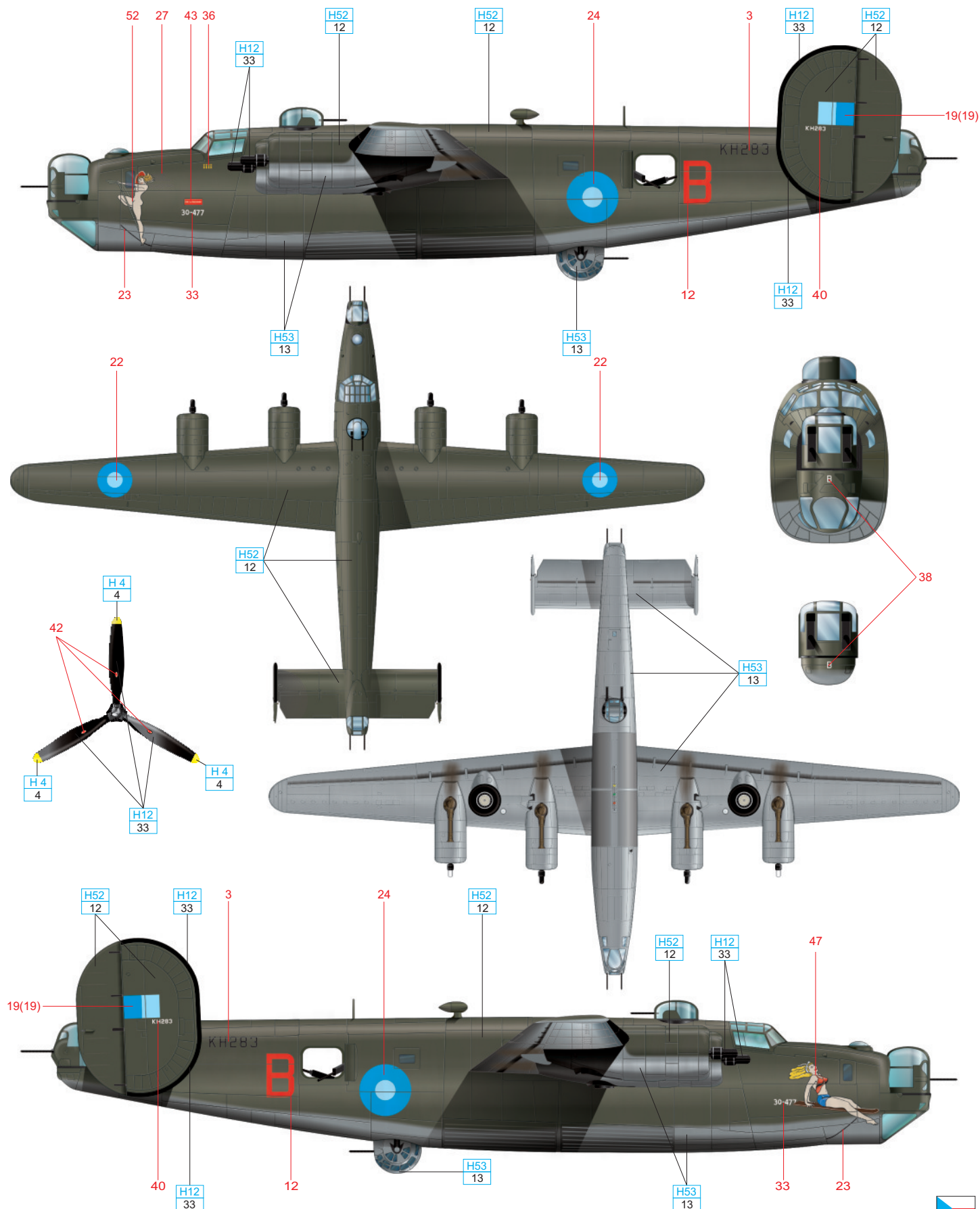

OLIVE DRAB	H52 12	NEUTRAL GRAY	H53 13	BLACK	H12 33	WHITE	H1 1	YELLOW	H4 4
------------	-----------	--------------	-----------	-------	-----------	-------	---------	--------	---------

ČESKOU VERZI TEXTU NALEZNETE NA
www.eduard.com/info/photos/2110

D KH 327, 'Y'vonne Yippee', No. 159 Squadron RAF ACSEA, 1945

'Y'vonne Yippee', formerly B-24J-91-CF, s/n 44-44198, was another Liberator B. VI flown by No. 159 Squadron. It performed at least 27 combat missions, mostly flown by crews captained by F/Lt. J. Hall and F/O R. W. Dick. In June 1945, the aircraft was transferred to No. 1348 (ASR) Flight.

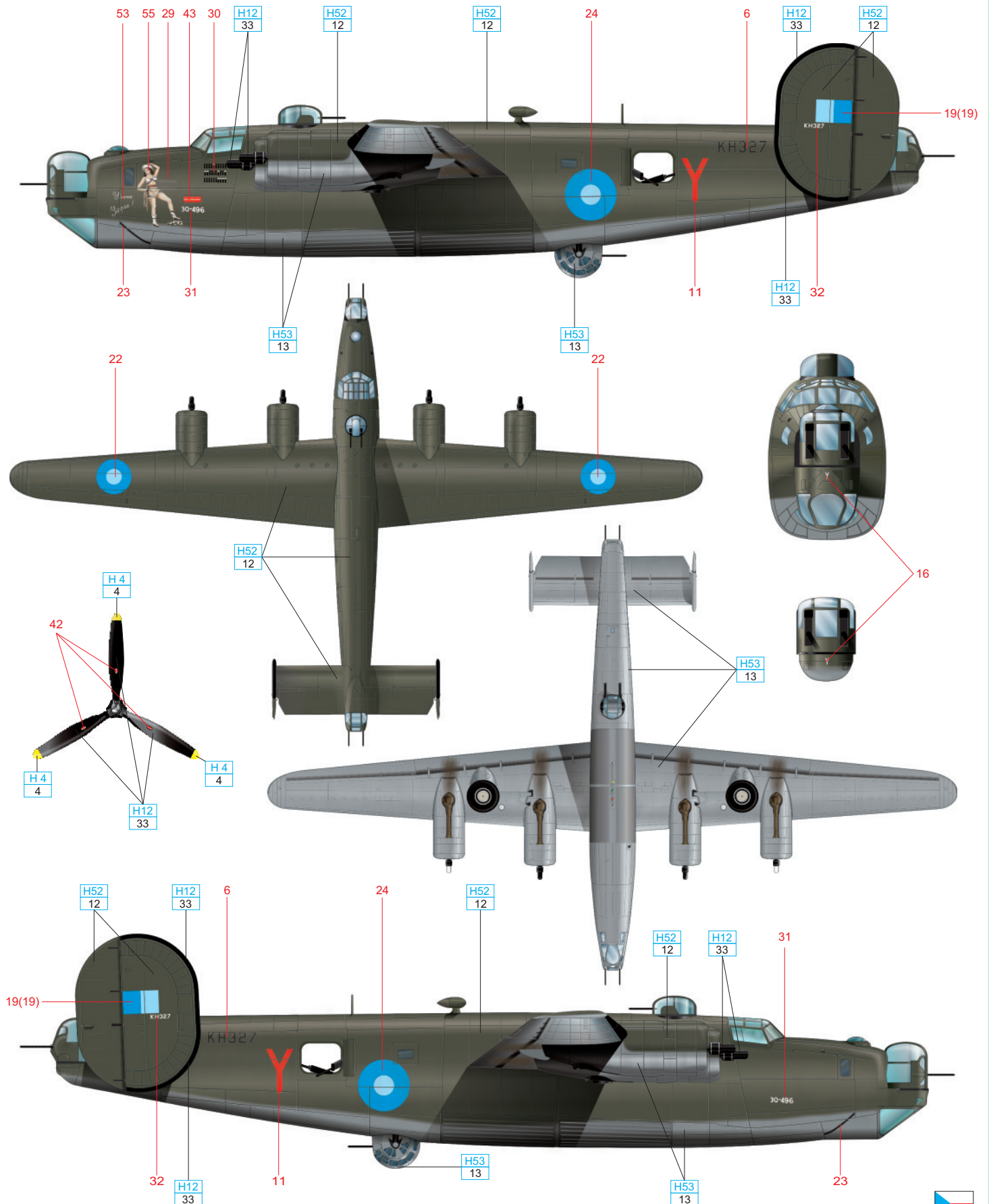

OLIVE DRAB	H52 12	NEUTRAL GRAY	H53 13	BLACK	H12 33	WHITE	H1 1	YELLOW	H4 4
------------	-----------	--------------	-----------	-------	-----------	-------	---------	--------	---------

ČESKOU VERZI TEXTU NALEZNETE NA
www.eduard.com/info/photos/2110

