

Me 262 B-1a / B-1a U1 and Avia CS-92

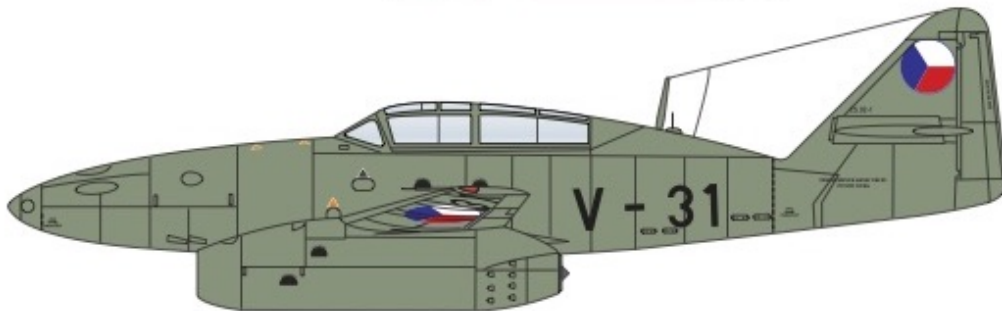

For the best results these decals should be applied to a gloss surface such as provided by either Xtracolor or Xtracrylix paints. Cut out the decal required and soak in warm water until the decal is released from the backing paper. Wet the area to be decaled with MICRO SET which will help to eliminate air trapped under the decal and position the decal.

After 5 or 10 minutes wet the decal with MICRO SOL which will soften the decal and ensure that it settles down over any surface detail. Allow the decal to dry for at least 12 hours. During this time some wrinkling of the decal may occur, this is normal. Do not touch the decal at this time.

Carefully check for small air bubbles and if there are any prick with a needle and apply a drop of MICRO SOL. After all air bubbles have been eliminated and the decals are dry wash the entire model with water to remove any excess decal adhesive.

When completely dry the whole model should be sprayed with a coat of Xtracolor or Xtracrylix with a coat of Flat, Satin or Gloss varnish depending on the finish required.

Store in a cool dry place, avoid sunlight, dampness or extremes of temperature and/or humidity.

Me 262 B-1a W.Nr 111643 B3+ZM of 4./KG (J) 54 found near village of Lužec nad Vltavou, Czechoslovakia on 4th May 1945. Aircraft is a perfect example of the late war situation with many unfinished sub-contracted parts used to a much needed Me 262 trainer in the air. Messerschmitt Me 262's of KG & KG(J) units p. 170-177, by Brown, Janda, Poruba & Vldar, JaPo 2010

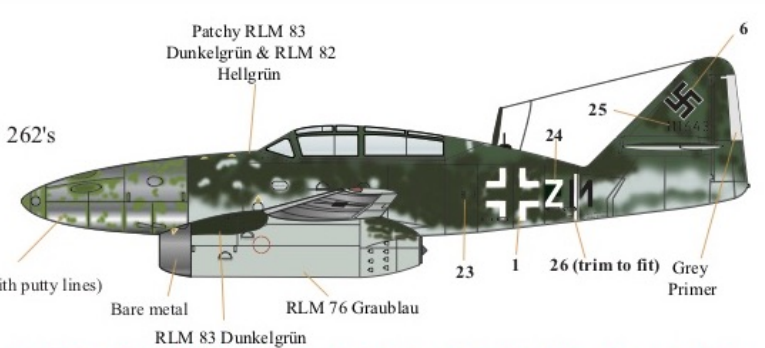
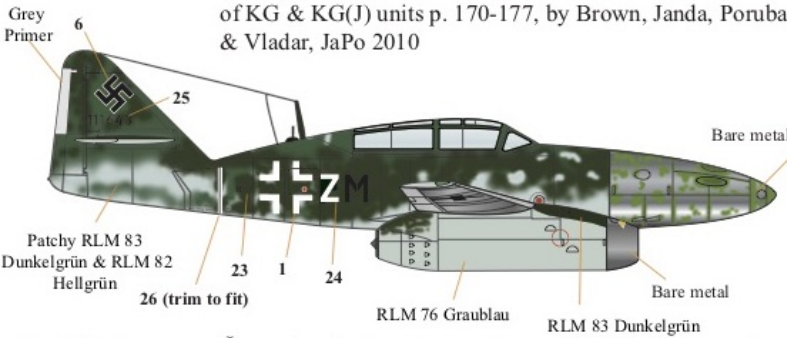

Modelling Note: The rear view of the deployed landing flaps shows that like the rudder trim and anti-stall slats, the righter outer landing flap is also in primer. Same view offers no evidence of splinter pattern on wings. Underneath the 'Z' there is a painted over 'P'

Me 262 B-1a seen at Žatec, Czechoslovakia in a disassembled condition without wings or top section of fin so use own judgment regarding wing and engine pod colours. Messerschmitt Me 262's of KG & KG(J) units p. 164-169, by Brown, Janda, Poruba & Vldar, JaPo 2010

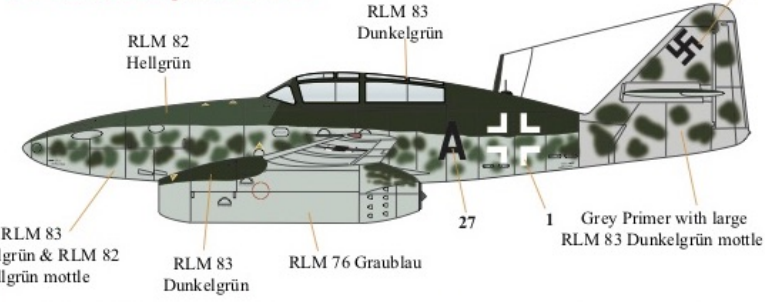
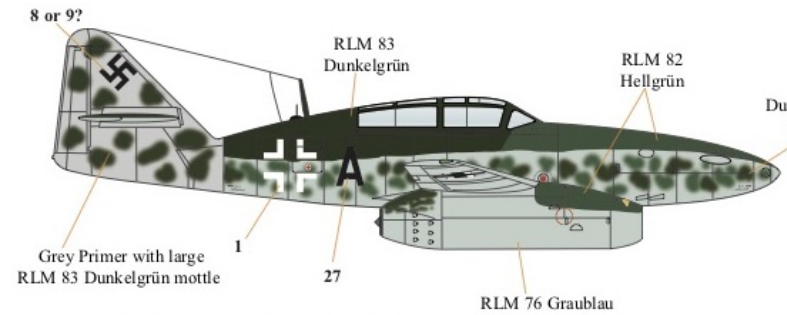

Modelling Note: A new tail section in the paler than RLM 76 primer has been added and then mottled over. The unfinished part may have had a simplified Swastika like decal 8 or 9?

Me 262 B-1a White S of III./EJG 2, Lechfeld 1944. Aircraft has a very clean look with minimal mottle and rare white Swastika backing only. Götterdämmerung, No.1, Classic, p.88. Messerschmitt Me 262's of KG & KG(J) units p. 165, by Brown, Janda, Poruba & Vldar, JaPo 2010

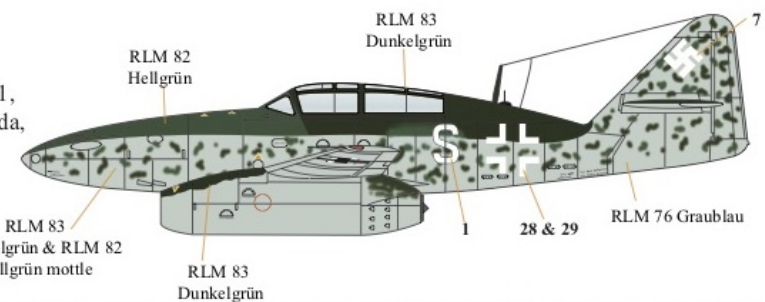
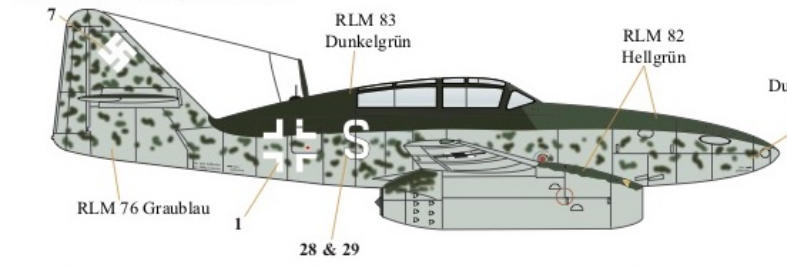

Modelling Note: Aircraft wears the simplified two sections of fuselage colour only but a part of the RLM 83 over-spray has been missed

Me 262 B-1a White 17 flown by Oberst Hans Trautloft of III./EJG 2 at Lechfeld, November 1944. Aircraft appears to be in the slightly more contrasting RLM 81/82 seen on many Me 262s at the time the RLM 04 Gelb fuselage band was used. Messerschmitt Me 262's of KG & KG(J) units p. 164-169, by Brown, Janda, Poruba & Vldar, JaPo 2010. Luftwaffe Ar War, Nightfighters Over The Reich, Griehl, p.69

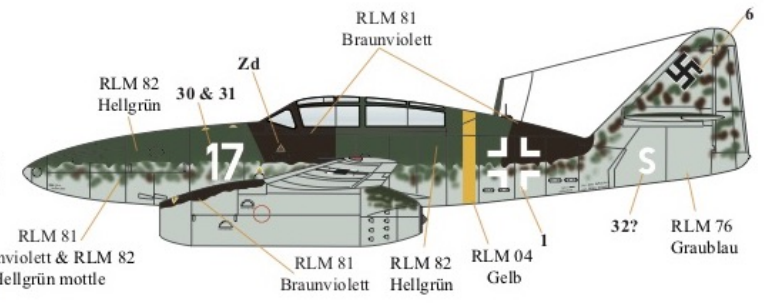
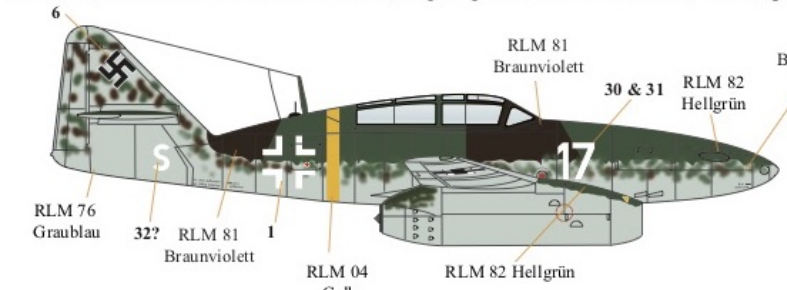

Modelling Note: The use of an 'S' to supplement the aircraft number would be normal but is out of sight in the three photos of this machine

Me 262 B-1a W.Nr 110639 possibly of NAGr 6. Surrendered at Lechfeld, May 1945. Aircraft now resides at NSA Willow Grove, USA. Aircraft appears to wear a much more complex RLM 82/83 splinter pattern on the fuselage but sadly all photos are contradictory due to light conditions. Marking '555' applied after capture. War Prizes, Phil butler, p.195, Luftwaffe Warbirds Photo Album, Vol 5, p.70.

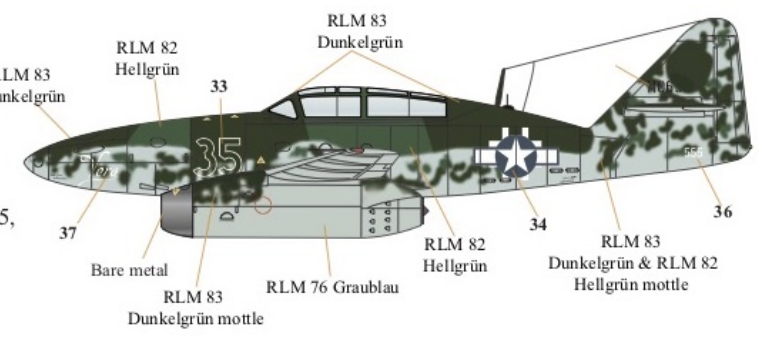
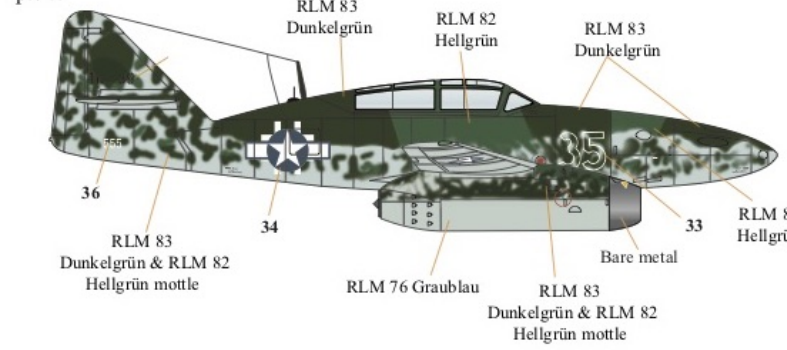

Modelling Note: Tail insignia over-spray has partially covered the W.Nr but decal is given in full in case of modelling subject in German markings Obviously without the name Vera!). Curiously no attempt was made to hide the remains of the original fuselage insignia so this has been provided as a unique decal

Me 262 B-1a/U1, W.Nr 110635 'Red 10' of IV./NJG 11 based at Schleswig where it was surrendered to the British. Aircraft has an RLM 76 upper base coat over an RLM 22 lower surface. The upper surface is finished with an RLM 83 mottle. War Prizes, Phil butler, p.191. Me 262 Volume Three by Smith & Creek, Classic Publications p. 462. Mosquitos uber Berlin, by Andreas Zapf VDM p. 515

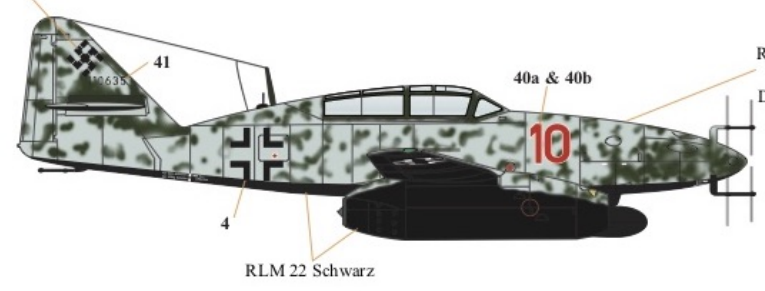
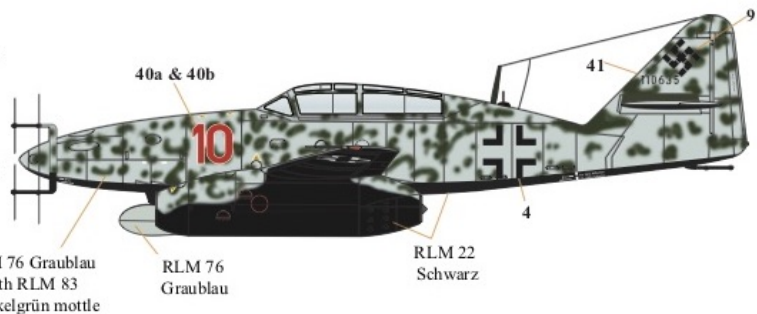

RLM 76 Graublau with RLM 83 Dunkelgrün mottle
RLM 76 Graublau
RLM 22 Schwarz

Modelling Note: Supposedly Kurt Welter flew Rote 10 but no logs exist

As above but in RAF insignia after surrender at Schleswig. War Prizes, Phil butler, p.191

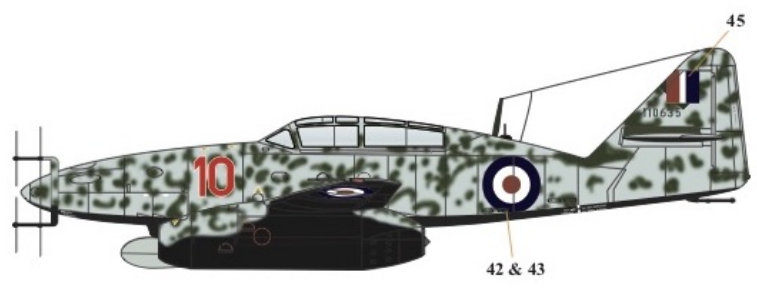

Me 262 B-1a/U1 W.Nr 110306 'Red 9' of IV./NJG 11 based at Schleswig where it was surrendered to the British and like Red 8 and Red 10 and 12 (Red 11 destroyed in RAF raid on the 13th April 1945) had RAF insignia applied. Aircraft has an RLM 76 upper base coat over an RLM 22 lower surface. The upper surface is finished with an RLM 82/83 mottle, the style of the application being different on each side. War Prizes, Phil butler, p.189, Nightfighters Over the Reich, Manfred Griehl, p.70. Me 262 Volume 4, Smith & Creek p. 845-847

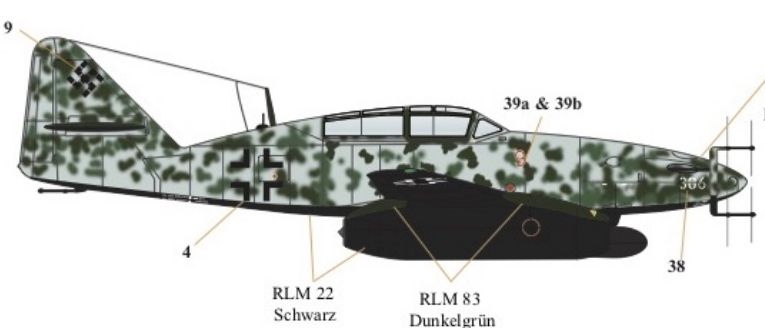
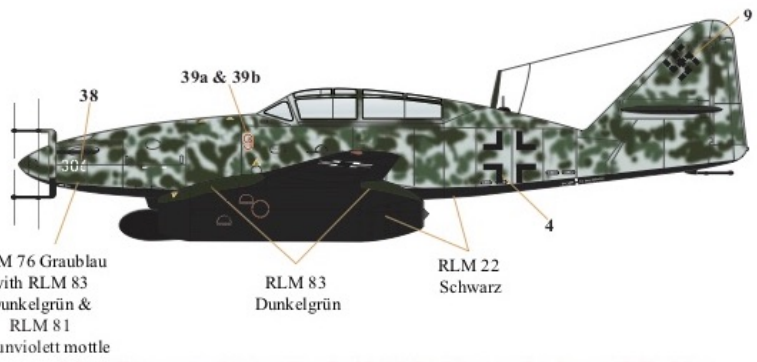

RLM 76 Graublau with RLM 83 Dunkelgrün & RLM 81 Braunviolett mottle
RLM 83 Dunkelgrün
RLM 22 Schwarz

Modelling note: Using decals 42/43 Red 9 can also be modelled in RAF markings as per Red 10 with W.Nr 306 on the nose remaining. Log books show Herbert Altner and Georg Czypionka both having flown Rote 9

After wearing its RAF roundels Red 9 was handed over to Col Watson on the 19th June and flown to Melon-Villaroche where it was marked '999' as well as adorning the Watson Whizzer's motif and name 'Old Fruit Cake.' War Prizes, Phil butler, p.197

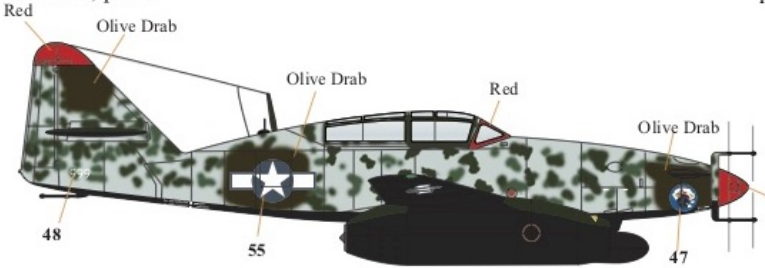

Modelling note: Olive Drab over-painting of the RAF markings may well be locally obtained new RLM 83 but it does appear much darker in black and white photos.

Avia CS-92.3 V-31 of the VLÚ Scientific Aviation Insitute, September 1947. Aircraft is painted in a locally mixed paint similar to the German RLM 02 Grau. Me 262, MBI, p.53

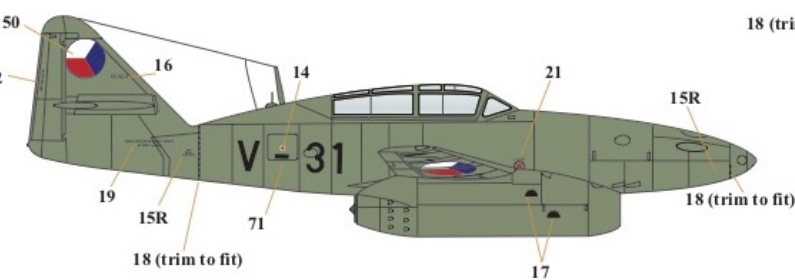
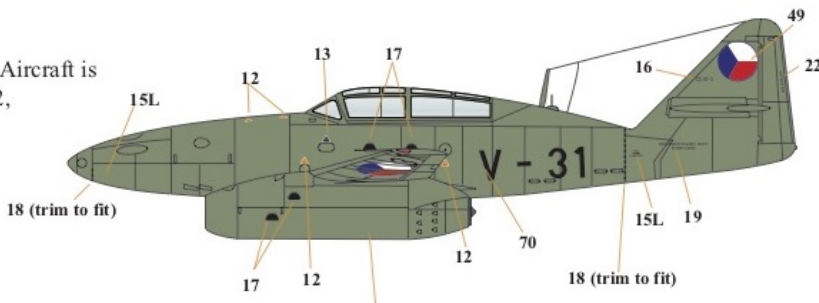

Modelling note: Locally Mixed paint for Avia Company similar in shade to Humbrol 31

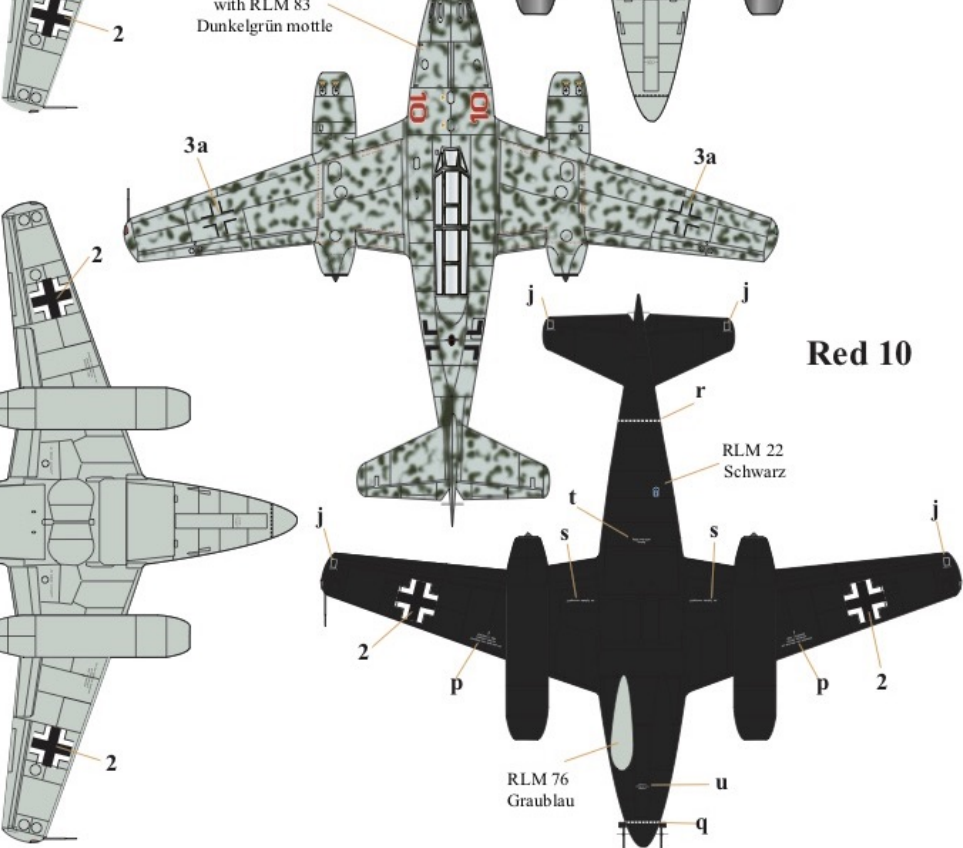
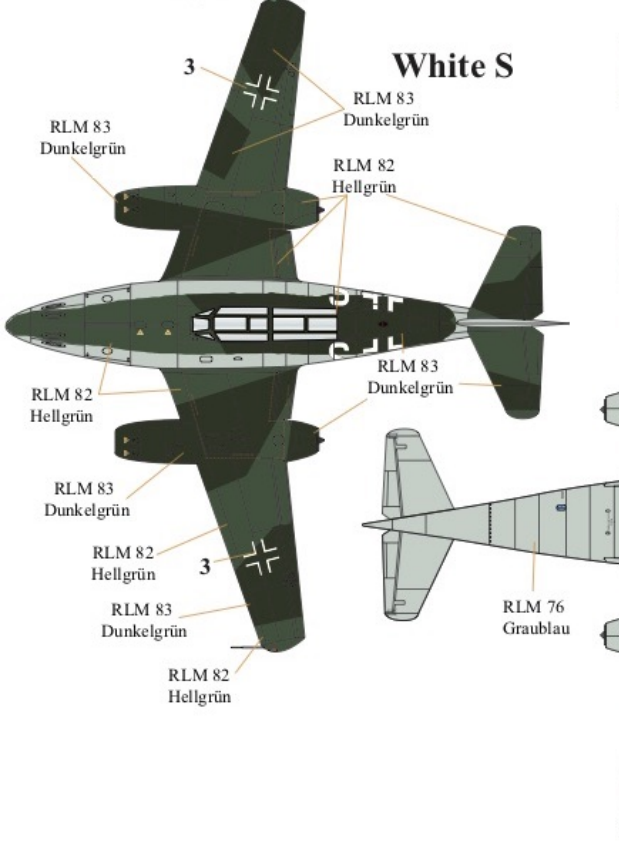
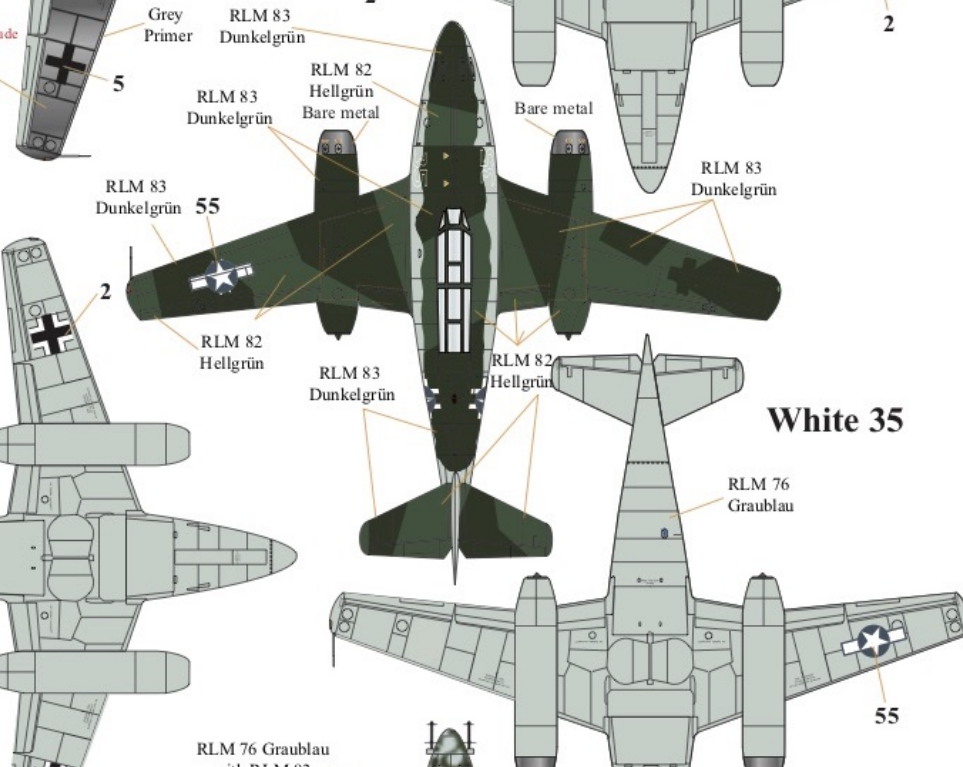
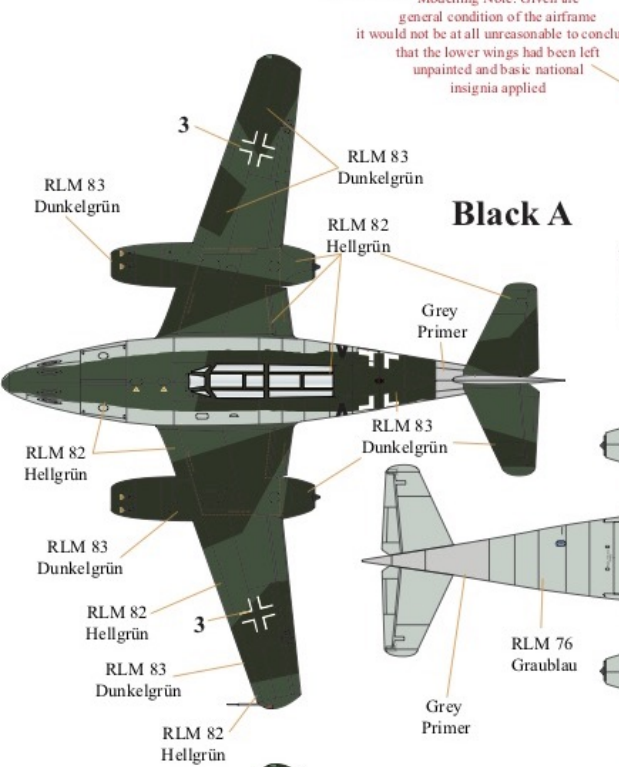
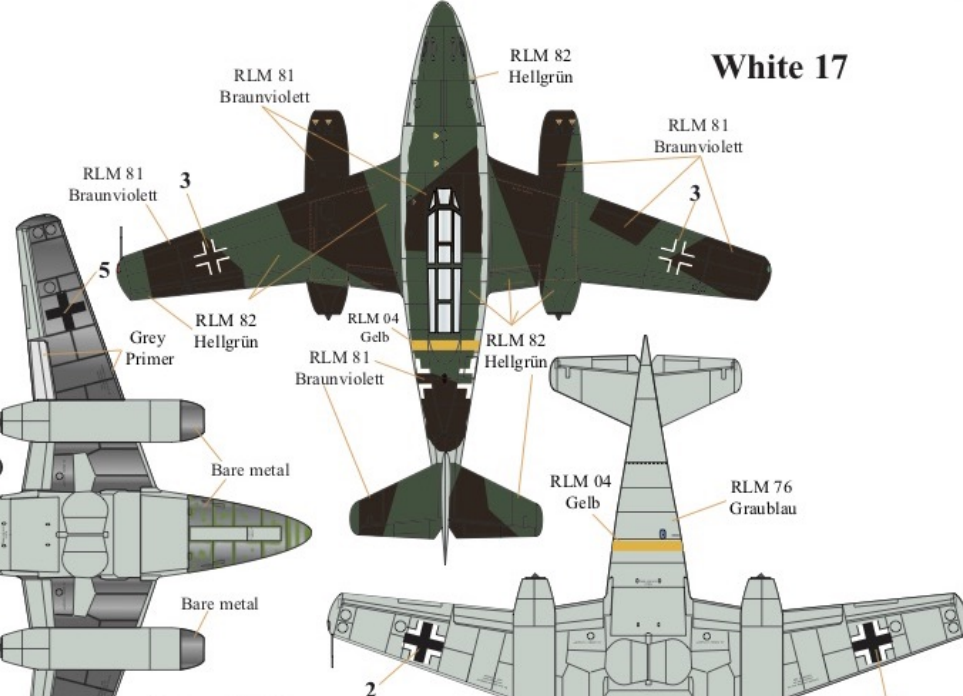

Modelling Note: Given the general condition of the airframe it would not be at all unreasonable to conclude that the lower wings had been left unpainted and basic national insignia applied

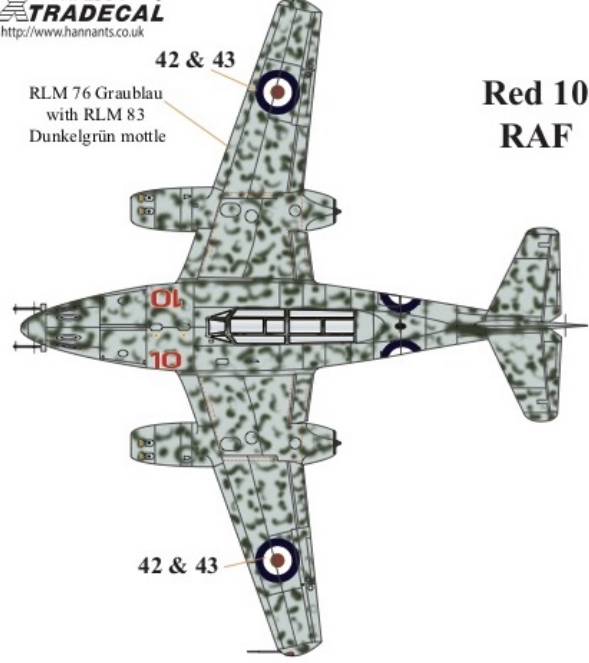

**Red 10
 RAF**

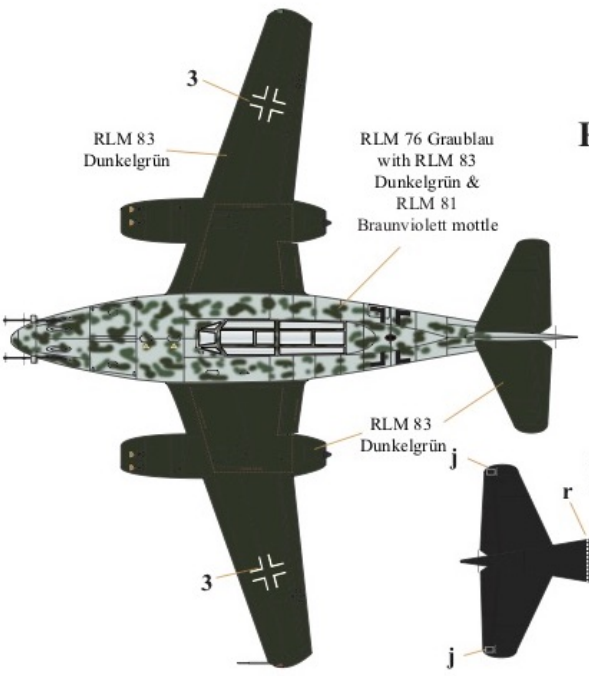
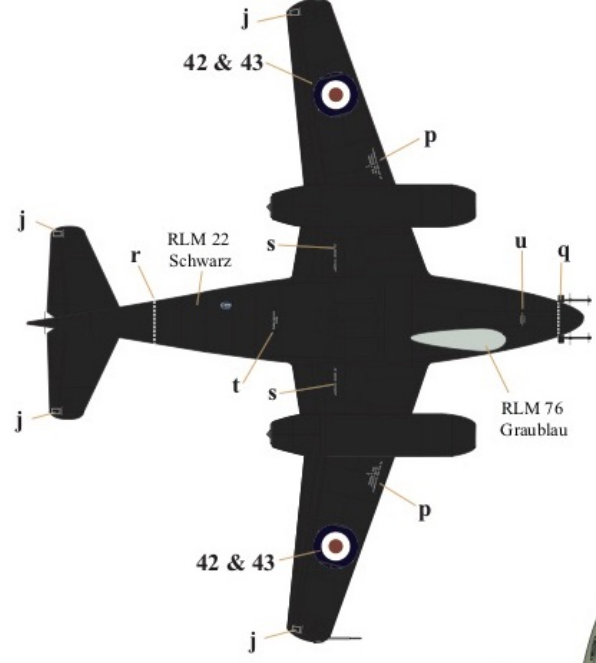

Red 9

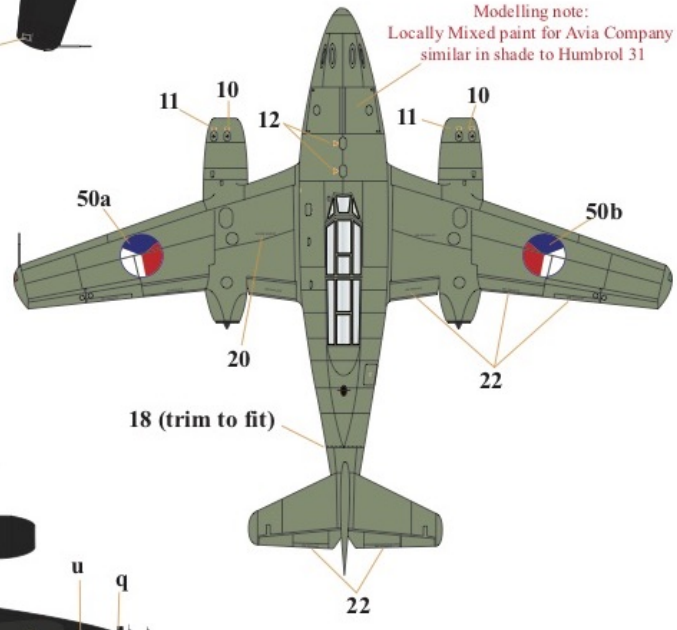
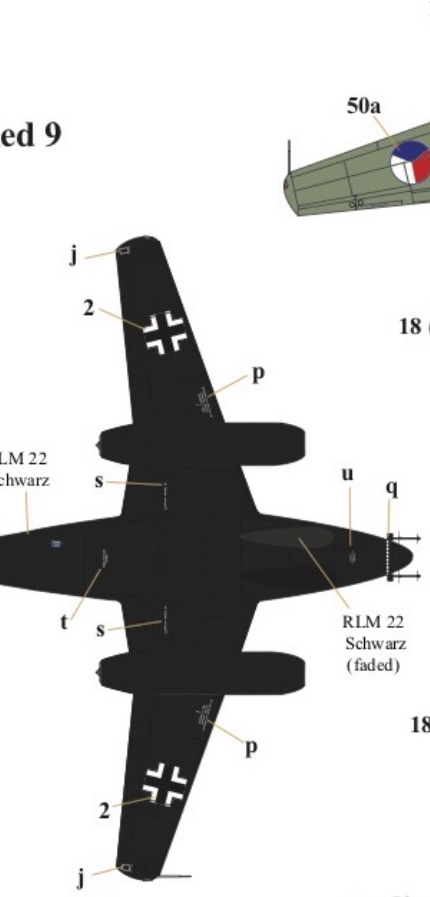

V-31

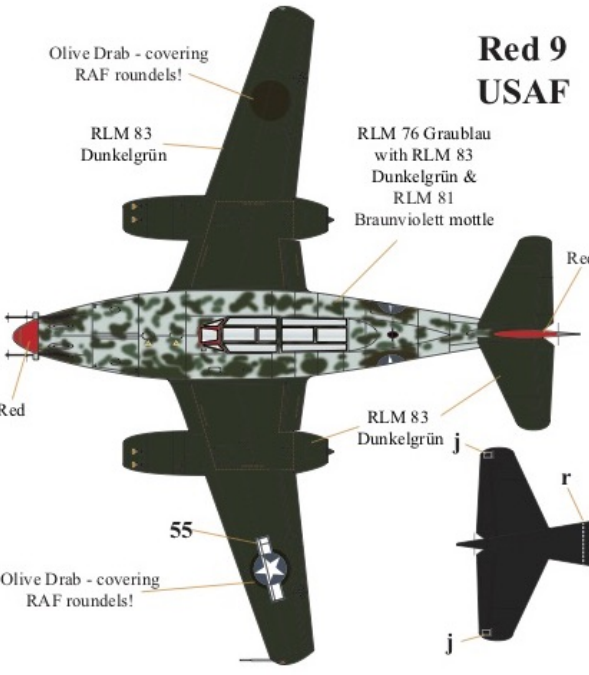

**Red 9
 USAF**

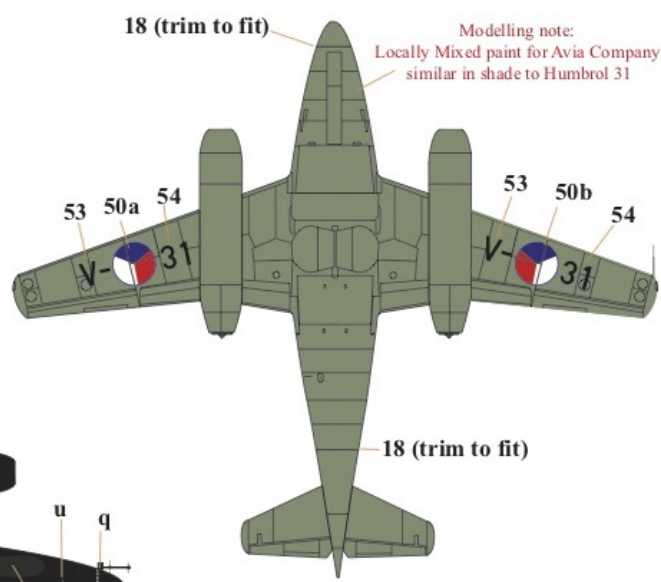
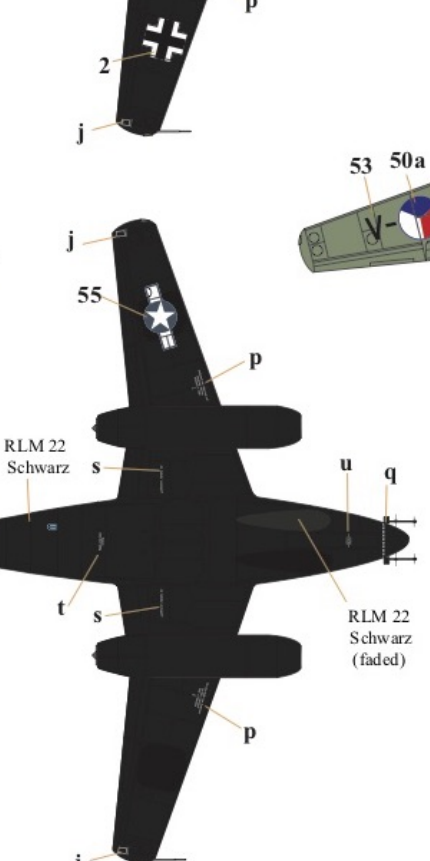

Stencils for Me 262 B-1a

zd - White 17 only!

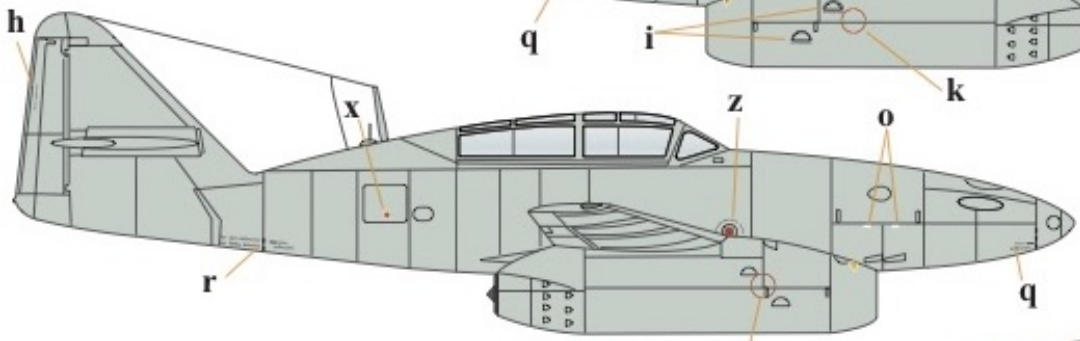

• Achtung! • Rad nicht teilen bevor Reifen luftleer •

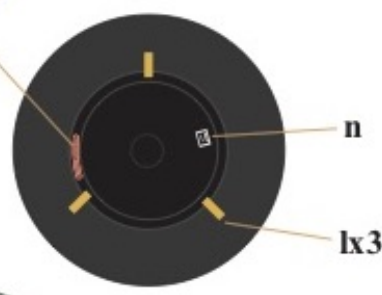
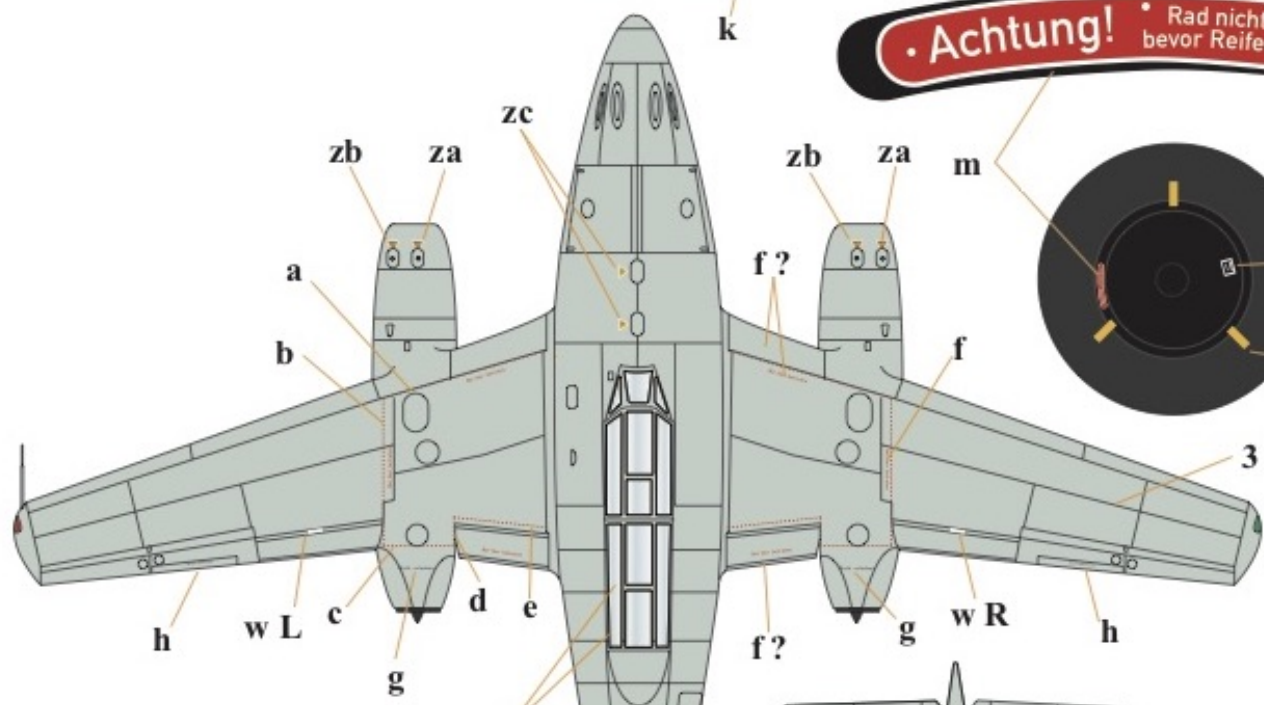

Nur hier betreten

Nur hier betreten

Sometimes found on inner landing flap and inner anti-stall flap

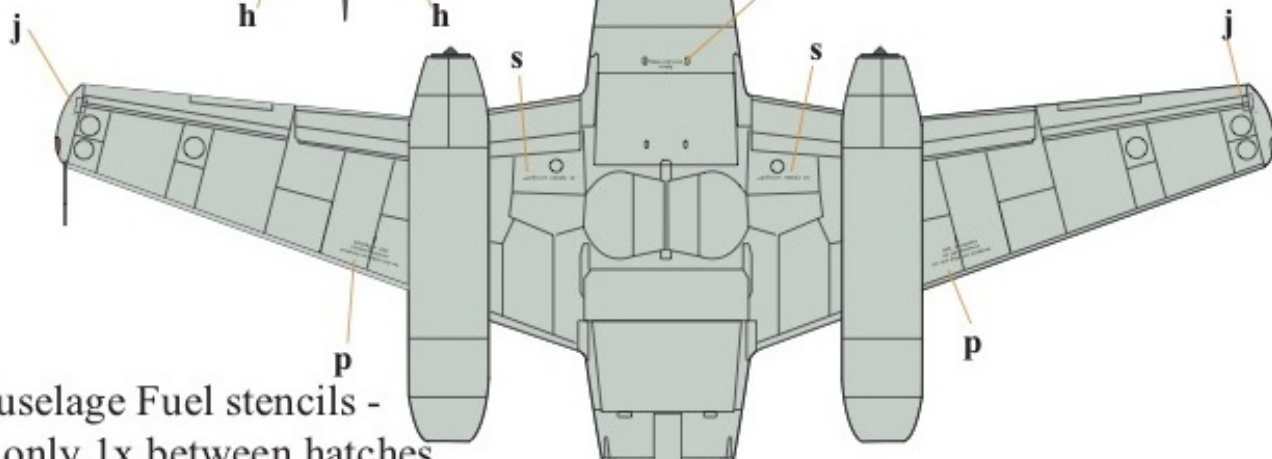
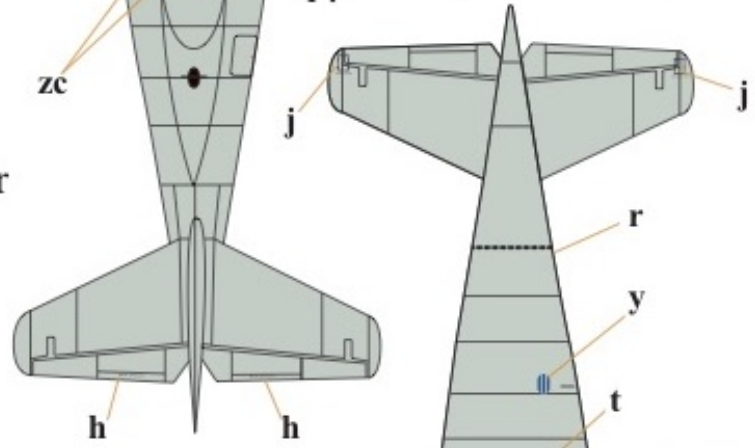

Upper Fuselage Fuel stencils - Sometimes only 1x between hatches

Nur hier betreten

Nur hier betreten



Upper wing walkway - Both colours used, 'White 17' has red