

LUFTWAFFE WWII NIGHT FIGHTER 1:48 SCALE PLASTIC KIT



eduard

intro

ProfiPACK



The second half of the Second World War saw the Focke-Wulf Fw190, in its various forms, emerge as the best of what was available to the Luftwaffe. The dedicated fighter version was a high performance, heavily armed machine. Its development had a precarious beginning, against a 1938 specification issued by the Technisches Amt, RLM. The first prototype took to the air on June 1, 1939. After a series of improvements and even radical changes, the design culminated in the fall of 1940 in the pre-series version Fw190A-0 to the tune of twenty-eight pieces. Six of these were retained by the test unit Erprobungsstaffel 190 at Rechlin, which was tasked with conducting service trials. These revealed a wide range of flaws to the point where the RLM halted further development. Despite this, on the basis of urgings from the test unit staff, the aircraft was not shelved. After a series of some fifty modifications, the RLM gave the go ahead for the Fw190 to be taken into inventory of the Luftwaffe. In June, 1941, the Luftwaffe accepted the first of 100 ordered Fw190A-1s, armed with four 7.9mm MG17s. By September, 1941, II/JG 26 was completely equipped with the type, operating on the Western Front. November saw the production of the next version Fw190A-2, powered by a BMW801C-2, and armed with two 7.9mm MG17s and two MG151s of 20mm caliber in the wings. Part of this series received an additional pair of 20mm MG FFs, thus attaining an armament standard of later types. A significant advancement to the design came in the spring of 1942, when the BMW801D-2 became available, whose installation gave birth to the Fw190A-3. July saw the development of the improved A-4. Both were armed with what became the standard two fuselage mounted MG17s, two wing mounted MG151 cannon, and two MG FF cannon, placed inboard of the wheel wells. During 1942, production had intensified, and a production facility was set up under license at Fieseler. Thanks in part to this, production rose in 1942 to 1,878 units as opposed to 224 in 1941. Large-scale production of the A-5 was initiated in April, 1943, with an identical wing to the A-4, but with a nose extension that would become standard on all subsequent Fw-190A versions up to the A-9, and also on the corresponding F types. July saw the development of a new, strengthened wing, which incorporated MG151s instead of the MG FFs in the outer position. The adoption of this wing developed the A-6 version. Further changes developed the A-7, produced during the end of 1943. This version came about with the replacement of the fuselage mounted MG17s with 13mm MG131s. Further improvements led to the Fw190A-8, and this version became the most widely produced with some 1400 units made. The most significant change to this variant was the installation of the GM-1 nitrous-oxide injection system, for temporary power boost in combat. A portion of A-8 production was built as the A-8/R2 and A-8/R8, armed with MK108 cannon in the outer wing location, and with armoured slabs added to the cockpit sides and a modified canopy. The final production version of the BMW801 powered fighter was the Fw190A-9, equipped with the BMW801TS of 2000hp (1470kW). There was a parallel development of these fighter optimized aircraft with a dedicated fighter-bomber version, the Fw190F. These aircraft had reduced wing armament to two MG151 cannon in the wingroot position. The engine was optimized for low level operation, and the armament options varied to satisfy the ground attack role, including bombs of various weight classes and a variety of anti-tank rockets. This branched into the extended range Fw190G version. Development of the thoroughbred fighter continued in the guise of the Fw190D, which began to reach Luftwaffe units in the second half of 1944, and was the result of mounting an in-line Jumo213A-1 engine into a modified Fw190A-8 airframe. Although the Fw190 never achieved the widespread usage of the competing Bf109, its contribution to the German Air Force was certainly significant through the second half of WWII. Fw190s saw service on the Western Front as well as in the East. As heavy fighters with imposing firepower, they found themselves integral components, from 1943 onwards, within the units tasked with the protection of the Reich from the ominous clouds of allied four-engined bombers. This is where the A-8 version was instrumental, along with its A-8/R2 armoured development. This version, with its firepower, was a very ominous and daunting foe for the bomber crews. From the second half of 1944, their danger was kept in check to a degree by escorting P-47s, and necessitated the development of the P-51 Mustang.

úvodem

Ve druhé polovině 2. světové války patřil Focke-Wulf Fw 190 různých verzí k tomu nejlepšímu, čím Luftwaffe disponovala. Stíhací verze Fw 190 představovaly výkonný, těžce vyzbrojený stroj. Jeho nesnadný vývoj začal v roce 1938 na základě specifikací Technisches Amtu RLM. První prototyp poprvé vzletěl 1. června 1939. Po řadě změn a mnohdy radikálních úprav se vývoj na podzim roku 1940 dopracoval k předseriové verzi Fw 190 A-0, vyrobené ve 28 kusech. Šest těchto strojů obdržela na jaře 1941 zkušební jednotka Erprobungsstaffel 190 na letišti v Rechlinu, která s nimi prováděla provozní zkoušky. Ty odhalily takové množství nedostatků, že RLM téměř zastavil další vývoj. Nicméně, na doporučení personálu zkušební jednotky dostal stroj šanci. Po provedení více než 50 změn na draku letounu vydalo RLM povolení k zařazení Fw 190 do řadové služby v Luftwaffe. V červnu 1941 převzala Luftwaffe první za sta objednaných sériových Fw 190 A-1, vyzbrojených čtyřmi kulomety MG 17 ráže 7,9 mm. V září 1941 jimi byla vyzbrojena celá II/JG 26 na západní frontě. V listopadu pak začala výroba další verze, Fw 190A-2, poháněné motorem BMW 801C-2 a vyzbrojené dvěma kulomety MG 17 a dvěma kanóny MG 151 ráže 20 mm v křídlech. Část této série měla také přídavné kanóny MG FF ráže 20 mm, čímž se výzbroj dostávala na pozdější vysoký standard. K významné změně došlo na jaře 1942, kdy byl k dispozici motor BMW 801 D-2, jehož montáž dala vzniknout verzi A-3. V červenci pak výroba plynule přešla na zlepšenou verzi A-4. Obě už byly standardně vyzbrojeny dvěma trupovými kulomety MG 17, dvěma křídelnými kanóny MG 151 a dvěma kanóny MG FF, montovanými rovněž do křídla vně podvozkových šachet. V roce 1942 už výroba nabíhala do vysokých obrátek, rozjela se rovněž licenční stavba Fw 190 u firmy Fieseler. I díky tomu dosáhla celková produkce roku 1942 1 878 strojů, oproti 224 kusům vyrobených v roce 1941. V dubnu 1943 výroba přešla na velkosériovou verzi A-5, s identickým křídlem jako u verze A-4, ale s prodlouženým trupem, který se stal nadále základní součástí draku všech pozdějších verzí až po A-9, včetně bitevních verzí Fw 190 F. V červenci bylo k dispozici nové, zesílené křídlo, v němž byly na vnější pozici instalovány kulomety MG 151 místo MG FF. Instalace tohoto křídla přinesla verzi A-6. Další změnou na výrobních linkách byla verze A-7, vyráběná na konci roku 1943. Vznikla nahrazením trupových kulometů MG 17 kulomety MG 131 ráže 13 mm. V únoru 1944 pak další úpravy vedly k verzi A-8, která se stala nejrozšířenější verzí tohoto letounu s bezmála 1400 vyrobenými stroji. Nejpodstatnější změnou byla instalace zařízení GM-1, krátkodobě zvyšujícího výkon motoru vstříkáním oxidu dusného do motoru. Část produkce verze A-8 byla vyrobena ve variantě A-8/R2 a A-8/R8, vybavené kanóny MK 108 na vnějších pozicích křídla, a přídavným pancéřováním pilotního prostoru a překrytu kabiny. Poslední sériově vyráběnou stíhací verzí s motorem BMW 801 byla v roce 1945 verze A-9, vybavená motorem BMW 801 TS o výkonu 2000 k (1470 kW). Paralelně s vývojem stíhacích verzí probíhal vývoj bitevních verzí Fw 190 F. Tyto stroje měly křídelní výzbroj redukovánou na dva kanóny MG 151 na vnitřních pozicích. Výkon motoru byl optimalizován pro operace v nižších letových hladinách. Stroje disponovaly velkou škálou podvěšené výzbroje pro pozemní útoky, zahrnující bomby různých ráží a řadu variant protitankových raket. Vzniklo rovněž několik variant verze G, což byl stíhací bombardér s prodlouženým doletem. Vývoj čistě stíhacích verzí pokračoval verzí Fw 190D, dodávanou jednotkám Luftwaffe od srpna 1944. Fw 190D vznikl instalací motoru Jumo 213 A-1 do upraveného draku Fw 190A-8. Ačkoli Fw 190 nikdy nedosáhl u stíhacích jednotek Luftwaffe tak velkého rozšíření jako konkurenční Bf 109, stal se významnou součástí válečného úsilí německého letectva ve druhé polovině 2. světové války. Fw 190 bojovaly jak na západní, tak na východní frontě. Jako těžké stíhací stroje s impozantní výzbrojí získávaly od roku 1943 na významu v jednotkách protivzdušné obrany Říše, kde se uplatnily v boji proti těžkým čtyřmotorovým bombardérům. V této roli byla významná především verze A-8 a její pancéřovaná varianta A-8/R2. Tyto stroje s jejich zesílenou výzbrojí byly pro spojenecké bombardéry skutečně vřezané. Od druhé poloviny roku 1944 ovšem jejich hrozbu stále úspěšněji eliminovaly doprovodné stíhačky P-47D a především vynikající P-51D Mustang.

ATTENTION



UPOZORNĚNÍ



ACHTUNG



ATTENTION



注意



Carefully read instruction sheet before assembling. When you use glue or paint, do not use near open flame and use in well ventilated room. Keep out of reach of small children. Children must not be allowed to suck any part, or pull vinyl bag over the head.



Před započítím stavby si pečlivě prostudujte stavební návod. Při používání barev a lepidel pracujte v dobře větrané místnosti. Lepidla ani barvy nepoužívejte v blízkosti otevřeného ohně. Model není určen malým dětem, mohlo by dojít k požití drobných dílů.

INSTRUCTION SIGNS



INSTR. SYMBOLS



INSTRUKTION SINNBILDEN



SYMBOLES

記号の説明

OPTIONAL
VOLBABEND
OHNOUTOPEN HOLE
VYVRTAT OTVORSYMMETRICAL ASSEMBLY
SYMETRICKÁ MONTÁŽREMOVE
ODŘÍZNOUTREVERSE SIDE
OTOČITAPPLY EDUARD MASK
AND PAINT
POUŽÍT EDUARD MASK
NABARVIT

PARTS



DÍLY



TEILE



PIÈCES



部品

PLASTIC PARTS

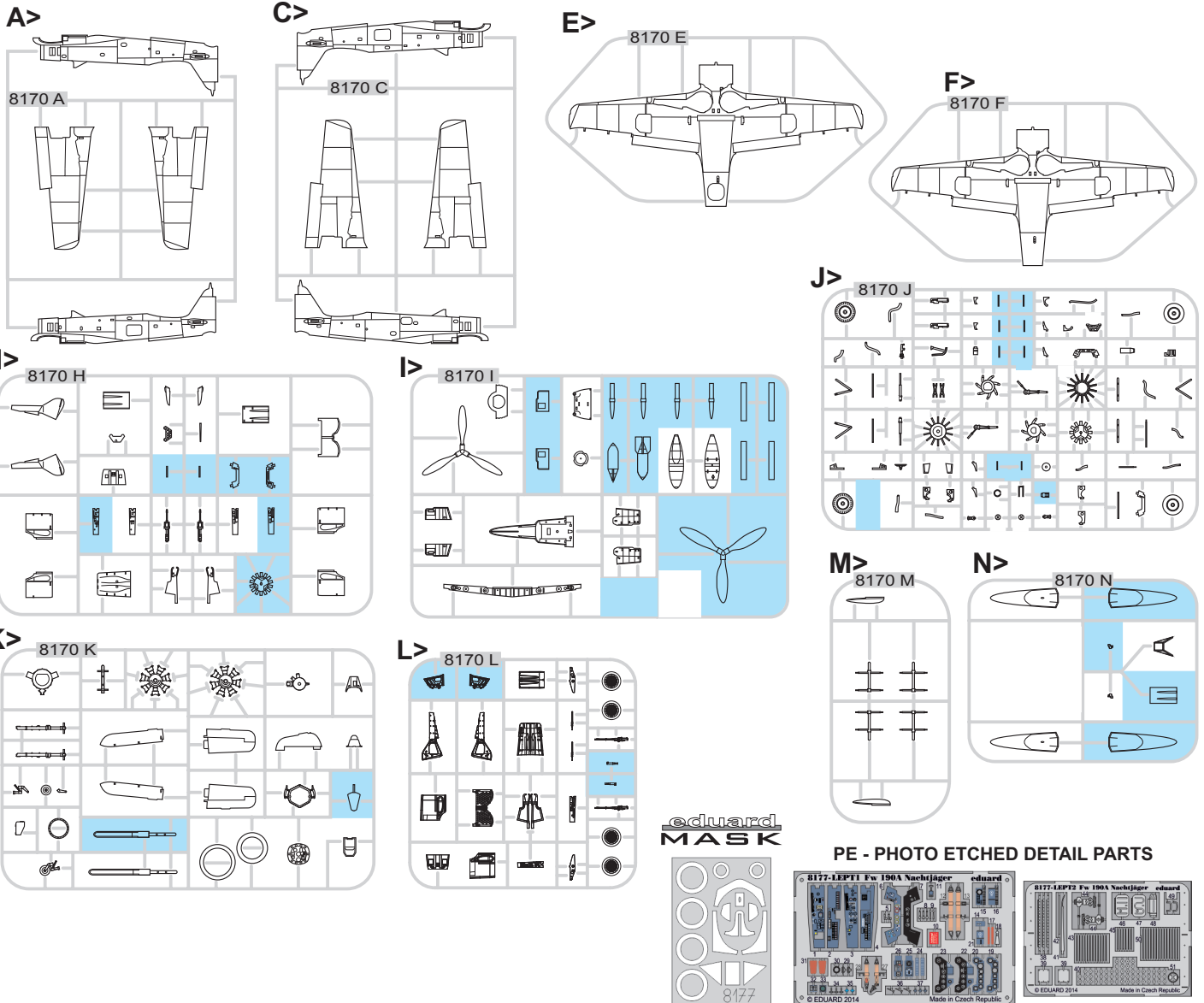

-Parts not for use. -Teile werden nicht verwendet. -Pièces à ne pas utiliser. -Tyto díly nepoužívejte při stavbě. - 使用しない部品

COLOURS



BARVY



FARBEN



PEINTURE



色

GSI Creos (GUNZE)		
AQUEOUS	Mr.COLOR	
H 1	C001	WHITE
H 2	C002	BLACK
H 3	C003	RED
H 4	C004	YELLOW
H 6	C006	GREEN
H 12	C018	FLAT BLACK
H 13	C003	RED
H 47	C041	RED BROWN
H 65	C018	RLM70 BLACK GREEN
H 68	C036	RLM74 DARK GRAY
H 69	C037	RLM75 GRAY

AQUEOUS	Mr.COLOR	
H 70	C060	RLM02 GRAY
H 77	C137	TIRE BLACK
H 344		RUST
H 417	C116	RLM66 BLACK GRAY
	C117	RLM76 LIGHT BLUE
Mr.METAL COLOR		
	MC214	DARK IRON
	MC218	ALUMINIUM
	MC213	STEEL
Mr.COLOR SUPER METALLIC		
	SM01	SUPER CHROME

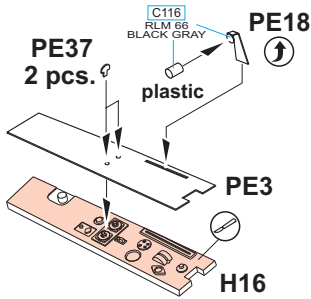

MARKINGS **A, D**

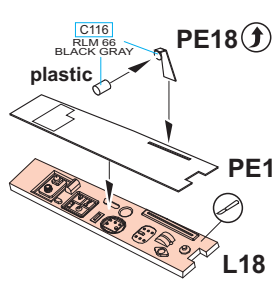

MARKINGS **B, C**

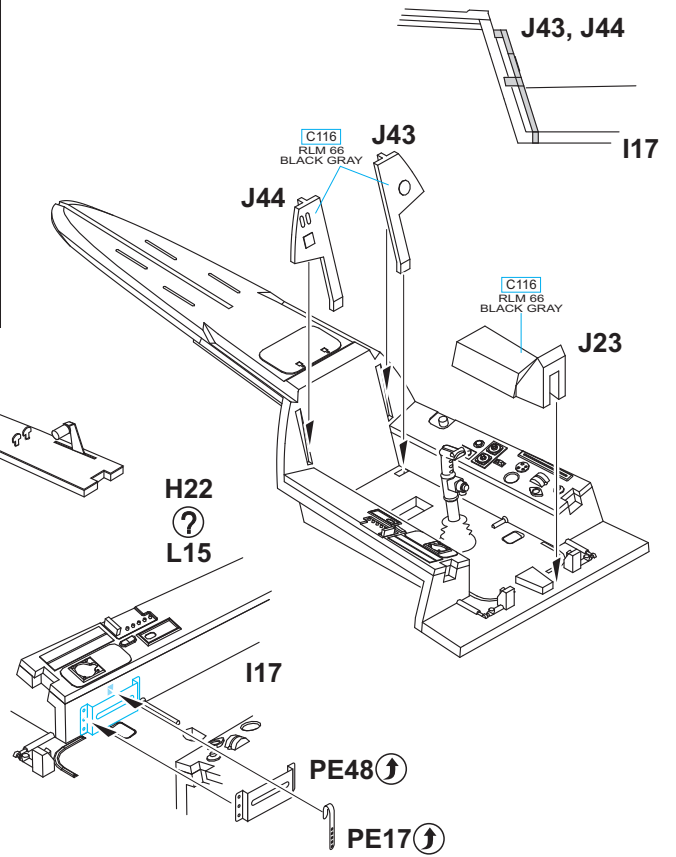

PE46 - MARKING **A** ONLY

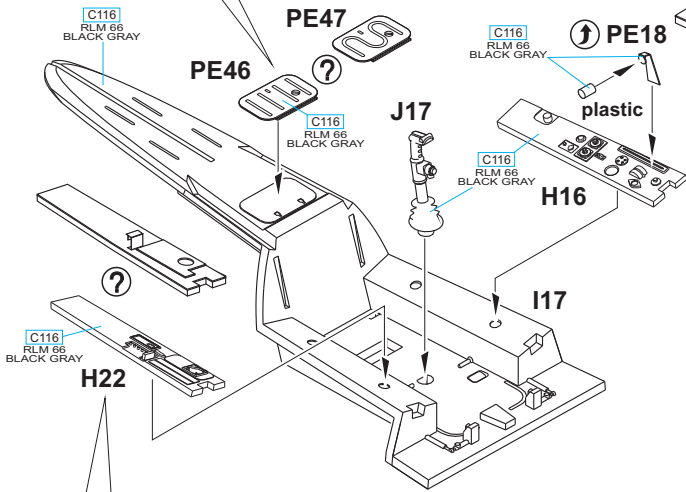

MARKINGS **A, D**

MARKINGS **B, C**

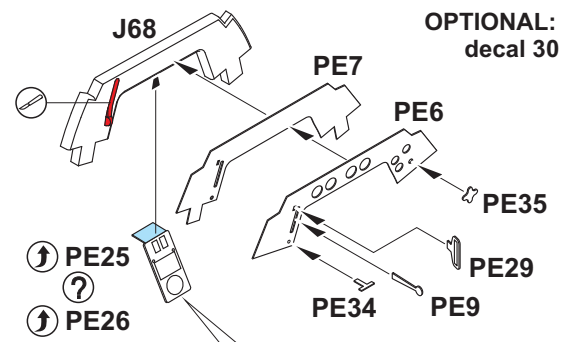
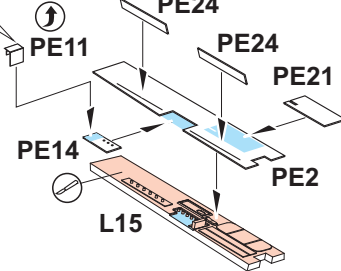
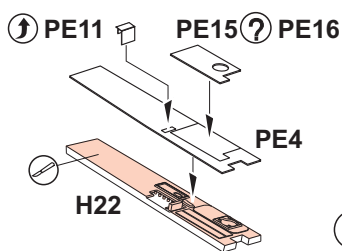

OPTIONAL:
decal 30

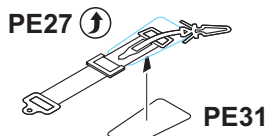
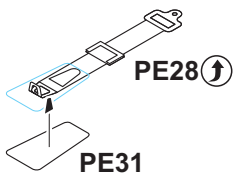

PE26 - MARKINGS **A, D**
PE25 ? PE26 - MARKINGS **B, C**

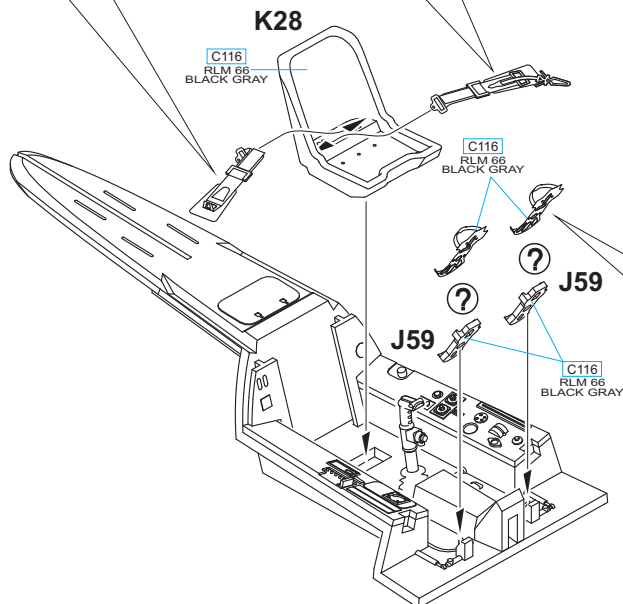
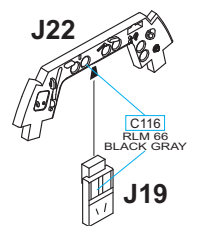

2 pcs.
PE44

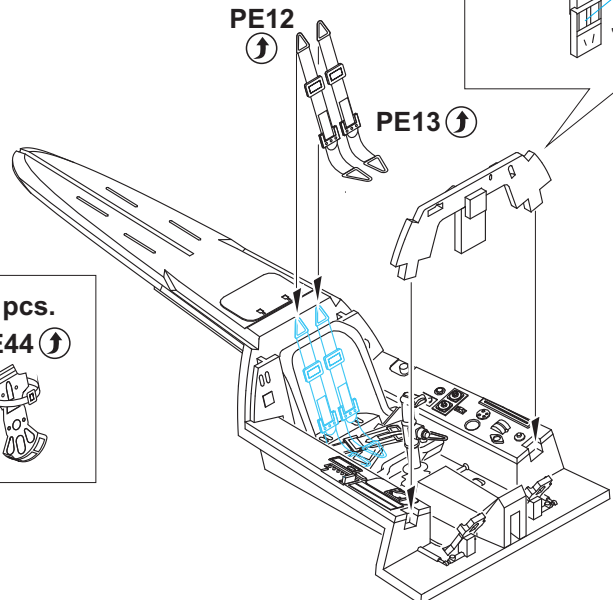

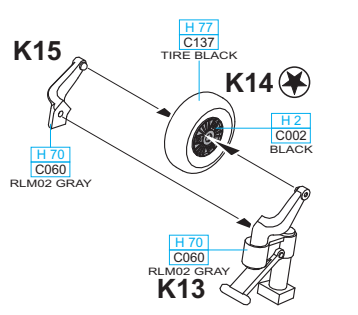
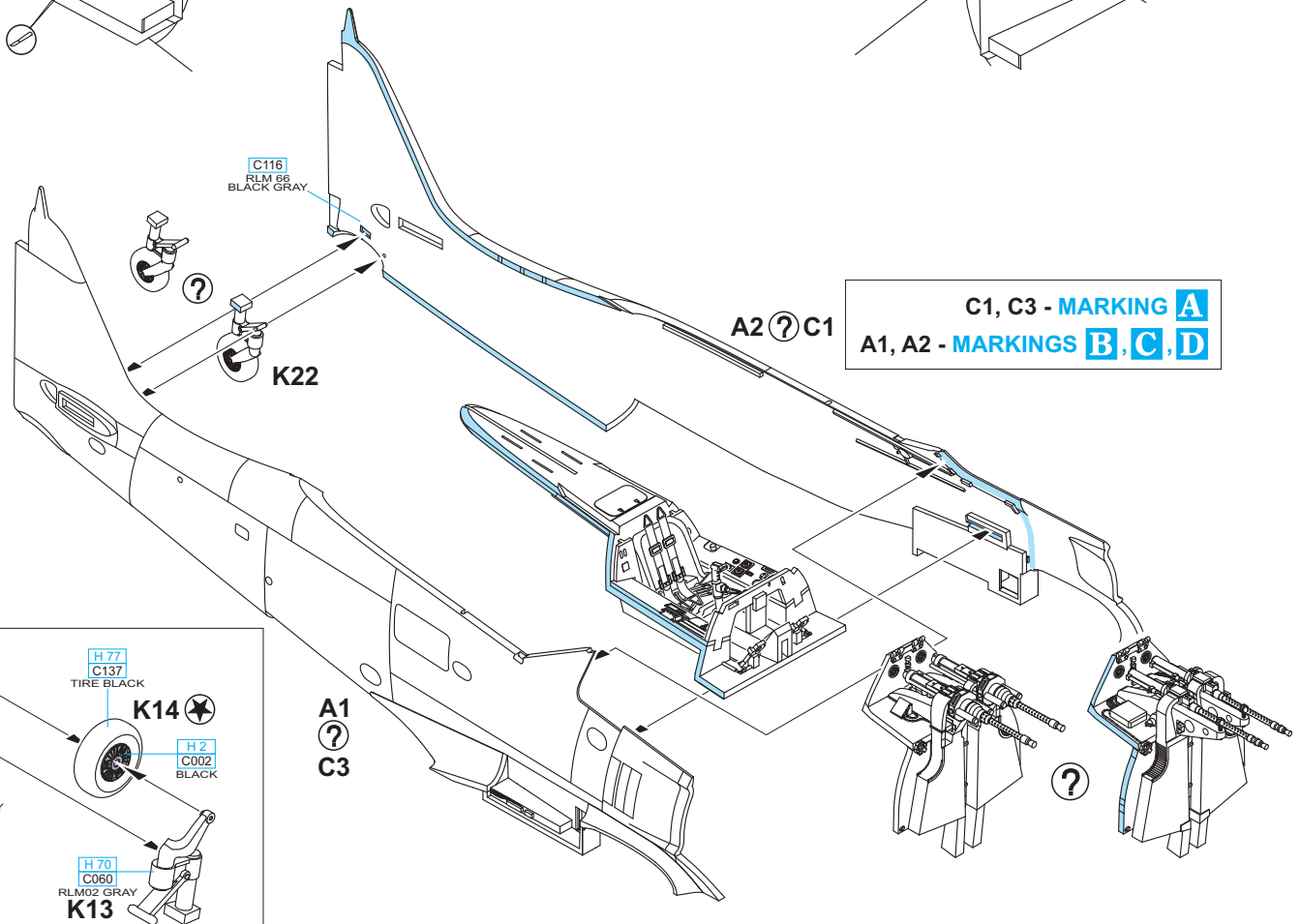
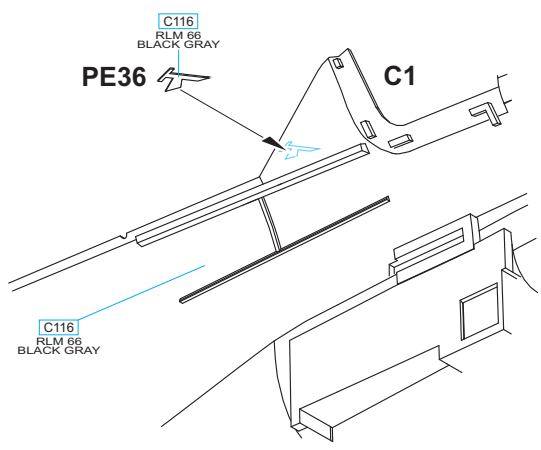
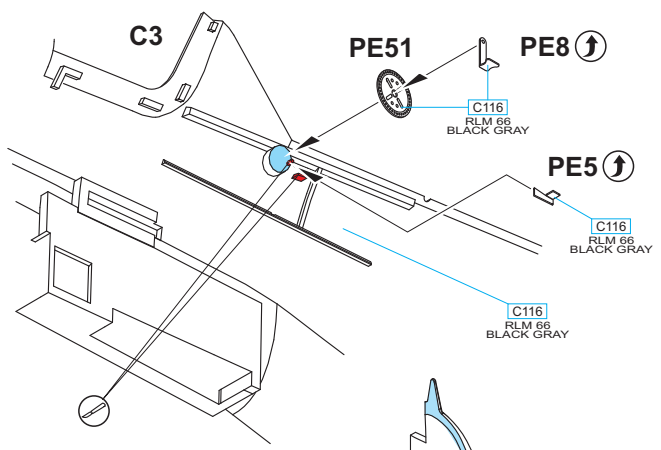
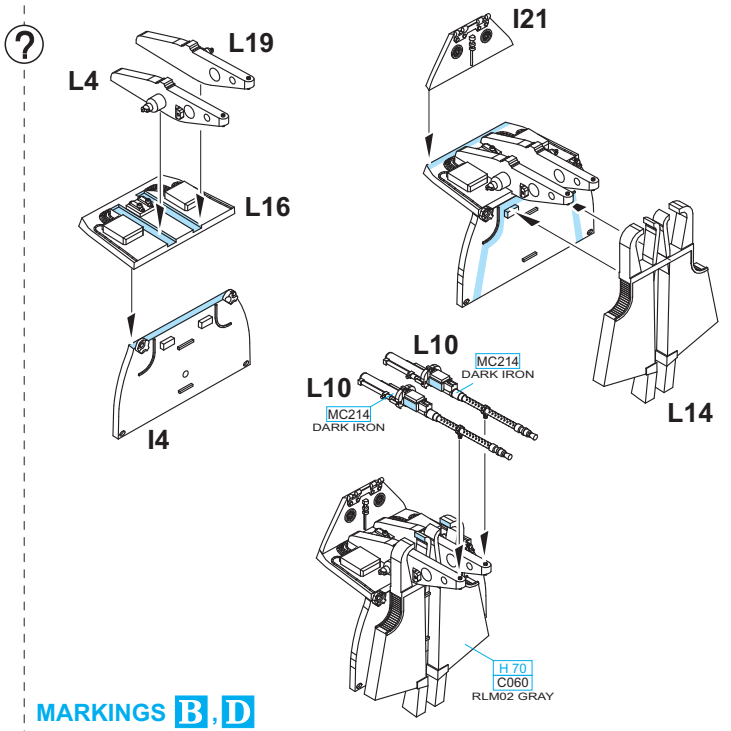
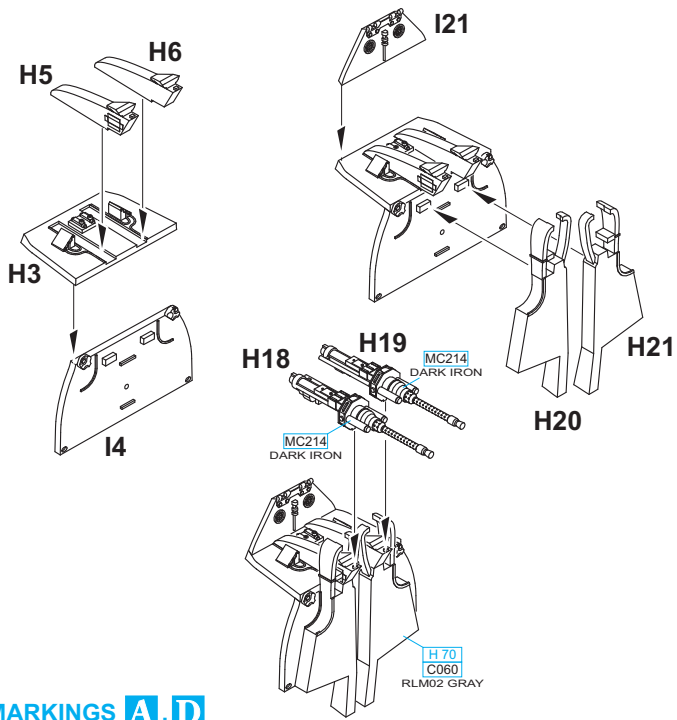

IF K23/ K2 DROP TANK RACK IS TO BE INSTALLED
 JEN POKUD BUDETE INSTALOVAT ZÁVĚSNÍK K23/ K2

ANTENNA
 ? ⓘ - 0,6 mm
 MARKING A ONLY

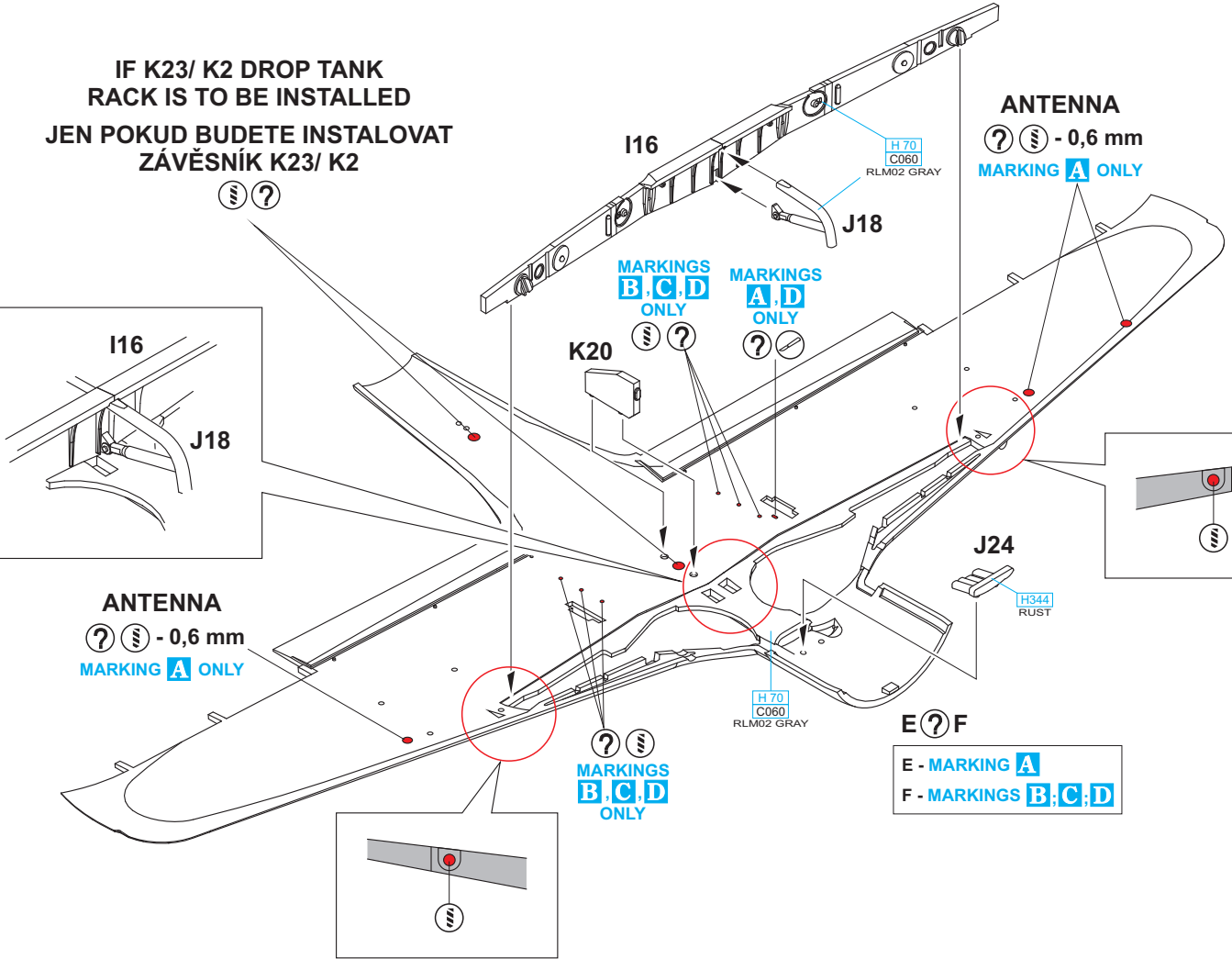

ANTENNA
 ? ⓘ - 0,6 mm
 MARKING A ONLY

E ? F
 E - MARKING A
 F - MARKINGS B, C, D

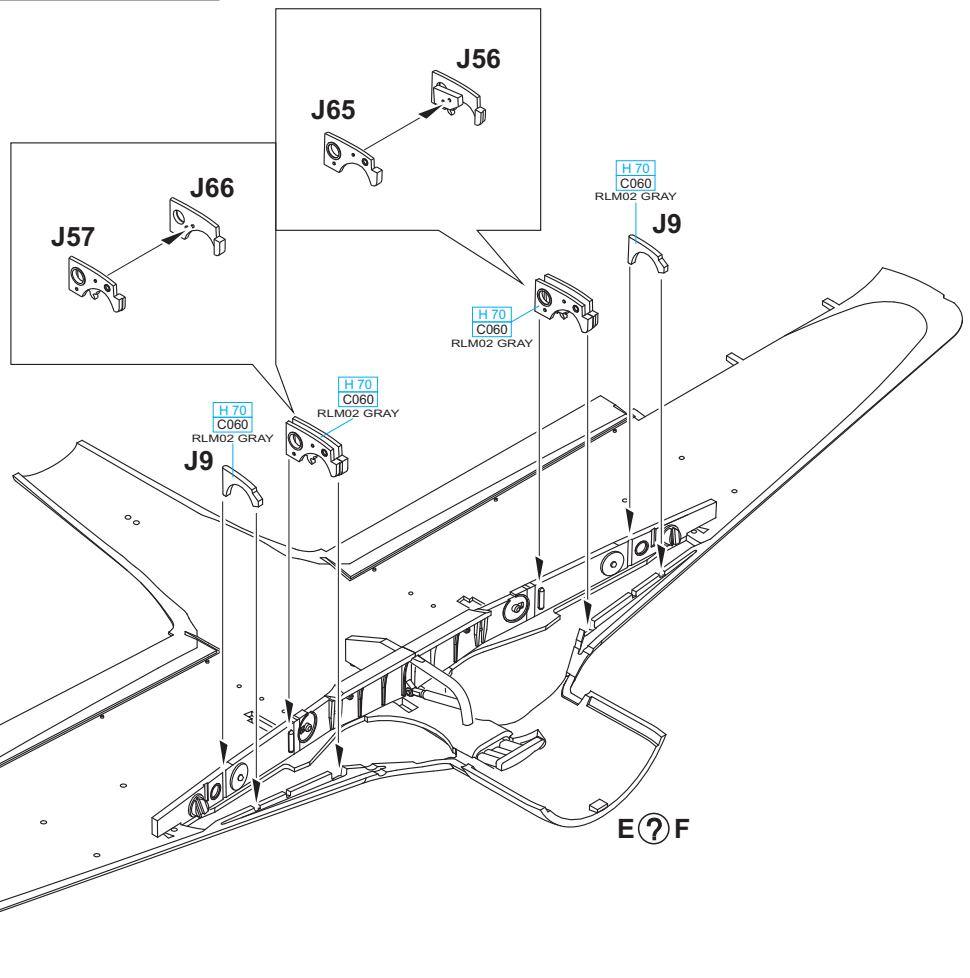

E ? F

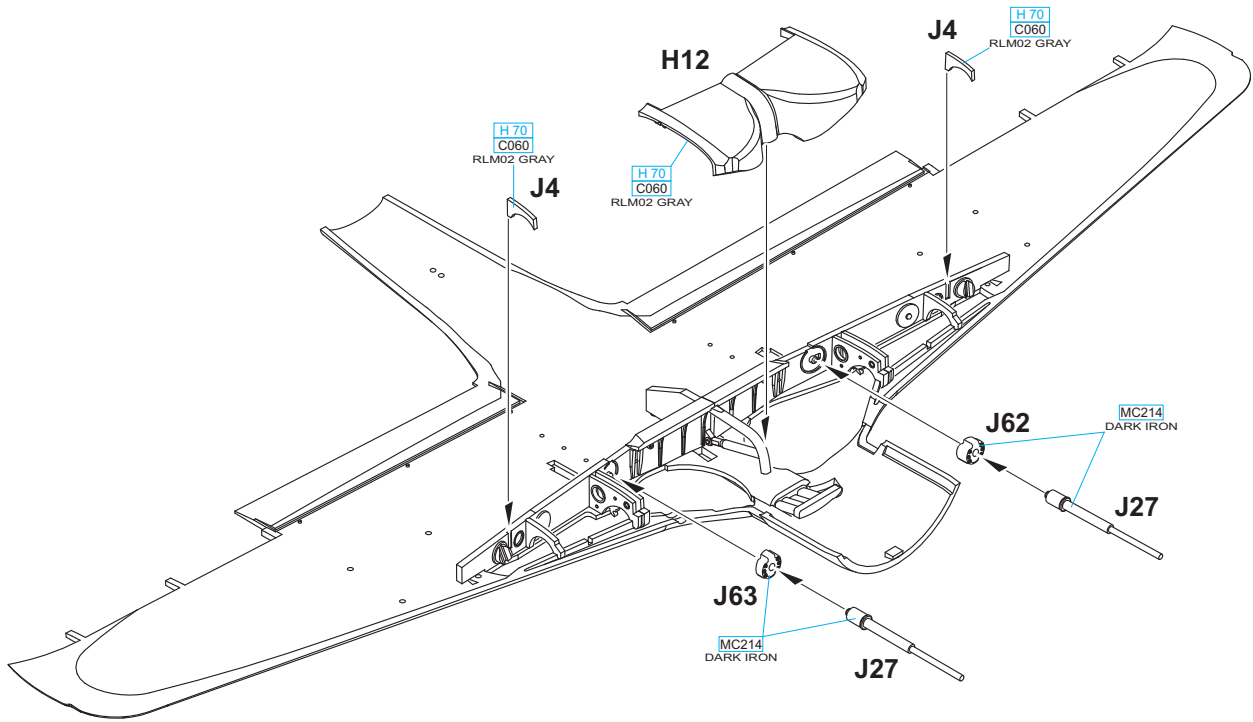

**DON'T USE PART J3
IF CANNON BAY HATCH I18/ I19
IS TO BE CLOSED POSITION
NEINSTALUJTE DÍL J3
POKUD MÁ BÝT KRYTŮ KANÓNU
I18/ I19 ZAVŘENÝ**

J3
MC214
DARK IRON

I14
H 70
C060
RLM02 GRAY

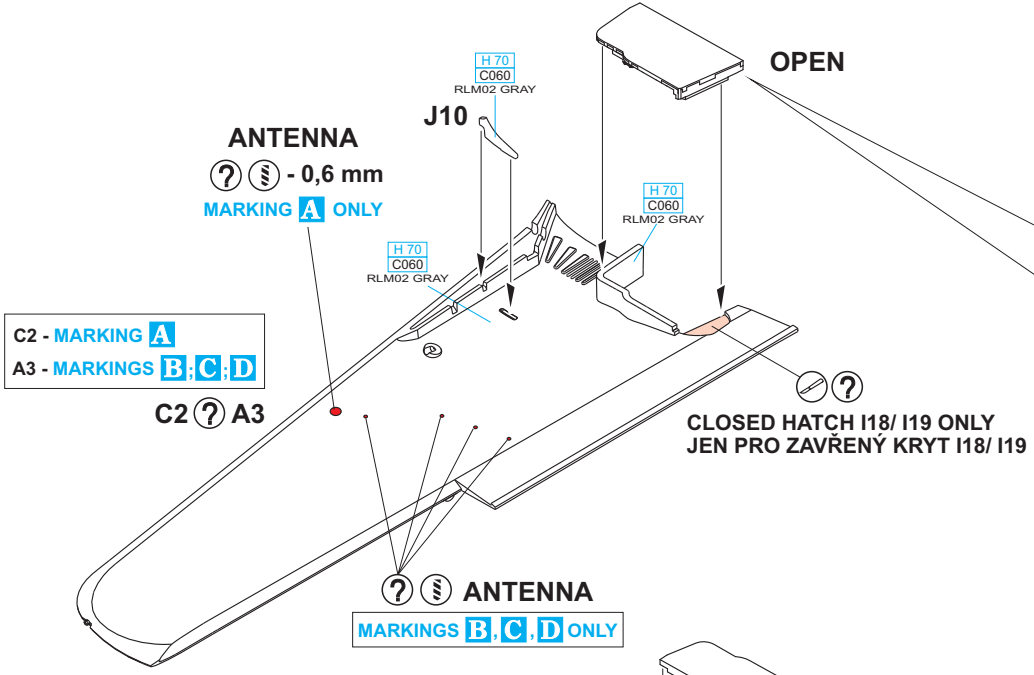

**DON'T USE PART J3
IF CANNON BAY HATCH I18/ I19
IS TO BE CLOSED POSITION
NEINSTALUJTE DÍL J3
POKUD MÁ BÝT KRYTŮ KANÓNU
I18/ I19 ZAVŘENÝ**

J3
MC214
DARK IRON

I15
H 70
C060
RLM02 GRAY

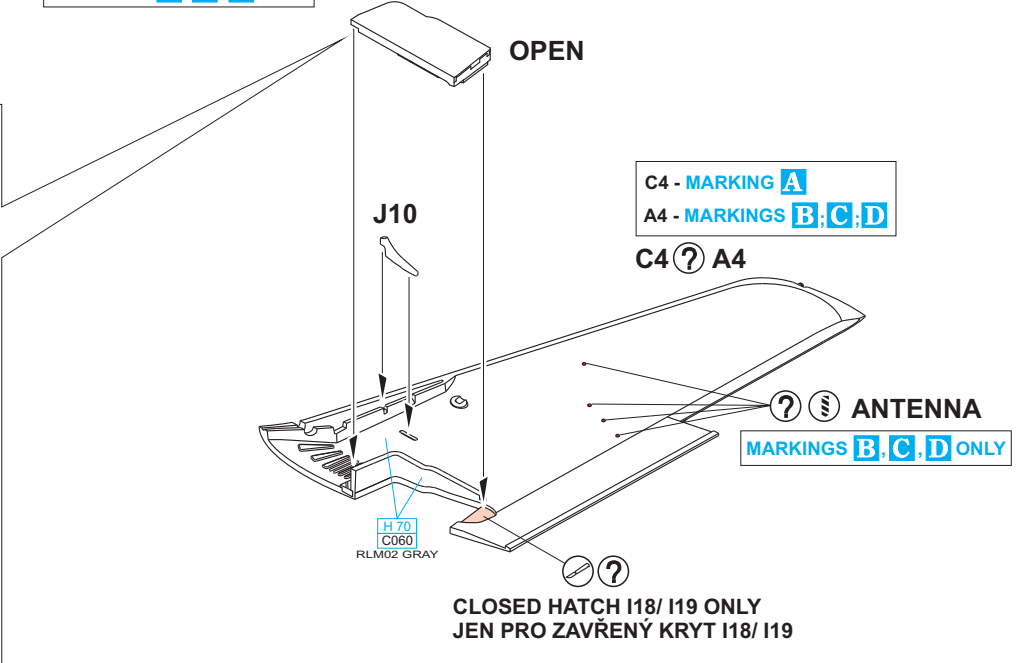

C4 - MARKING **A**
 A4 - MARKINGS **B;C;D**

A4 ? C4

C2 - MARKING **A**
 A3 - MARKINGS **B;C;D**

A3 ? C2

E ? F

E - MARKING **A**
 F - MARKINGS **B;C;D**

MARKINGS **A;D**

PE19

PE22

PE30

PE32 ? PE33

OPTIONAL:
 decal 29

MARKINGS **B;C**

H27

PE20

PE23

C116
 RLM 66
 BLACK GRAY

N4

C116
 RLM 66
 BLACK GRAY

PE30

PE32 ? PE33

OPTIONAL:
 decal 29

H7

H47
 C041
 RED BROWN

K6

C116
 RLM 66
 BLACK GRAY

N4

H47
 C041
 RED BROWN

K6

GLUE PART H27 INTO PART K6 FIRST,
 THEN GLUE PHOTO-ETCHED PARTS
 PE17/PE18 ONTO PART H27
 VLEPTE NEJPRVE DÍL H27 DO DÍLU K6,
 POTOM VLEPTE KOVOVÉ DÍLY
 PE17/PE18 NA DÍL H27

K16

K9

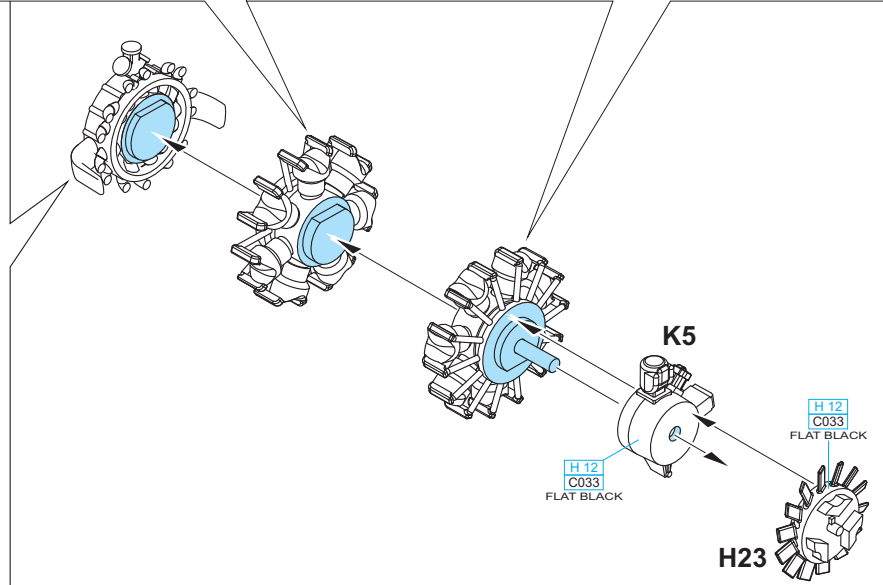
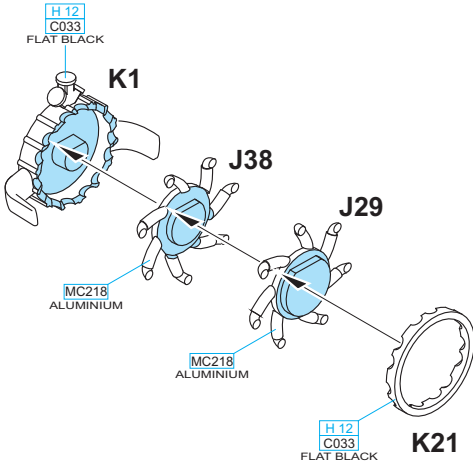
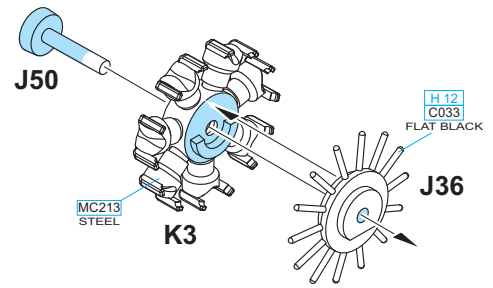
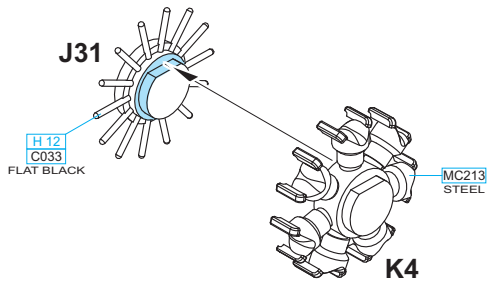

TEMPLATE ONLY! DO NOT GLUE!
THIS SERVES TO ATTAIN EXACT EXHAUST POSITION AND IS DISCARDED AFTERWARDS

ŠABLONA! NELEPIT!
SLOUŽÍ K USAZENÍ VÝFUKŮ DO SPRÁVNÉ POZICE. PO NALEPENÍ VÝFUKŮ SE ODSTRANÍ

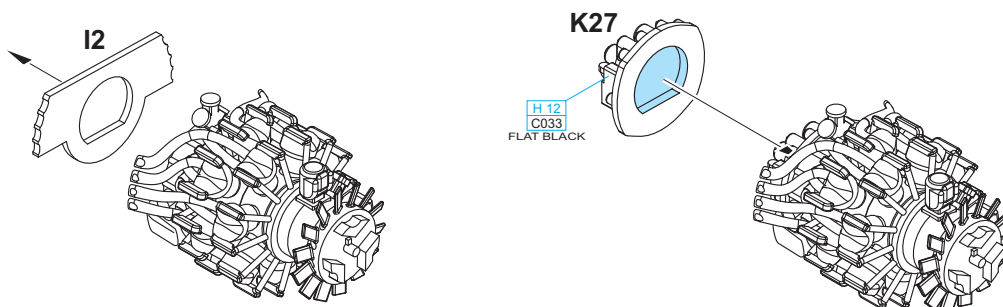
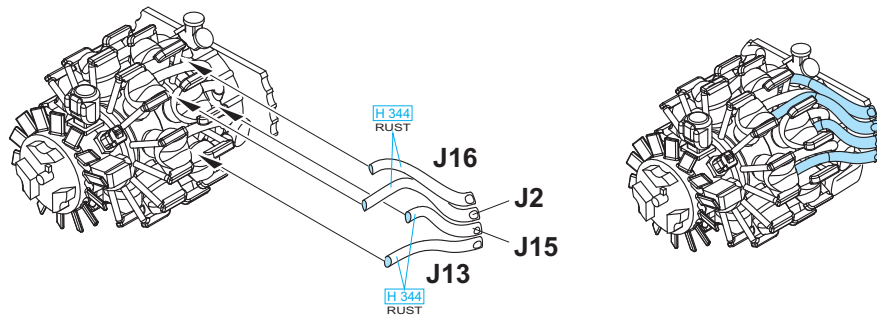
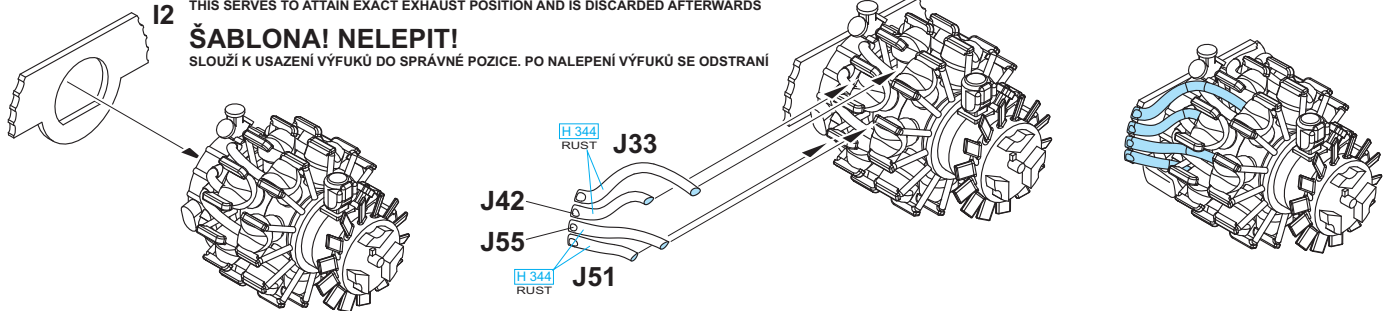

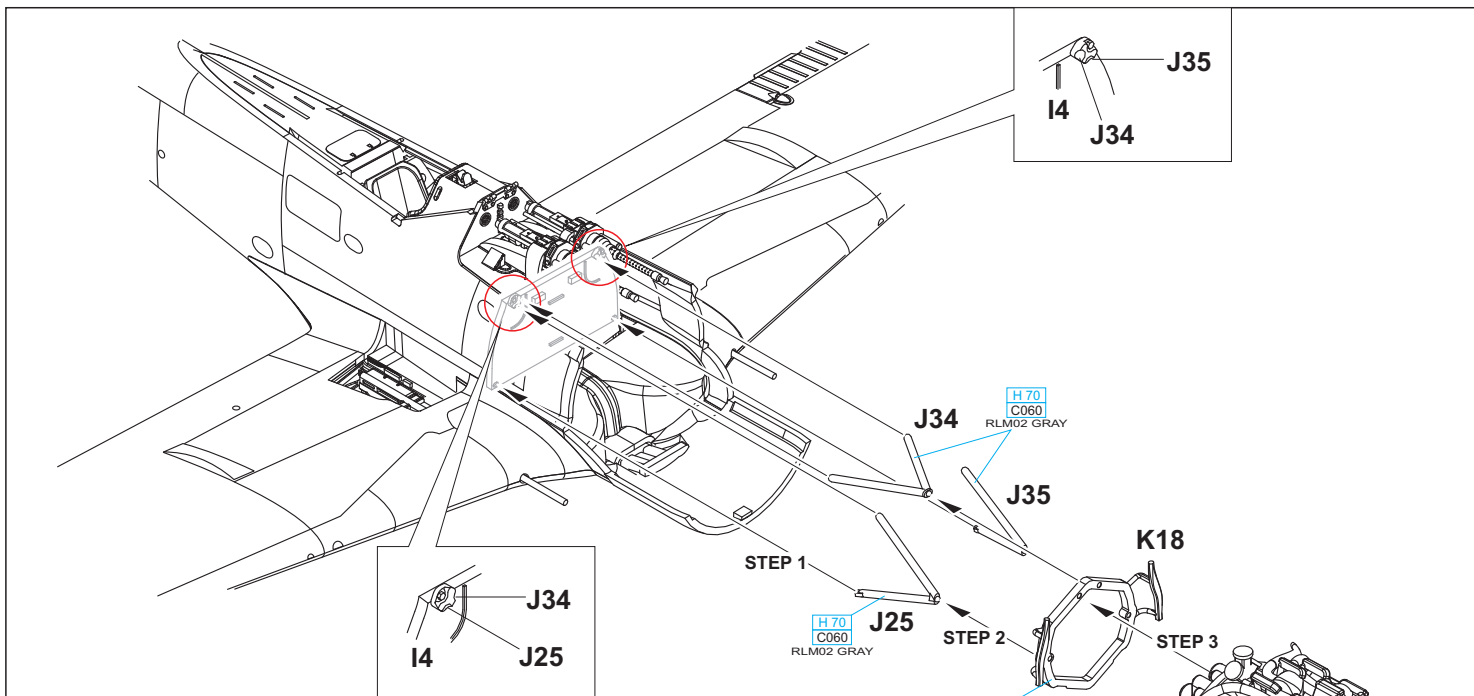

**DON'T USE
IF CANNON BAY HATCH I18/ I19
IS TO BE CLOSED POSITION
NEINSTALUJTE
POKUD MÁ BÝT KRYT KANÓNU
I18/ I19 ZAVŘENÝ**

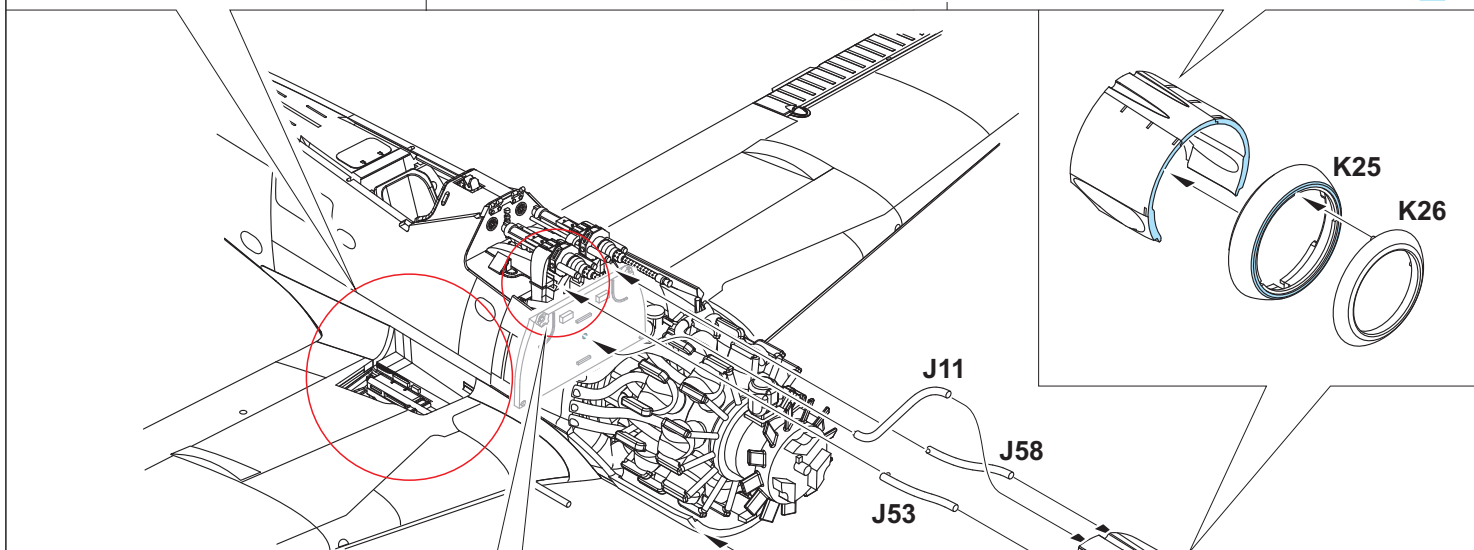
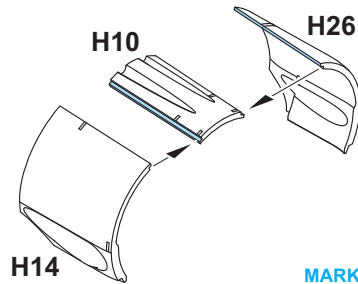
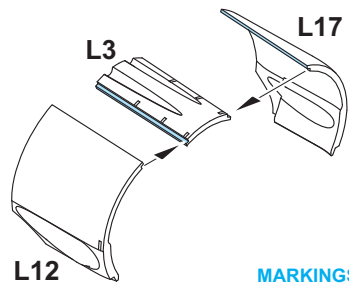
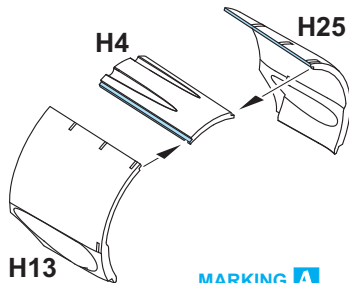
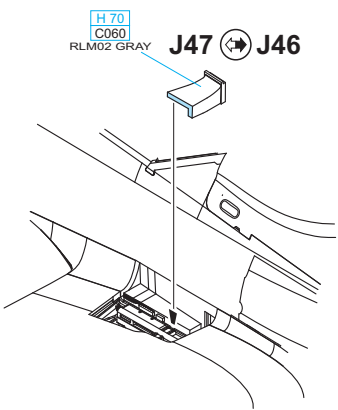

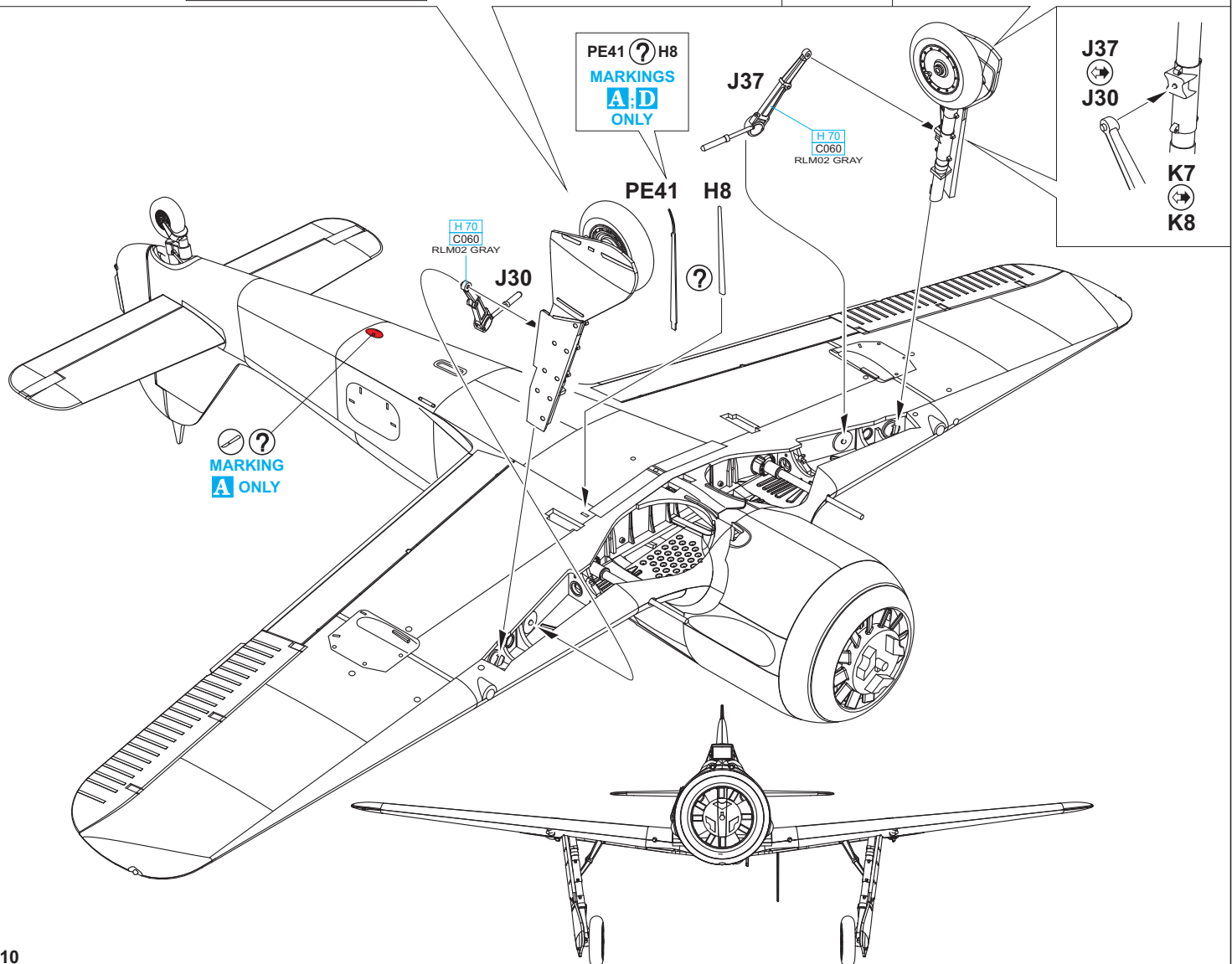
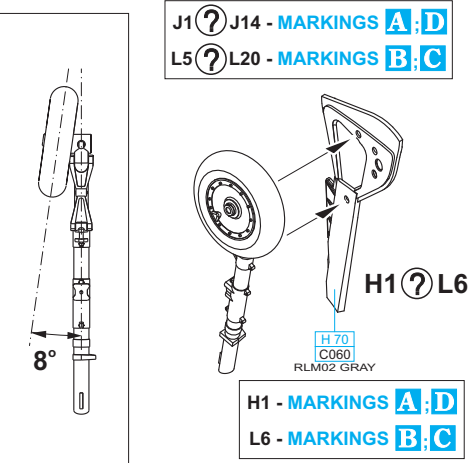
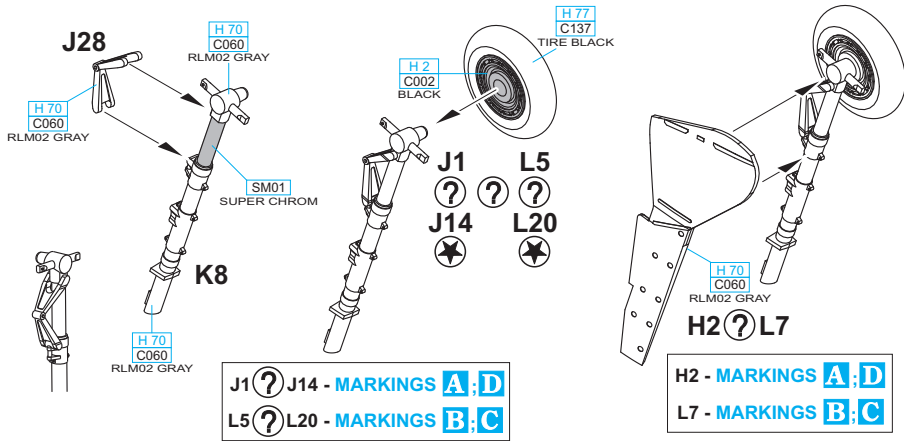
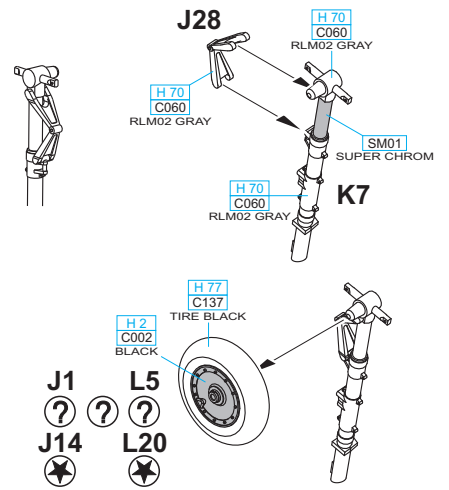
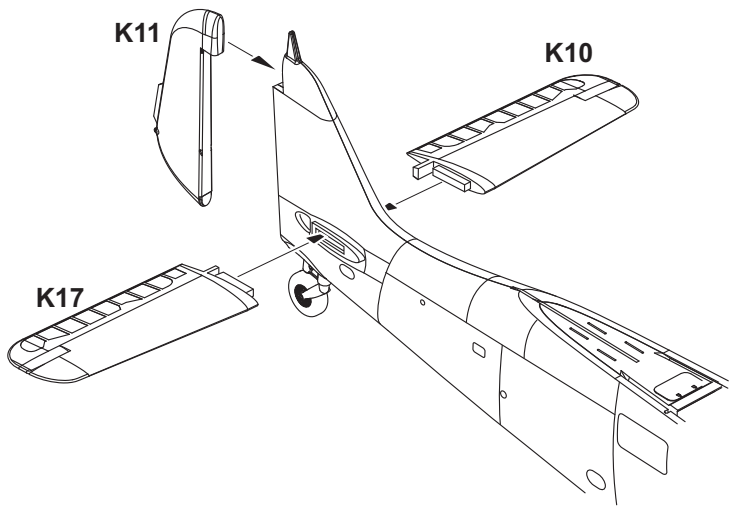

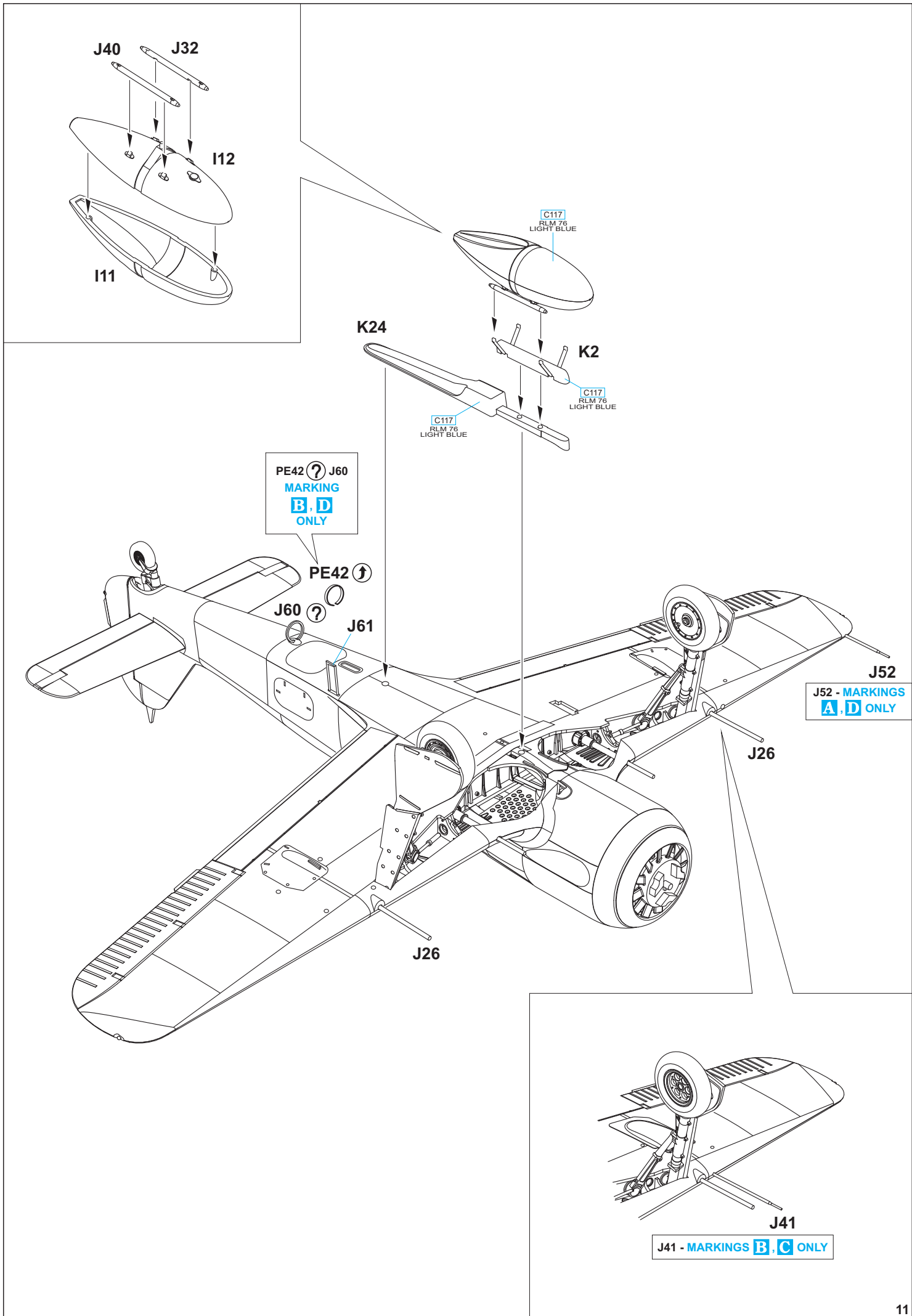

J40 J32

I12

I11

C117
RLM 76
LIGHT BLUE

K24

K2

C117
RLM 76
LIGHT BLUE

C117
RLM 76
LIGHT BLUE

PE42 ? J60
MARKING
B, D
ONLY

PE42 ↑

J60 ?

J61

J52

J52 - MARKINGS
A, D ONLY

J26

J26

J41

J41 - MARKINGS B, C ONLY

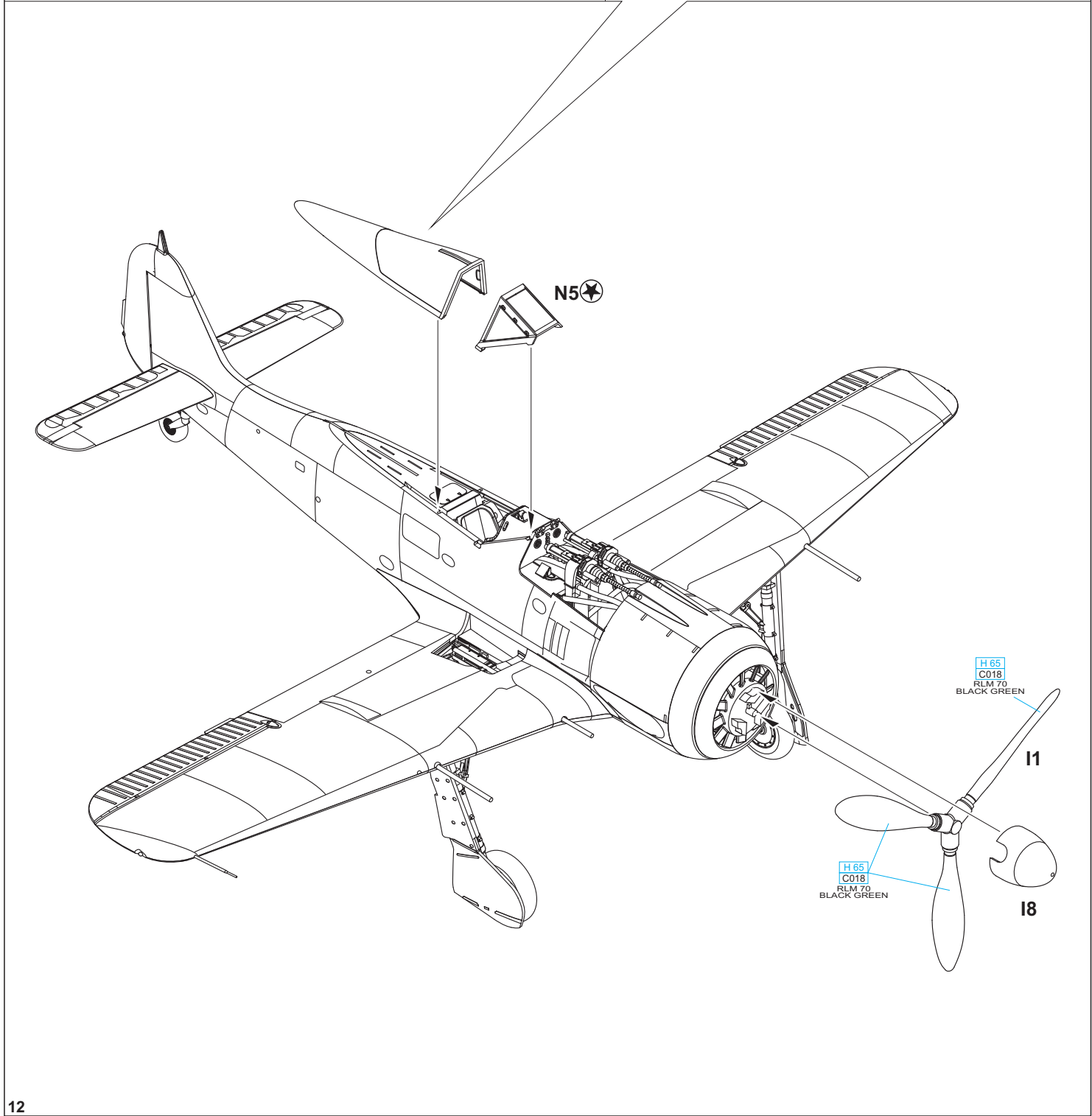
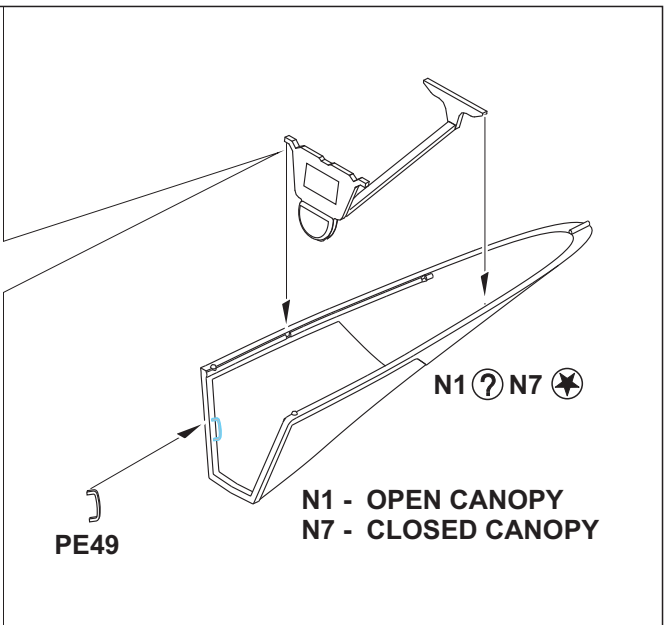
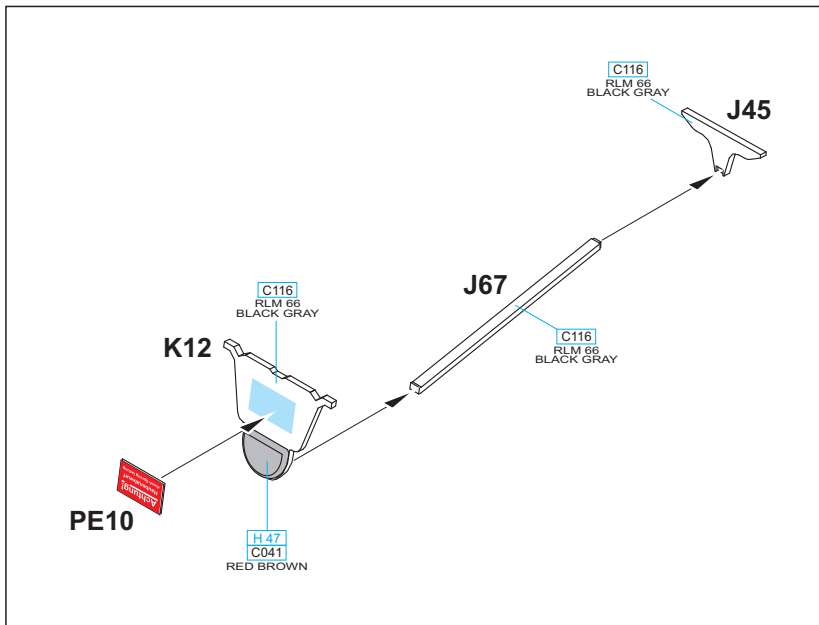

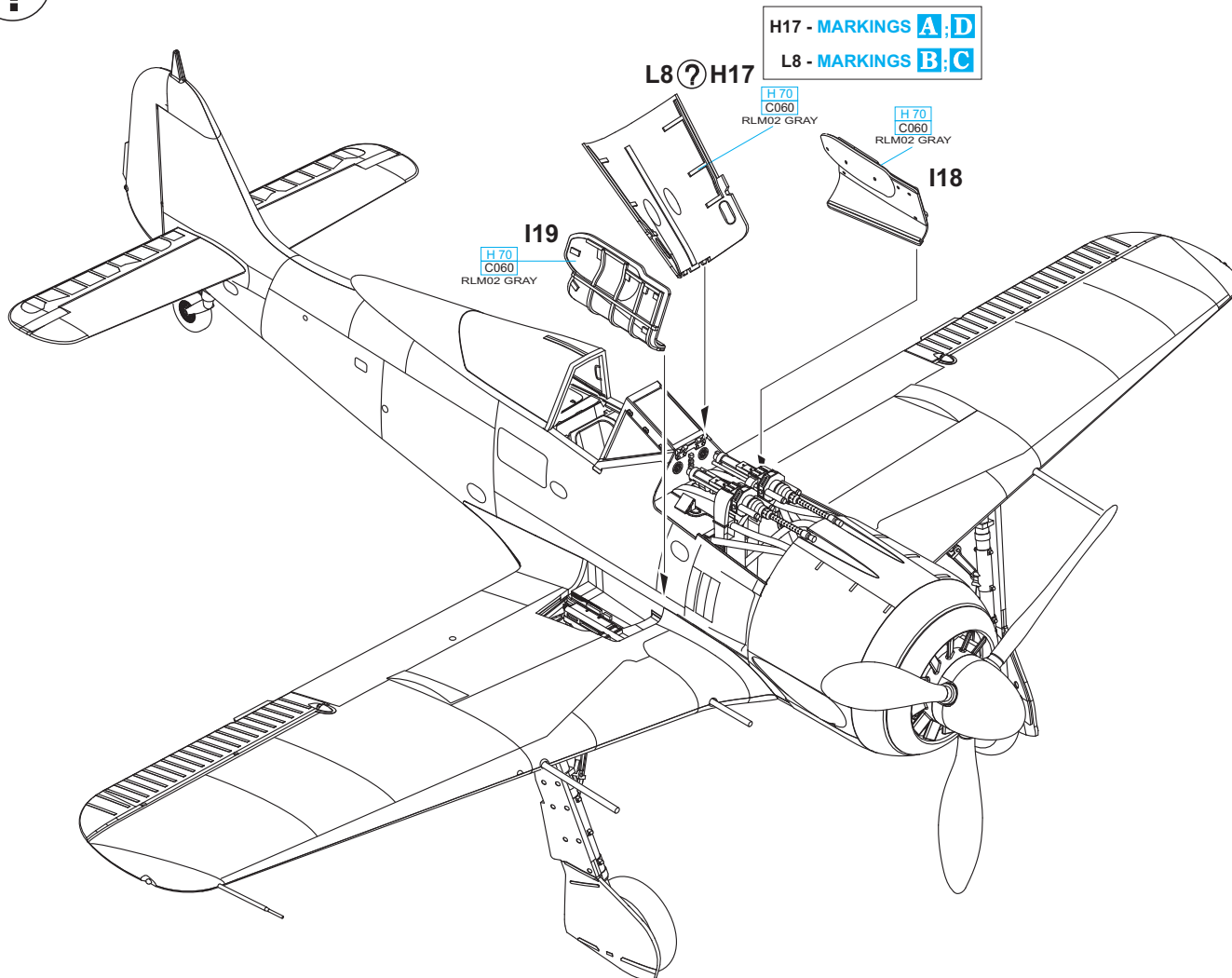
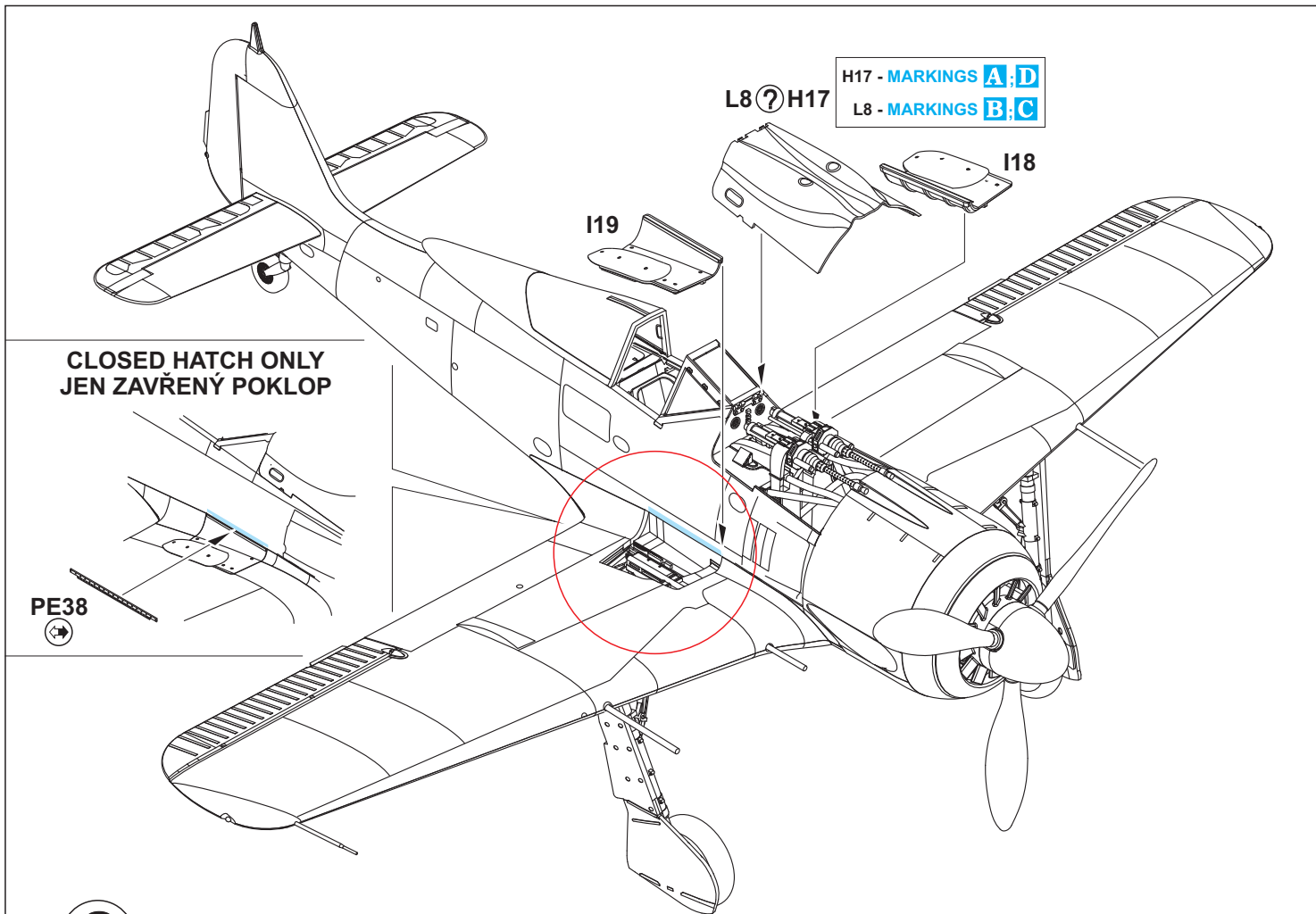

MARKINGS A, D ONLY

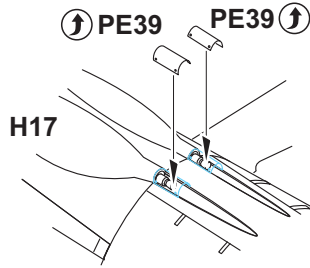

A

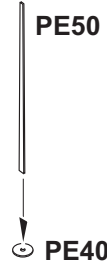

B

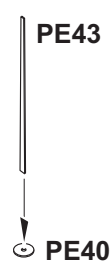

C



MARKINGS B, C, D ONLY

A B C

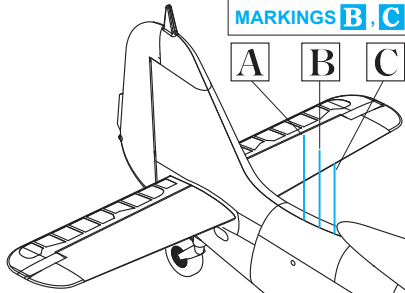

MARKINGS B, C, D ONLY

A B C

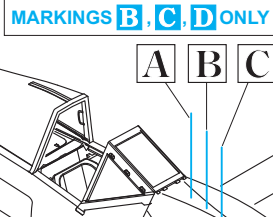

MARKINGS B, C, D ONLY

A 4 pcs.

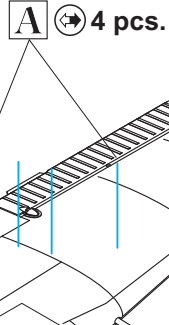

MARKING A ONLY

M3

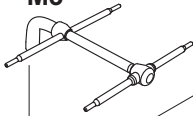

M1 - MARKINGS A, B ONLY

M1

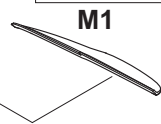

M2

M2 - MARKINGS A, B ONLY



MARKING A ONLY

M3

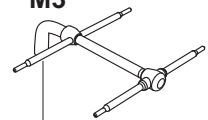

MARKINGS B, C, D ONLY

B 6 pcs.

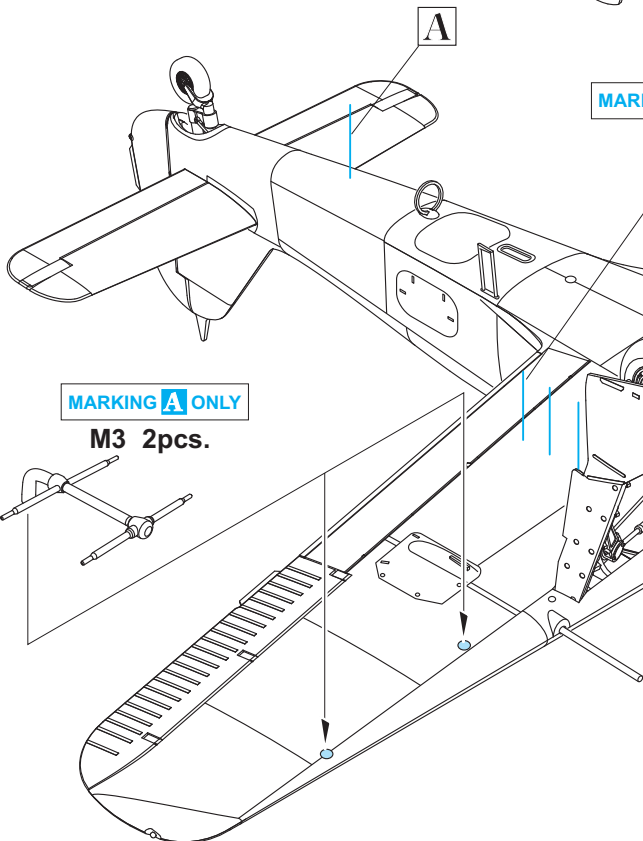

MARKING A ONLY

M3 2 pcs.

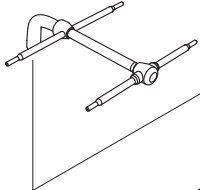

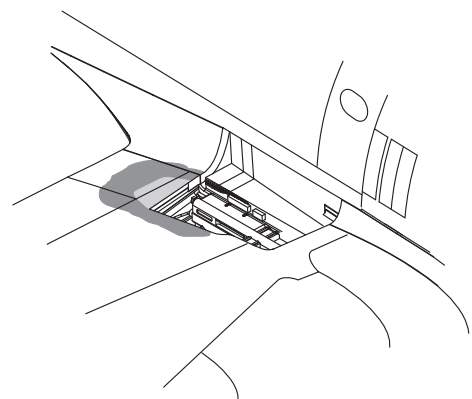
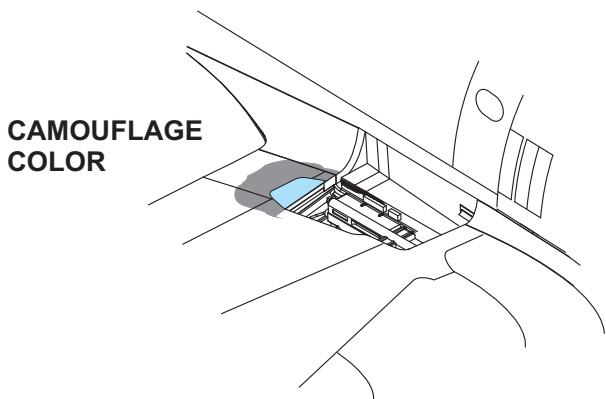
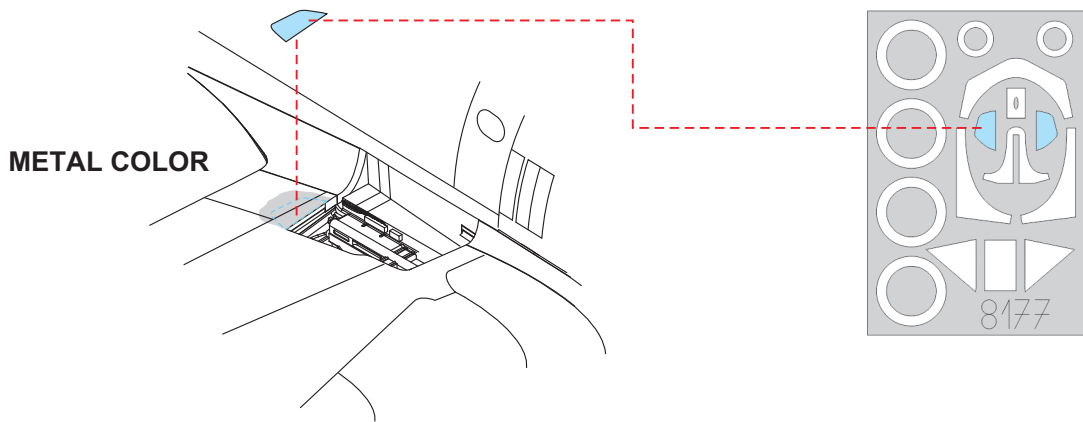
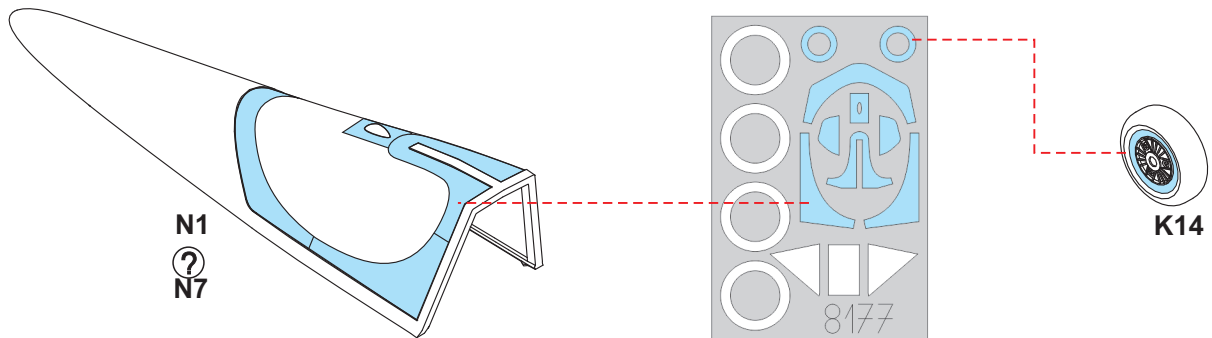
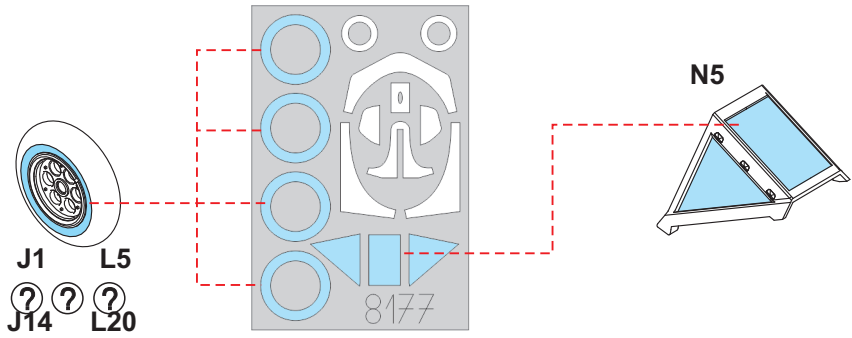

A A-8/R11 'Neptun' Fhj. Ofw. Gunter Migge, 1./NJGr. 10, Werneuchen, 1944

The Fw 190A-8/R11 'Neptun' was also used in the night fighting role by Nachtjagdgruppe 1 (formed January 1st, 1944, from a part of JG 300), operating primarily from fields east of Berlin. The unit, formed with only three Staffeln with a very wide variation of types in service (including Bf 109, Bf 110, Ju 88, He 219 and Ta 154 besides the Fw 190), was tasked with the defense of important German cities. Above all, the unit tested new equipment for Luftwaffe night fighters under combat conditions, including Fw 190 versions from A-5 to A-8, including this machine from January to July, 1944 when they began to switch to the Bf 109G-6. With them, they transformed into a Mosquito hunting unit. In February, 1945, the unit became 2./NJG 11. One of the pilots of 1. Staffel NJGr. 10 was Fhj. Ofw. Gunter Migge, a former night fighter pilot of JG 300. His Fw 190 carried the Wilde Sau emblem, and also carried the inscription 'Kognakpumpe' and a glass of Migge's favorite poison. The border of the emblem, as well as the noted inscription, were in all probability, red. However, black cannot be ruled out. The aircraft carried the standard camouflage scheme of RLM 74/75/76, with the only attempt to darken the scheme being the less common, for this timeframe, the 'Adlerflugel' in the form of the black wedge behind the exhaust stacks. The spinner was black. The bottom white segments of the fuselage balkenkreuz were subdued. The often quoted W.Nr. of 29210 is probably incorrect, but is supplied on the decal sheet, just in case. The kill marks on the rudder are in the form of simple white bars. The tally includes victories achieved by the pilot when flying with JG 300. Even so, Gunter Migge, with JGr. 10, achieved several kills flying this aircraft. Additional Sources: Luftwaffe at War: Nightfighters over the Reich; Classic Colours: Luftwaffe Night Fighter Units; Kagero: Fw 190, Vol. 1,3.

ČESKOU VERZI TEXTU NALEZNETE NA
www.eduard.com/s/8177

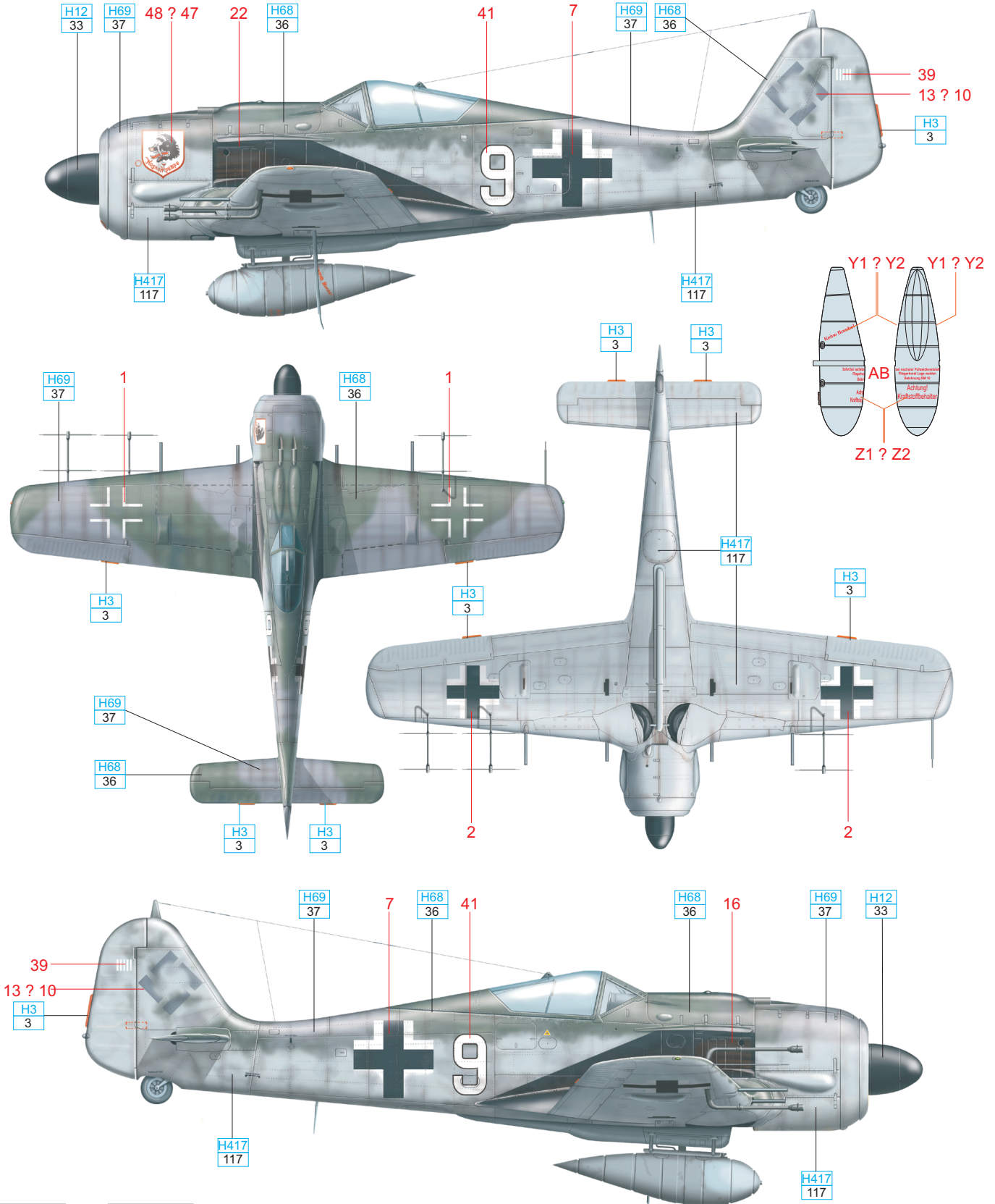

BLACK	H12 33	RED	H3 3
RLM 76	H417 117	RLM 75	H69 37
RLM 74	H68 36	RLM 70	H65 18

B A-6/R11, W.Nr. 550143, Flown by Oblt. Fritz Krause, 1./NJGr 10, Werneuchen Airfield, Germany, January, 1944

NJGr 10 was formed as a nightfighter unit on January 1, 1944. It was equipped with various types of aircraft, the 1st Staffel flew Bf 109Gs and Fw 190As. The FuG 217 Neptun radar was installed in NJGr. 10 aircraft to test its efficiency under combat conditions. A total of 48 Fw 190As were converted to the nightfighter configuration. Fritz Krause flew the aircraft depicted for a short period only as in the early summer of 1944, the NJGr 10 Fw 190As were handed over to fighter schools and were replaced with the Bf 109G-6/AS. The Messerschmitts were more capable in intercepting Allied bombers and Mosquitos. The origins of the badge on the cowling can be found with JG 300, as NJGr 10 was formed using JG 300 pilots.

ČESKOU VERZI TEXTU NALEZNETE NA
www.eduard.com/s/8177

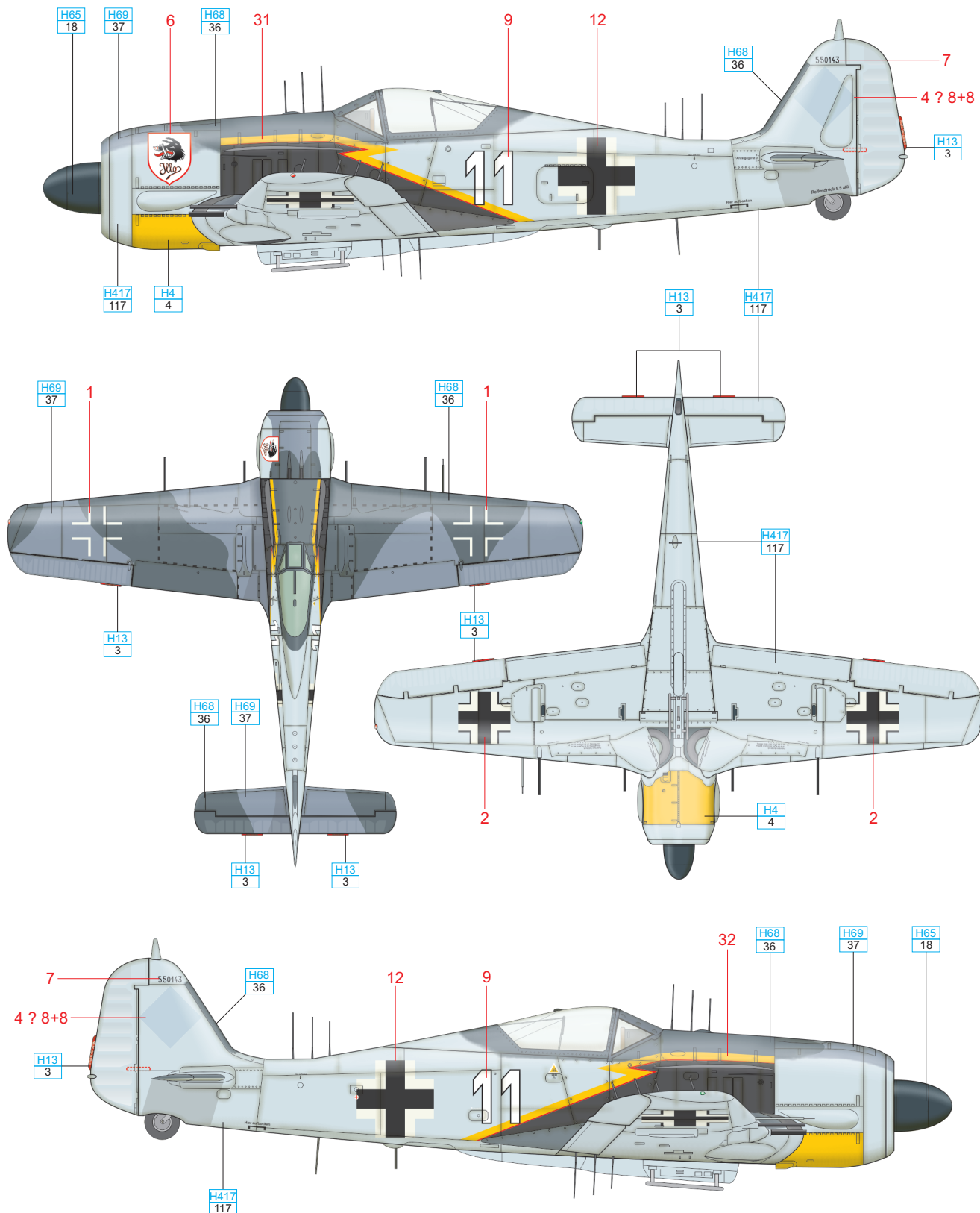

RED	H3				
	3				
YELLOW	H4	RLM 76	H417	RLM 74	H68
	4		117		36
				RLM 75	H69
					37
				RLM 70	H65
					18

C A-6/R-11 'Neptun' II./JG 300, Lobnitz, Fall, 1943

Jagdgeschwader 300 'Wilde Sau' was formed from JG Herrmann (hence 'B' marking) in July, 1943 with the main task allotted it being the perfecting of single-engined aircraft night fighting tactics. Besides the visual acquisition of targets, testing was initiated using on-board radar systems. The Fw 190 was equipped with 'Neptun', along with associated radar antennae. The illustrated Fw 190A-6 'Black 8', field modified R-11 for night fighting, was one of the Neptun equipped aircraft of JG 300. What makes this aircraft even more interesting is its camouflage application. The search for effective camouflage schemes gave rise to interesting color variations. The pictured Fw 190 received a lighter spray of RLM 76 over the top portions of the fuselage that blended into the darker sides of RLM 75 and 74 and into the RLM 76 bottom. Known photographs of this aircraft have been interpreted as the sides of the fuselage being composed of sharply demarcated RLM 76 and 74. Closer inspection reveals that the contrast between the darker and lighter shades were not so strong, and further research leads to the presentation here. The top and bottom camouflage colors are RLM 74/75/76. The Wilde Sau emblem is in its classic style as used by JG 300 on a yellow background and as per the usual practice of the unit, appeared only on the left side. Version of the landing gear bay is not determined for this particular plane. There could be used two alternatives for the lower wing area – frame F (late style) or frame G (early style). In case of applying the F part, the tire J1 or J14 (and doors H1 and H2) should be used. In case of applying the G part, the tire L5 or L20 (and doors L6 and L7) should be used. Additional Sources: Classic Colours: Luftwaffe Night Fighter Units, pg 120; Eduardo Soler & Aurelio Gimeno: Fw 190 and Ta152

ČESKOU VERZI TEXTU NALEZNETE NA
www.eduard.com/s/8177

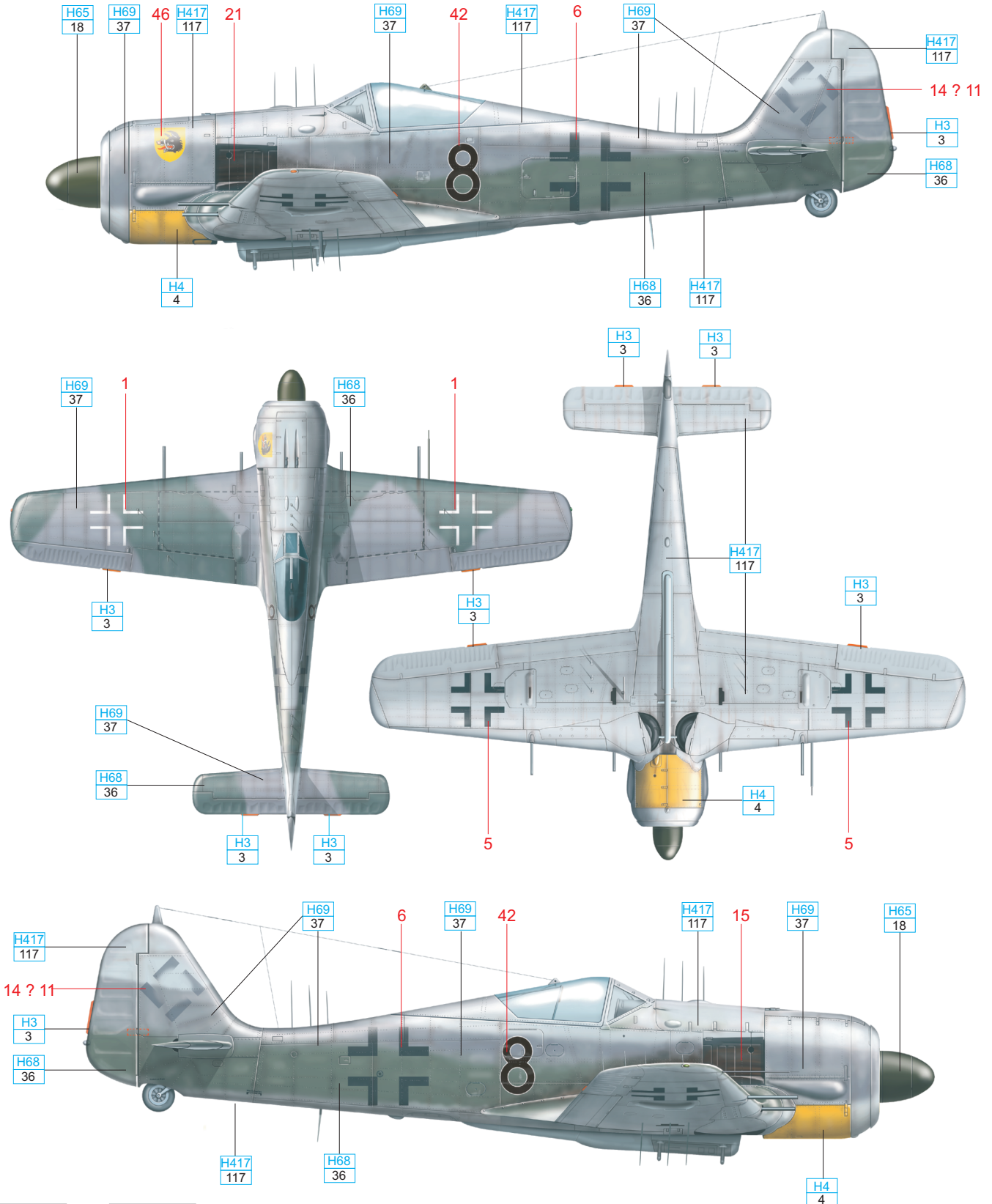

YELLOW	H4 4	RED	H3 3
RLM 76	H417 117	RLM 75	H69 37
RLM 74	H68 36	RLM 70	H65 18

