

**TITAN MODEL KITS**



# **1:72 A380 Assembly Guide**

15 February 2025  
Revision 1.0

## Thank You for Purchasing a Titan Model Kit!



I'm Chris and I own Titan Model Kits. First and foremost, I'm a modeler. I created these kits simply because I was tired of waiting for someone, someday to create the kits that I wanted. I created this brand to share my model kits with fellow builders.

If you have questions during your build, drop me an email and I'll try to help. If you discover any missing or defective parts, let me know and I'll replace them. If you completely screw something up while building, let me know and I'll do my best to get you replacement parts. I truly want you to have a successful build and a good experience!

I'm always looking for ways to improve my products. If you have feedback, good or bad, please contact me and let me know your thoughts.

[titanmodelkits@gmail.com](mailto:titanmodelkits@gmail.com)

<https://www.facebook.com/TitanModelKits>

# Table of Contents:

General Guidance:	4
Naming Conventions:	5
Port and Starboard:	5
Flap Track Fairing Numbering:	5
Engine Position Numbering:	6
Working With Vacformed Parts:	7
Remove parts from sheet:	8
Remove Stock Thickness:	11
Thin Trailing Edges:	12
Drill out engine and flap track attachments:	13
Cut out wing & tail passthroughs:	14
Cutouts for other resin details:	14
Assembly:	15
Working With Resin Parts:	15
Removing Support Columns:	15
Removing Layer Lines:	16
Opening / Increasing Hole Diameter:	16
Uncured / Under-cured Resin:	16
Troubleshooting Resin Parts:	16
Assembly:	17
Filling gaps:	17
Decals:	19
Clear Parts:	21
Kit-Specific Guidance:	22
Vacform Parts to Cut Out:	22
Resin Part Cutout Locations:	22
Nose Weight:	24
Resin Subassemblies:	24
Installing Resin Surface Details:	24
Installing Subassemblies:	25
Installing Styrene Angle Strips:	25
Assembling the Fuselage Halves:	27
Assembling the Wings:	27
Assembling the Tail:	27
Mating Fuselage, Wings, and Tail:	27
Installing Flap Track Fairings:	27
Installing Engines:	28
Installing Additional Resin Details:	30
Installing Clear Cockpit Windows:	31
Antenna Installation Positions:	31
Decals & Paint:	32
References and Resources:	33
Record of Revisions:	34



## General Guidance:

Use caution when handling both vacform and resin parts as they may contain sharp edges or protrusions that could cut you!



Titan Model Kits are intended for experienced (intermediate to advanced) adult scale modelers. Kits will require you to measure, mark, cut, scratch-build, and modify various pieces.

Builders are cautioned to review the assembly guide in its entirety prior to beginning any work. This guide is provided only as a guide. You may choose to alter the sequence of steps, change techniques, or omit steps at your discretion. You will find the following tools useful in your build: hobby knife, dial calipers, ruler or measuring tape, drill with various bit sizes, rotary tool (Dremel or equivalent), sand paper of various grit, sanding block, styrene model cement (solvent based), and cyanoacrylate glue (Superglue or equivalent).

Always confirm that you are using the most recent version of the assembly guide. Assembly guides may contain images that do not correspond precisely to the physical kit parts. Physical parts are in a state of continuous improvement and you may have earlier or later versions of an individual part or kit than what is shown in the assembly instructions. The images are intended to provide you with general orientation only. Additionally some images are used to illustrate concepts which are common to multiple kits.

Screenshots of CAD models are used for concept illustration only and the images may contain elements that may or may not be present in the physical parts. For instance, cabin window and door outlines are shown in these images to help in visual orientation but are often not present in the physical parts. Screenshots may omit adjacent parts for clarity.

## Naming Conventions:

### Port and Starboard:

Parts intended for the port side often have a 'P' on the physical part. Parts intended for the starboard side often have a 'S' on the physical part.

**Port:** the left side of the aircraft, when aboard and facing forward.

**Starboard:** the right side of the aircraft, when aboard and facing forward

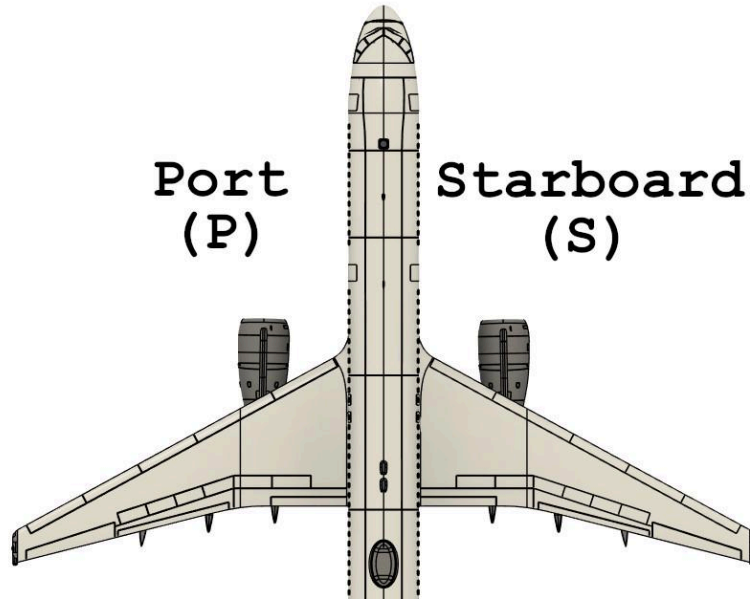

### Flap Track Fairing Numbering:

Flap track fairings are numbered according to position starting on the port side with #1 and progressing to the starboard side

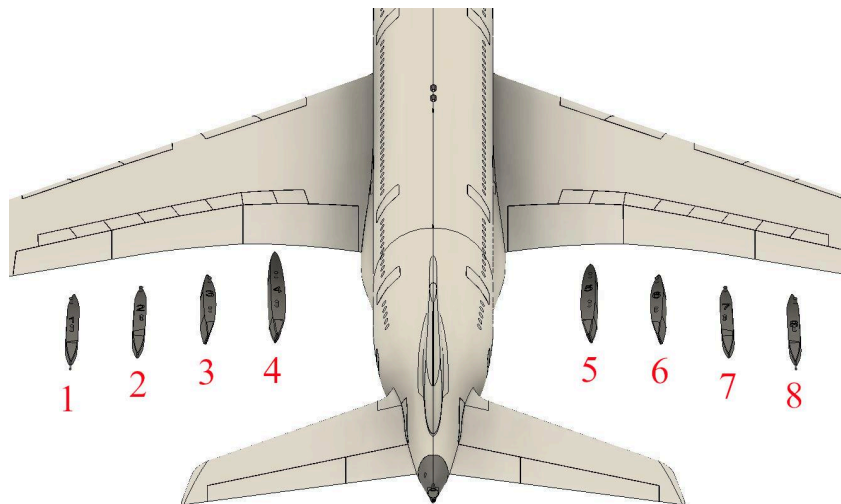

**Engine Position Numbering:**

Engines are numbered according to position starting on the port side with engine #1 and progressing to the starboard side

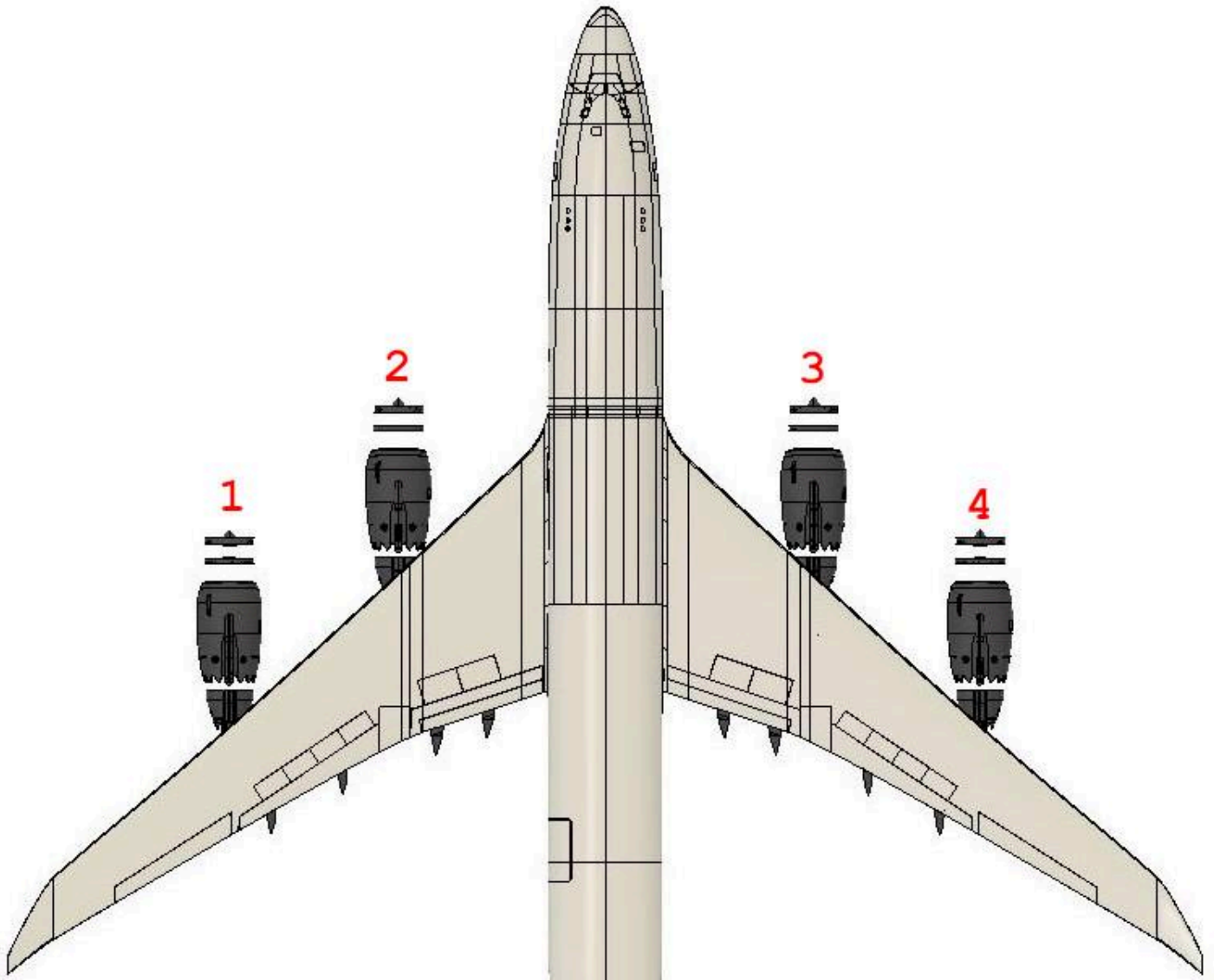

## Working With Vacformed Parts:

The fuselage halves, wing halves, and sometimes other large parts are vacuum formed from sturdy high-impact polystyrene plastic (HIPS). Vacformed parts are white in color. HIPS is very similar to the plastic used in injection-molded kits. Vacformed parts can be glued together using solvent-based model cements that chemically weld the parts together. This is the same way that you're accustomed to assembling an injection molded kit. Vacformed parts must first be cut out with a sharp knife prior to assembly.





### Remove parts from sheet:

First, identify exactly where you need to cut. The most common mistake here is made by incorrectly removing the wing carry-throughs. Titan Model Kits are designed with wings that carry all the way through the fuselage to meet in the very center of the model. This sets the correct dihedral and makes for a very strong finished model. See the section 'Kit-specific Guidance' for illustrations of where to cut for your specific kit.

Next, use a Sharpie marker (or equivalent) to trace around the outline of the parts that you wish to remove. This step is helpful for two reasons. First, it allows you to see exactly where you want to cut. Second, after you remove the parts from the backing sheet the black line will show you exactly how much sheet thickness you'll need to sand away.

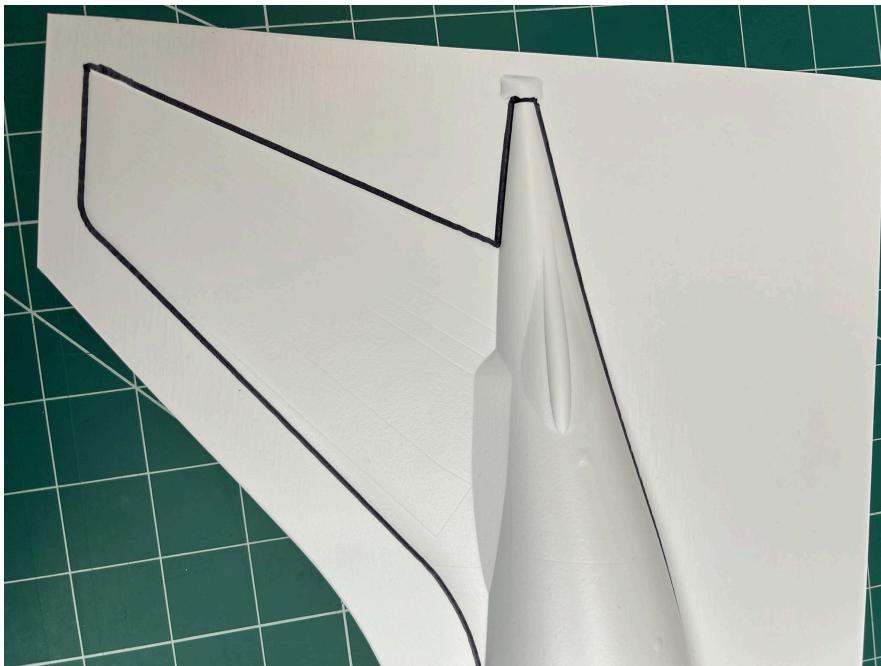

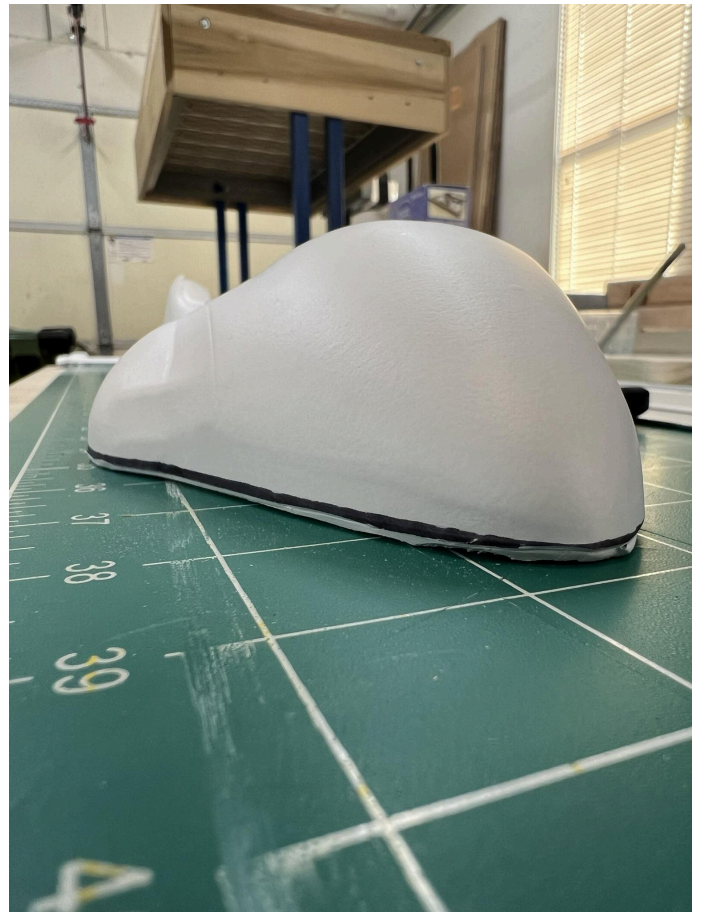

Next, score along the outline of the parts with a sharp utility knife. No need to cut completely through the plastic. Scoring the plastic with the hobby knife will create a weak point where you will then be able to snap the plastic and remove the part.

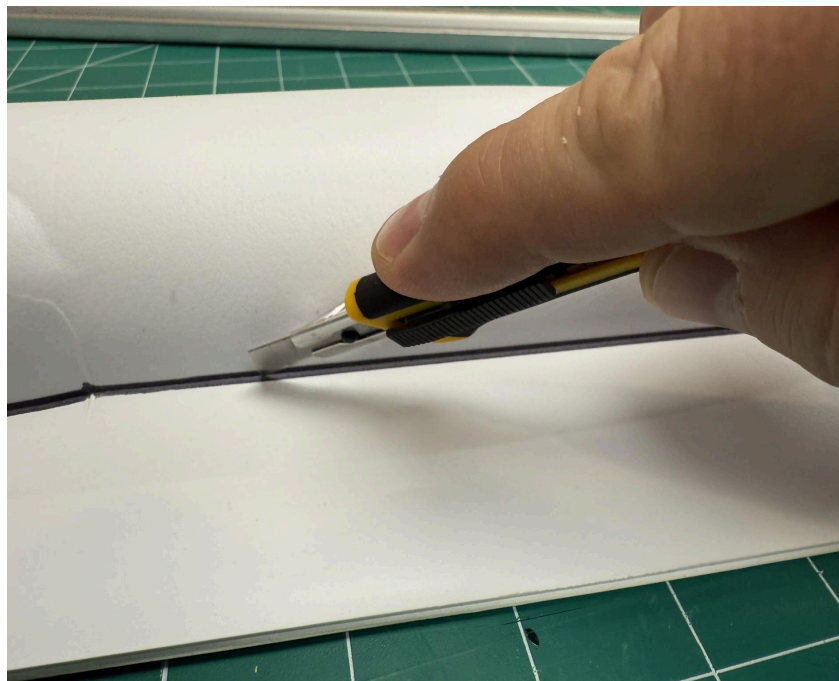

**Remove Stock Thickness:**

Once parts are cut away from their sheet they will still need to have the sheet thickness removed from them. As can be seen from the below photo, the .080" sheet thickness between the red lines should be removed. Coarse sandpaper in a sanding block is recommended to remove this material. Work slowly, checking progress often. **If you use a powered sanding belt, be very careful not to melt the plastic.**

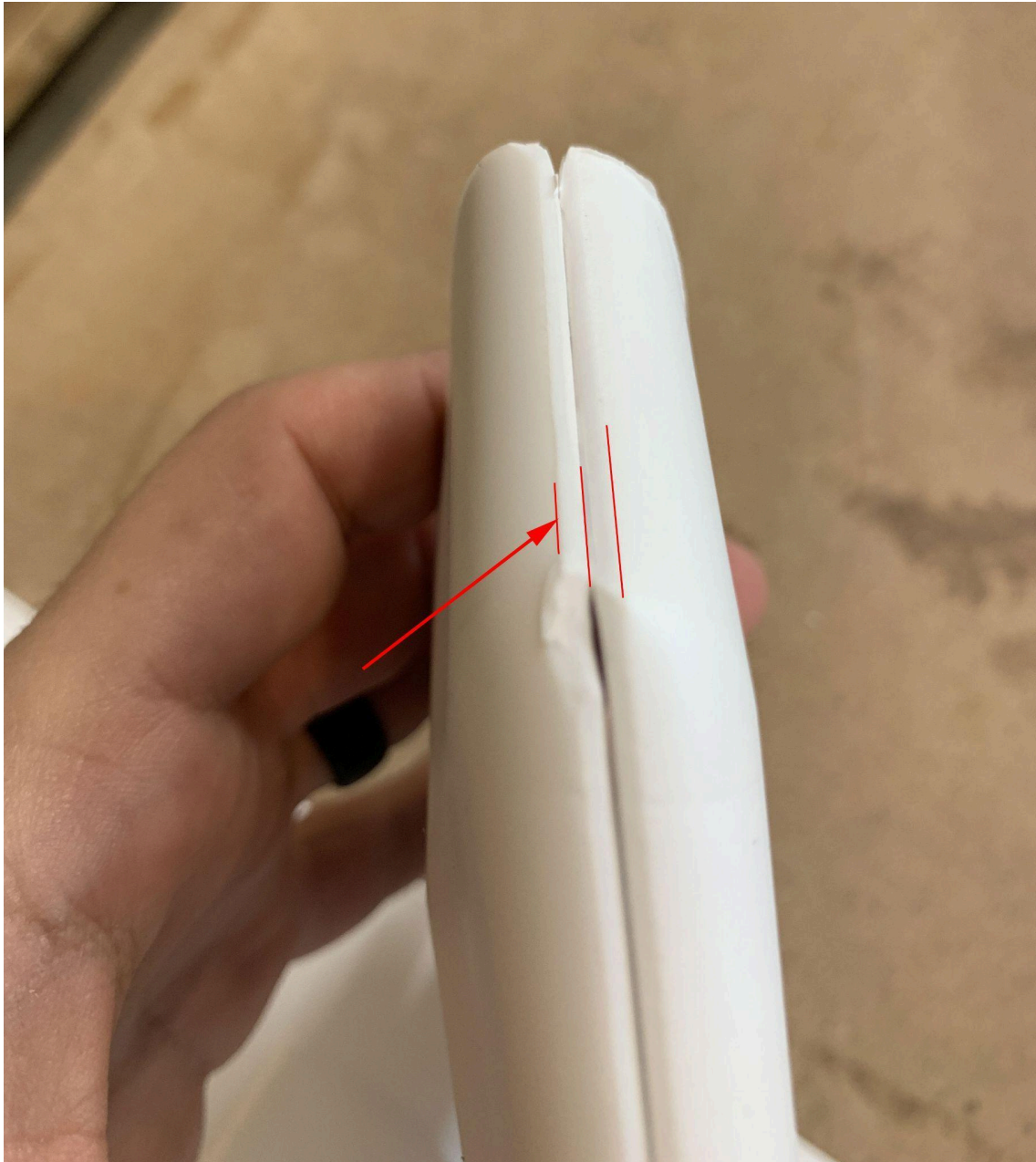

### Thin Trailing Edges:

As delivered, the trailing edges of the wings and tail parts are the thickness of the plastic sheet used to produce them. If left alone, assembling raw parts will result in a trailing edge that is too thick for scale. Using 220 grit sandpaper, thin all trailing edges from the .080" material thickness to approximately .010". Work slowly, checking thickness and consistency as you go. This will result in trailing edges that are more "to-scale". If you use a powered sanding belt, be very careful not to melt the plastic.

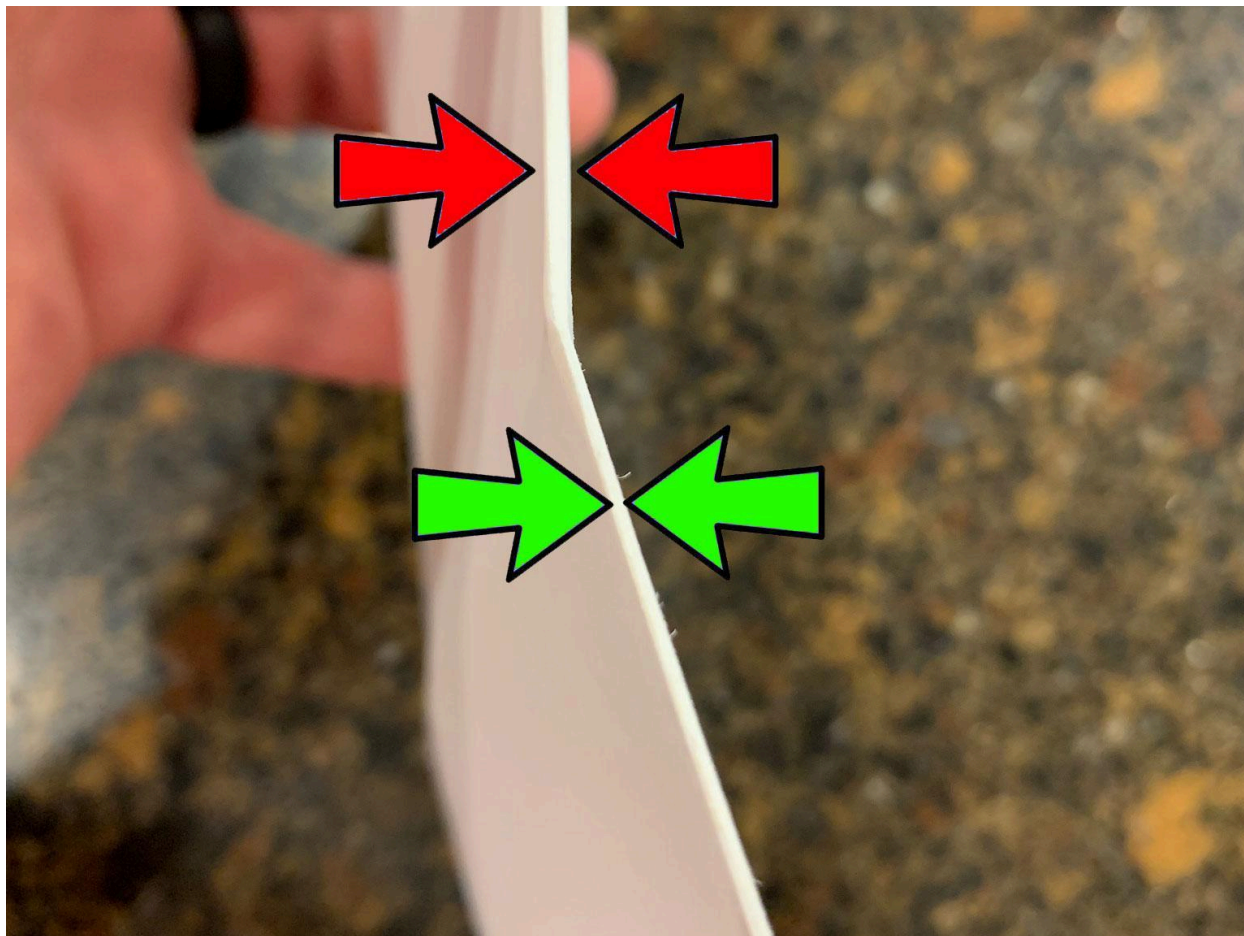

**Drill out engine and flap track attachments:**

The little dimples on the underside of the wings are your attachment points for engines and flap track fairings. Engine and flap track fairing attachment points should be drilled out with a 1/8" (3mm) brad-point drill bit.



**Cut out wing & tail passthroughs:**

Remove plastic to allow for the wing and tail assemblies to pass through the fuselage halves as shown. Check your work and the fit of the wing parts often to avoid removing too much material.

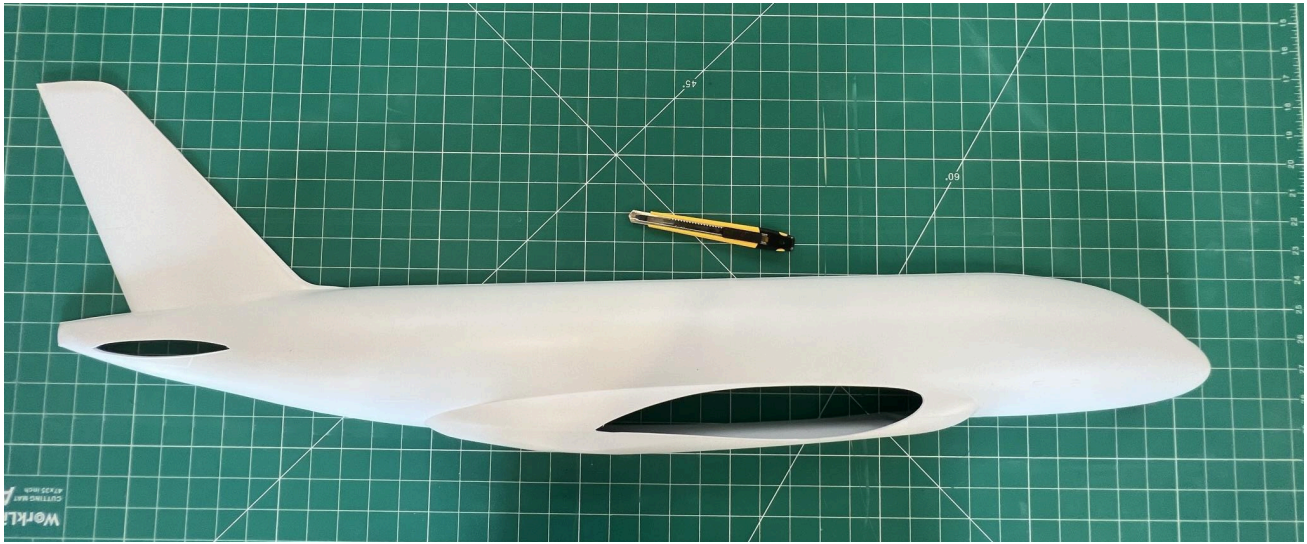

**Cutouts for other resin details:**

Most kits have resin surface details and parts that will need to be inserted into openings that you cut in the vacform parts. It is often helpful to pre drill some holes in the areas to be removed and then use a hobby knife to cut away the rest of the styrene. Always work slowly and check the fit of the resin detail part so that you don't remove too much material.



## Assembly:

Vacform parts should be glued to one another using solvent based model cements.



## Working With Resin Parts:

Titan Model Kits' ultra-high-resolution 3D printed parts are made from UV-cured resin and have similar hardness and strength to cast resin. 3D printed parts are grey in color. They are typically much lighter in weight than cast resin parts. To assemble 3D printed parts and to attach 3D printed parts to vacformed parts, use cyanoacrylate (Superglue) or 2-part epoxy. Solvent based model cements will not work on resin parts.

### Removing Support Columns:

The 3D printing process uses resin support columns during printing. These supports are made of the same resin as the part. While we remove most supports during the manufacturing process, some parts will arrive to you with supports in place when necessary for parts organization or structural support. In these cases you will need to remove these supports. Carefully remove the supports with sprue cutters, utility knife, or cuticle scissors. Twisting and pulling is likely to damage the part. Depending on the geometry of the part, the supports may leave small dimples on the part surface where they were attached. Lightly wet sand these areas to remove the attach points.



### Removing Layer Lines:

3D printed parts are composed of discrete layers that can be up to 32 microns thick. While every effort is made to minimize the visibility of the layering, you may see small step-marks on the part, particularly on large, smooth, curved surfaces. We recommend that you first prime the part with a high-quality primer. When the primer is dry, wet-sand to even the surfaces. Usually just a few minutes with a wet-dry sandpaper (from 320 to 600 grit) is all that is required. Don't worry, you are unlikely to sand away panel lines or details. On smaller, more detailed parts any visible layering pattern can usually be eliminated with a few coats of a high-quality spray primer.

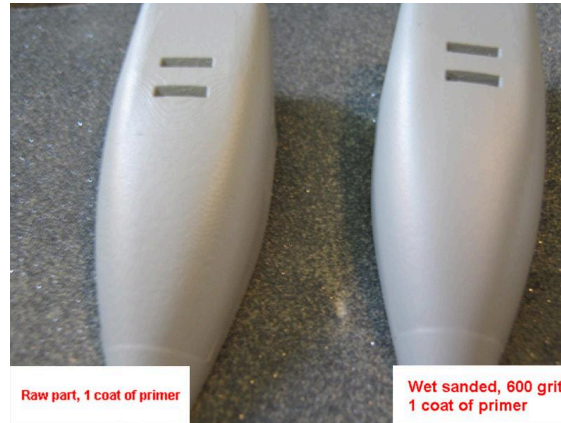

### Opening / Increasing Hole Diameter:

If you need to open or widen a hole, use a grinding (burr-style) bit rather than a drill bit. Drill bits can crack the resin.



### Uncured / Under-cured Resin:

3D printed resin is UV-cured using 405nm light. If you sand deep into a 3D printed part you may expose resin that is not fully cured. In this case, simply place the part outside in sunlight for a few minutes to fully cure the exposed area.



### Troubleshooting Resin Parts:

If you encounter resin parts that are sticky or wet there are two possibilities. The resin may have residue from the cleaning process or the resin may not be fully cured. Wipe the resin part with isopropyl alcohol to remove cleaning residue. If the part is still sticky, place it in direct sunlight for a few minutes.



**Assembly:**

3D printed parts should be glued to one another and to vacformed parts using cyanoacrylate (Superglue or equivalent) or 2-part epoxy.

**Filling gaps:**

Gaps can be filled with scrap styrene, gap-filling super glue, filler putties, or with 2-part plumber's epoxy putty

**Pro Tip:**

The strongest joint is a chemically welded styrene-to-styrene joint—one that is glued with solvent glue. For extremely strong construction use scrap styrene to 'wrap' your wheel wells. This can be done before installing them, or after and can be done for both the main wheel wells and the nose wheel well. The goal is to make a styrene box to contain the resin part and take stress off of the resin-styrene joint. You can also use this technique on cockpit components to help ensure strong construction.





## Decals:



Decals are designed and printed by our partner [DRAWDecal.com](http://DRAWDecal.com) using their Digital Silk technology. The below guidance comes directly from DRAWDecal.com.

Digital Silk decals are extremely durable and do not easily scratch, and are printed on a continuous, clear film. Each design will need to be cut out individually. Digital Silk decals do not generally need to be clear coated prior to use. Use care when applying as the decal film is extremely thin.

Digital Silk decals are tough and durable, but do not like to bend around corners. To get the decals to flex or bend, an easy solution is to soak the decal in VERY HOT water. The HOT WATER softens the ink and allows the decal to conform around tails and over uneven surfaces. DO NOT float the decal off of the paper, as it will fold over itself and become unusable. Rather, soak the decal in very HOT water for about 45 seconds then remove it and allow it to sit for 15 seconds before trying to slide it off of the backing paper.

"Normal" decal setting solutions can be used with these decals. We recommend using Microscale's Micro Set (a wetting agent) and Micro Sol (a SOLvent), but note the decal solvents only affect the clear film and have LITTLE TO NO effect on the inks. Brush the Micro Set directly on your model before sliding the decal into position. After you slide the decal into position and soak up the excess liquid, apply a thin coat of Micro Sol (the solvent) to soften the clear carrier. It is important to get the Micro Sol under the decal, as the solvent has little effect on the ink, but it will dissolve the clear carrier which allows the decal to dig into the paint. After this coat dries and you are certain the decal is in its final position, apply a second heavier coat of Micro Sol.

Another method to try is to use a cloth soaked in HOT water to press the decal into place over rivets, panels lines and other contours. Just a reminder, HEAT is the best option to make the ink bend and conform.

After the decals are completely dry, clear coating your model after applying these (or any) decals is a must! I repeat this is a must. The clear coat will seal your decal and prevent it from becoming damaged. Airbrush lacquers only in very light, misting coats. Another method to clear coat the decal is to use Future acrylic floor polish. Good luck and thank you for using Digital Silk decals!

### How to Apply DRAW Decals

- All of our decals are printed in our proprietary Digital Silk process with two exceptions. The Hellcat sets are ALPS printed because they contain metallic gold elements. The other exception is the Ford Trimotor sets, as they are both ALPS and LASER printed because of the corrugated surface of the kits. All of our decals are printed on the same high quality decal paper, and they apply just like any other thin-filmed decal.
- Digital Silk decals are extremely durable and do not easily scratch. They do not generally need to be clear coated prior to use.
- We STRONGLY recommend clear coating the Laser and ALPS printed decals before applying. The clear coat prevents scratching the ALPS decals and prevents the toner from debonding from the Laser

decals. We recommend using a very light coat of Future or Micro Scale Scale Liquid Decal Film applied with a q-tip swab to coat the decals.

- Use care when applying as the decal film is extremely thin. DO NOT float the decal off of the paper, as it will fold over itself and become unusable. Rather, soak the decal in tepid water for about 5 seconds then remove it and allow it to sit for 45 seconds before trying to slide it off of the backing paper.
- The ALPS decals are more "soft" than a regularly silk-screened decals. While they will stand up to normal handling, they will easily scratch. The Laser decals will not stand much flexing which results in the toner debonding from the decal paper. Use care to ensure you do not damage your decal.
- Digital Silk decals are tough and durable, but do not like to bend around corners. An easy solution is to soak the decal in hot water. This softens the ink and allows the decal to conform around tails and over uneven surfaces.
- Clear coating your model after applying these decals is a must! I repeat this is a must. The clear coat will seal your decal and prevent it from becoming damaged. DO NOT BRUSH ON ANY CLEAR LACQUER over these decals, as they will instantly dissolve. Airbrush lacquers only in very light, misting coats. Another method to clear coat the decal is to use Future acrylic floor polish. Yes, you heard right, see for yourself in [everything you ever wanted to know about Future including where to find it outside of the US](#).
- "Normal" decal setting solutions can be used with these decals. I recommend using Microscale's Micro Set and Micro Sol solutions. Brush the Micro Set directly on your model before sliding the decal into position. After you slide the decal into position and soak up the excess liquid, apply a thin coat of Micro Sol (the solvent) to soften the decal. After this coat dries and you are certain the decal is in its final position, apply a second heavier coat of Micro Sol. For really stubborn areas where the decal is not adhering to the model, you may apply a very light coat of Walthers Solvaset; use caution as this is a very strong solvent and will "liquefy" the decal until it dries. DO NOT touch the decal until it is dry!!

To summarize, here are my 10 steps to decaling successfully: (After making sure all cat hair is removed)

1. Cut out the decal with scissors, not a straight edge and razor knife. While the Digital Silk decals are tough and durable, Laser and ALPS decals are delicate and will easily scratch or flake.
2. Wet the area on the model BEFORE sliding on the decal. Use either tepid water or Micro Set (the one with the blue label).
3. Dip the decal in water for only 5-10 seconds, remove it from the water and let it sit on your table for about a minute. DO NOT let the decal float off of the backing paper.
4. Pick up the decal with self-locking tweezers, get it in position over the model, hold the decal in place with either your finger or a soft brush, then pull away the backing paper letting the decal gently drop into place.
5. Adjust the decal position with the brush, apply more water or Micro Set if the decal is hard to move around.
6. Once the decal is in position, let it dry on its own, DO NOT MESS WITH IT unless it is in the wrong position.
7. After the decal is dry AND you are sure it is in the right position, then apply your decal solvent of choice: Micro Sol or Solvaset.
8. Absolutely positively do not touch the decal until it is dry, as the ink is wet and will smear which will ruin the decal.
9. Once the decal is dry, clean up any residue with a Q-tip (swab) soaked with water and mild dish detergent.
10. Apply your clear coat of choice to seal the decal. Do not skip this step!!! This is critical.

I hope these steps help, and remember a good decal job does not look like a decal at all!

"It's Really Quite Easy"

## Clear Parts:

Clear parts are made from vacuum formed plastic. They are formed using ultra-high-resolution 3D-printed molds using the same CAD data as the rest of the model to ensure accurate fit.

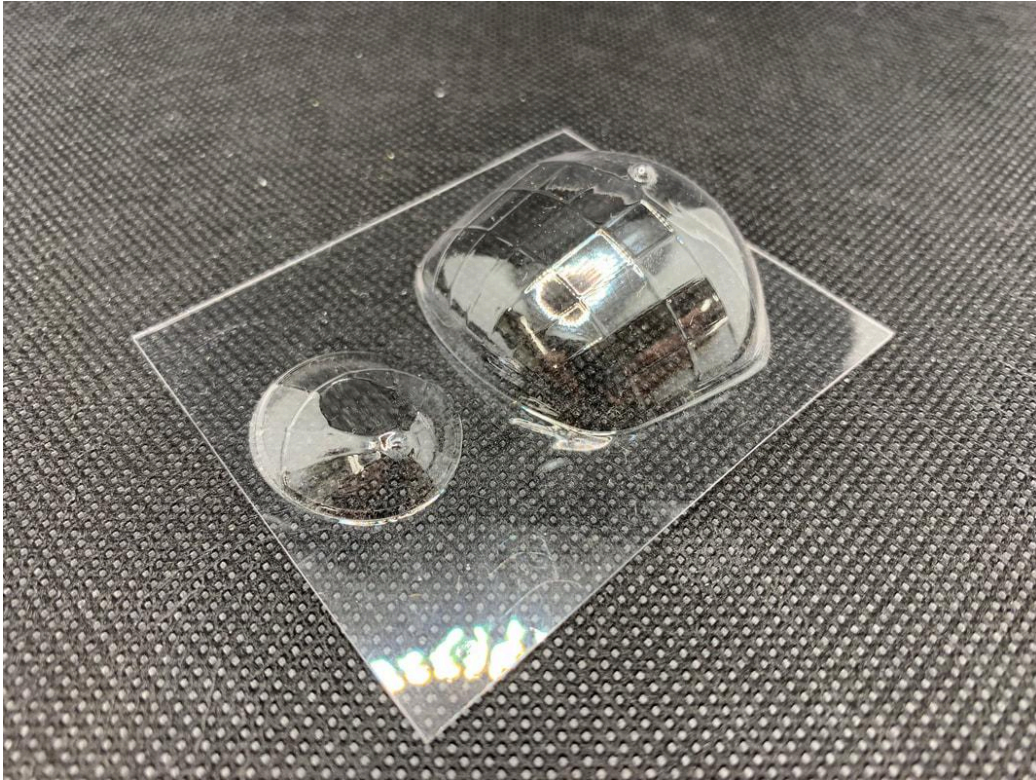

## Kit-Specific Guidance:

### Vacform Parts to Cut Out:

The below screenshot uses the CAD design of the wing vac tooling to show where to cut. Your cut lines are the outer edges of the almond-colored areas.

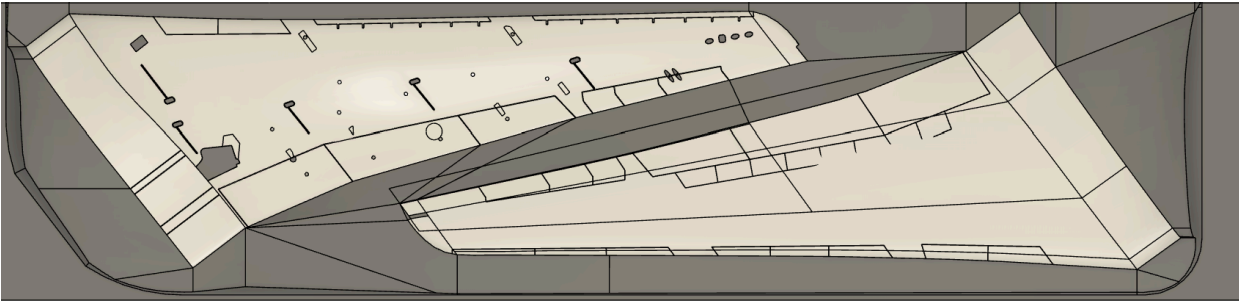

### Resin Part Cutout Locations:

Only the aft nose gear doors are open on the A380 during normal operations. Use the panel lines on the model as a guide to remove the desired material. *Always check and re-check fit against the resin wheel wells to avoid removing too much material.* There is a 'lip' on the resin wheel well that is designed to fit into the door opening that you've cut.

### Nose Gear Door Cutout





### **Main Gear Door Cutouts**

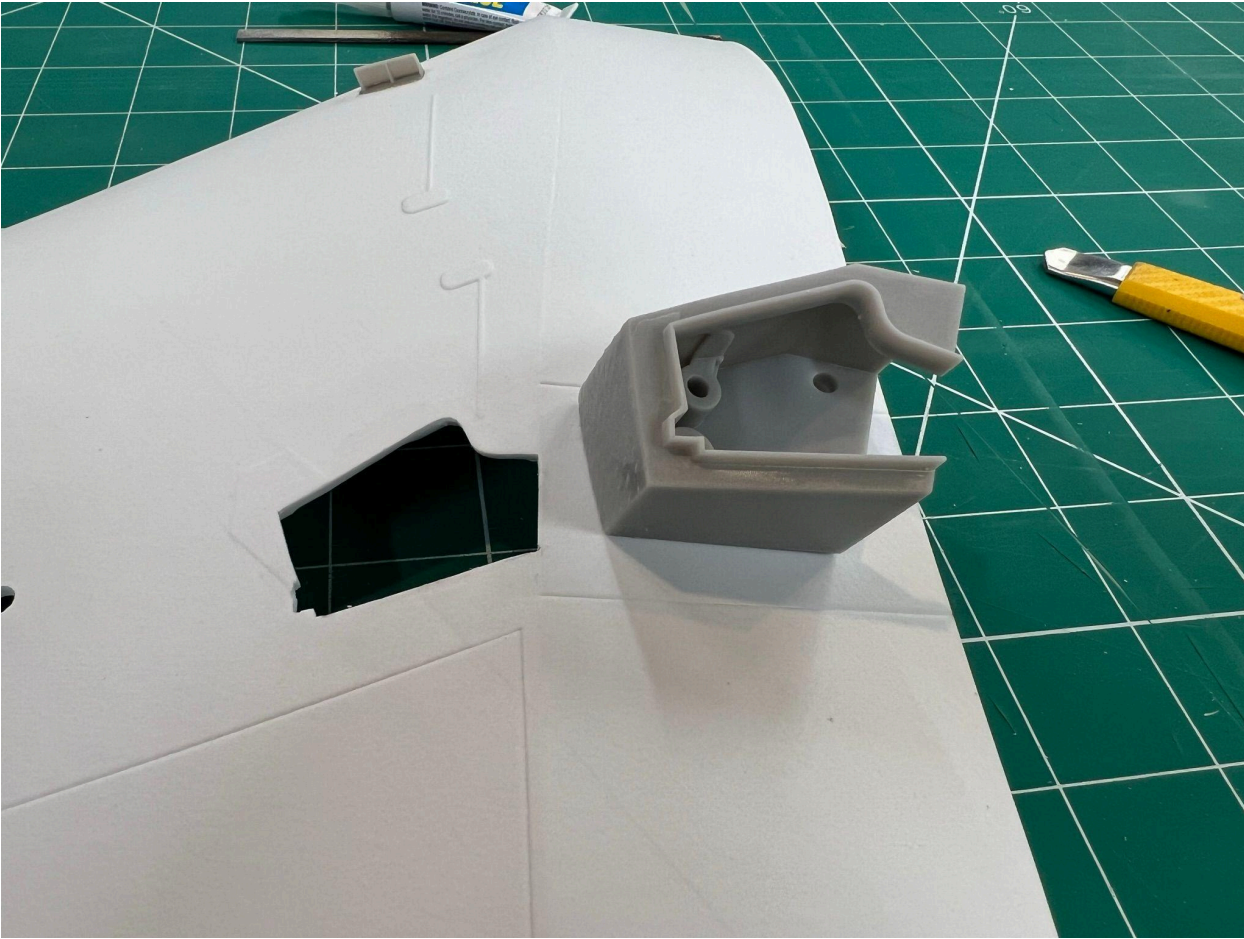

**Nose Weight:**

**Resin Subassemblies:**

**Installing Resin Surface Details:**

Ram air outlet doors in open position (optional)





### **Installing Subassemblies:**

### **Installing Styrene Angle Strips:**

1/4" styrene angle strips are provided to add rigidity to the fuselage and to increase the area of the fuselage joint for glue-up. Install as shown below. Install on BOTH fuselage halves. You may wish to add additional bracing or joint reinforcement using scrap styrene at your discretion.

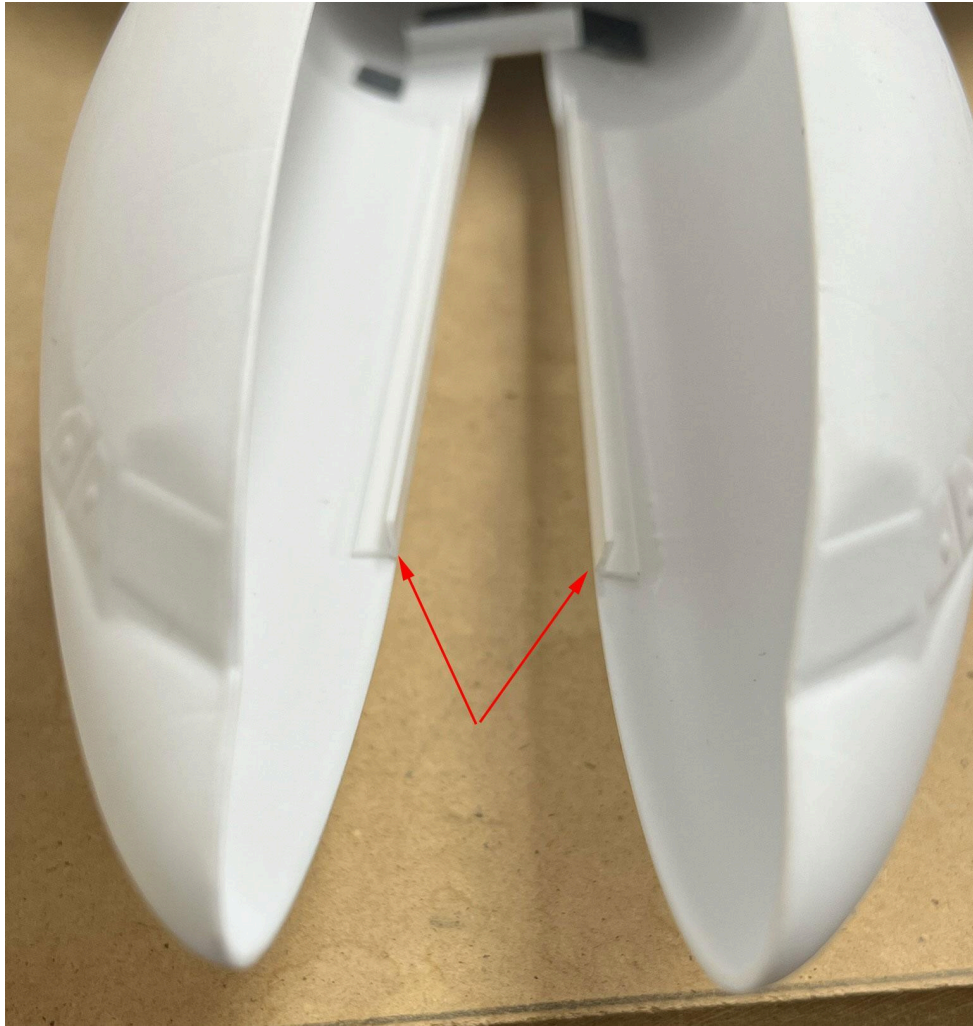

\*concept is illustrated with a photo from the A330 kit but the procedure is the same here

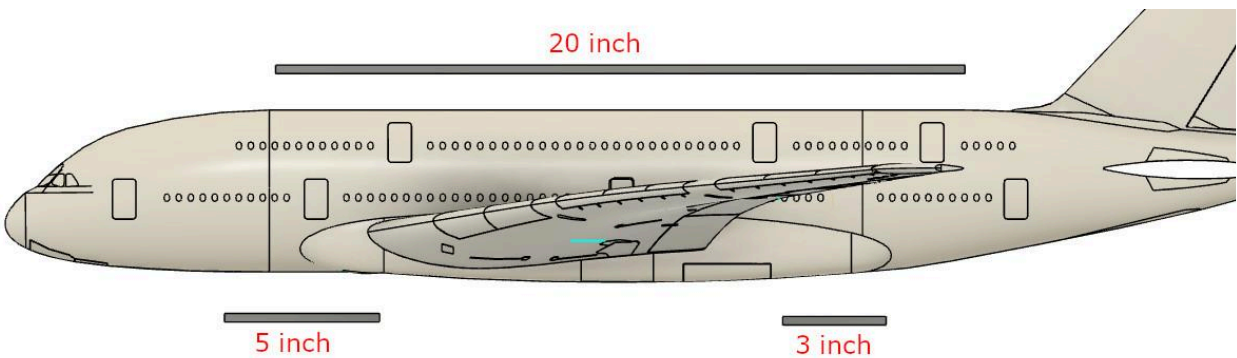

**Pro Tip:** Install the styrene angle just slightly proud of the edge of the fuselage halves. This will ensure that the angles come solidly into contact with one another when gluing the fuselage halves together.



**Assembling the Fuselage Halves:**

**Assembling the Wings:**

**Assembling the Tail:**

**Mating Fuselage, Wings, and Tail:**

**Installing Flap Track Fairings:**

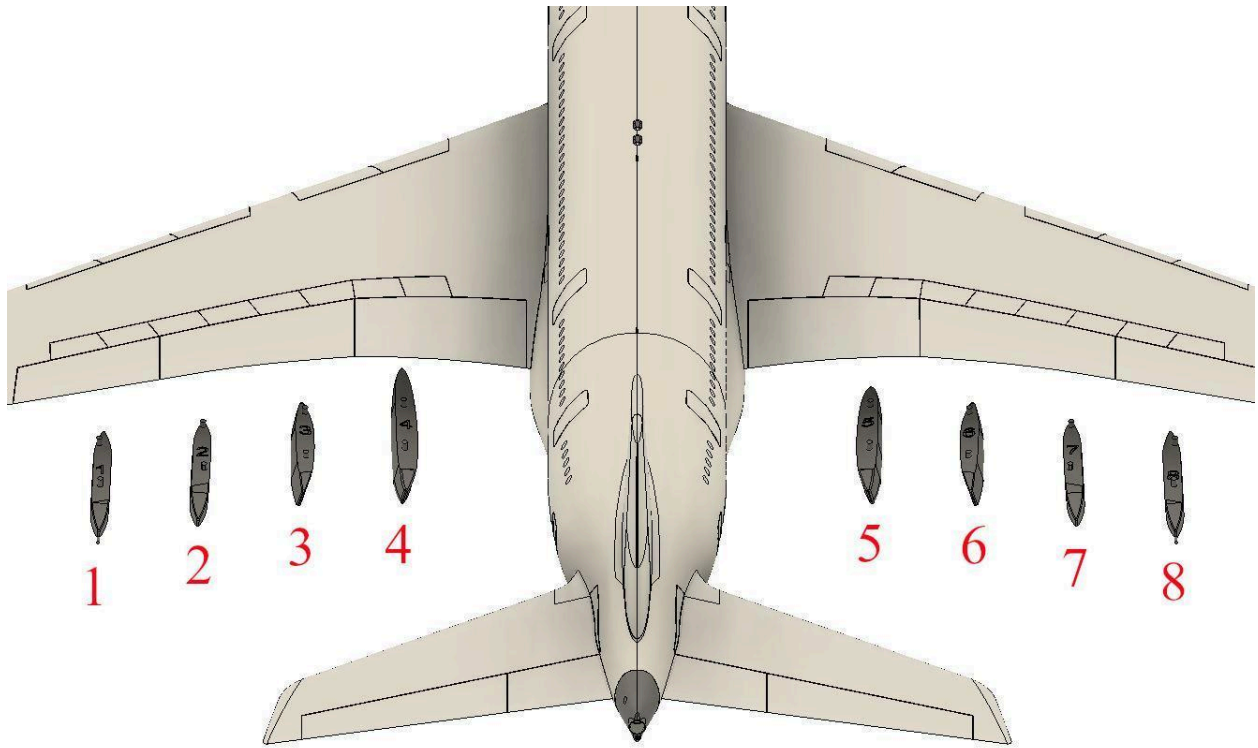

Note that the flap track fairings on the A380 are angled to follow the curvature of the wing

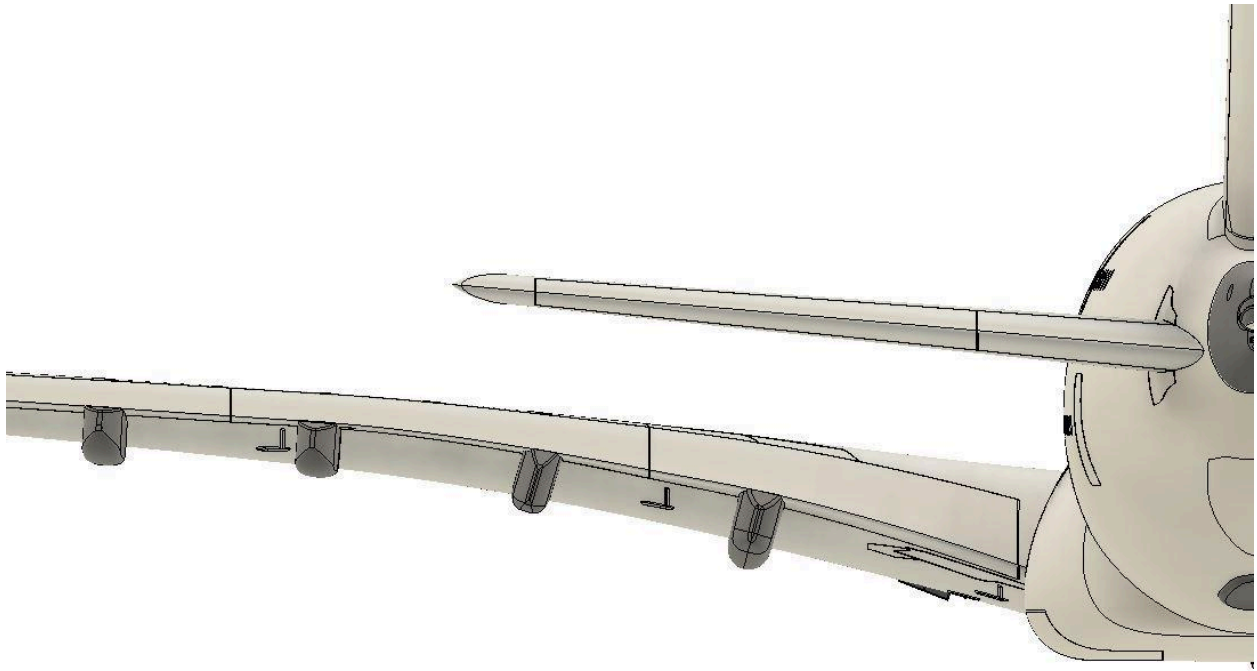

**Installing Engines:**

Assemble each engine and attach to wings using cyanoacrylate glue or 2-part epoxy. Note that wing-mounted engines on most airliners are toed-in slightly rather than parallel to the fuselage. This toe-in angle is built into the kit parts but care should be taken during installation not to accidentally straighten them when mounting to the wings.

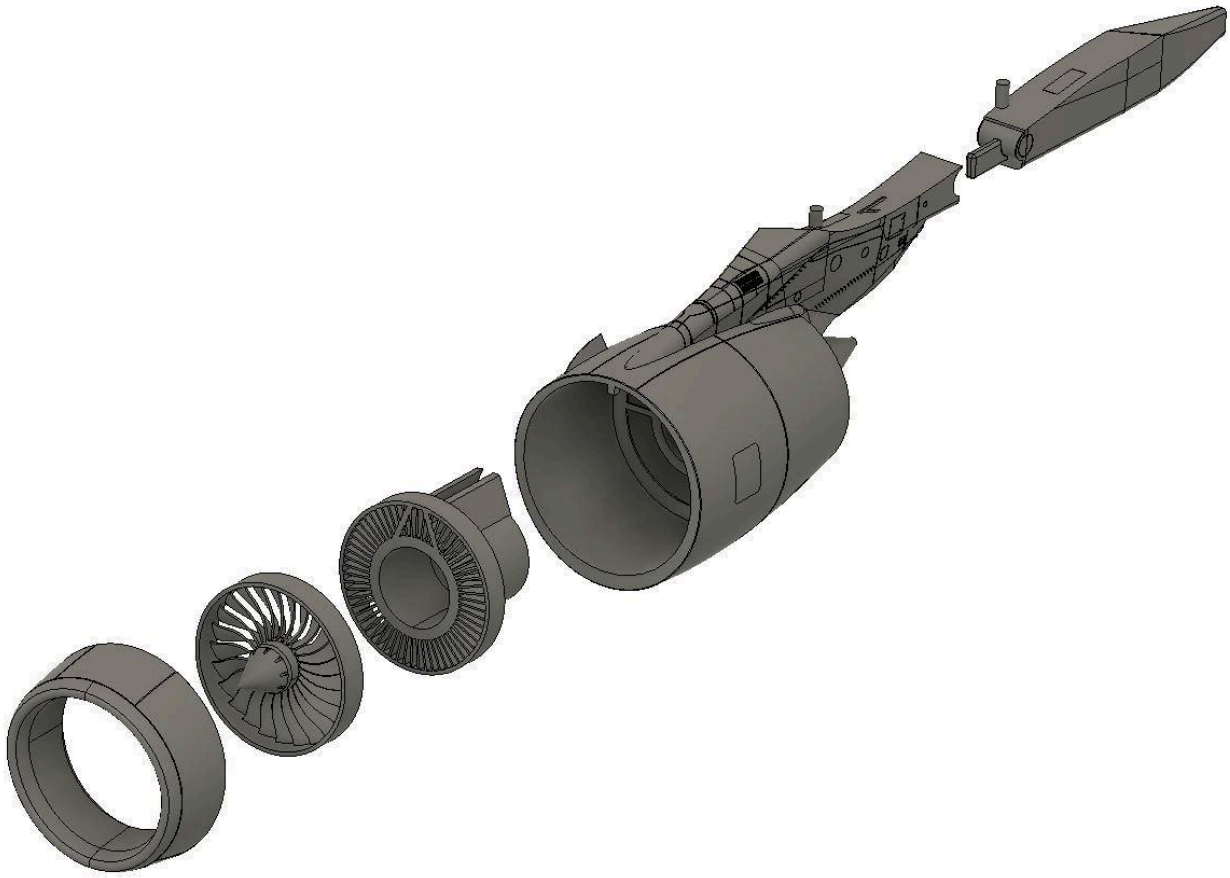

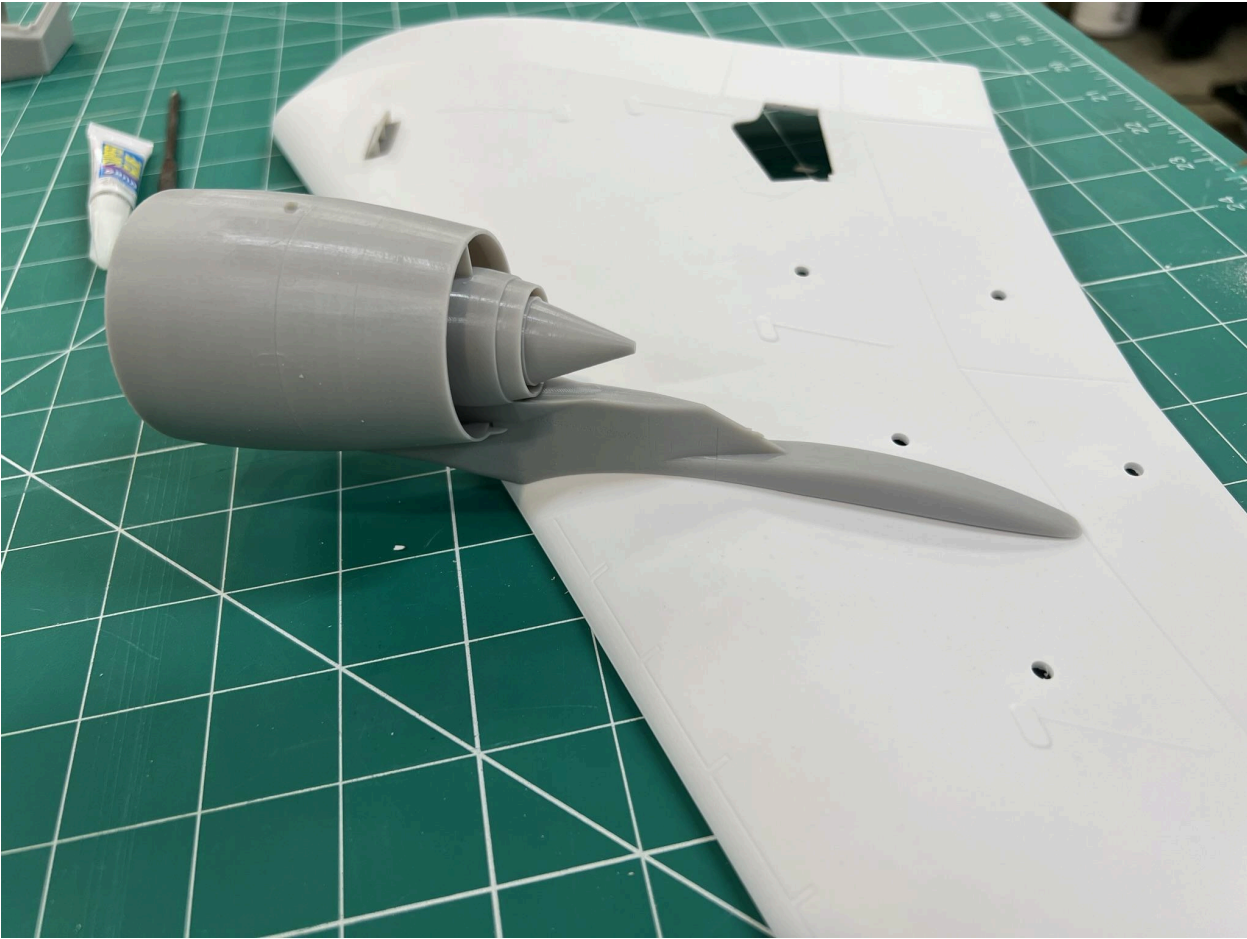

**Installing Additional Resin Details:**

Tailcone / APU Exhaust:

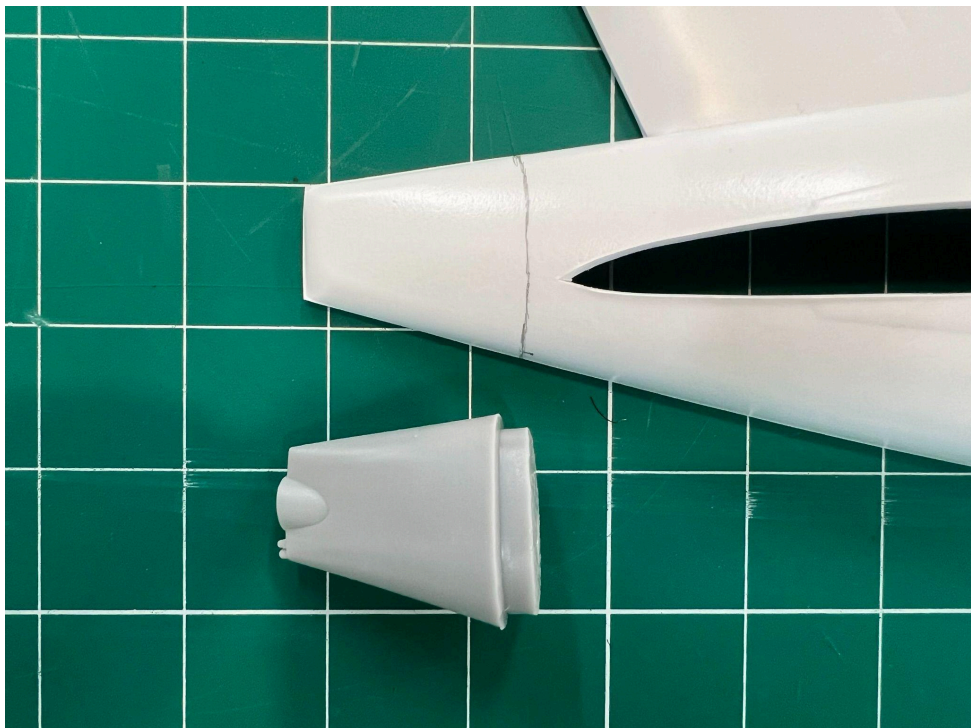

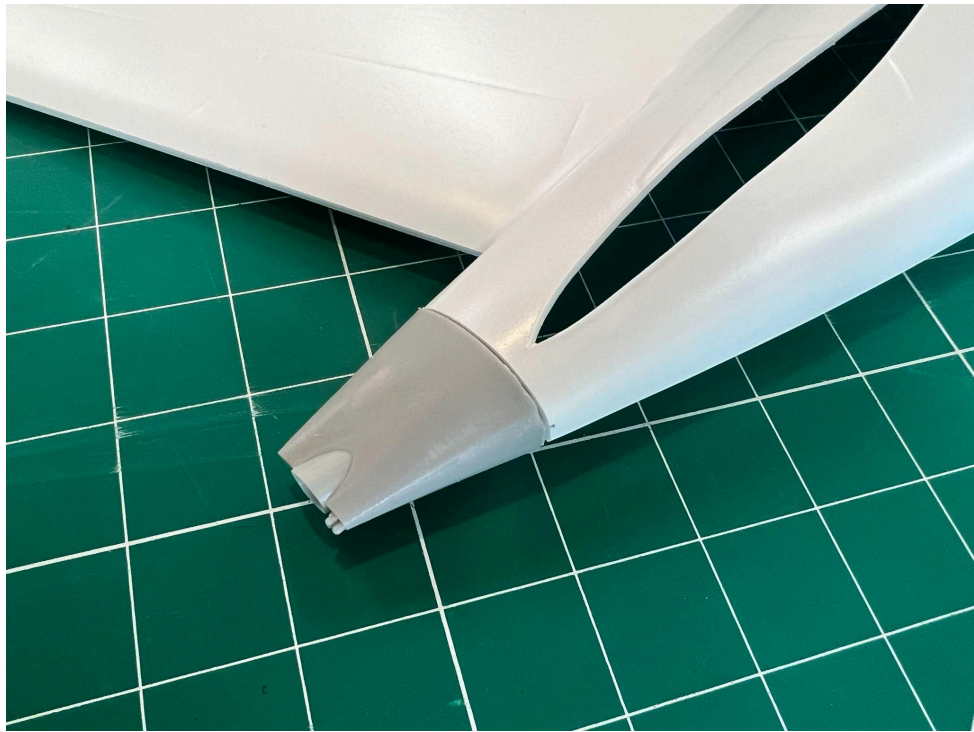

Winglets:

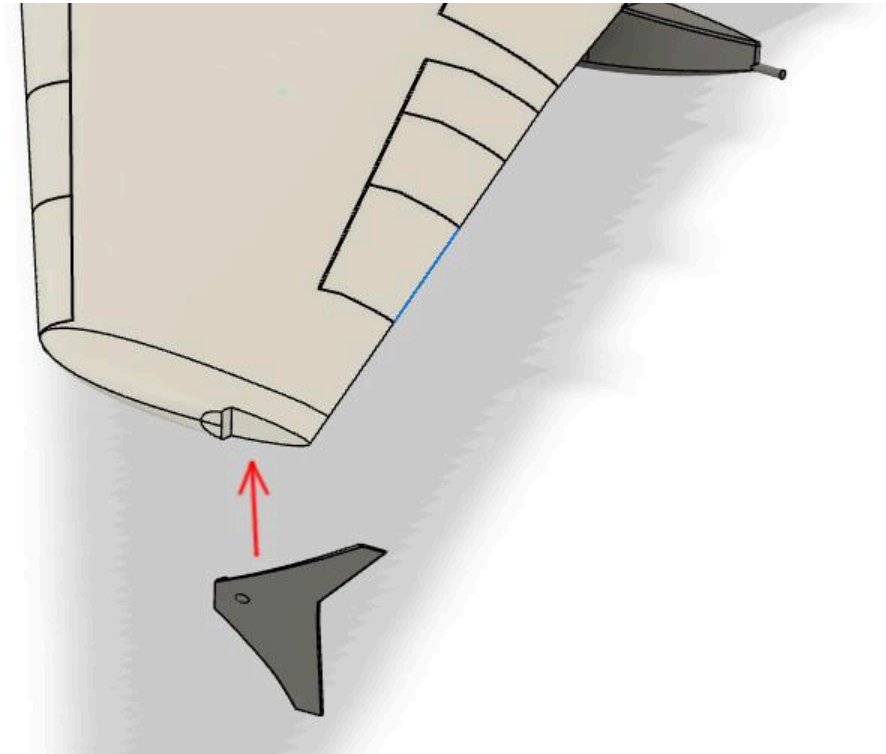

**Installing Clear Cockpit Windows:**

**Antenna Installation Positions:**

## Decals & Paint:



## References and Resources:

[https://en.wikipedia.org/wiki/Airbus\\_A380](https://en.wikipedia.org/wiki/Airbus_A380)

[https://www.cybermodeler.com/aircraft/a-380/a-380\\_walk.shtml](https://www.cybermodeler.com/aircraft/a-380/a-380_walk.shtml)

<https://airlinercafe.com/walkaround/airbus-a380/>

## Record of Revisions:

Revision:	Date:	Notes:
Original	12-15-2024	

## Parts List:

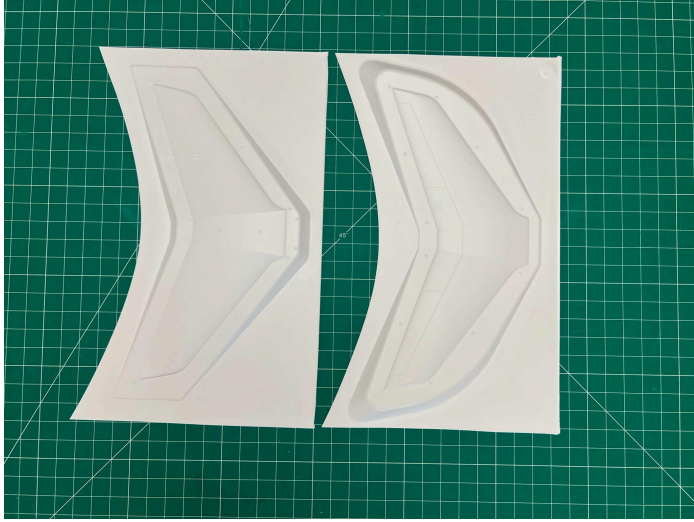

1x Vacform Horizontal Tail Top  
1x Vacform Horizontal Tail Bottom

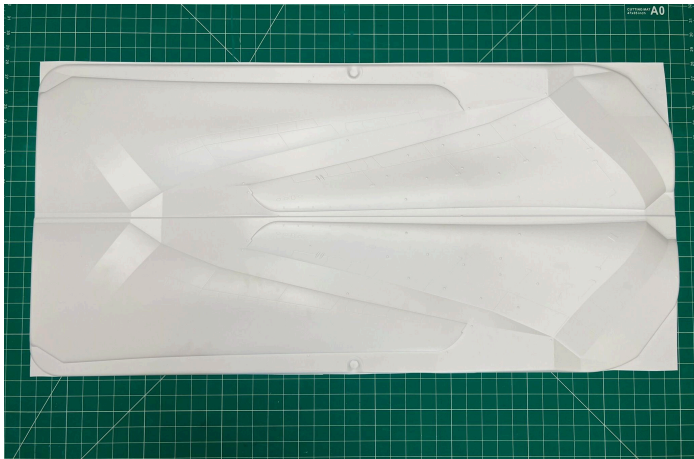

1x Vacform Port Wing Top  
1x Vacform Port Wing Bottom  
1x Vacform Starboard Wing Top  
1x Vacform Starboard Wing Bottom

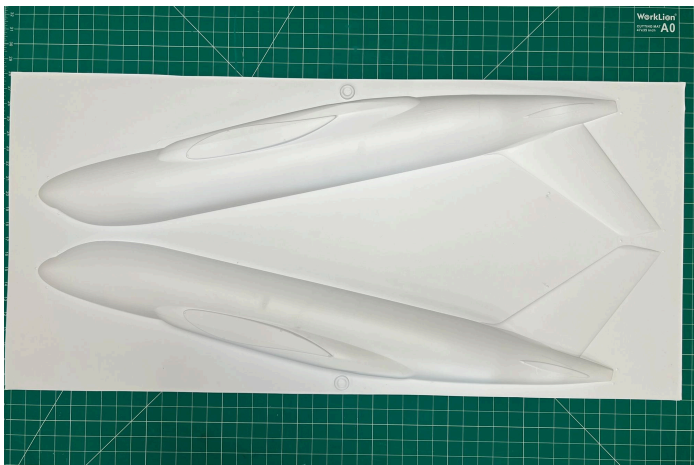

1x Vacform Port Fuselage  
1x Vacform Starboard Fuselage

Angle Styrene Strips



1x Port Body Wheel Well  
1x Starboard Body Wheel Well



1x Port Wing Wheel Well  
1x Starboard Wing Wheel Well  
1x Nose Wheel Well



2x Body Gear  
1x Port Wing Gear  
1x Starboard Wing Gear  
1x Nose Gear

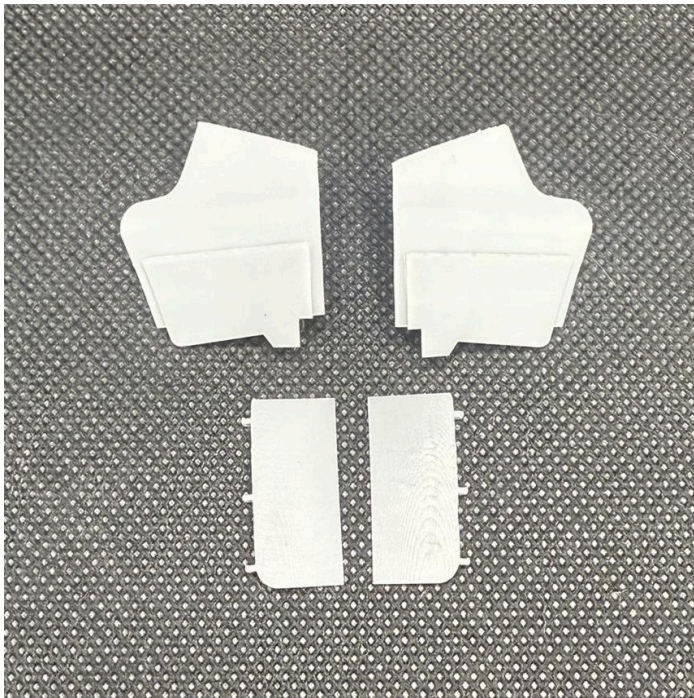

1x Port Main Gear Door  
1x Starboard Main Gear Door  
1x Port Nose Gear Door  
1x Starboard Nose Gear Door

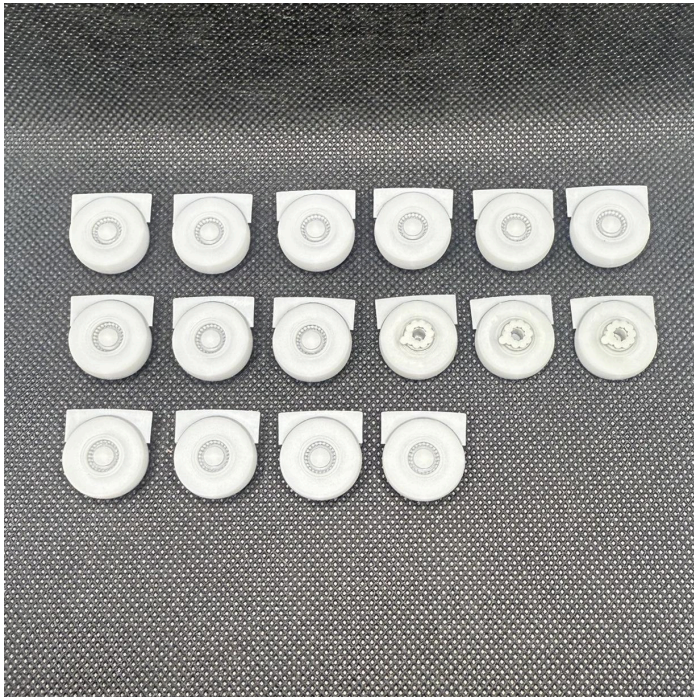

16x Main Wheel With Brake Assembly

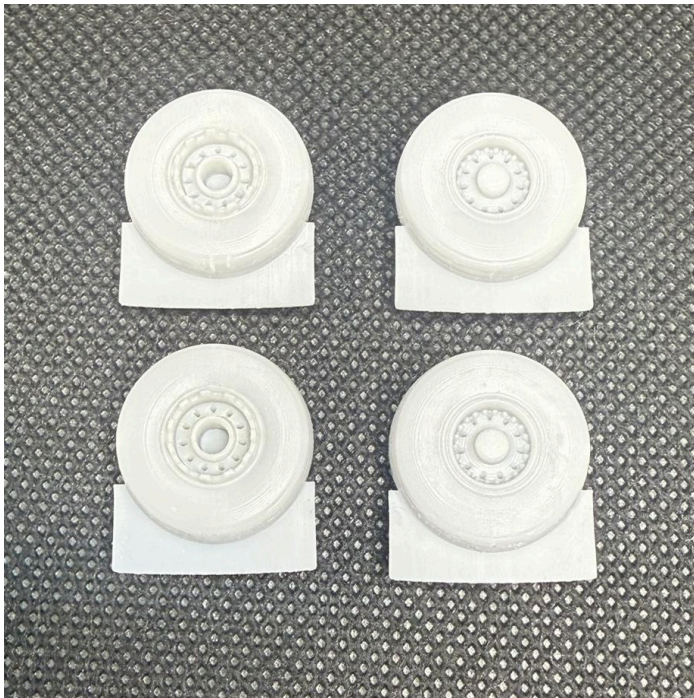

4x Un-braked Main Wheel

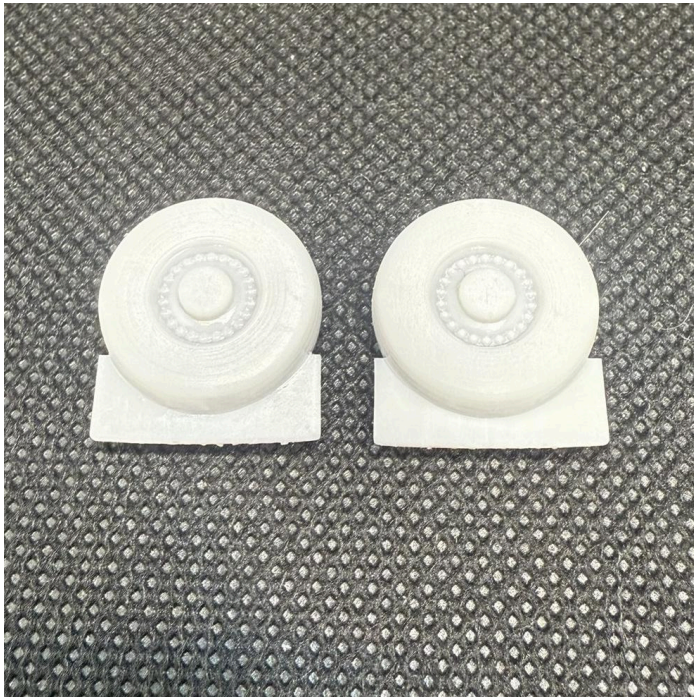

2x Nose Wheels

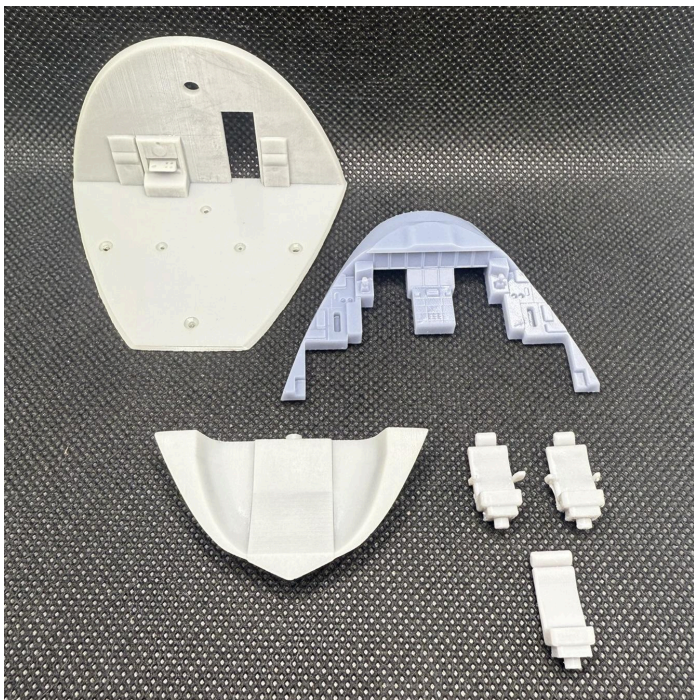

1x Cockpit Floor  
1x Cockpit Overhead  
1x Forward Instrument Panel  
1x Pilot Seat  
1x Copilot Seat  
1x Observer Seat



1x Tailcone with APU Exhaust

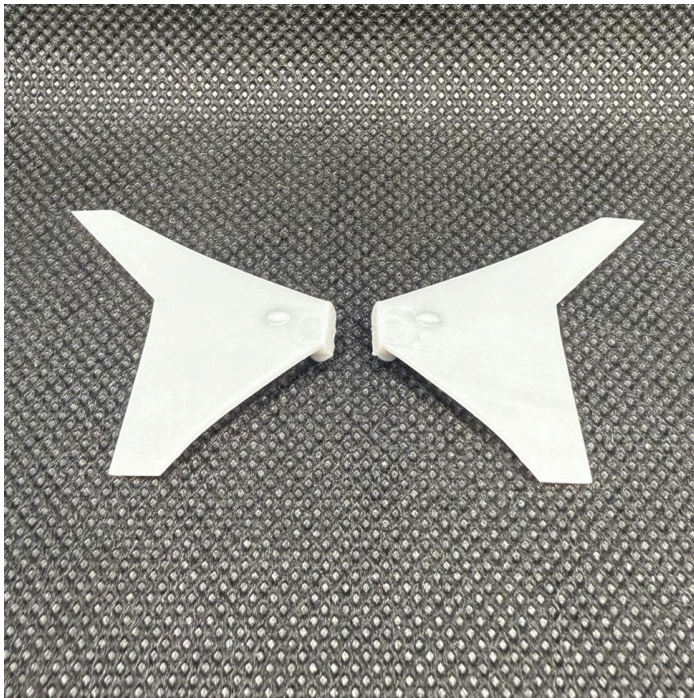

1x Port Winglet  
1x Starboard Winglet





1x Port Belly Intake  
1x Starboard Belly Intake

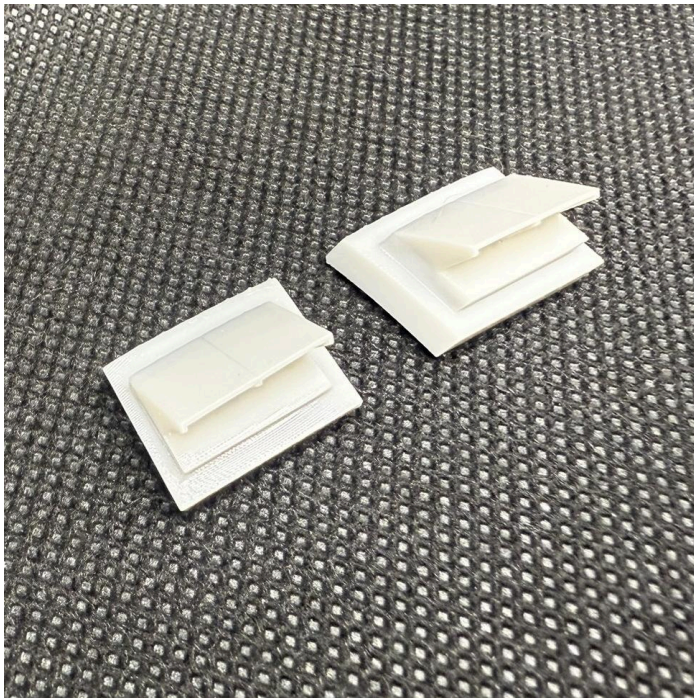

1x Port Ram Air Outlet Doors  
1x Starboard Ram Air Outlet Doors



1x Port Wing Root Fairing  
1x Starboard Wing Root Fairing



1x Flap Track Fairing 1  
1x Flap Track Fairing 2  
1x Flap Track Fairing 3  
1x Flap Track Fairing 4  
1x Flap Track Fairing 5  
1x Flap Track Fairing 6  
1x Flap Track Fairing 7  
1x Flap Track Fairing 8

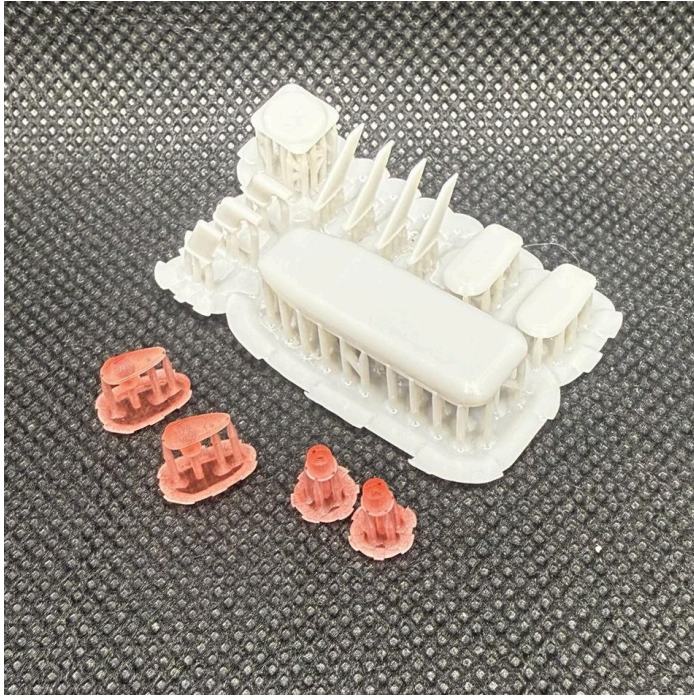

1x Antenna Set  
2x Teardrop Beacon Light  
2x Cone Beacon Light

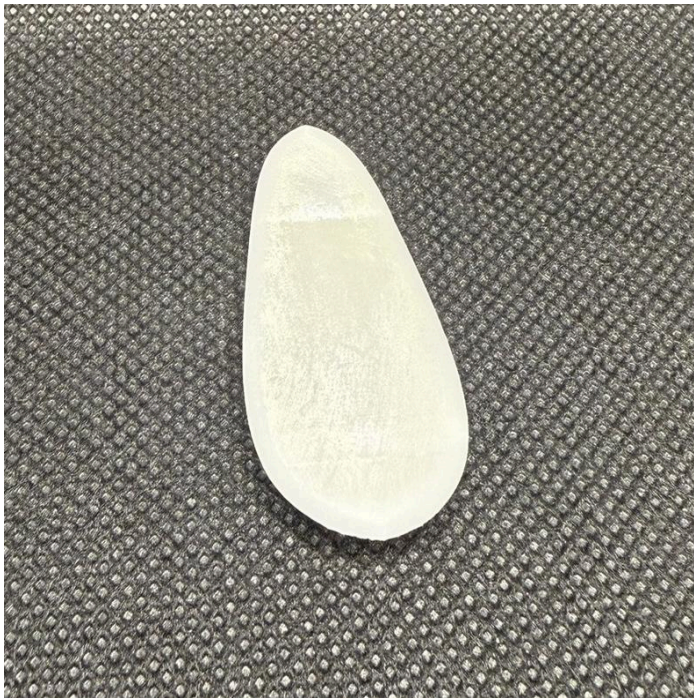

1x Tail Skid



1x Engine 1 Aft  
1x Engine 2 Aft  
1x Engine 3 Aft  
1x Engine 4 Aft



4x Intermediate Engine Internal



1x Engine 1 Aft Fairing  
1x Engine 4 Aft Fairing



4x Engine Cowl Front



4x Engine Fan (Trent 900 Option)

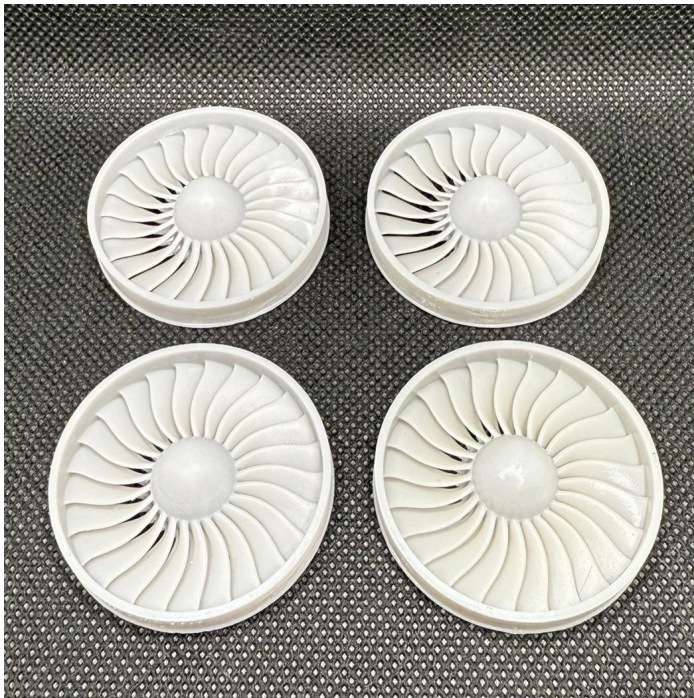

4x Engine Fan (GP7200 Option)

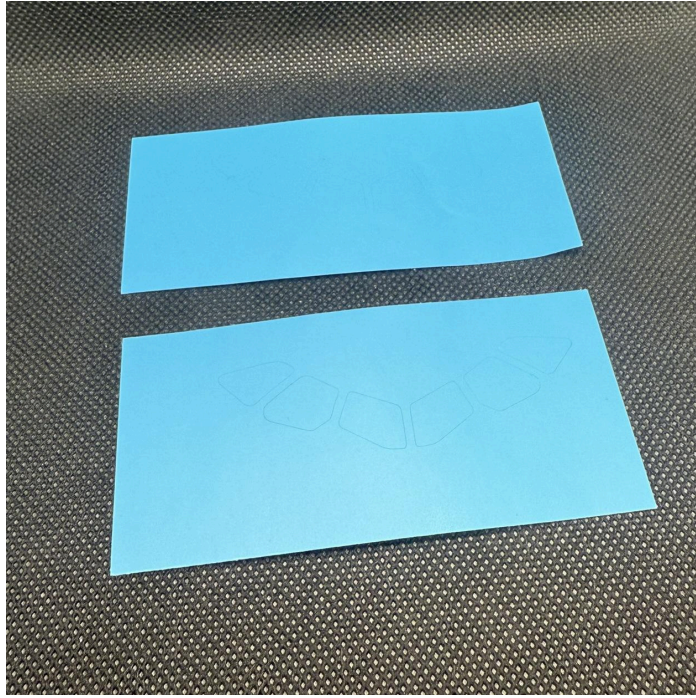

2x Cockpit Window Adhesive Masks

2x Cockpit Window Transparencies