

F3H-2 DEMON

SW 72122

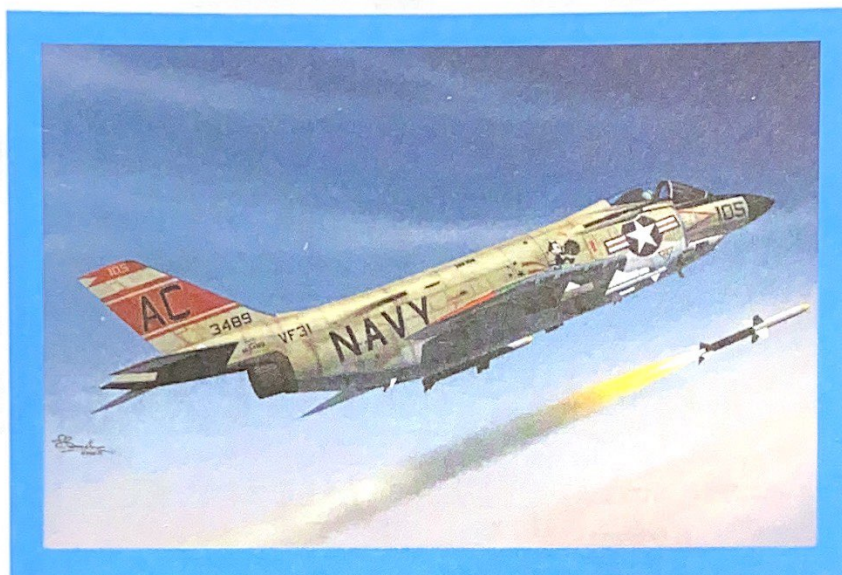

Development began in 1949 for a carrier-based jet fighter. The swept-wing design was to be powered by a single Westinghouse J40, the U.S. Navy's preference at that time, and a departure from McDonnell's usual twin engine layout. The Navy needed a jet fighter to combat the Mig 15 over Korea and ordered the F3H into production even before the prototype FX3H-1 had made its first flight in August 1951. But the J40 was problematic. Lack of power limited the Demon to sub-sonic speed except for in a shallow dive. The first operational design appeared in 1953, too late for the battle. Engine problems and accidents meant the grounding of the Demon. A J40 powered Demon did however break an unofficial time-to-climb record; 10,000ft (3000m) in 71seconds. Other J40 powered aircraft projects were either shelved or redesigned to be fitted with other engines. The J40 program was itself shelved in 1953. The demon could not be fitted with most of the other engines available without major changes to wings and fuselage. The best option was the Allison J71, the F3H then becoming the F3H-2N. This engine also proved problematic in service; insufficient power, flameouts, compressor-stalls. This version was first flown in 1954, but by then the aircraft also had other problems. An additional order of 239 F3H-2 was however, deployed in 1956. The Demon was retired in 1964. 519 had been built. An F3H-P recon version had been designed, but never built. Armament consisted of 4 x 20mm (0.79 in) colt Mk 12 cannons, the 2 upper cannons later removed to save weight. The F3H-2M carried Raytheon AAM-N2 Sparrow, and later, Sidewinder missiles. Deployed aircraft would carry both; Sparrows on the inboard mounts, Sidewinders on the outer. Carrier defence omitted the cannons unless installed and armed for specific task such as the 'Cuban missile Crisis'.

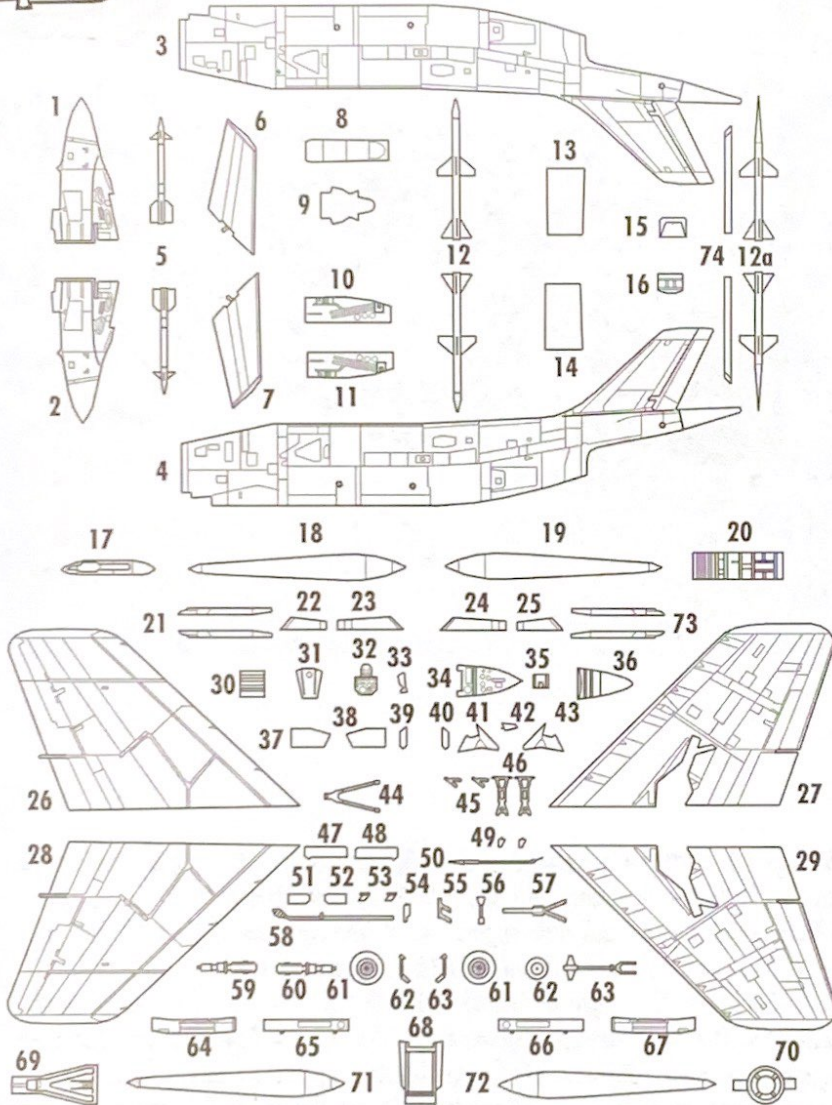

CLEAR



PHOTO-ETCHED

URETHAN

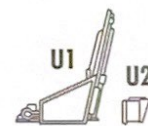

BARVA/COLOR

- (A) Černá/Black
- (B) Khaki
- (C) Stříbrná/Silver
- (D) Hliník/Aluminium
- (E) Světle šedá/Light Grey
- (F) Bílá/White
- (G) Žlutá/Yellow
- (H) Zelená/Green
- (I) Černošedá/Tyre Black
- (J) Špinavý hliník/Dirty Aluminium
- (K) Chromová/Chrome
- (L) Burn Iron/Vypálený kov
- (M) Kovová/Gun metal
- (N) Přírodní kov/Natural metal
- (O) Červená/Red

STEP 1

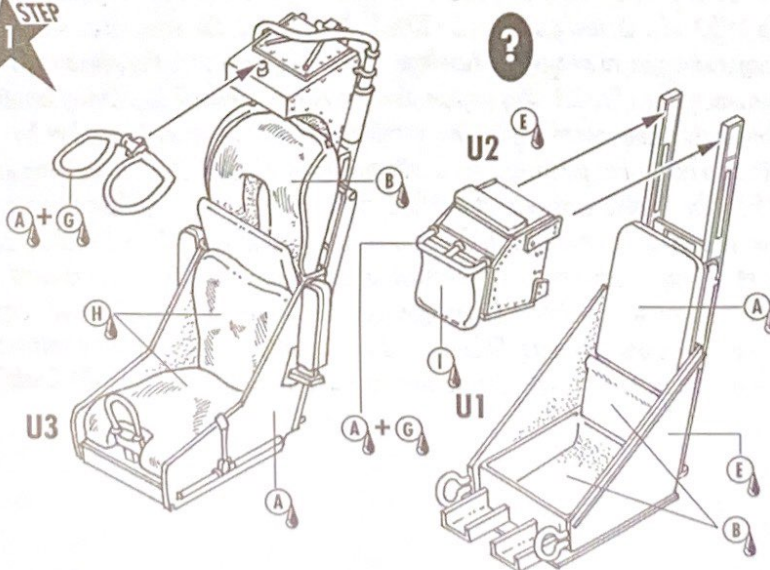

STEP 2

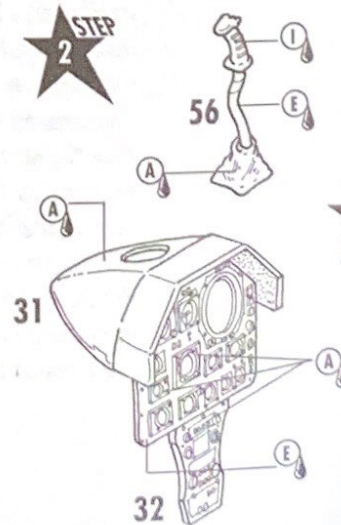

STEP 3

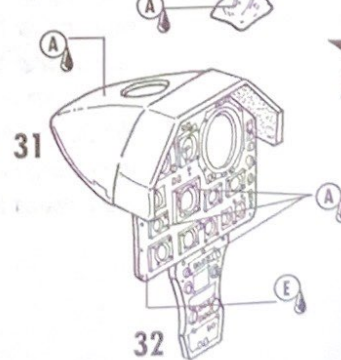

STEP 4

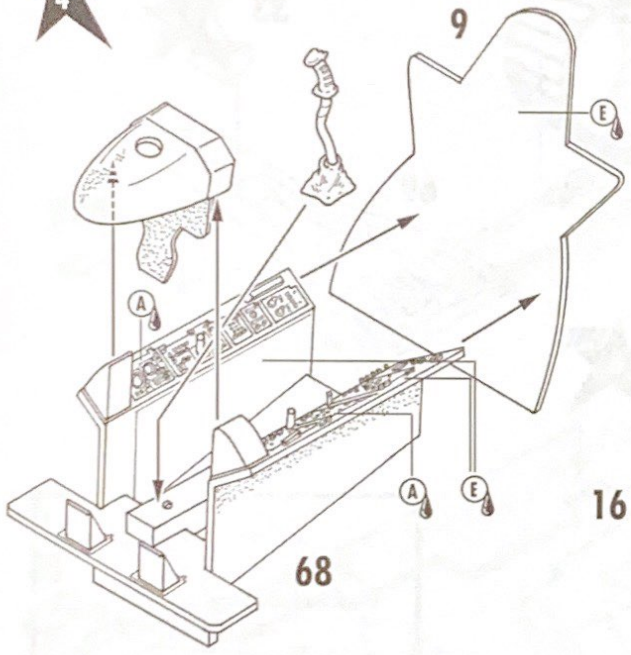

STEP 5

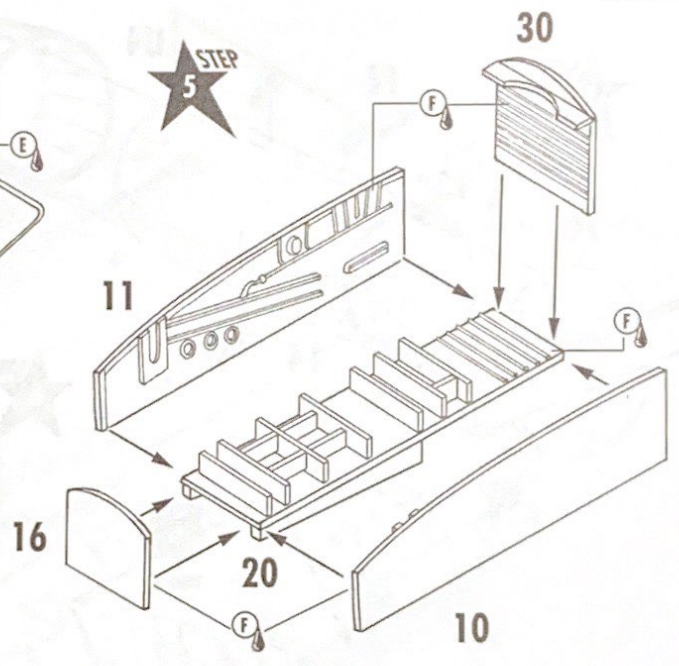

STEP 6

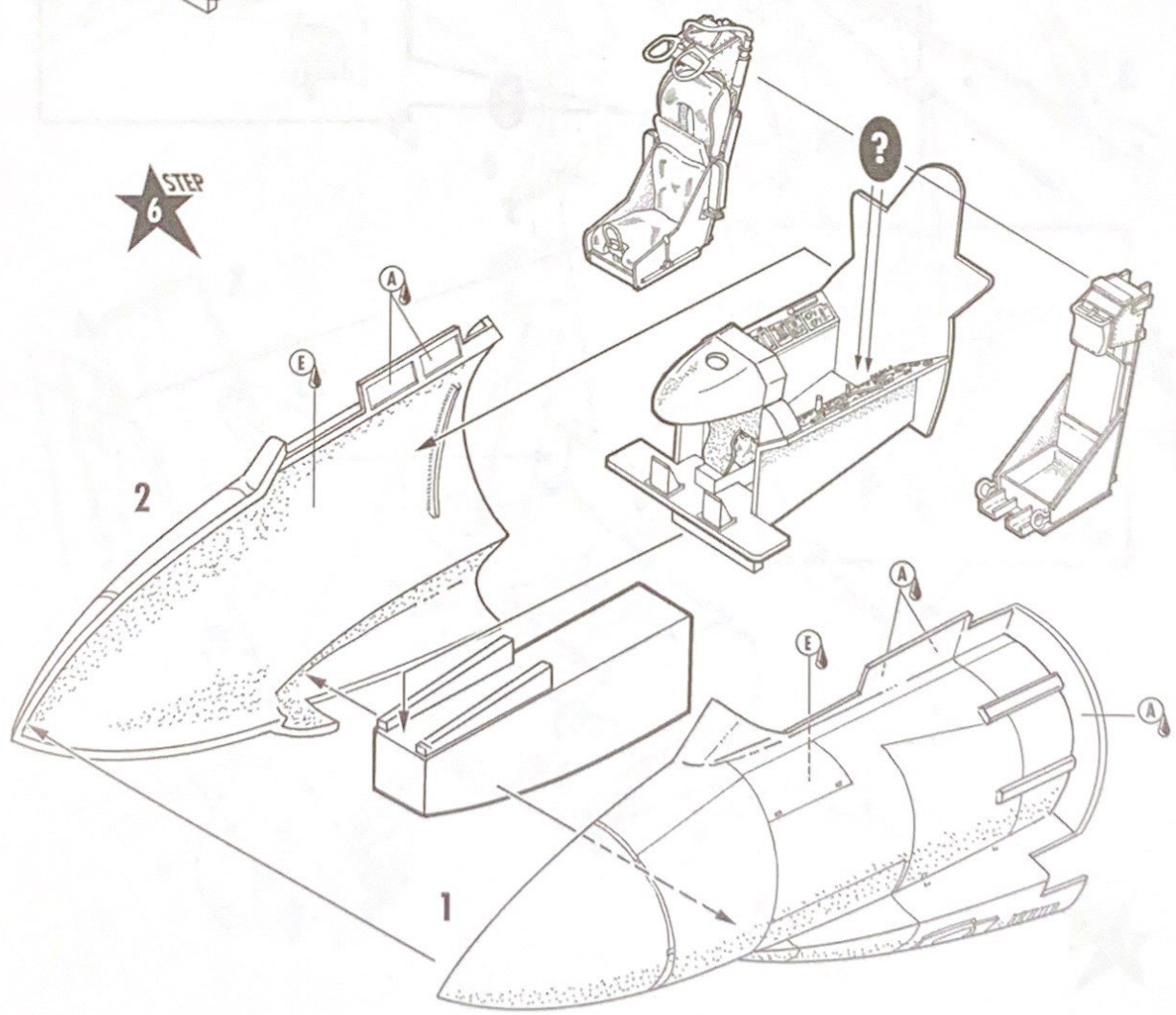

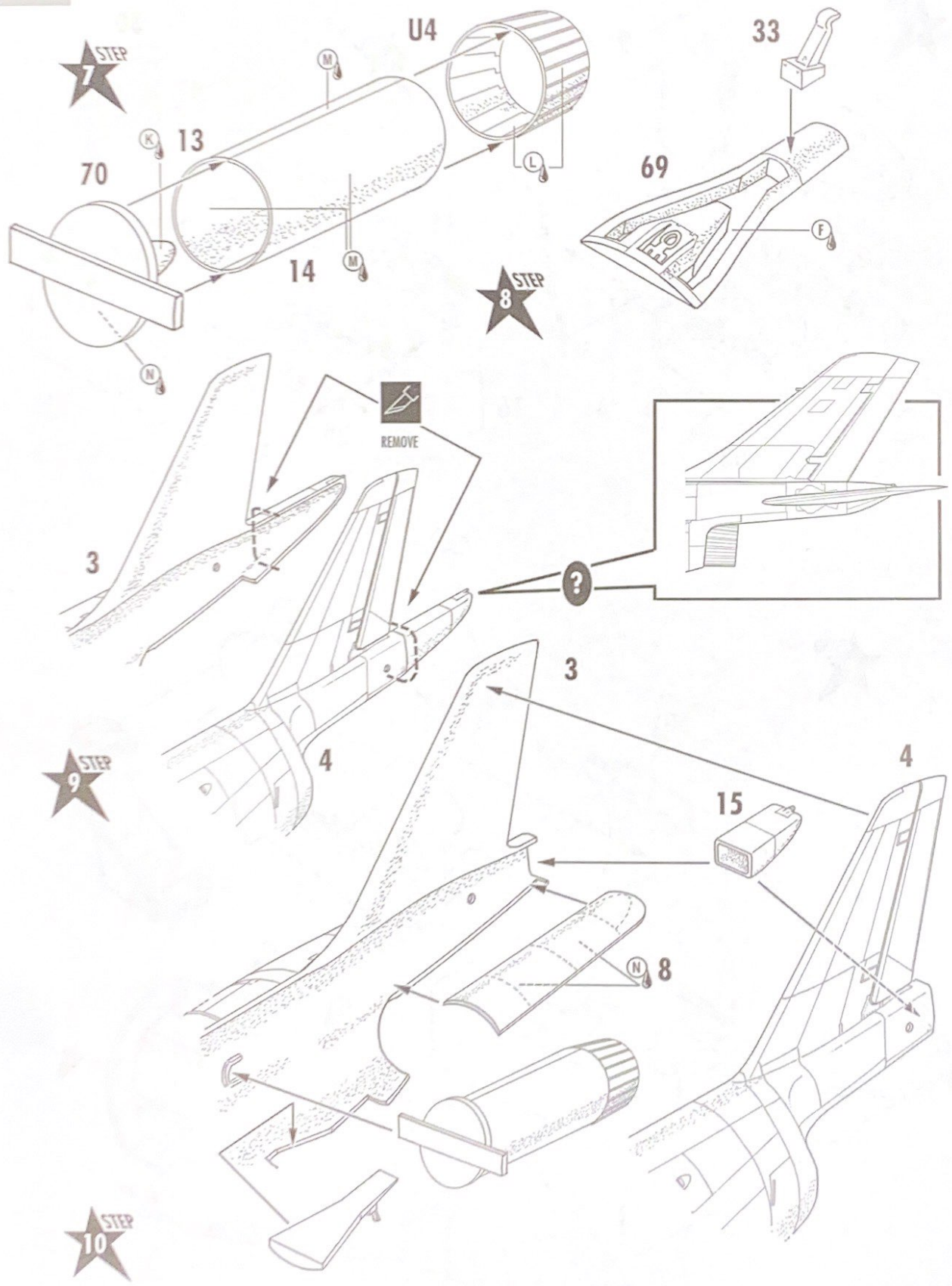

STEP 11

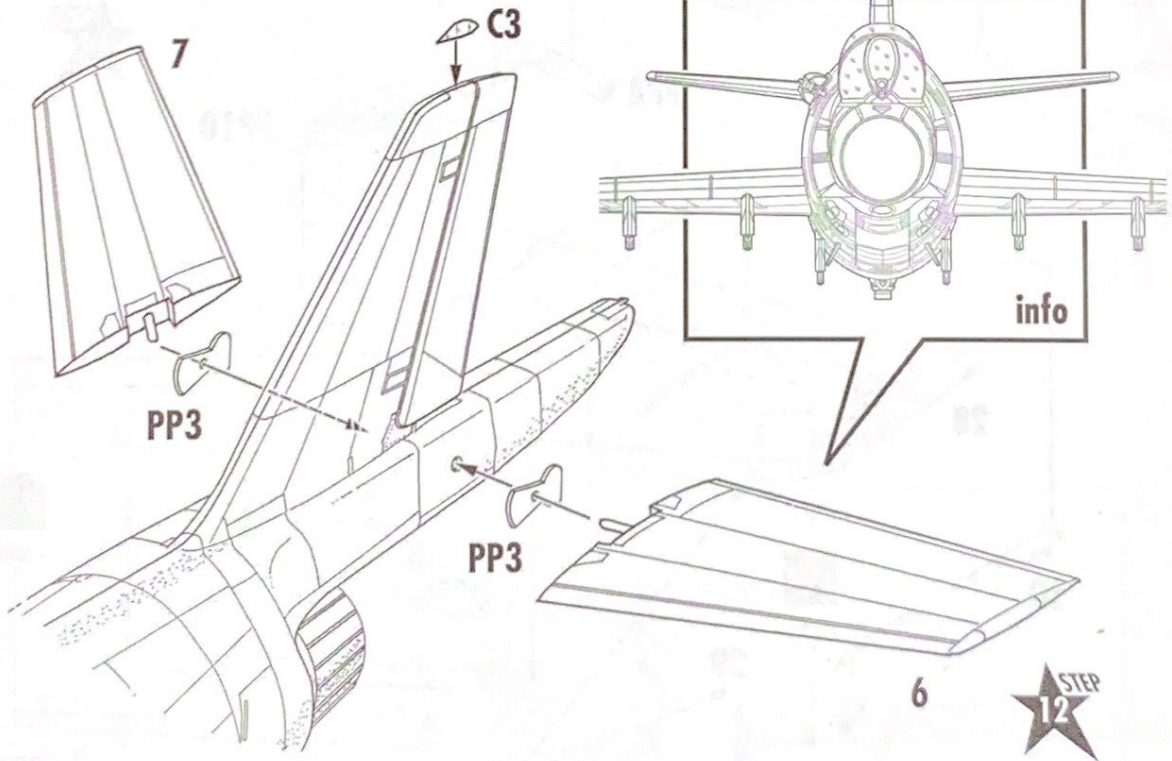
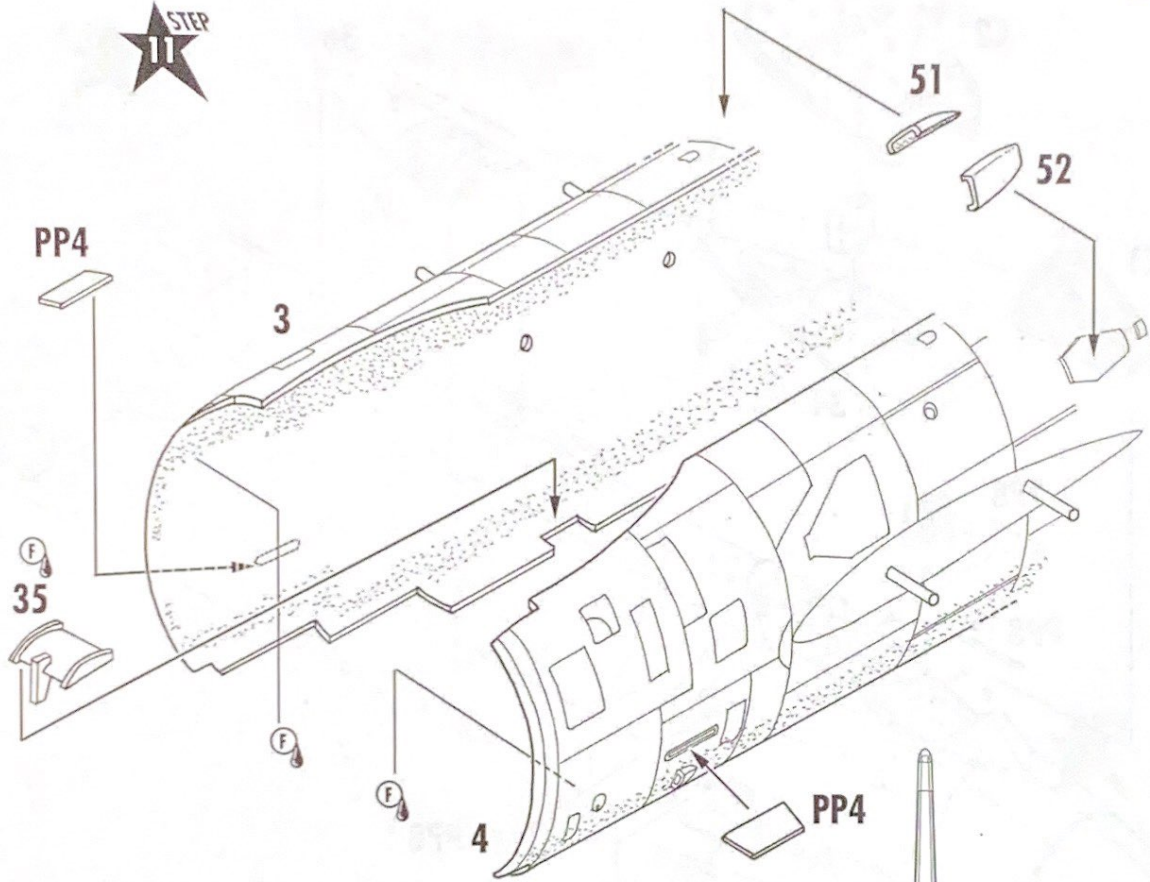

STEP 12

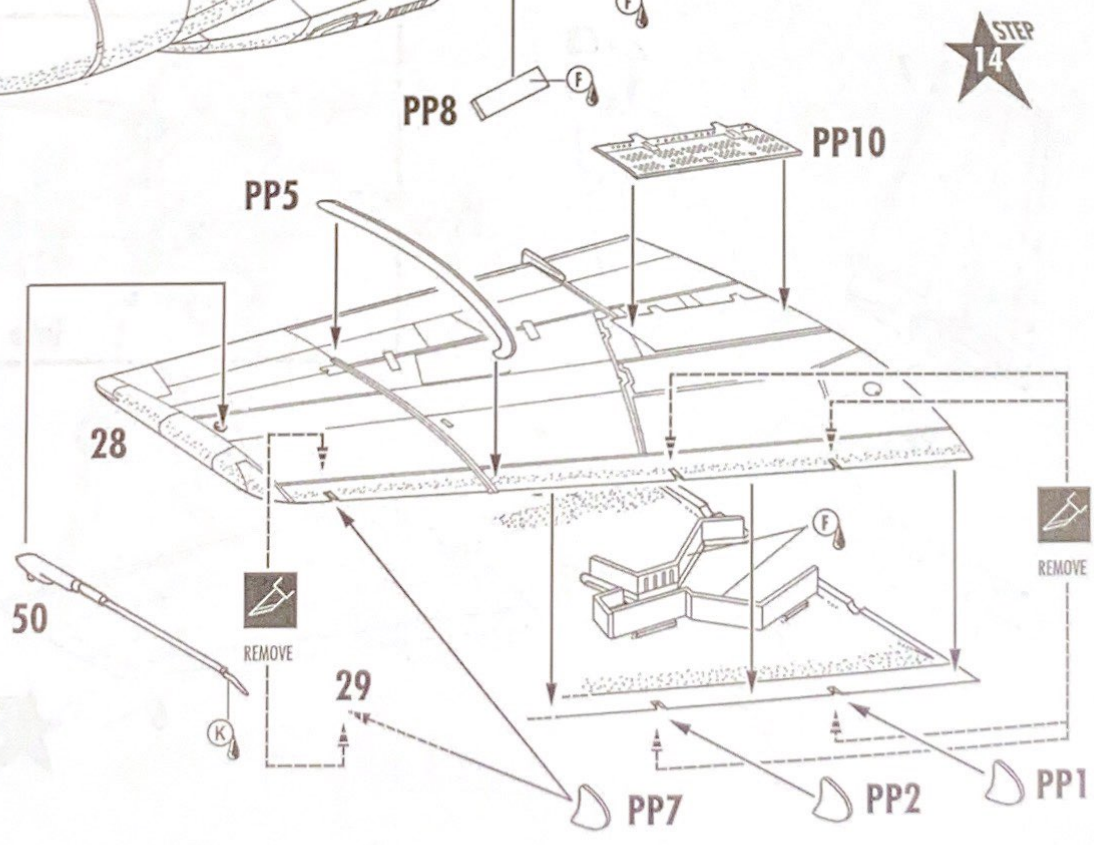
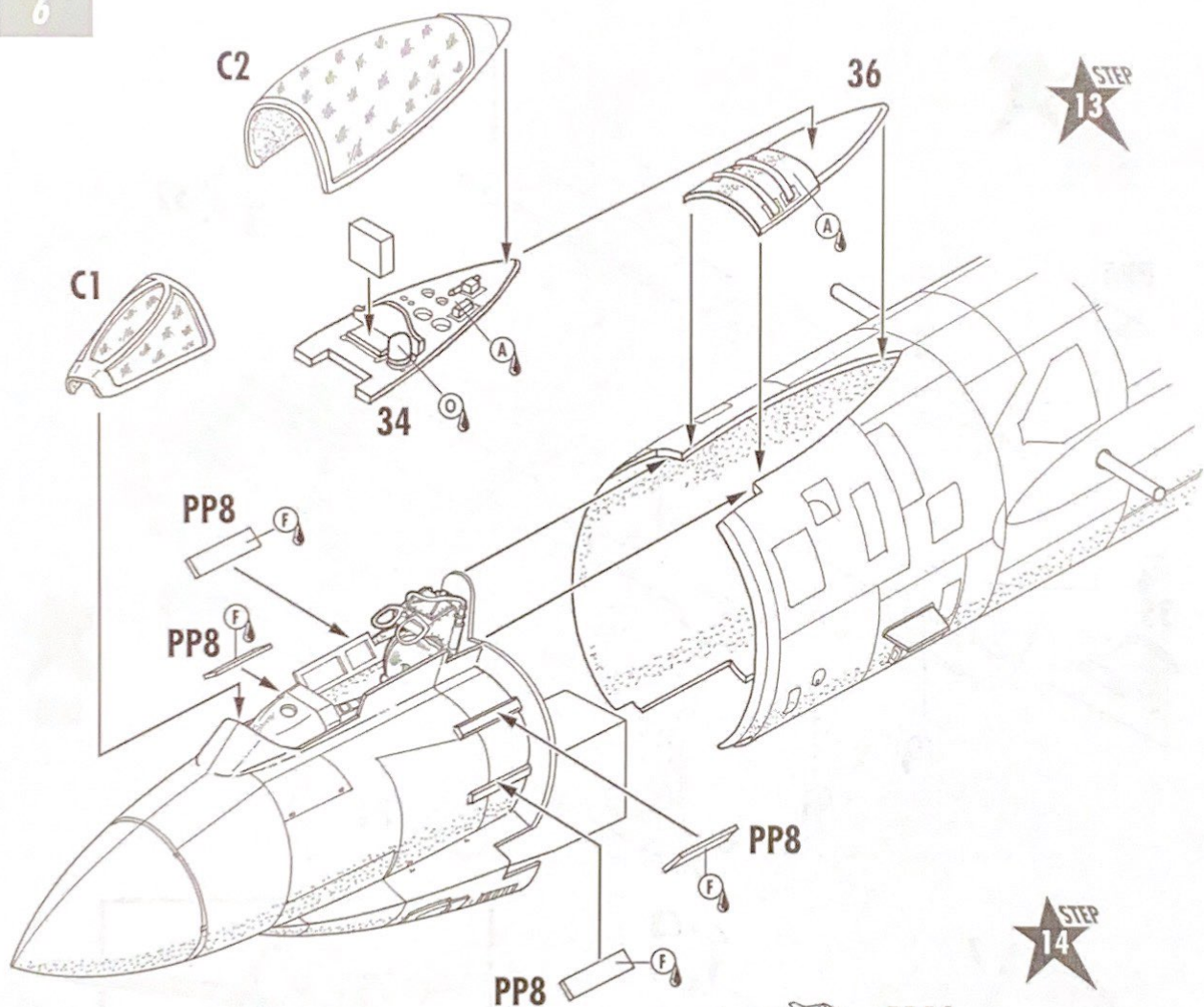

STEP 15

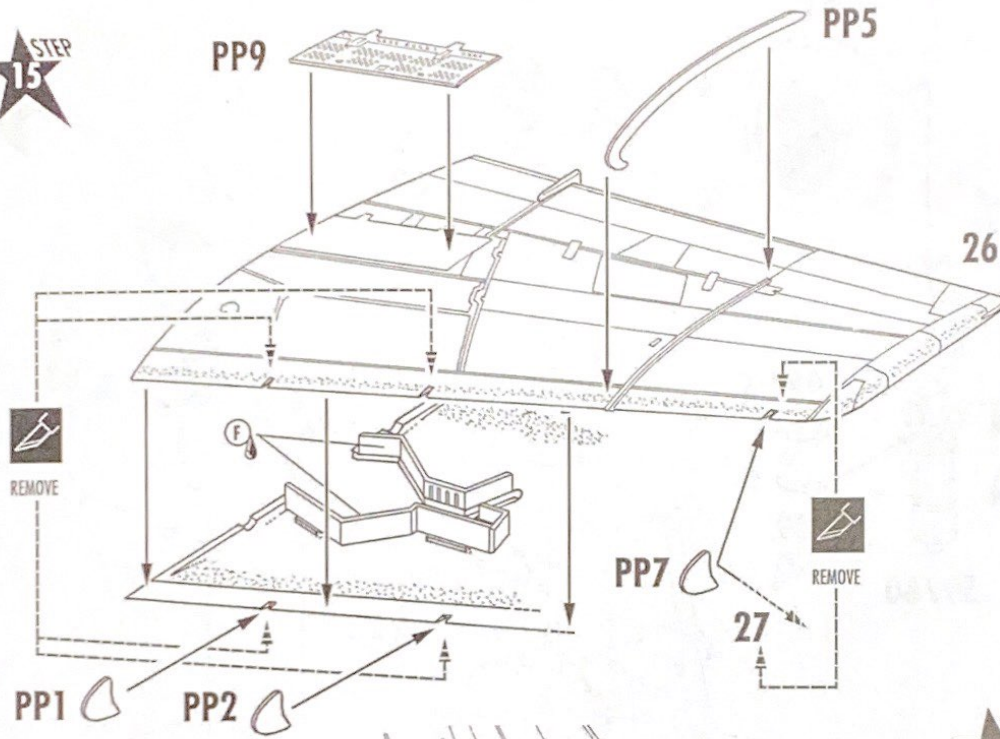

STEP 16

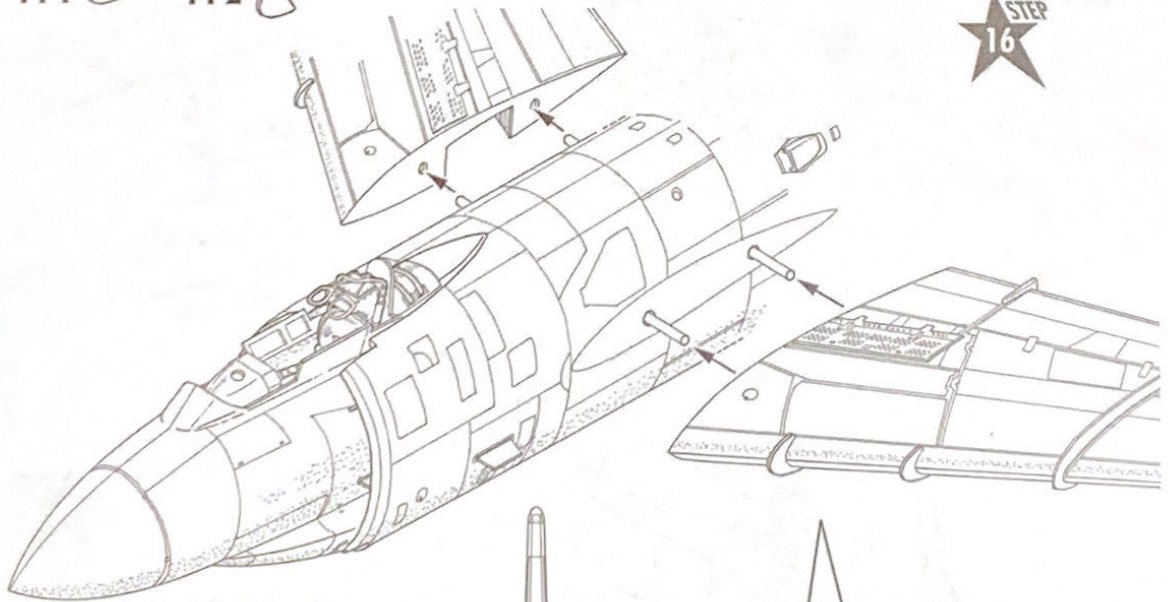

info

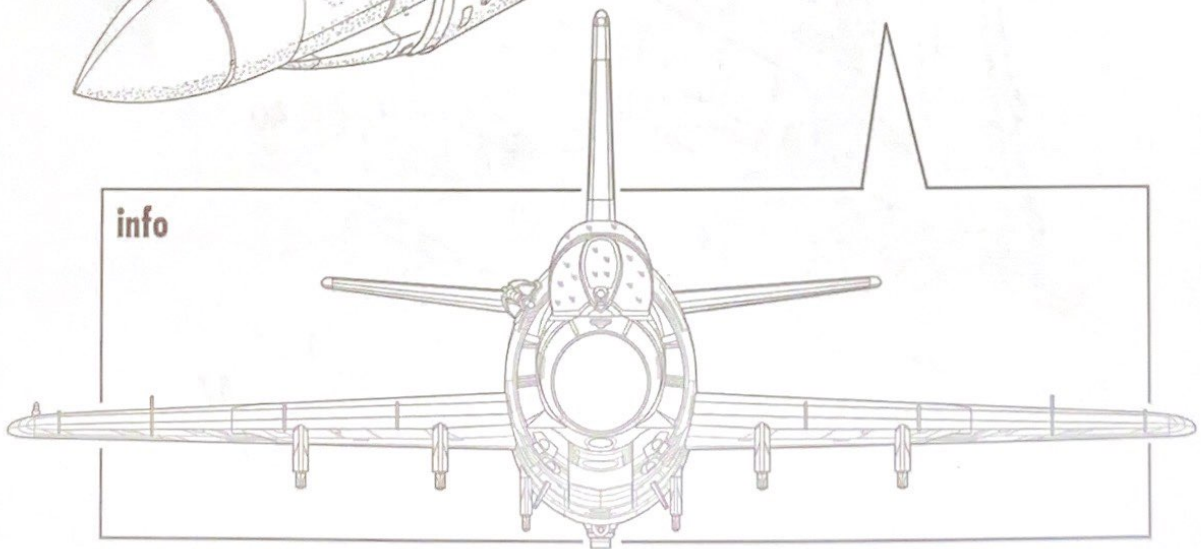

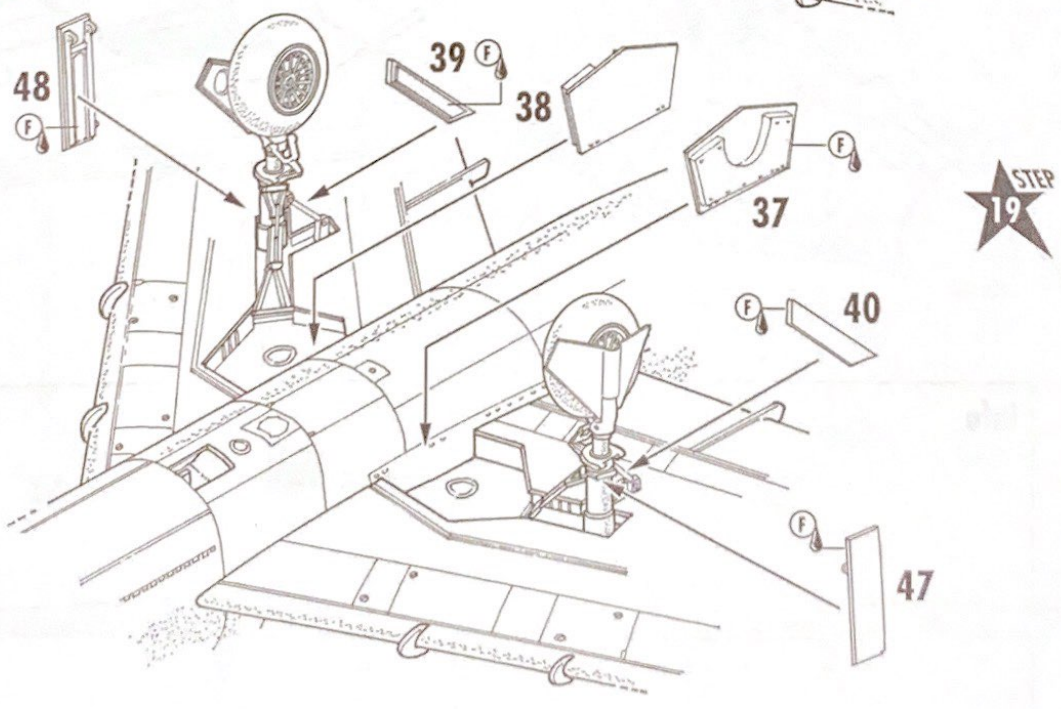
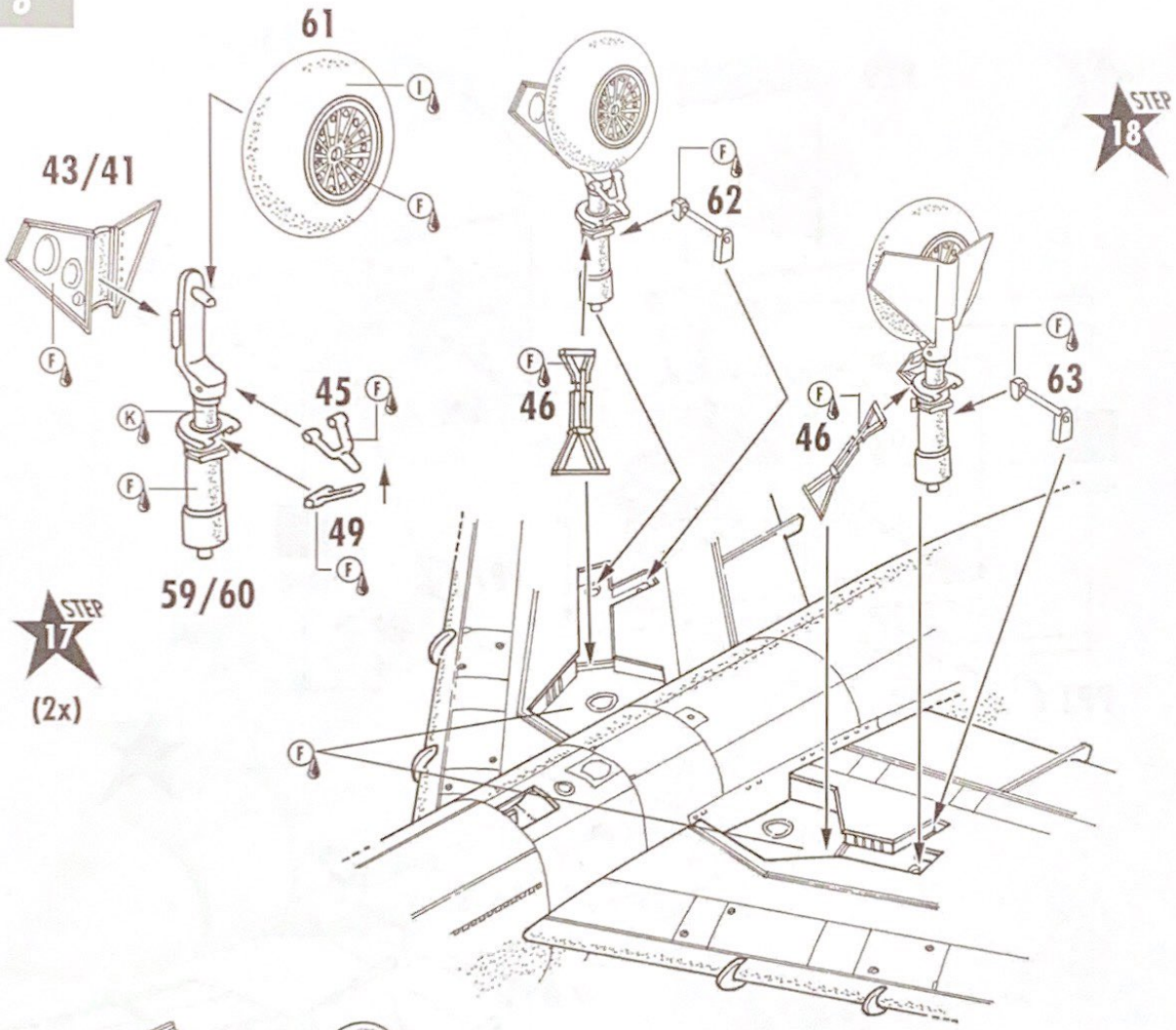

STEP 20

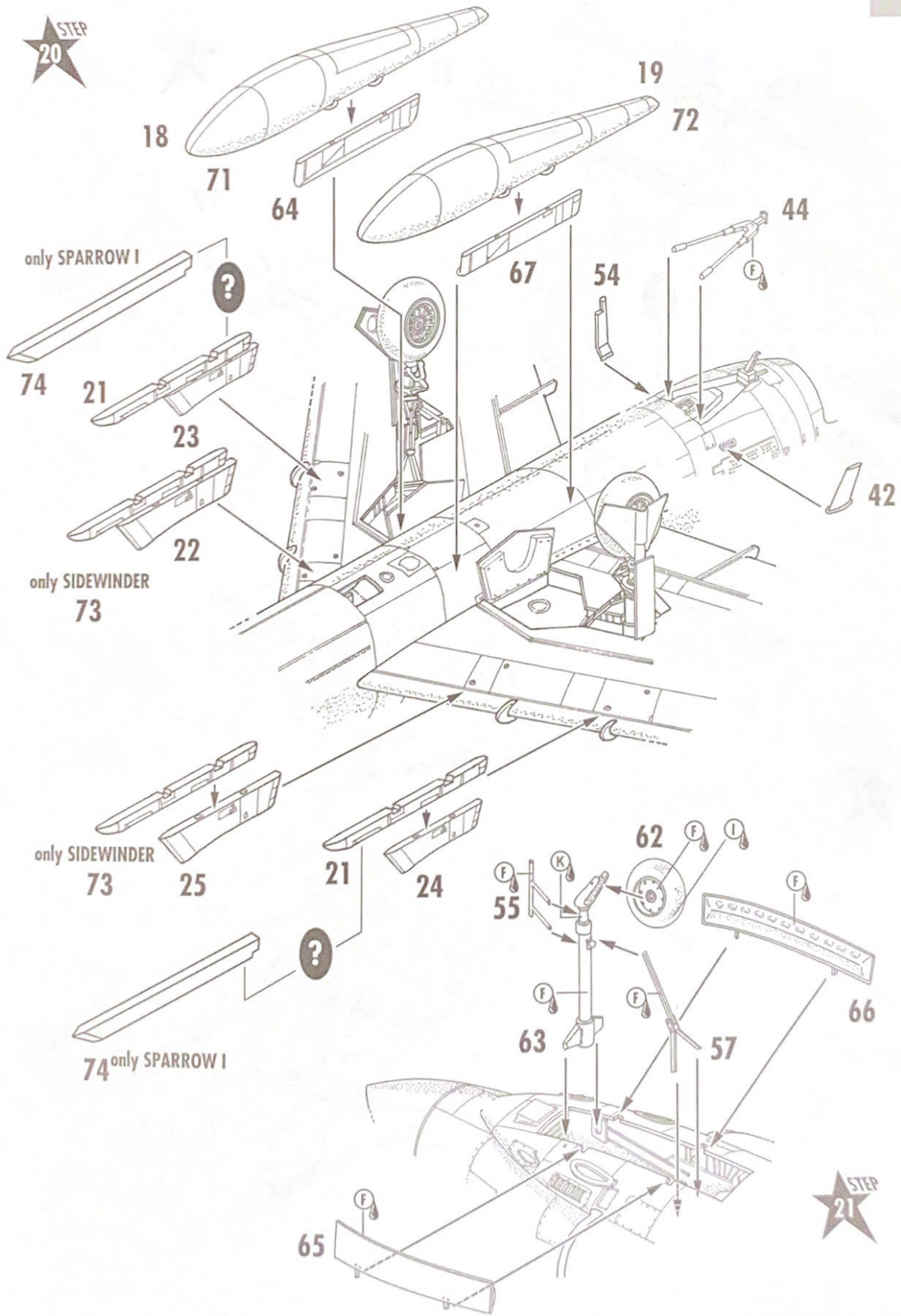

only SPARROW I

only SIDEWINDER

only SIDEWINDER

74 only SPARROW I

STEP 21

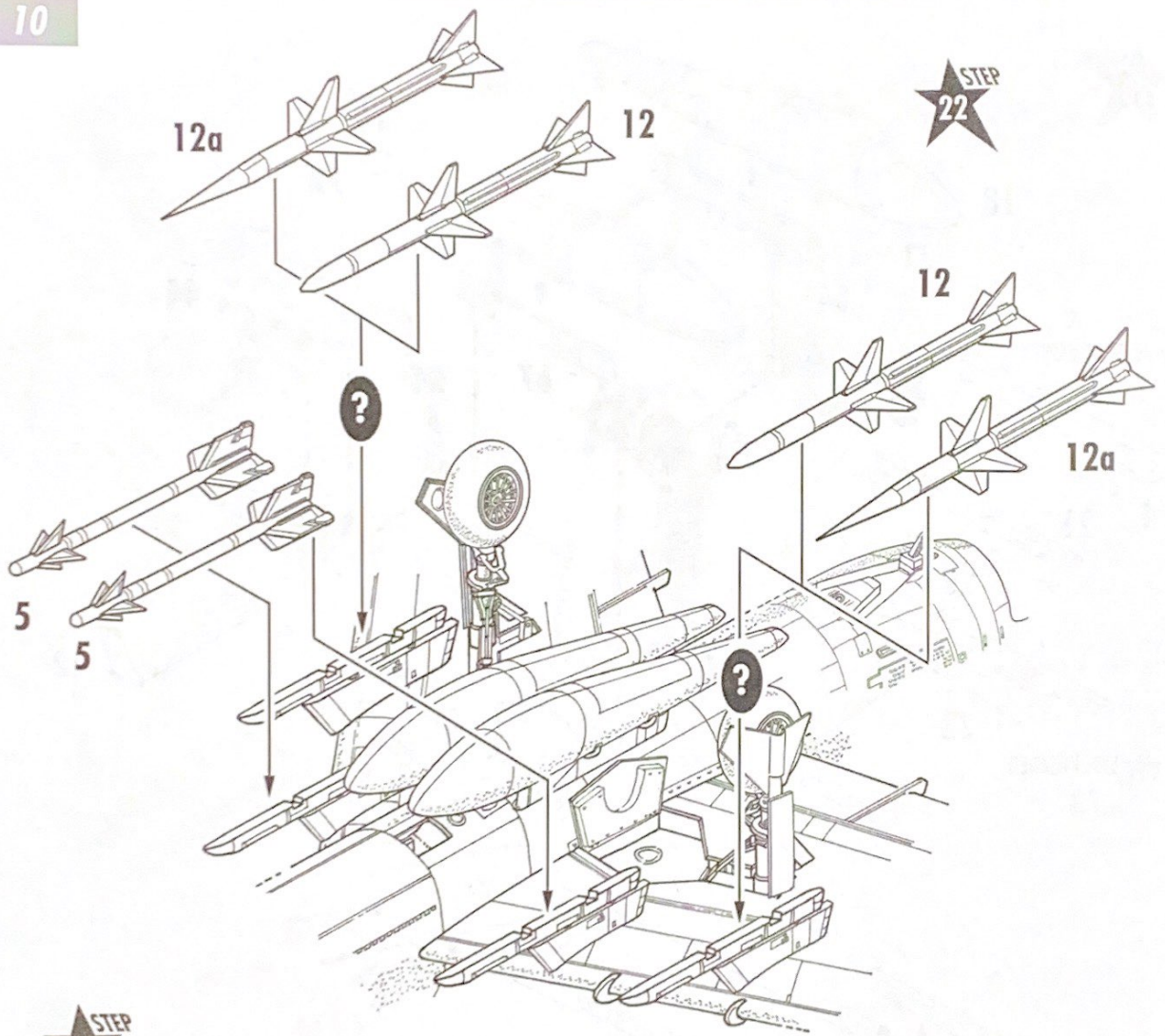

STEP 23

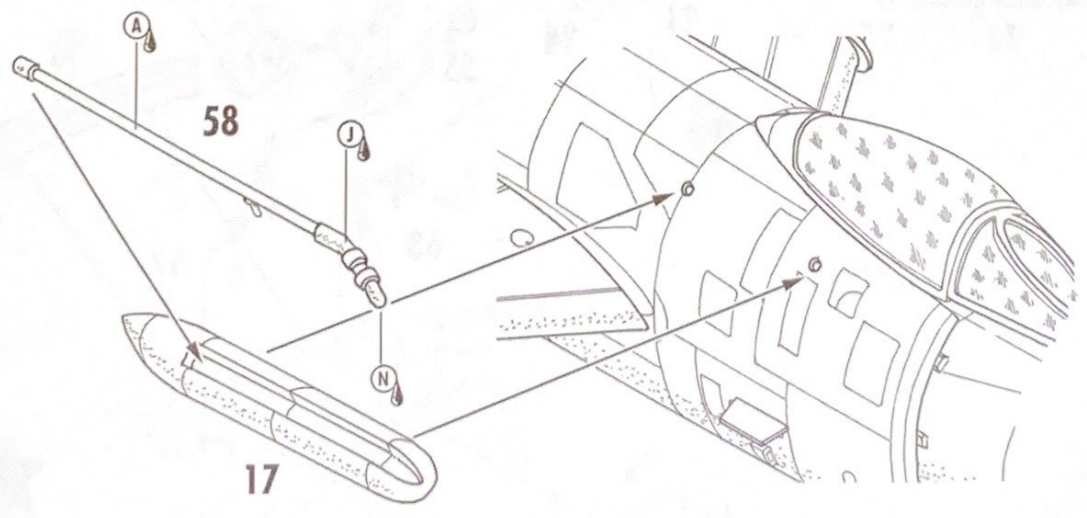

F3H-2 (F-3B) DEMON

F3H-2, VF-31 Tomcats, AC-105, Bu No. 143489, USS Saratoga, CIA 60, 1959

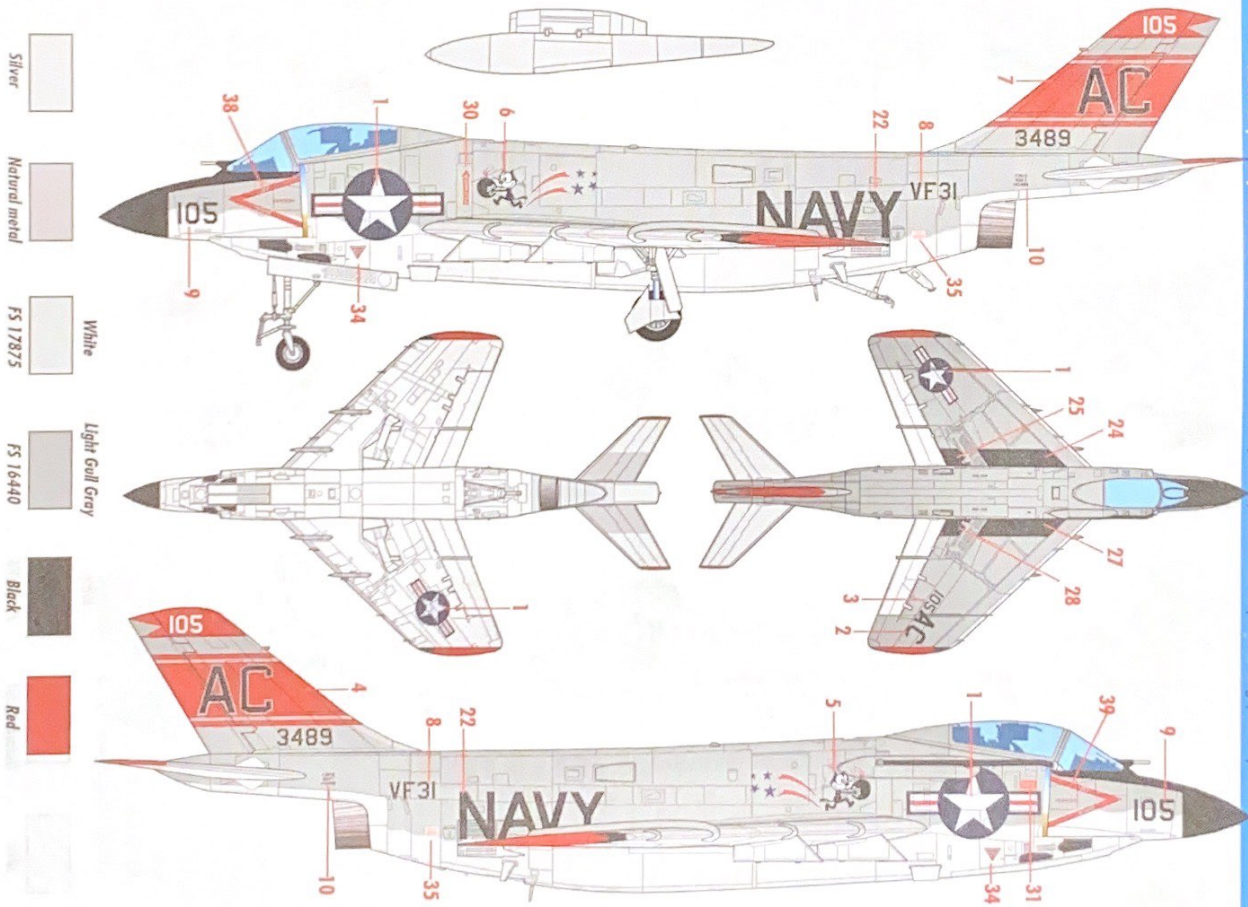

Silver

Natural metal

White

Light Gull Grey

Black

Red

FS 17875

FS 16440

F3H-2 (F-38) DEMON

F-38 VF-161 Chargers, AH-101 Bufile 149295, USS Oriskany, Miranda, 1961

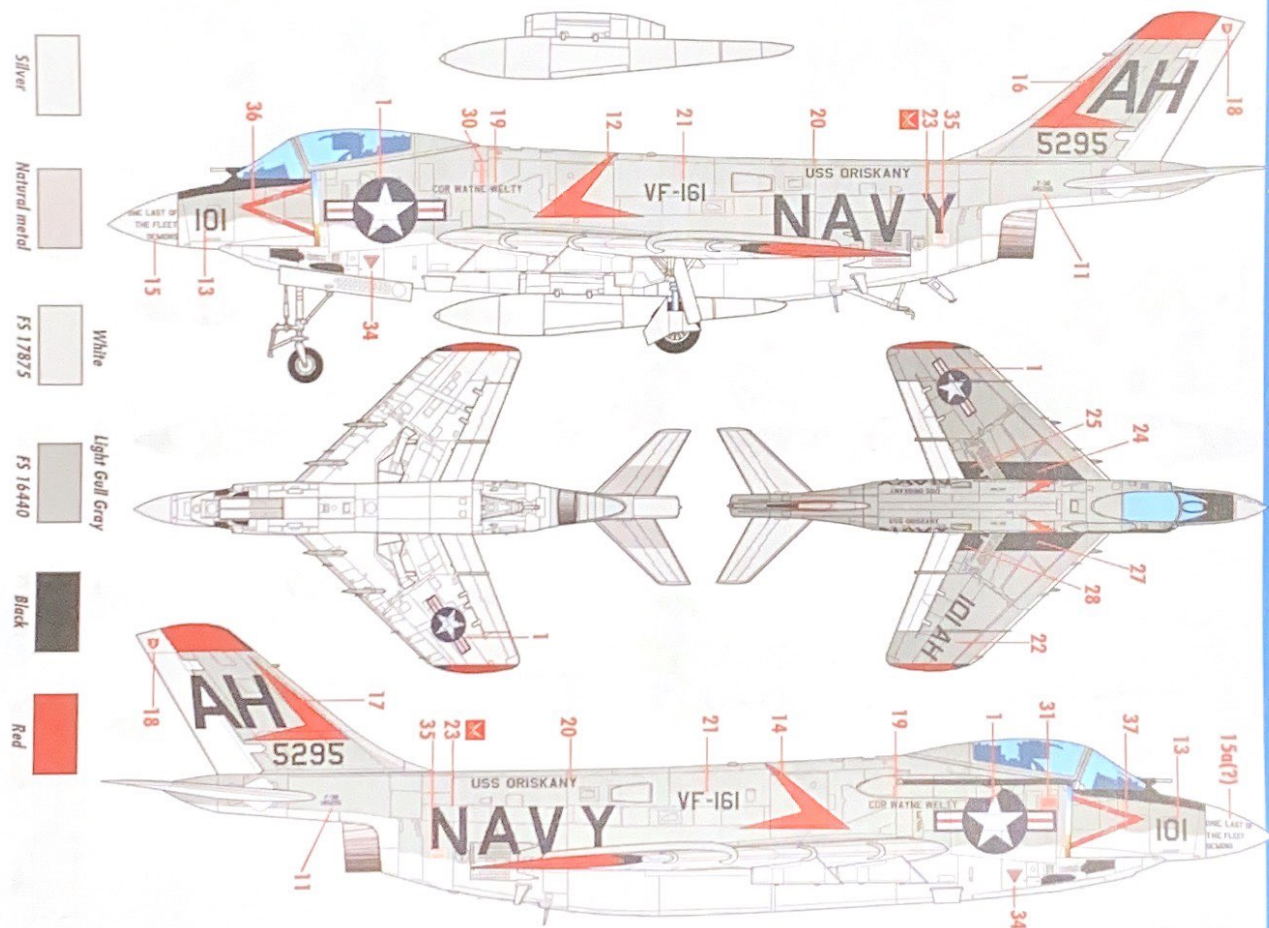

Silver

Natural metal

FS 17875

White

FS 16440

Light Gull Gray

Black

Red