

1/72 SCALE

ITEM NO.:01674

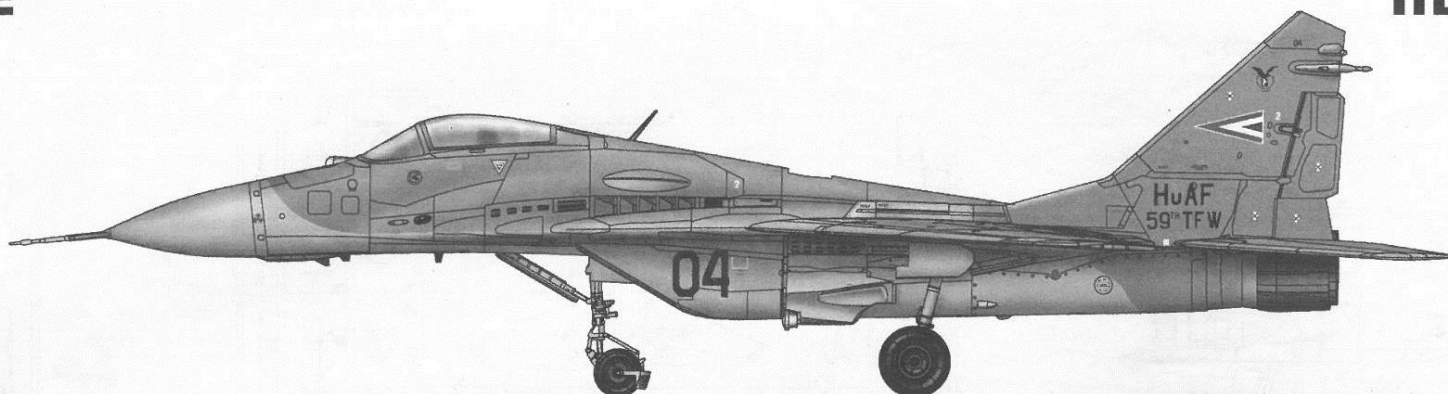

MIG-29A Fulcrum (Izdeliye 9.12)

MIG-29A “支点” 战斗机 (9.12批次)

READ BEFORE ASSEMBLY:

- This kit is not recommended for inexperienced modelers or for children under 14 years of age
- Study and understand these instructions thoroughly before beginning assembly
- When needed, remove photo-etch parts carefully using a modeling knife or photo etch sprue cutter, being careful not to damage or lose small parts.
- Take extra care in handling photo etch parts in order to avoid injury
- Apply instant cement sparingly to photo etch parts where instructed

- Tools recommended(not included in kit):Plastic and instant cements,sprue cutters,long nose pliers,modeling knife, small files, tweezers, pin vise & scissors. Soft cloth and sandpaper will also assist in construction
- Glue and paint are not included in the kit. Use plastic cement and hobby paints only. Color guide for purchasing paint is included in the kit.
- Keep out of reach of children. They must not be allowed to ingest small parts or handle plastic bags in any way.

装配之前仔细阅读

- 小心用模型锉刀锉平所有零件表面的注射浇口。
- 小心用刀片切下蚀刻片零件，不要遗失小零件。
- 用强力快干胶水粘合蚀刻片零件和金属轴。过量的快干胶水使用可能导致可动零件会粘住，小心涂胶。
- 取蚀刻片时应特别注意安全，防止利边划伤手指。
- 某些零件表面需贴水上贴纸，请选择在装配的同时进行。
- 推荐模型工具(自备)：胶水，水口剪刀，长咀钳，刀片，锉刀，镊子钳，钻，剪刀，瞬间快干胶。
- 软布同砂纸同时也应该是必备工具。
- 请使用塑料胶水和油漆，模型内不含。
- 谨防小孩吸吮塑料零件，或者将塑料袋套在头上，制作时应将套材远离小孩接触。
- 本产品不适合14岁以下没有经验的模型爱好者。

水贴纸的使用:

1. 从水贴上剪下印花;
2. 将印花放入温水中浸10秒, 然后放在干净布上;
3. 拿着印花纸板将印花移到模型上;
4. 手指蘸水将印花移到适当的位置;
5. 用软布轻压印花直至水干, 汽泡消失。

DECAL APPLICATION:

1. Cut decals from sheet as needed
2. Dip the decal in warm water for about 10 seconds and then place on soft clean cloth.
3. Hold the decal backing sheet edge and gently slide the decal onto the model in its proper position.

4. While still wet,decal can be adjusted for better fit on model by dampening it gently with your finger.
5. When placed in the proper position,gently press decal down with a soft cloth until excess water and air bubbles are gone.
6. Allow decal to dry completely before handling model



01674

1

部品图 Parts

《上机身》
Top fuselage

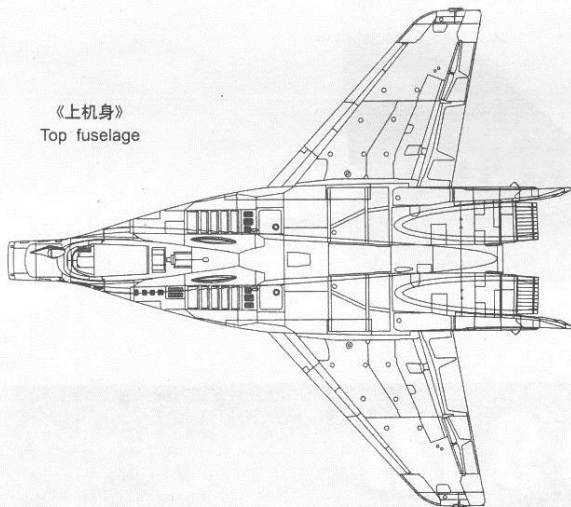

《下机身》
Lower fuselage

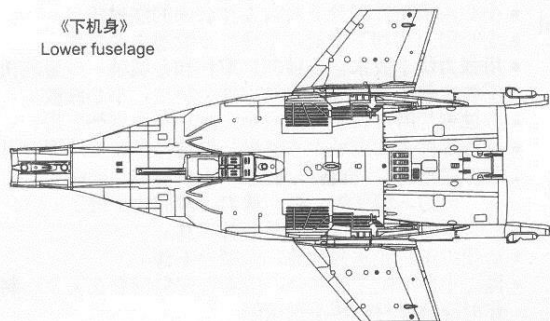

DX1

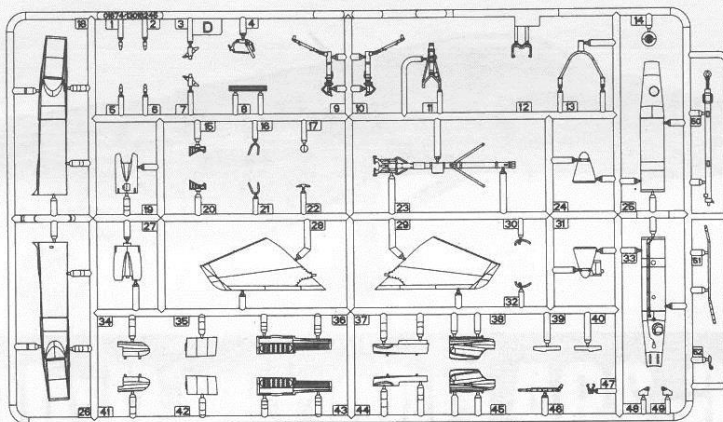

HX1

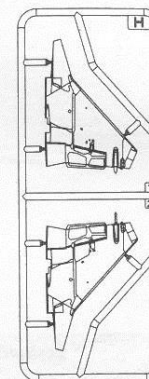

JX2

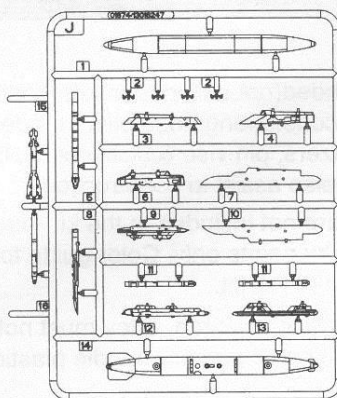

KX2

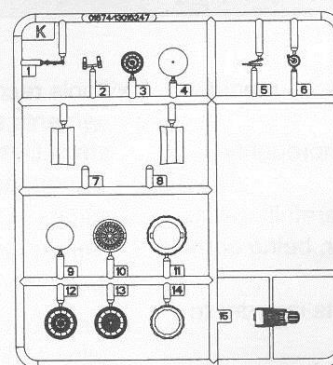

FX1

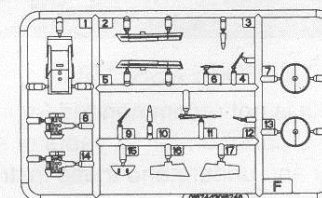

Q1X1

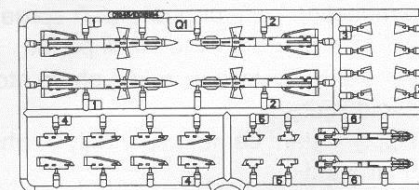

《水贴》A
Decal A

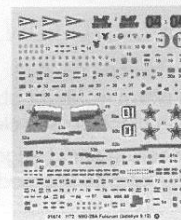

《水贴》B
Decal B

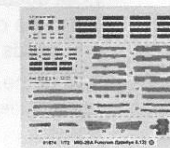

NX1

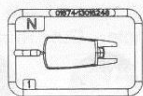

PX1

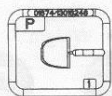

MX1

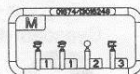

不用的部件: F3 F4 F13 F14 J2 J3 J6 J7 J10
Unused parts

1

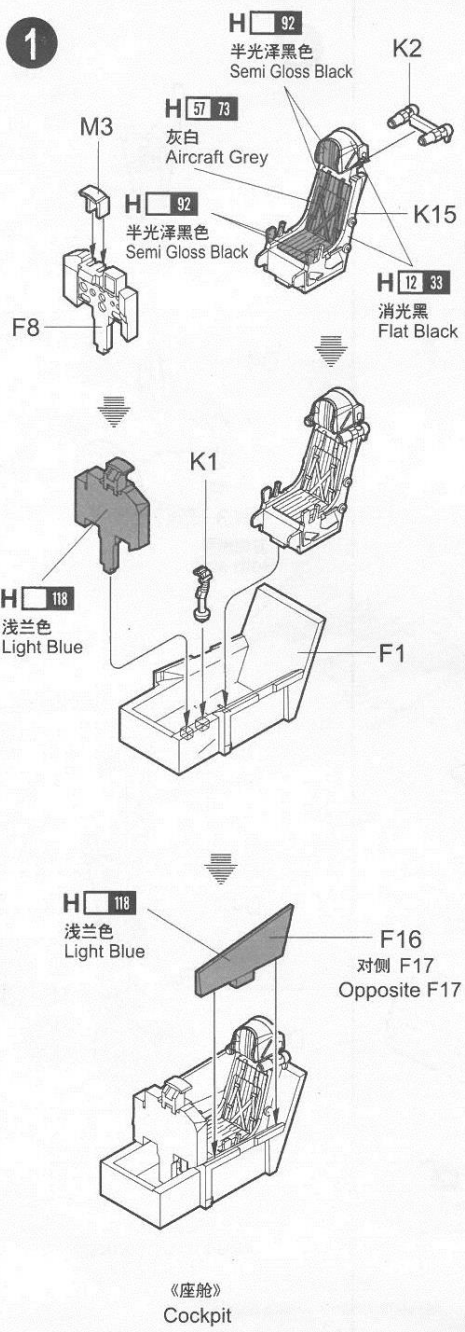

2

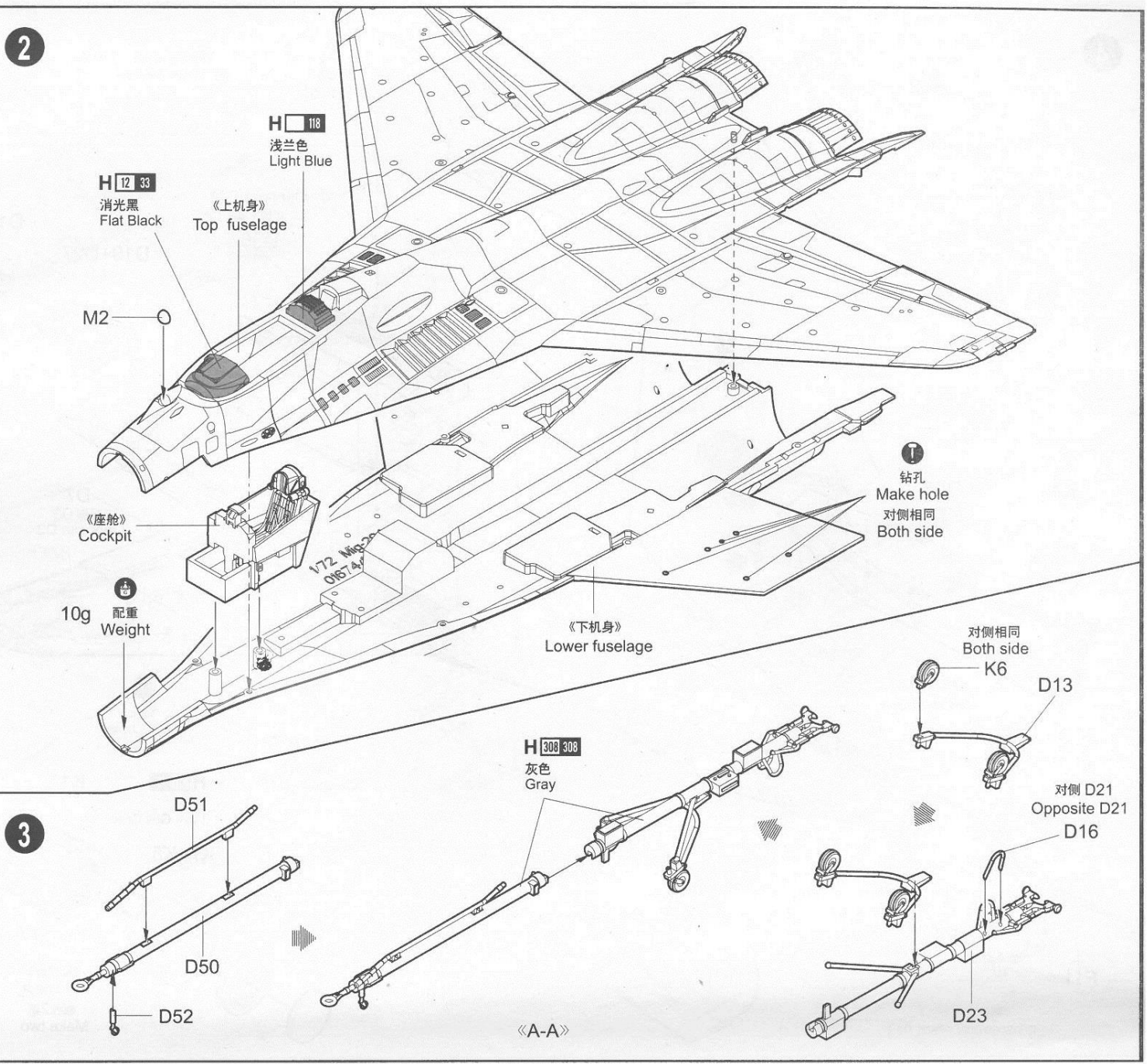

3

4

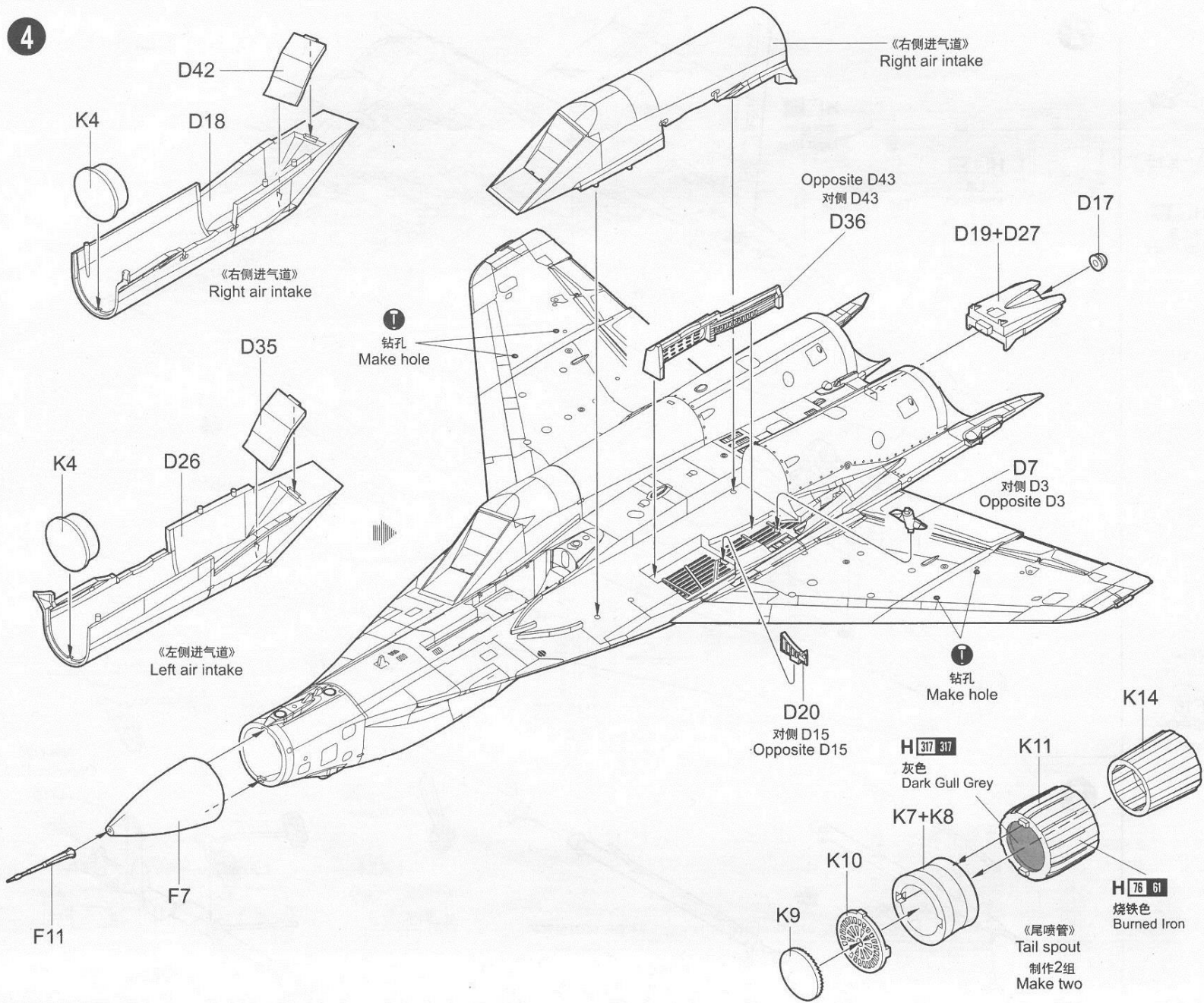

5

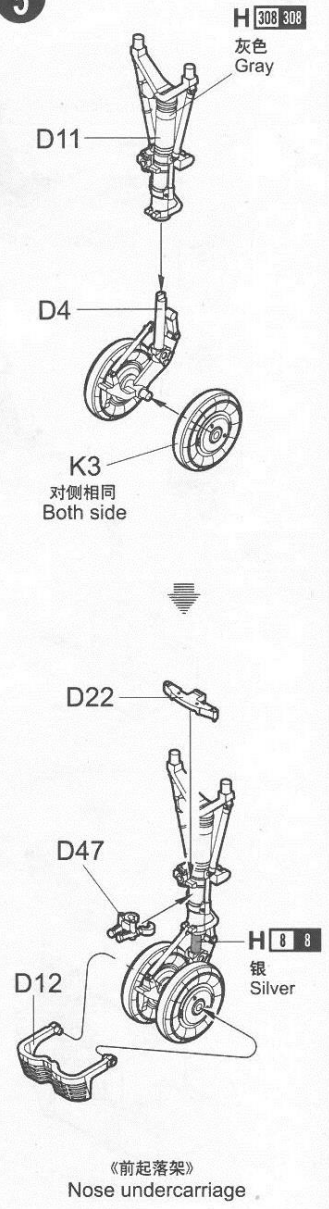

6

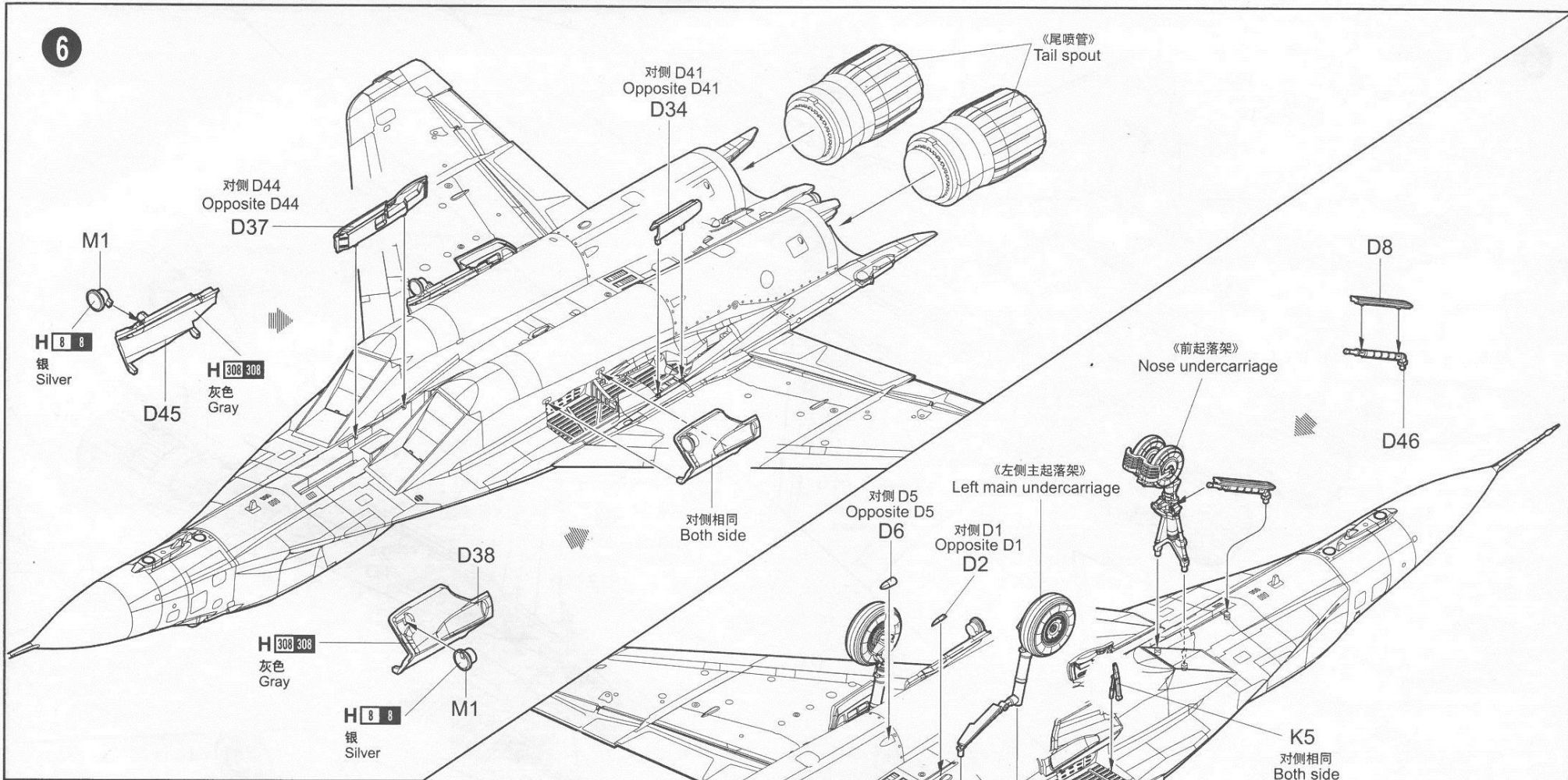

7

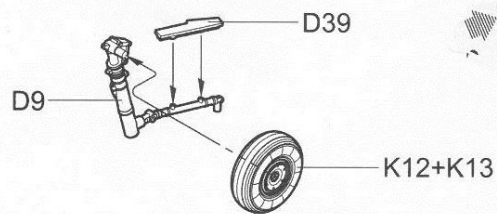

《右侧主起落架》
Right main undercarriage

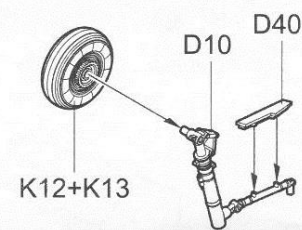

《左侧主起落架》
Left main undercarriage

8

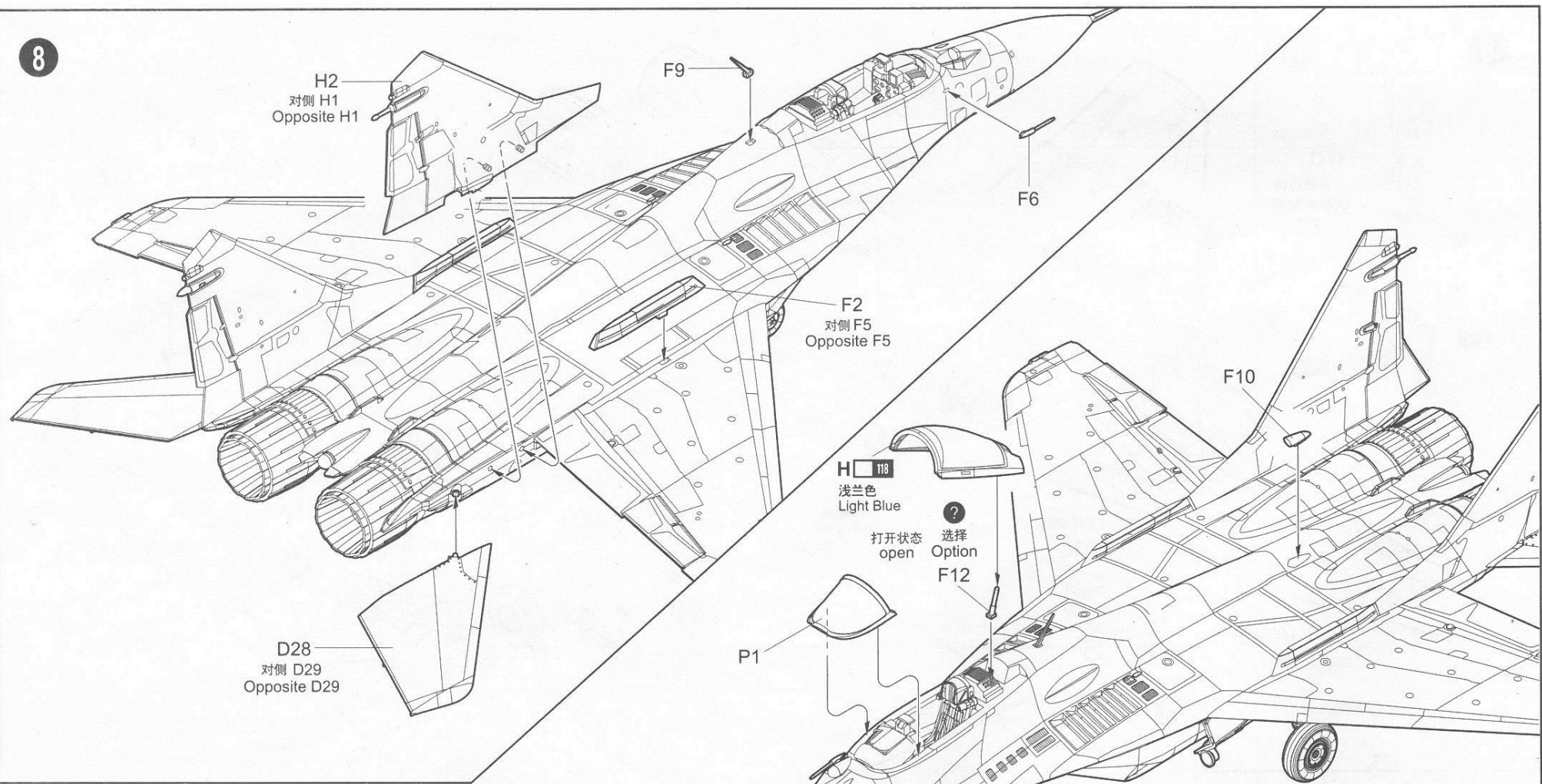

9

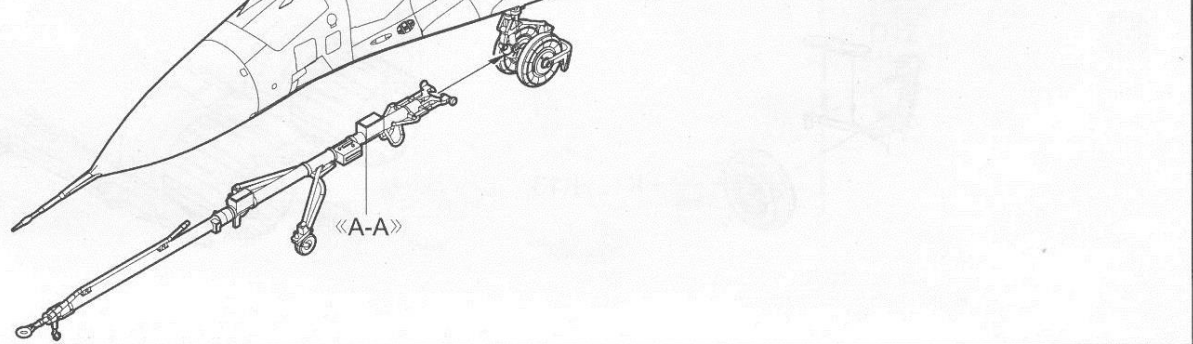
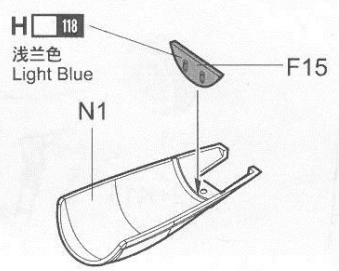

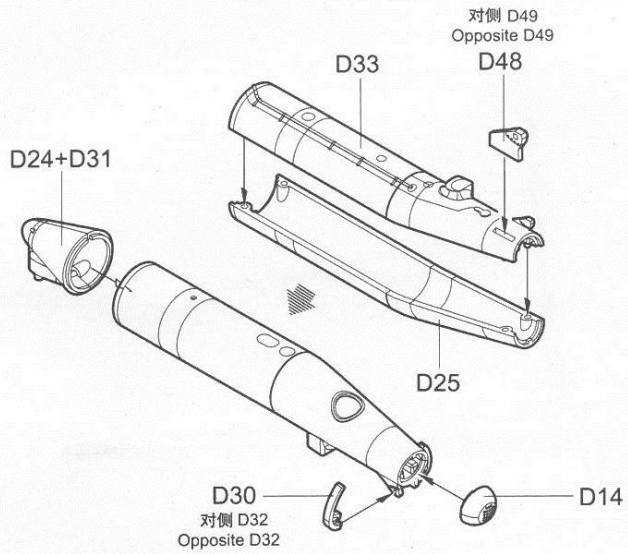

PTB-1500

对侧相同
Both sides

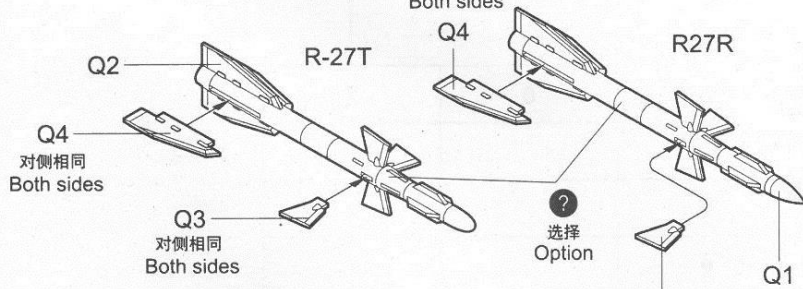

R-27T/R27R
制作2组
Make two

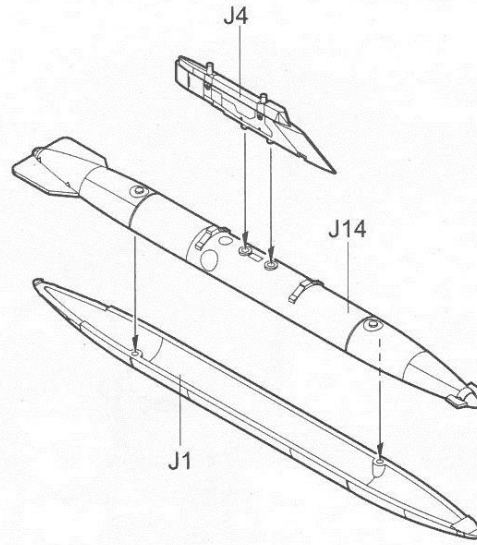

PTB-1150
制作2组
Make two

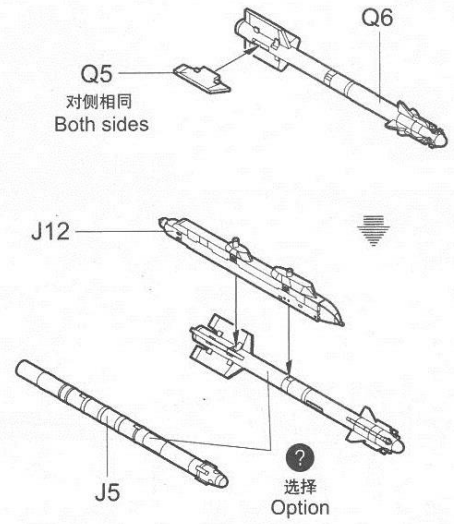

R-73E
制作2组
Make two

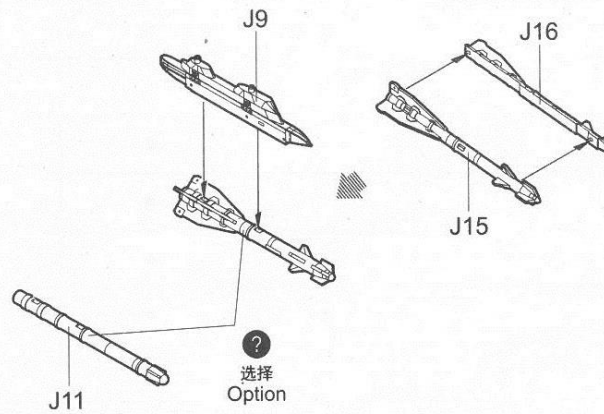

R-60
制作2组
Make two

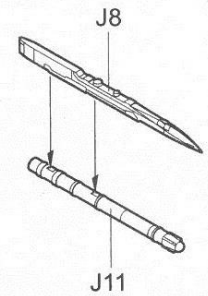

R-60
制作2组
Make two

11

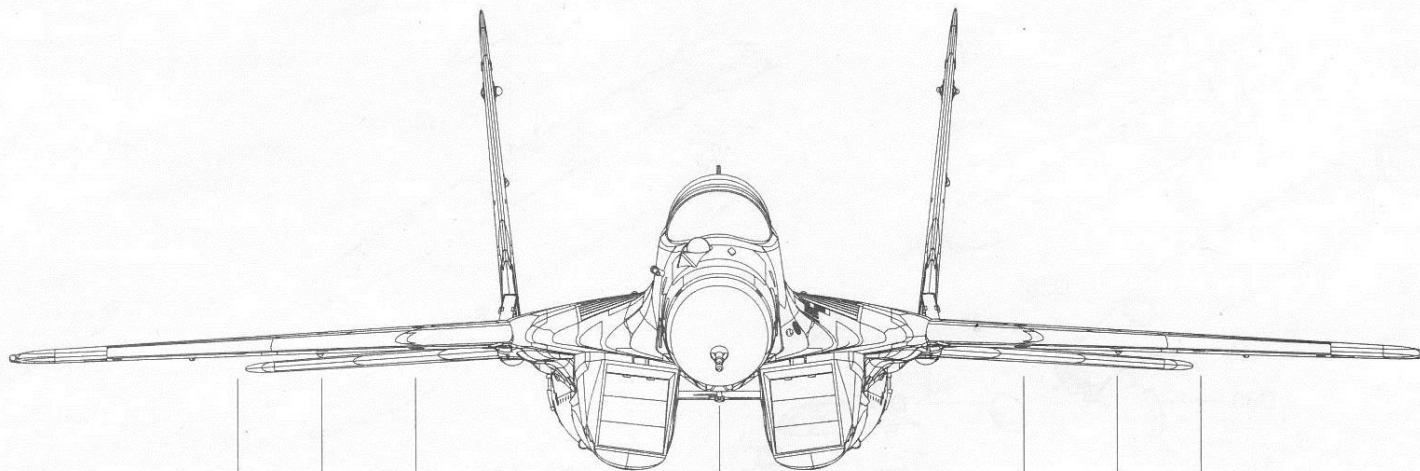

Sta.No.	1	2	3	4	5	6	7
Missile/Tank							
PTB-1500				•			
PTB-1150			•		•		
R-27T			•		•		
R-27R			•		•		
R-60	•	•	•		•	•	•
R-73E	•	•	•		•	•	•

涂装同标贴指示

Painting & Marking guide

B Russian Air Force, 21st OSAD/120th GvIAP, Domna Air Base, Mig-29A (Izdelye 9.12), '01 White'(c/n 2960515803)

PAINT REFERENCE COLOUR

Color	Mr.Hobby	Vallejo	Model Master	Tamiya	Humbrol
浅绿色 Light Green	H 819 319	—	1713	—	117
灰色 Grey	H 808 308	893	1710	XF58	116
胎黑色 Tire Black	H 171 137	—	—	—	—
棕黑色 Burnt Iron	H 76 61	863	1795	X10	53
银白色 Silver	H 8 8	997	1546	X11	11
红色 Red	H 3 3	908	1503	X7	19

PAINT REFERENCE COLOUR

Color	Mr.Hobby	Vallejo	Model Master	Tamiya	Humbrol
扁平黑色 Flat Black	H 12 33	950	1749	XF1	33
灰色 Grey	H 305 305	868	1723	XF58	125
透明红 Clear Red	H 90 47	934	—	X27	—
透明绿 Clear Green	H 84 84	936	—	X25	—
深绿色 Dark Green	H 320 320	895	—	XF26	30
浅绿色 Light Green	H 325 325	—	1730	XF55	129

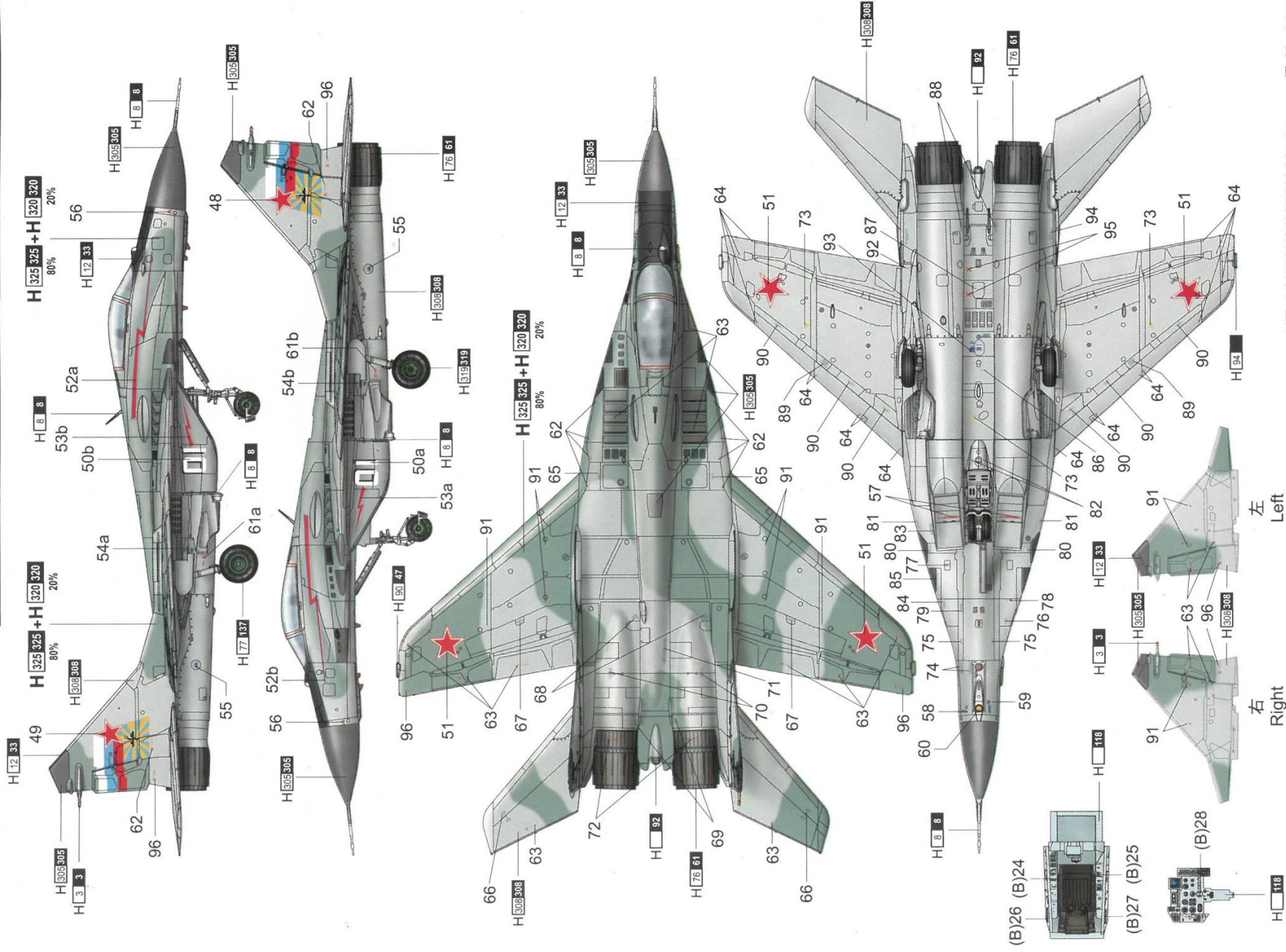

右
Right

左
Left

01674 1/72 MIG-29A Fulcrum (Izdelye 9.12) (B)

H 12 33 AQUEOUS HOBBY COLOR

H 8 8 Mr. COLOR

涂装同标贴指示

Painting & Marking guide

A Hungarian Air Force, 59th Tactical Fighter Wing, 1st 'Puma' Tactical Fighter Squadron, Mig-29A (Izdelyiye 9.12A), '04 Black' (c/n 2960535127, f/n 4508).

PAINT REFERENCE COLOUR

Color	Mr.Hobby	Vallejo	Tamiya	Model Master	Humbrol
深蓝色 Gray Blue	H 337 337	—	XF20	1721	145
灰色 Gray	H 308 308	883	XF58	1710	116
胎黑色 Tire Black	H 77 137	—	—	—	—
烧黑色 Burnt Iron	H 76 61	863	X10	1795	53
浅土色 Light tan	H 118	—	—	—	175

PAINT REFERENCE COLOUR

Color	Mr.Hobby	Vallejo	Tamiya	Model Master	Humbrol
银色 Silver	H 8 8	997	X11	1546	11
透明红 Clear Red	H 90 47	934	X27	—	—
透明绿 Clear Green	H 94	936	X25	—	—
淡灰绿色 Light Green	H 319 319	—	—	1713	117
红色 Red	H 3 3	908	X7	1503	19
白色 White	H 92	960	X18	—	—

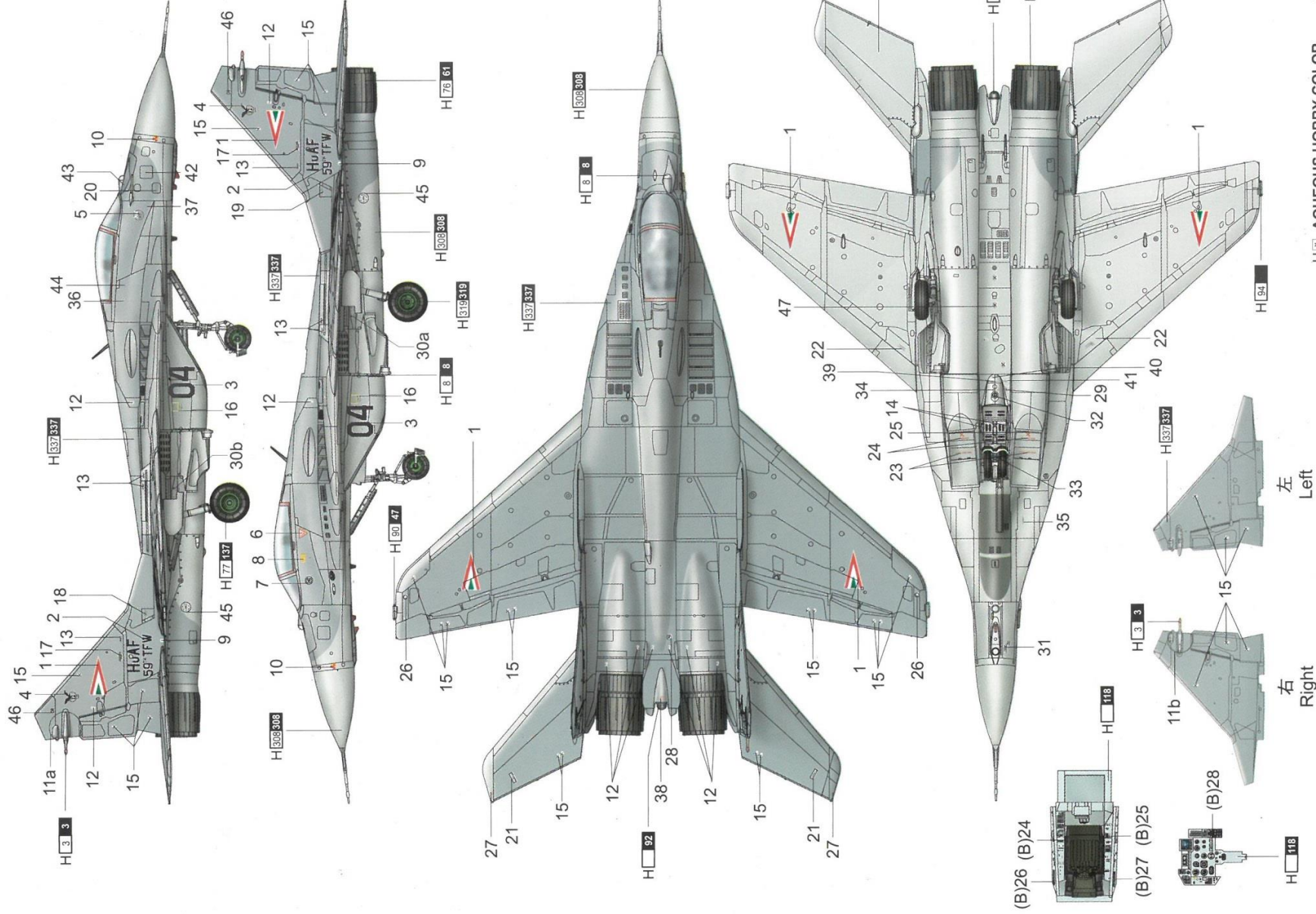

涂装同标贴指示 Painting & Marking guide

PAINT REFERENCE COLOUR

Color	Mr.Hobby	Vallejo	Model Master	Tamiya	Humbrol	Color	Mr.Hobby	Vallejo	Model Master	Tamiya	Humbrol
白色 White	H 1 1	842	1745	XF2	22	烟灰色 Smoke Blue	H 95 101	-	-	-	-
灰色 Gray	H 308 308	990	1728	XF19	127	白色 White	H 378 416	991	1745	X2	22
						灰色 Medium Gray	H 308 308	-	1741	XF22	128

R-73E x2

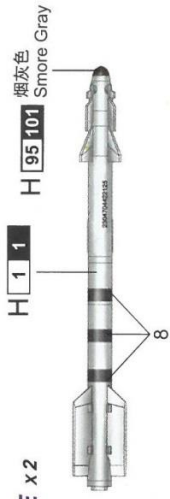

R-60 x2

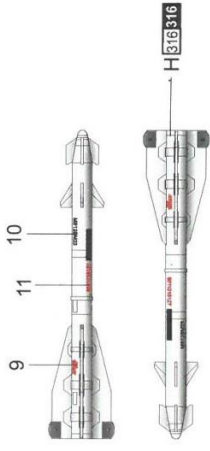

R-27R x2

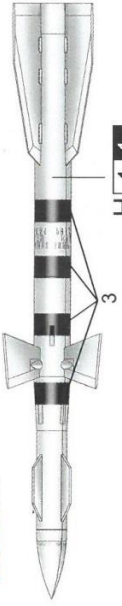

R-27T x2

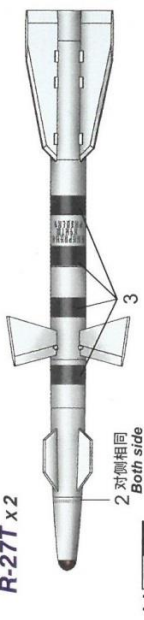

1 对侧相同
Both side



H 1 1



PTB-1500 x1

H 308 308

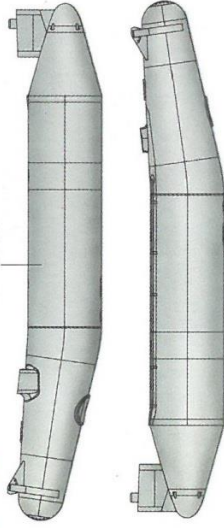

PTB-1150 x2

H 308 308

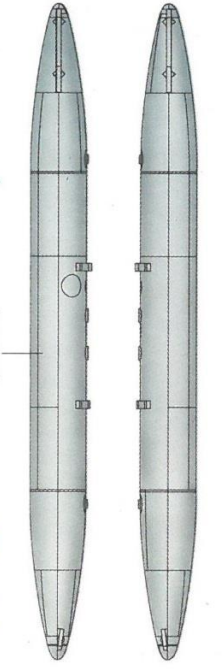

H 308 308



H 306 306



(B)14



H 308 308

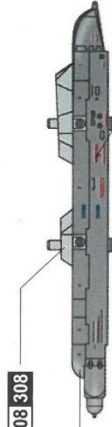

(B)16



H 306 306



(B)20



H 308 308

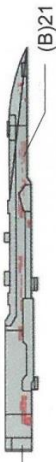

(B)22



H 308 308



