



1:72 Tiger I

A02342 SCALE MODEL CONSTRUCTION KIT | Width: 53mm, Length: 118mm | Two Decal Schemes Included | Two Build Options

EN When the mighty German Tiger I entered service during the Autumn of 1942, it was the most advanced tank in the world and one designed specifically to dominate the battlefield. Capable of destroying anything the Allies had in service, the Tiger possessed a stand-off advantage where it could 'kill without being killed', picking off enemy tanks before they could even think about returning fire. Unfortunately for the Wehrmacht, the awesome potential of the Tiger was never fully realised, as it was over engineered, extremely complex and expensive to produce, ensuring that there were never enough Tigers on the battlefield at any one time. Between 1942 and 1944, only 1,347 Tigers were manufactured and whilst it was undoubtedly one of the finest tanks ever produced, it could not hold back the ever-increasing numbers of Allied tanks. Highlighting this numerical disparity, American factories were able to produce over 49,000 Sherman Tanks during WWII.

FR Lorsque le tout-puissant Tigre I allemand entra en service à l'automne 1942, il s'agissait du char le plus avancé au monde, conçu pour dominer le champ de bataille. Capable de détruire tout ce que les Alliés utilisaient, le Tigre possédait un avantage à distance où il pouvait « tuer sans être tué », éliminant les chars ennemis avant même que ces derniers puissent penser à riposter. Malheureusement pour la Wehrmacht, l'énorme potentiel du Tigre ne fut jamais réalisé car son design était trop complexe et coûteux à fabriquer, ce qui signifiait qu'il n'y avait jamais assez de Tigres sur le champ de bataille à un moment donné. Entre 1942 et 1944, seulement 1.347 Tigres furent produits. Bien qu'il s'agisse indubitablement de l'un des meilleurs chars jamais fabriqués, ils ne purent repousser le nombre toujours croissant de chars alliés. Soulignant cette disparité numérique, les usines américaines pouvaient produire plus de 49.000 chars Sherman pendant la Deuxième Guerre mondiale.

DE Als der Tiger I im Herbst 1942 erstmalig von der Wehrmacht in Dienst gestellt wurde, verfügte sie damit über den technisch fortgeschrittensten Panzer der Welt. Er war als unverwundbarer Rammbock entworfen und im Deutschen Reich hochstilisiert worden. Mit seiner Feuerkraft war er allen alliierten Panzern überlegen. Er konnte feindliche Panzer oft zerstören, bevor diese überhaupt in schussbereiter Entfernung angeordnet waren. Das echte Potenzial des Tigers konnte aber von der Wehrmacht nie wirklich ausgenutzt werden. Infolge seiner überhöhten, gleichzeitig aber störanfälligen Technik war seine Herstellung äußerst aufwändig; das war auch der Grund, warum niemals genug Tiger auf dem Schlachtfeld zur Verfügung waren. Von 1942 bis 1944 wurden bloß 1347 Tiger hergestellt. Und obwohl sie zu den besten je gebauten Panzern zählen, konnten sie die ständig zunehmende Zahl der Panzer der Alliierten nicht zurückhalten. Die rein zahlenmäßige Überlegenheit des Herstellungsvolumens der amerikanischen Fabriken unterstreicht diese Tatsache: 49.000 Sherman Panzer wurden dort im Zweiten Weltkrieg produziert.

ES Cuando entró en servicio en el otoño de 1942, el imponente Tiger I alemán era el tanque más avanzado del mundo, diseñado específicamente para el dominio en el campo de batalla. Con capacidad para destruir cualquier unidad de los aliados, el Tiger contaba con la ventaja de poder mantenerse a una distancia desde la que podía "matar sin morir", eligiendo enemigos antes siquiera de que pudieran pensar en devolver el fuego. Por desgracia para la Wehrmacht, el Tiger jamás llegó a hacer plenamente realidad su increíble potencial, ya que adolecía de un exceso de ingeniería, era extremadamente complejo y resultaba caro de producir, lo que impidió que nunca hubiera suficientes unidades Tiger en el campo de batalla en ningún momento dado. Entre 1942 y 1944, solo se fabricaron 1347 unidades del Tiger y, aunque no cabe duda de que fue uno de los mejores tanques jamás producidos, no podía hacer frente al número de tanques aliados en constante aumento. En fuerte contraste numérico, las factorías estadounidenses pudieron producir más de 49 000 tanques Sherman durante la Segunda Guerra Mundial.

SV När den tyska Tiger I, specialutformad för dominans på slagfältet, inleddes sin tjänstgöring hösten 1942 utgjorde den världens mest avancerade stridsvagn. Tiger, med kapacitet att förstöra allt som de allierade satte in i denna fas, åtnjöt en stor fördel eftersom den kunde "döda utan att dödas", dvs. slå ut fiendens stridsvagnar innan dessa kunde returnera eld. Olyckligtvis för Wehrmacht förverkligades aldrig Tiger-vagnens enorma potential, eftersom den var överkonstruerad, mycket komplex och dyr att producera, vilket resulterade i att det aldrig fanns tillräckligt med Tiger-vagnar på slagfältet vid ett och samma tillfälle. Mellan 1942 och 1944 tillverkades blott 1 347 Tiger-vagnar, och trots att Tiger onekligen var en av de mest avancerade stridsvagnar som någonsin producerats kunde den inte stå emot det ständigt ökade antalet allierade stridsvagnar. Detta faktum illustreras av att amerikanska fabriker producerade mer än 49 000 Sherman-stridsvagnar under andra världskriget.

Specification:

Maximum Speed: 25 mph (40km/h)
 Range: 121 miles (195km/h)
 Crew: 5
 Length: 25 ft 9.0 in (8.45 m)
 Armament: 1 x 8.8 cm KwK36 anti-tank gun and 2 x 7.92 mm MG34 machine guns

Spécification:

Vitesse maximale: 40km/h
 Autonomie: 195 km
 Équipage: 5
 Longueur: 8,45 m
 Armement: un canon antichar KwK36 de 88 mm et deux mitrailleuses MG34 de 7,92 mm

Spezifikation:

Höchstgeschwindigkeit: 40 km/h
 Reichweite: 195 km
 Besatzung: 5 Mann
 Länge: 8,45 m
 Bewaffnung: eine 8,8 cm KwK36 Panzerabwehrkanone und zwei 7,92 mm MG 34.

Especificación:

Velocidad máxima: 40 km/h
 Autonomía: 195 km
 Tripulación: 5
 Longitud: 8,45 m
 Armamento: 1 cañón antitanque KwK36 8,8 cm y 2 ametralladoras Mg34 de 7,92 mm

Spécification:

Maximal hastighet: 40 km/h
 Räckvidd: 195 km
 Besättning: 5
 Längd: 8,45 m
 Beskygning: En 8,8 cm pansarvärnskanon KwK 36 och två 7,92 mm MG34-kulgevårar

FOR BEST RESULTS:

Surfaces to be painted should be clean – before parts are removed from the sprue, wash in warm, soapy water, rinse and dry thoroughly. Stir paints thoroughly before use.

PLEASE NOTE:

Some parts in the kit may not be required to build the model specified.

HORNBY HOBBIES





Note: There are two build options for the track assembly for this model. Airfix recommend that less experienced modellers use the pre-assembled tracks option shown in the left hand illustration below.

If using the simpler, pre-assembled track parts, follow Steps 1 to 25, miss out Steps 26 to 60 and finish with Step 61.

If using the separate track parts, follow Steps 1 to 22, miss out Steps 23 to 25, and then follow Steps 26 to 61.

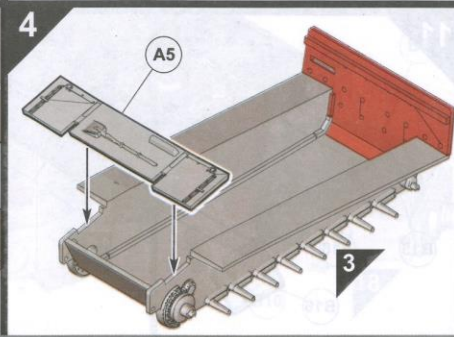
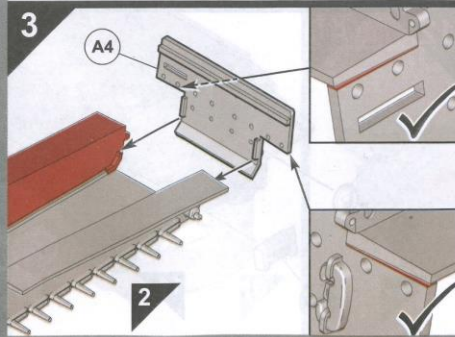
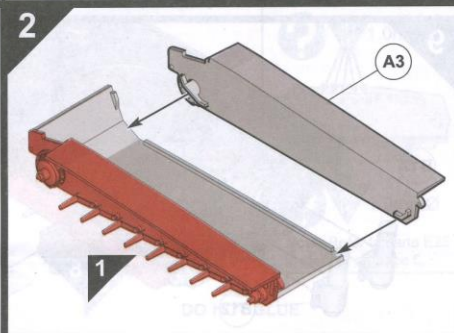
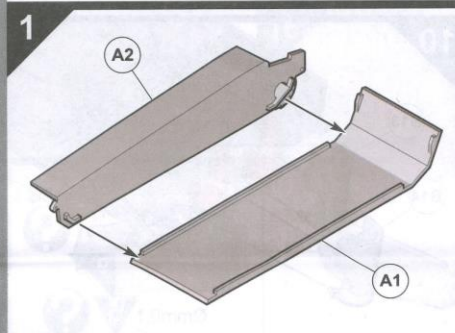
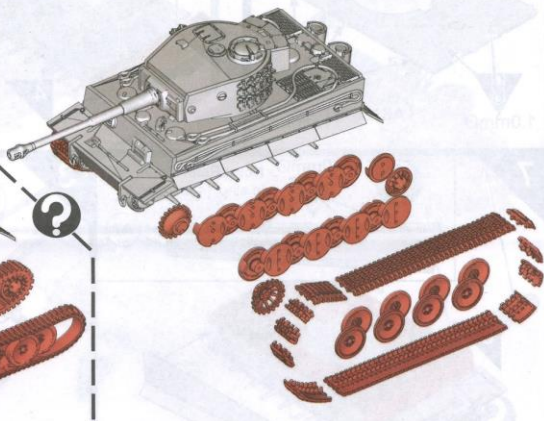
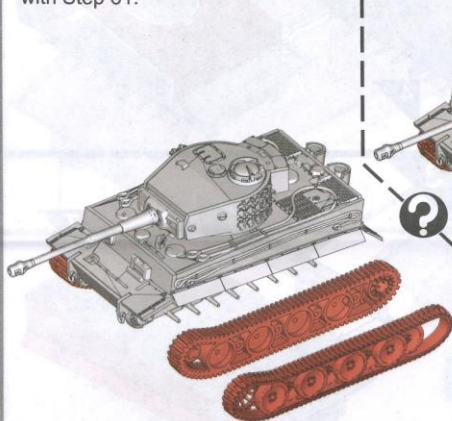

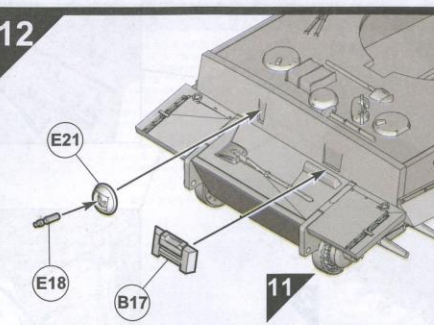
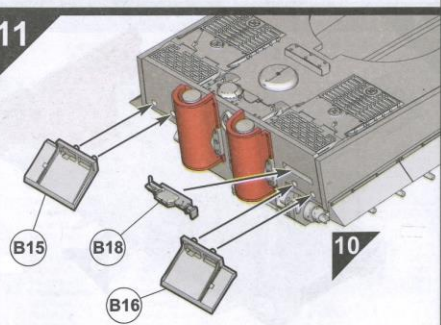
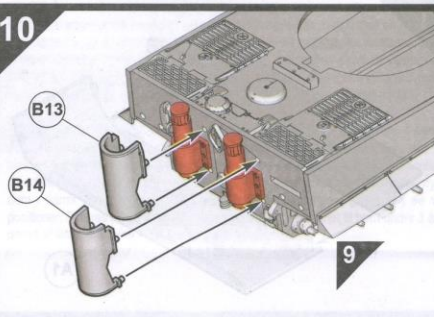
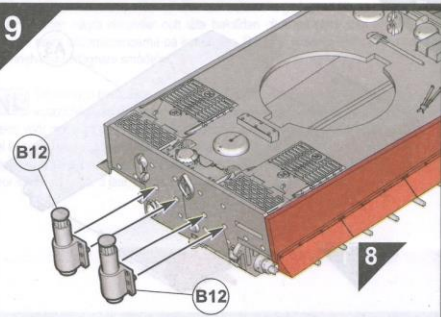
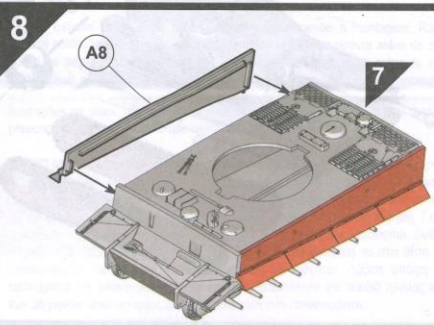
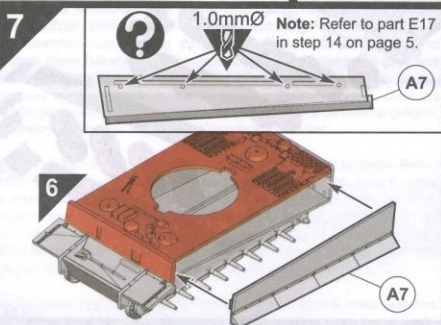
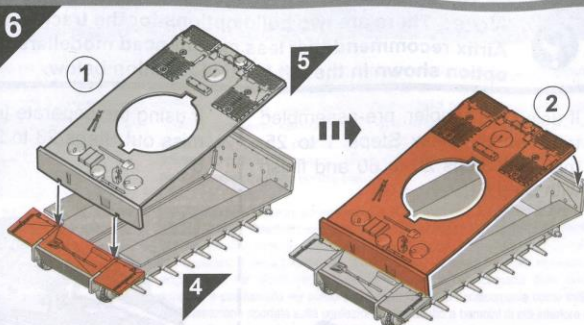
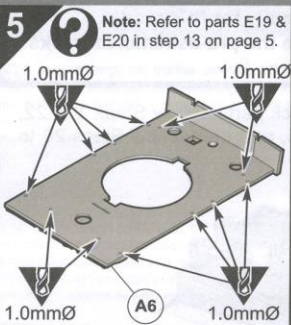

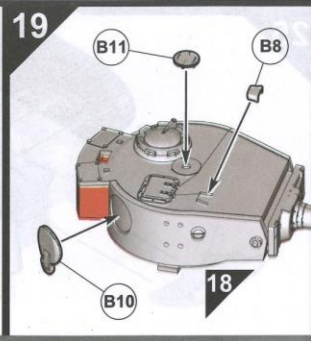
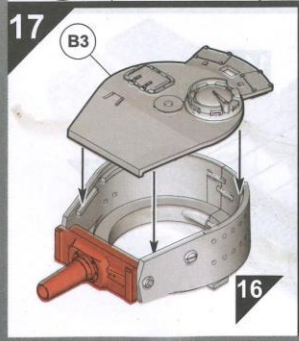
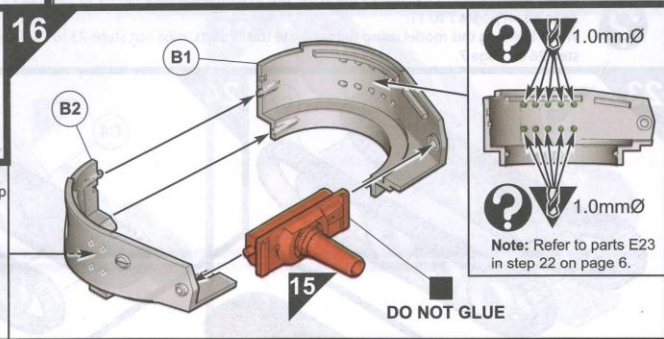
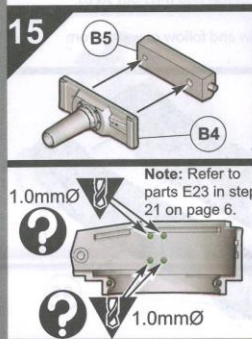
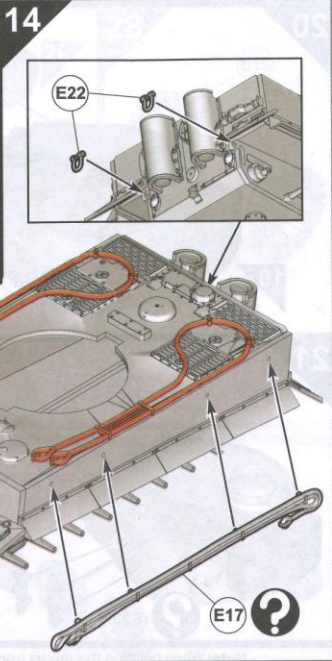
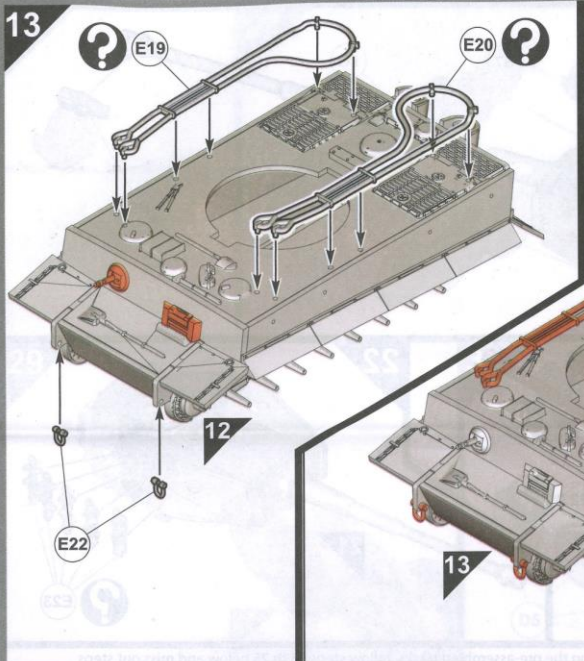

20

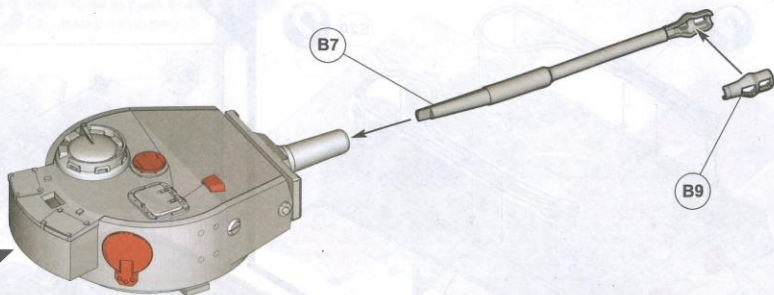

21

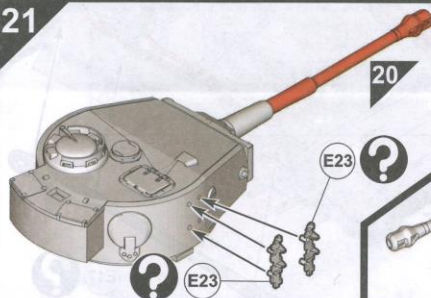

22

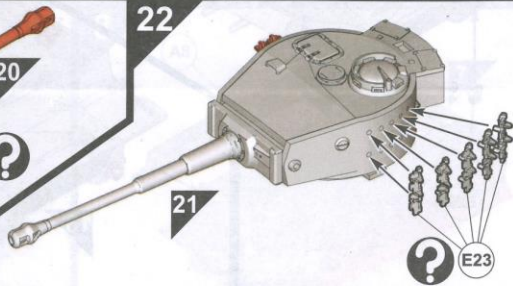

Note: When building this model using the pre-assembled tracks, follow steps 23 to 25 below and miss out steps 26 to 60 on pages 7 to 11.

When building this model using the separate tracks parts, miss out steps 23 to 25 below and follow onwards from step 26 on page 7.

23

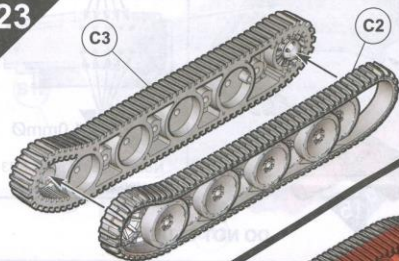

24

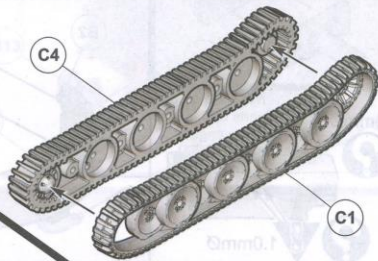

25

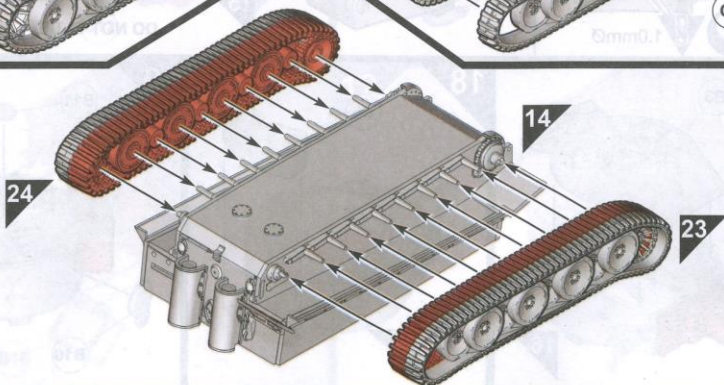

26

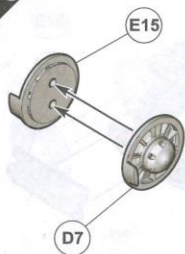

27

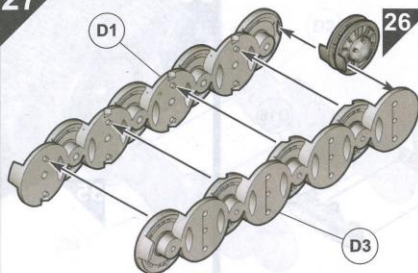

28

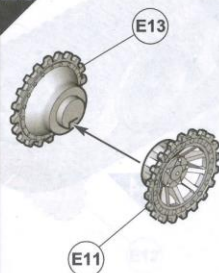

29

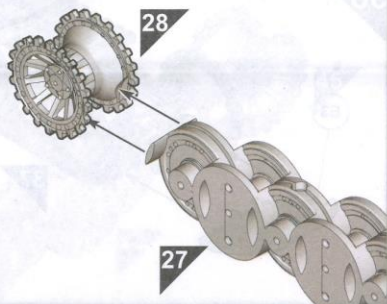

30

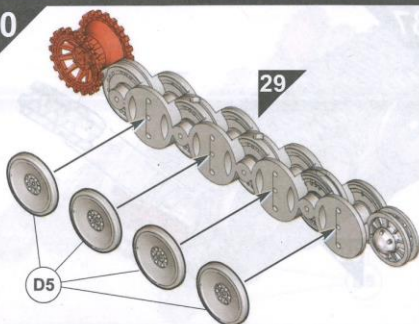

31

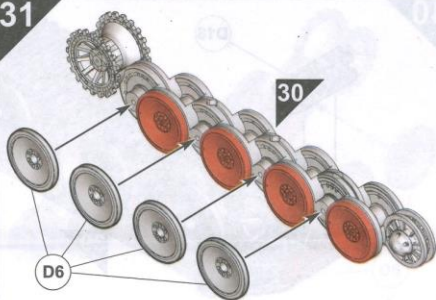

32

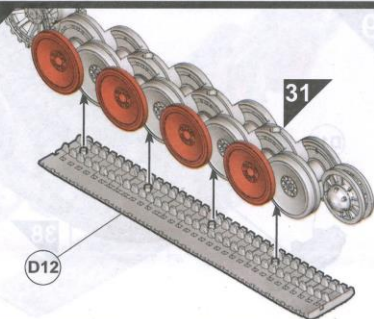

33

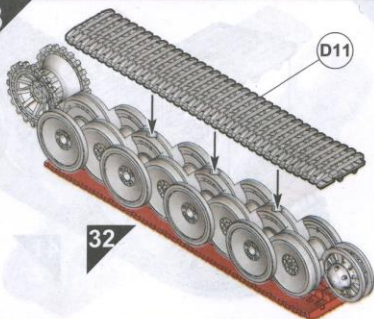

34

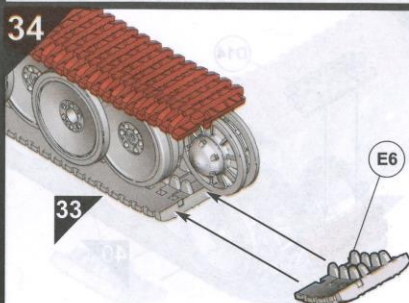

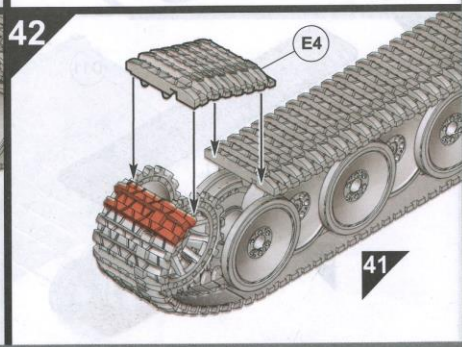
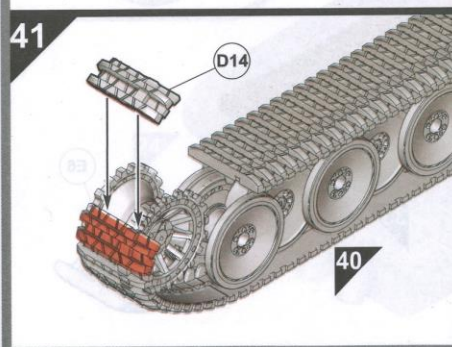
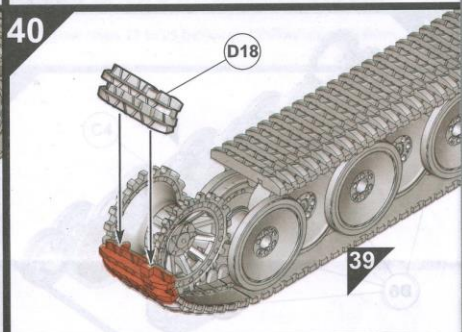
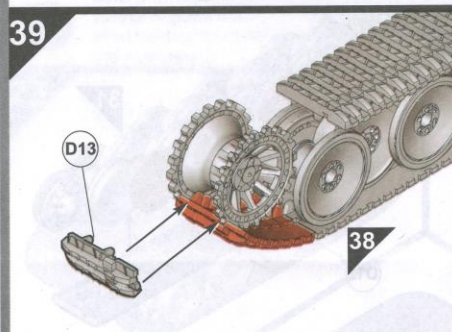
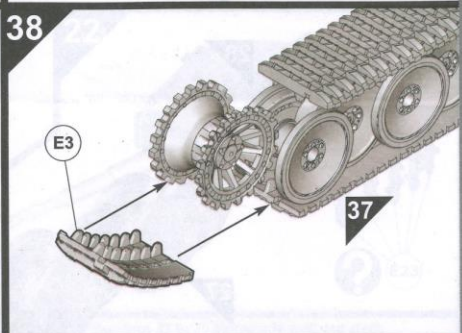
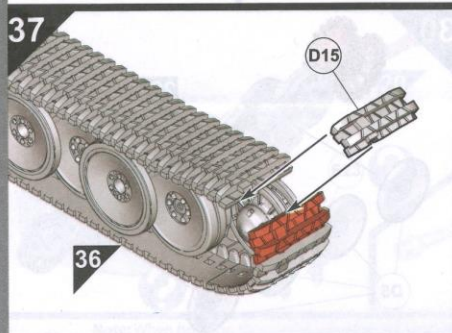
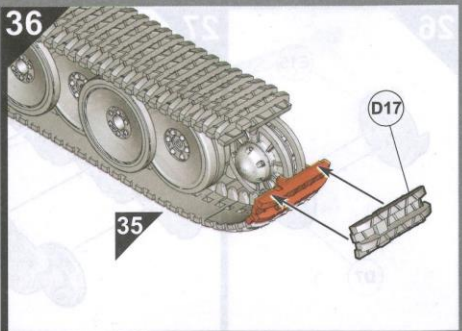
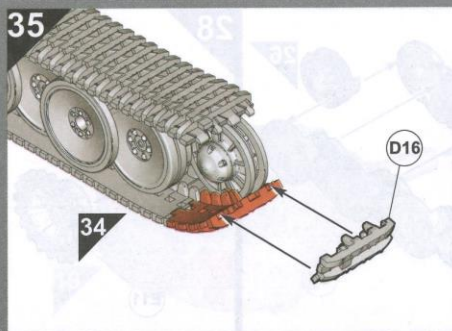

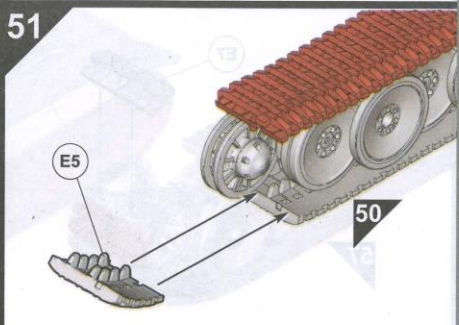
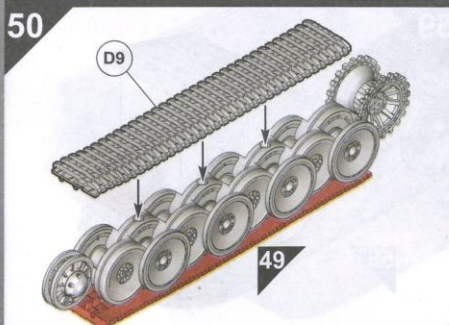
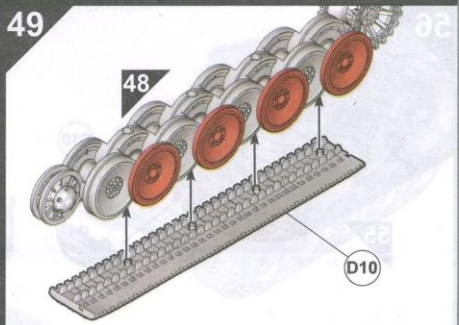
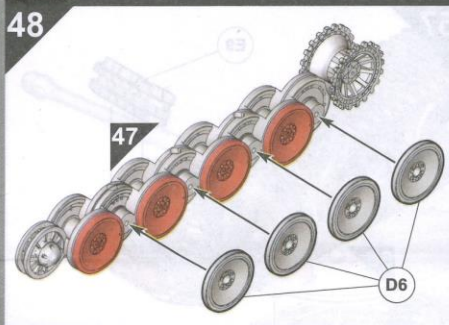
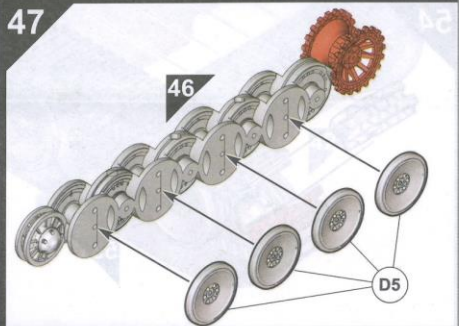
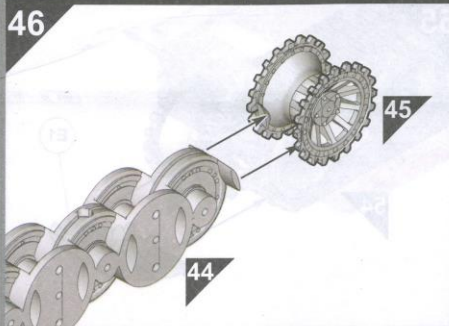
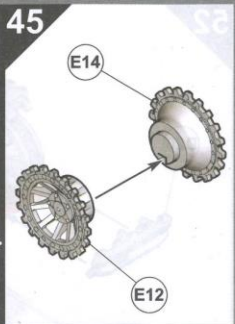
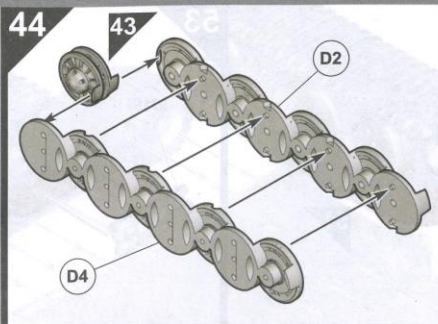
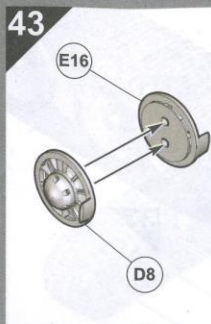

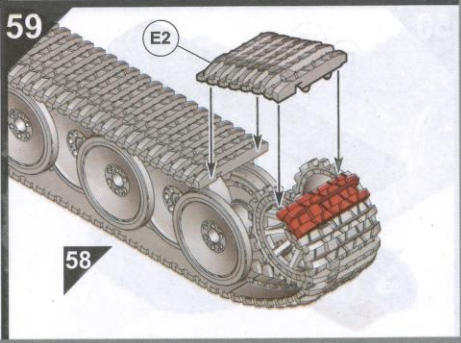
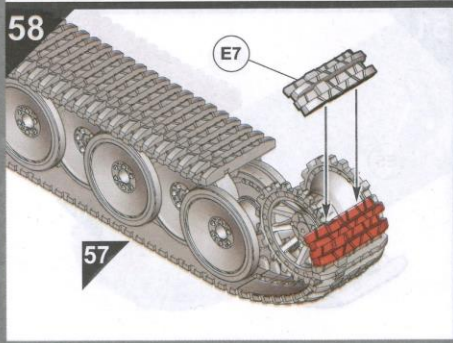
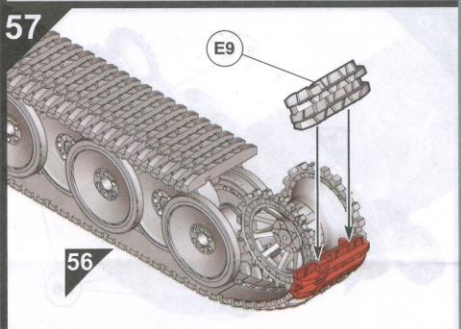
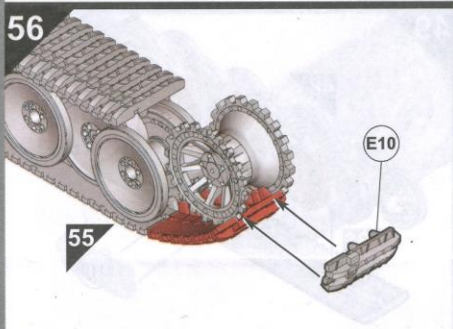
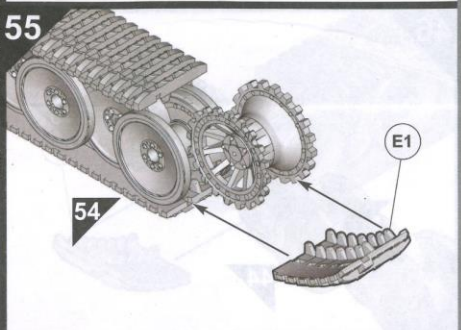
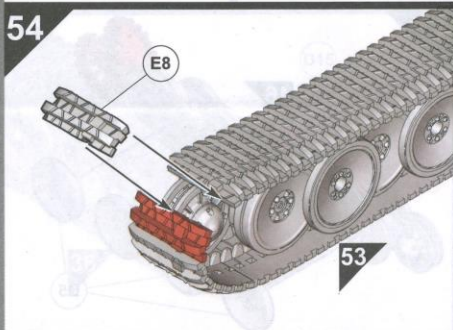
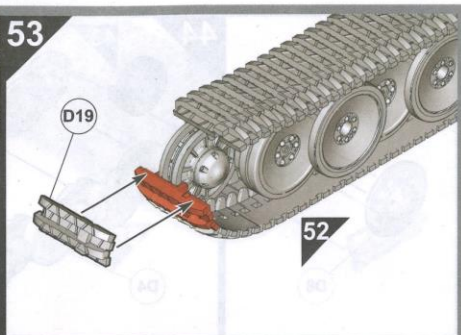
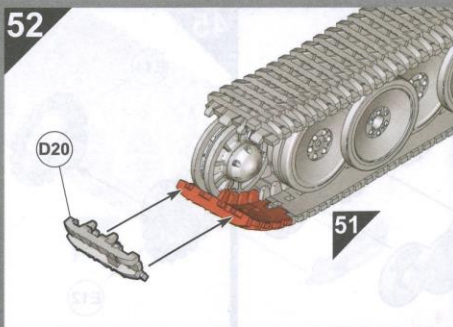

60

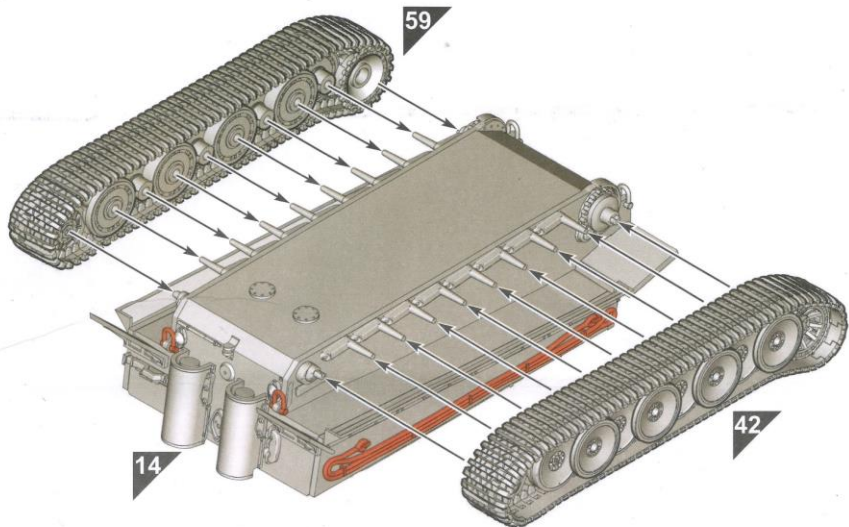

61

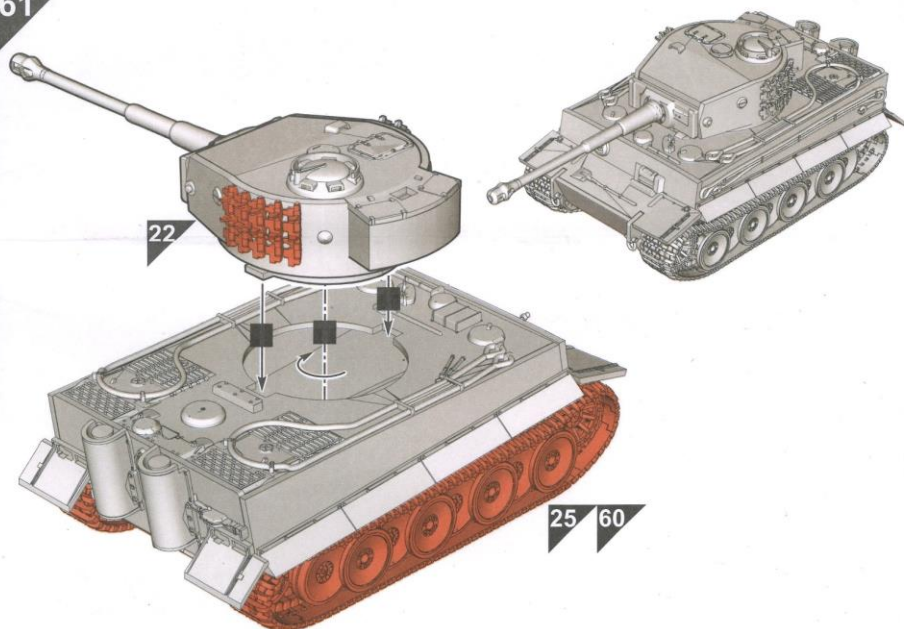

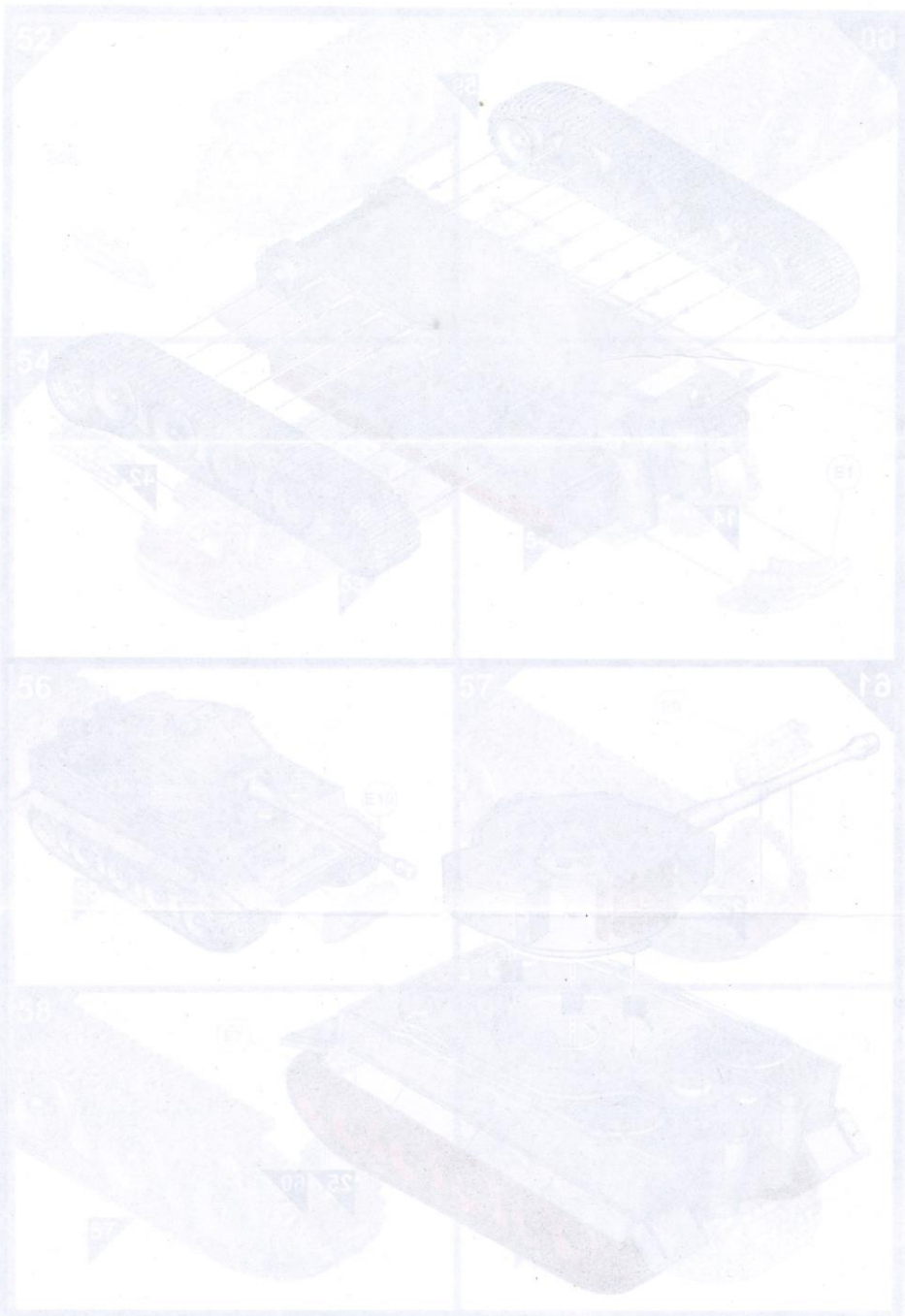

8 PzKpfw Tiger I auf E
 2. Kompanie, schwere Panzer-Abteilung 501, Byelorussia, 1943-44.

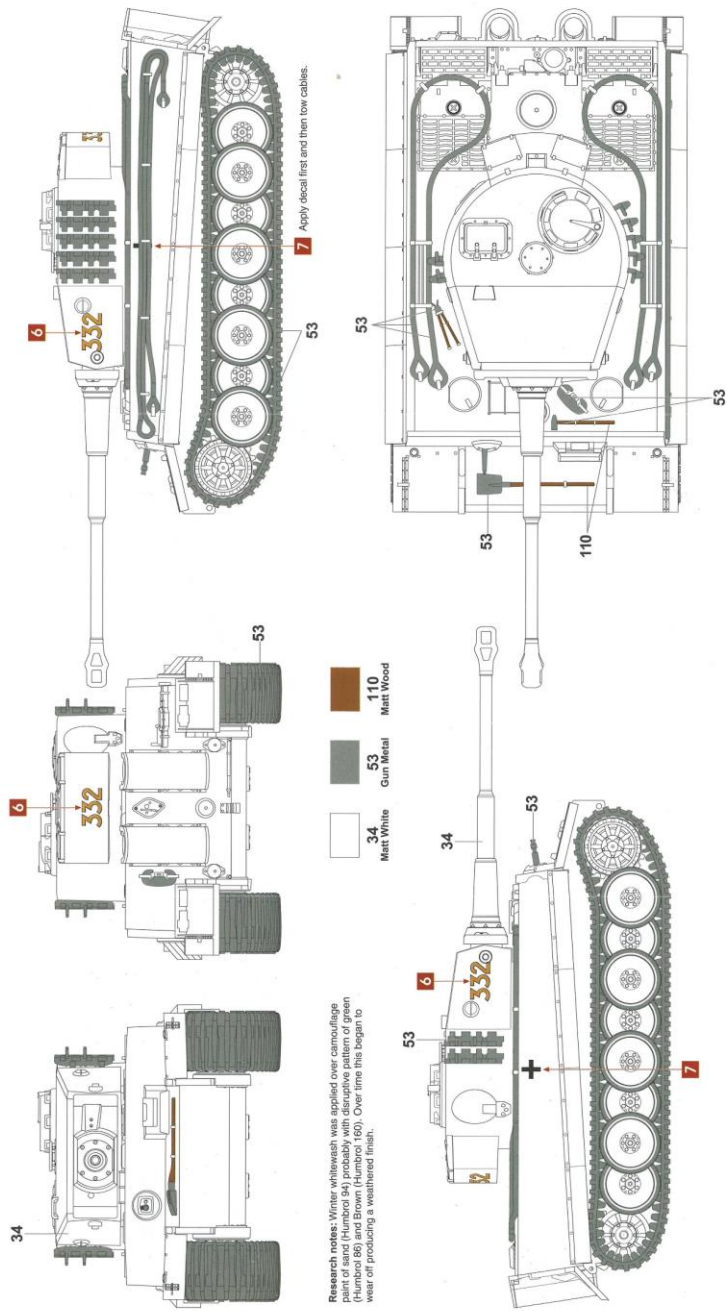

Ⓐ PzKpfw Tiger I auf E Commanded by Michael Wittmann, schwere Panzer-Abteilung 101, Normandy, France, 1944.

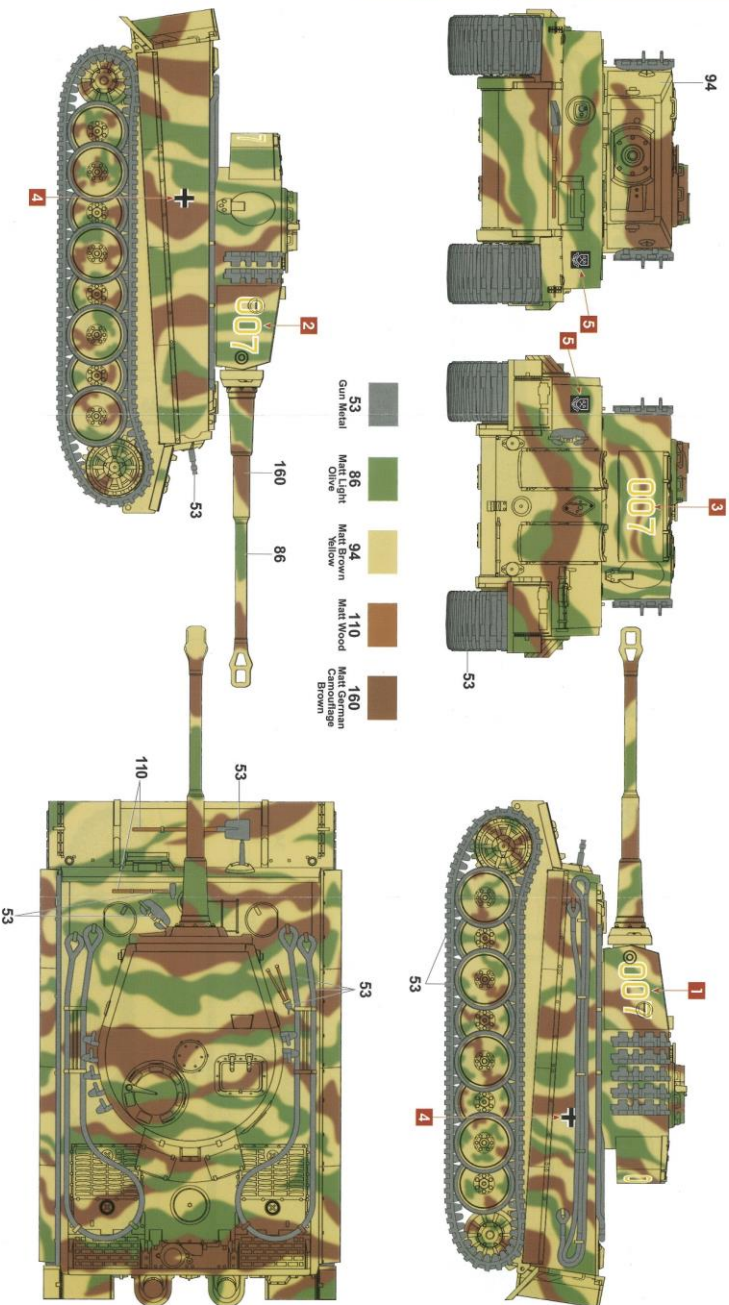

- 53 Gun Metal
- 86 Matt Olive
- 94 Matt Light Yellow
- 110 Matt Wood Brown
- 160 Matt German Camouflage Brown