

PYN-UP

Decals

Pick
Your
NoseART



PYND48040

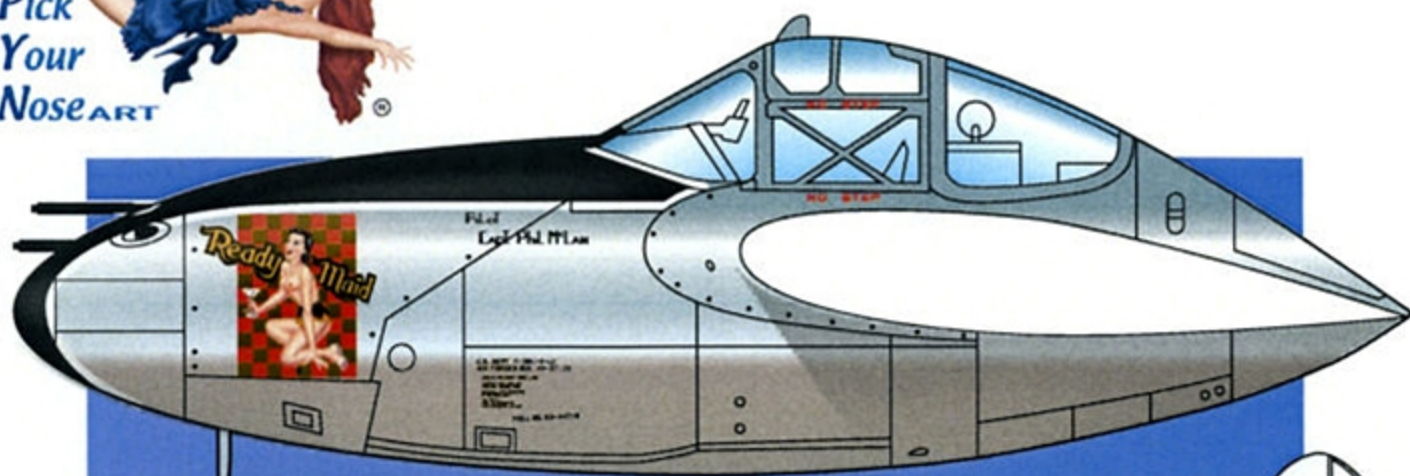

P-38L-5-LO
8 FG/36 FS

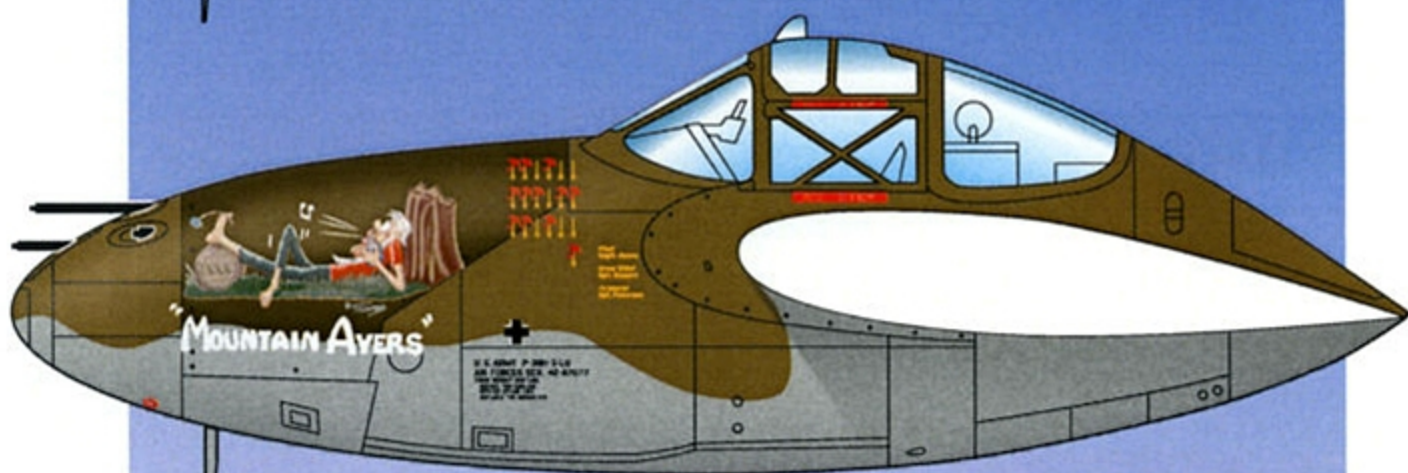
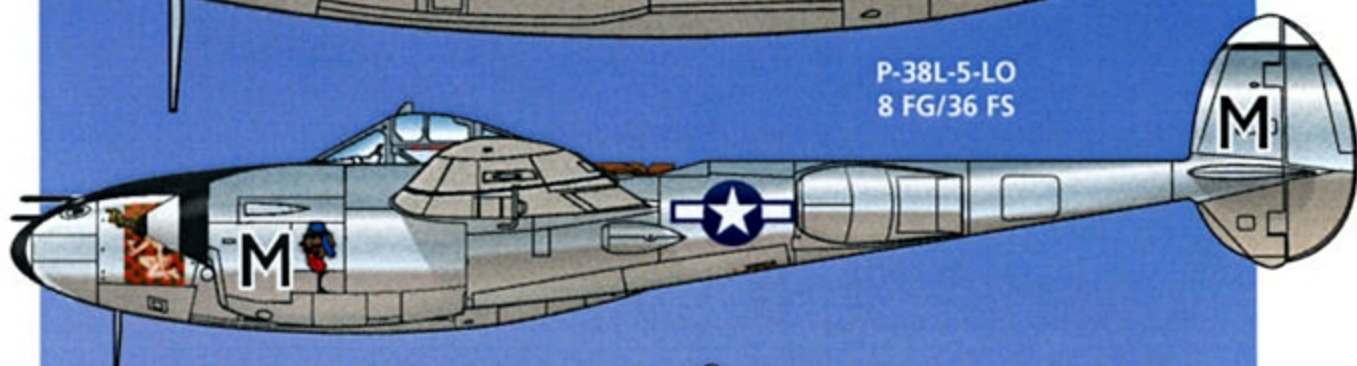

P-38H-5-LO
55 FG/38 FS

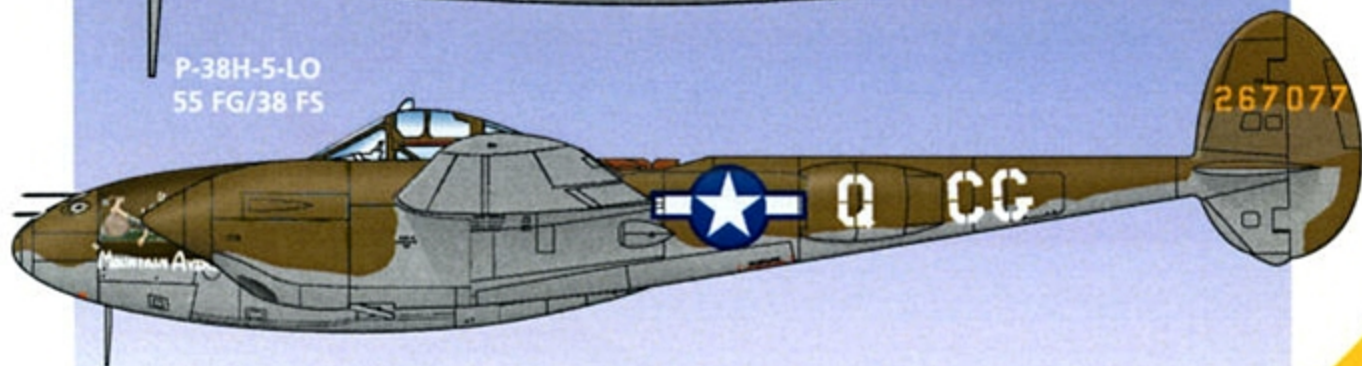

SPECIAL BENEFIT
for Meteor's Best
Customers!

**LIMITED EDITION
OF 300!**

Fork-tailed Beauties Part 5

PYN-up Decals

Pick
Your
NoseART



PYND48040

Only first column of umbrellas known for sure; other umbrellas are conjectural, so apply them as you wish

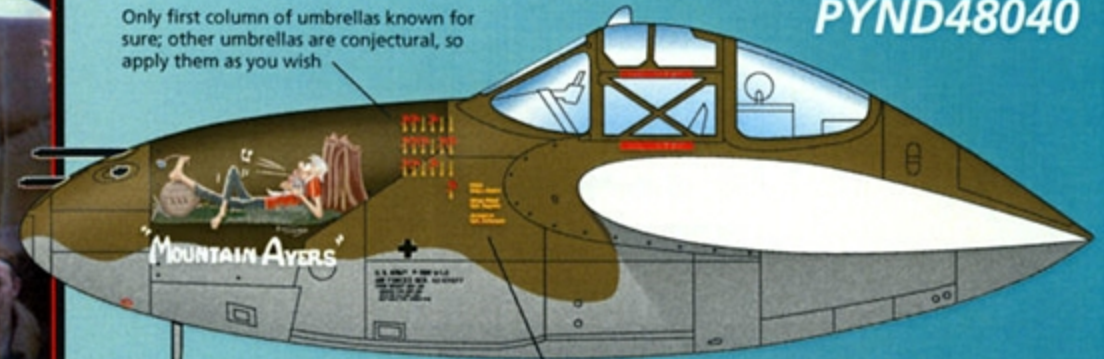

Wing tops

Red drop shadow on all letters.
Apply red decal first, then yellow.

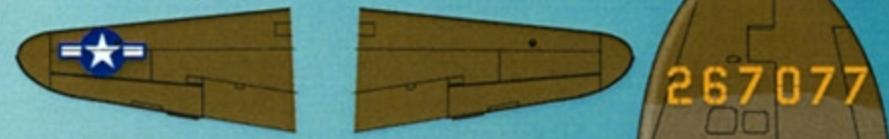

P-38H-5-LO
55 FG/38 FS

Capt Jerry H. Ayers
Nuthampstead, England
December 1943

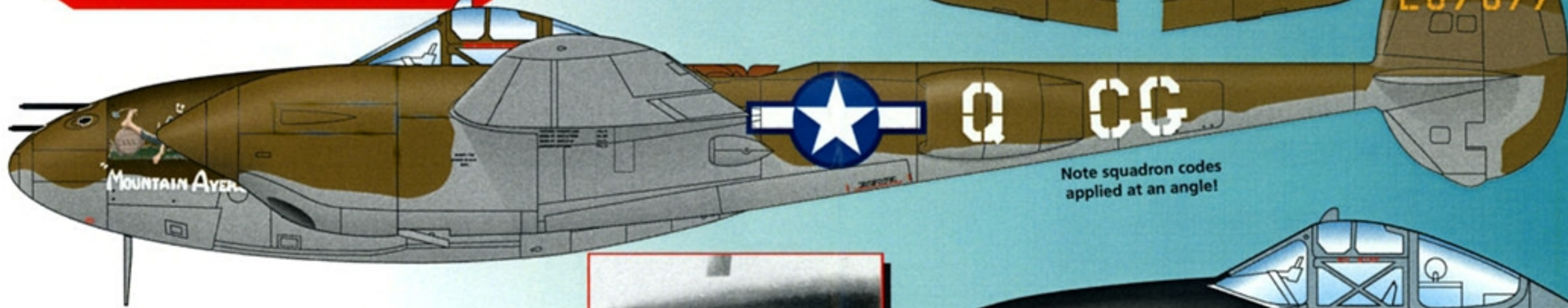

Note squadron codes
applied at an angle!

P-38L-5-LO
8 FG/36 FS

Capt. Phil McLain
Final scheme
Ie Shima
August 1945

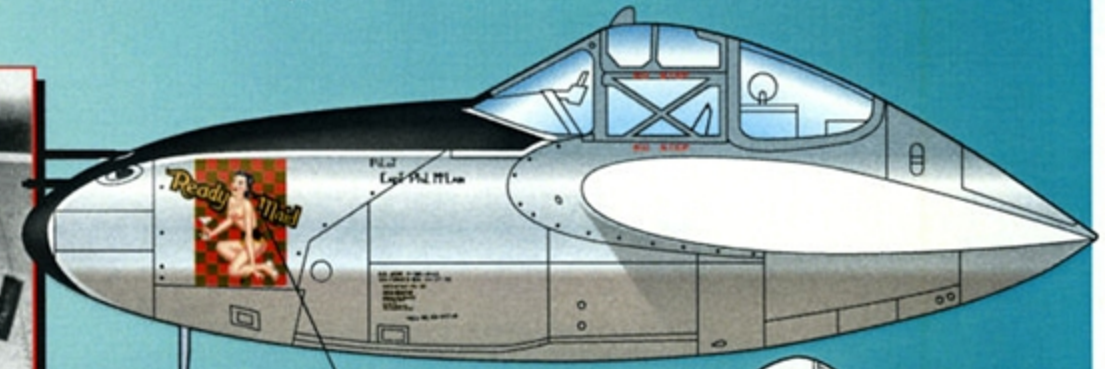

Note the checks along her
back were repainted incorrectly when
the name 'READY MAID' was added.

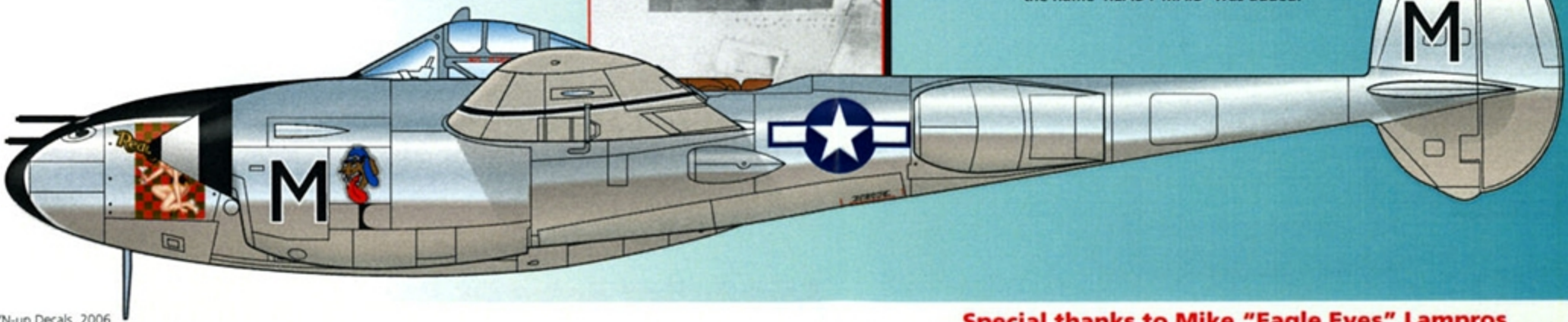

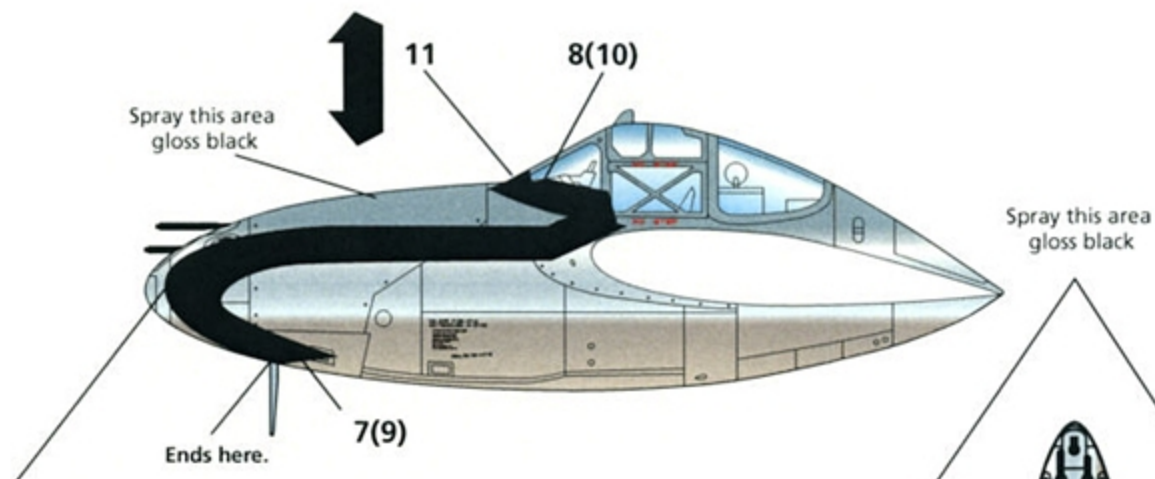

You have two options for painting the gloss black "antiglare" panels on Easy Maid.

If you paint the natural metal finish first, than the black panels:

You will mask over the silver finish and paint the black areas. Start at the top outside of the windscreen. Carefully guide the BlackMagic™ mask into place so it ends where the ventral antenna mast begins.

After the side masks (#8 & #10) are placed, add the windscreen mask (#11). It will overlay the side masks at its outside edges.

Because this is a flat piece of vinyl wrapping on a compound curve there will be some puckering along the outside edge of the masks. This is the side away from the paint edge and will not affect your masked line.

After the gloss black paint is completely dry, add the white pinstripe decals to the nose and nacelles.

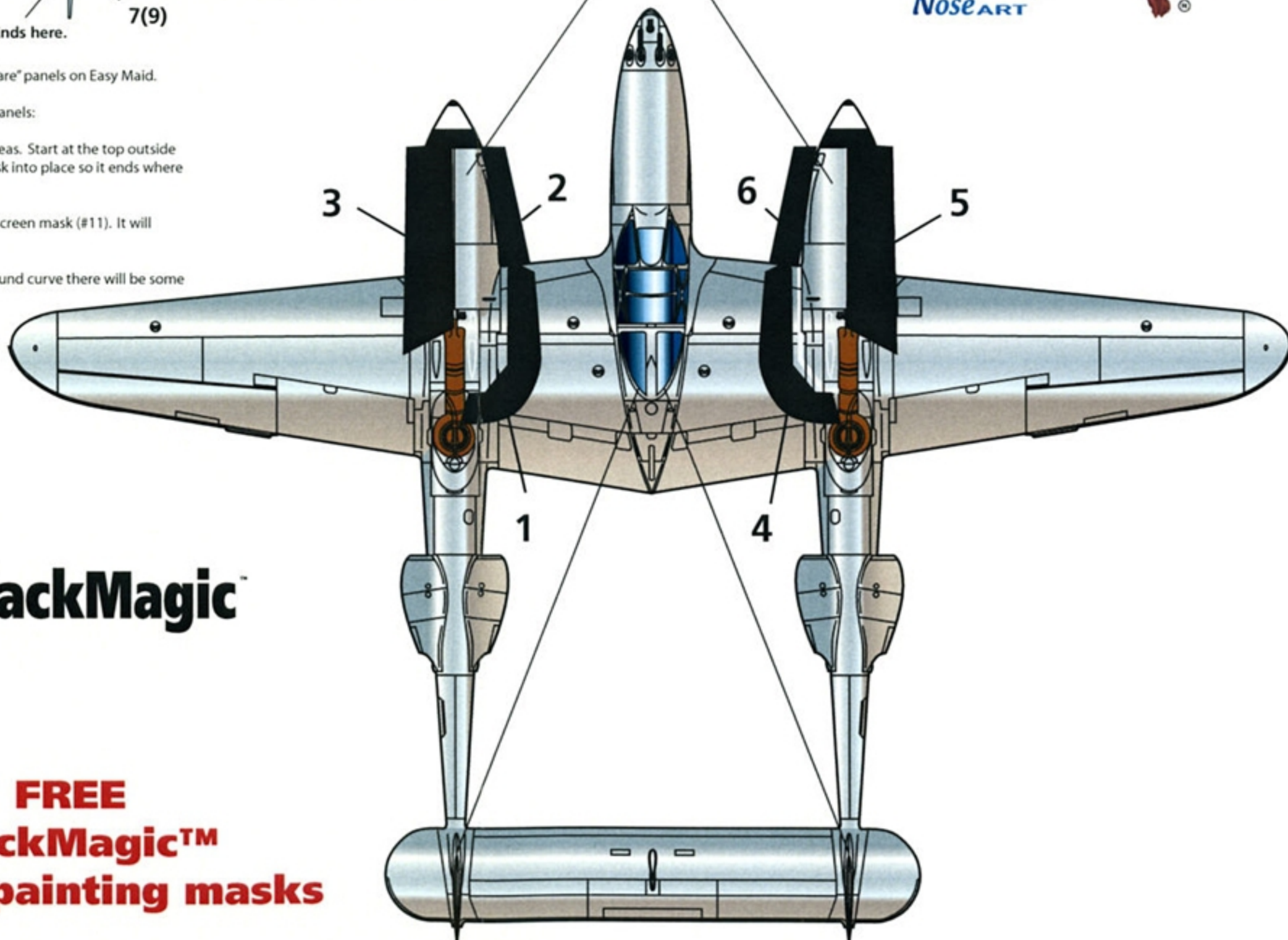

BlackMagic™

**FREE
BlackMagic™
precut painting masks**

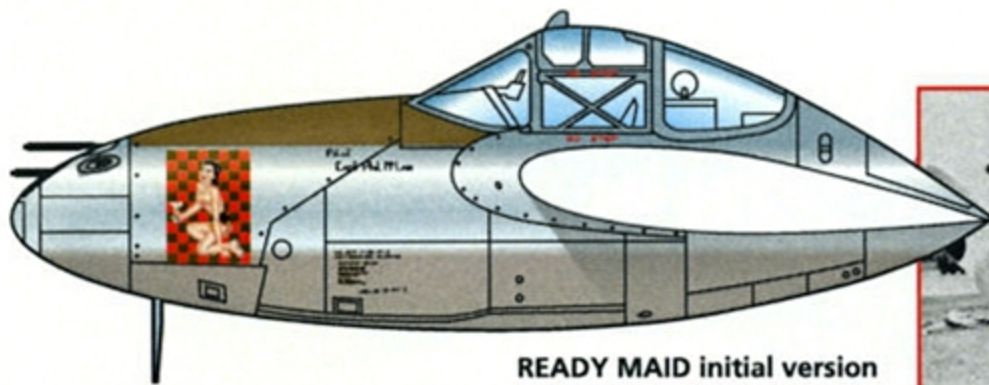

READY MAID initial version

- No name
- Olive Drab antiglare panels
- "M" on nacelles black only



Intermediate version

- Name added in yellow/black
- Checkerboard slightly revised
- Olive Drab antiglare panels
- "M" on nacelles black only

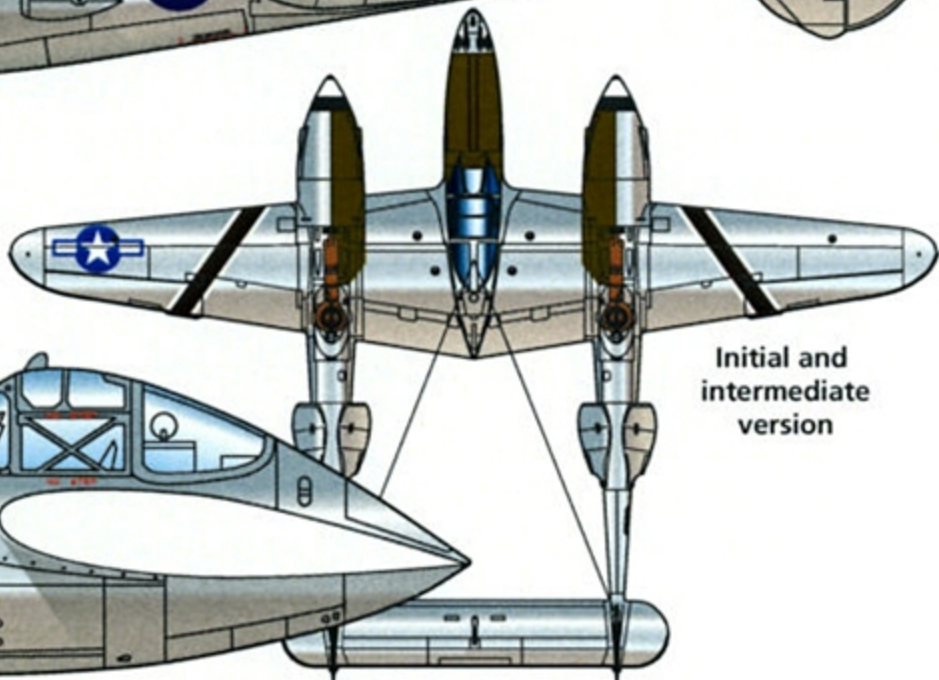

Initial and intermediate version

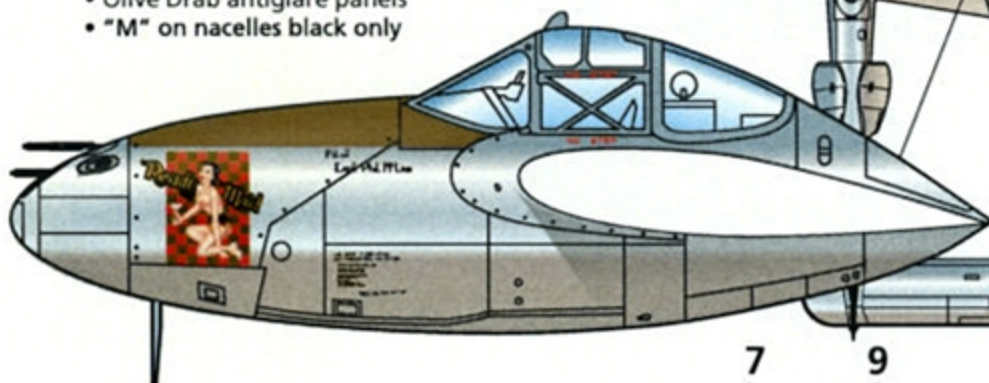

Final version
(see inside color page)

- Name still applied
- Antiglare panels changed to GLOSS black with white pinstripe outlines
- White outline added to "M" on nacelles

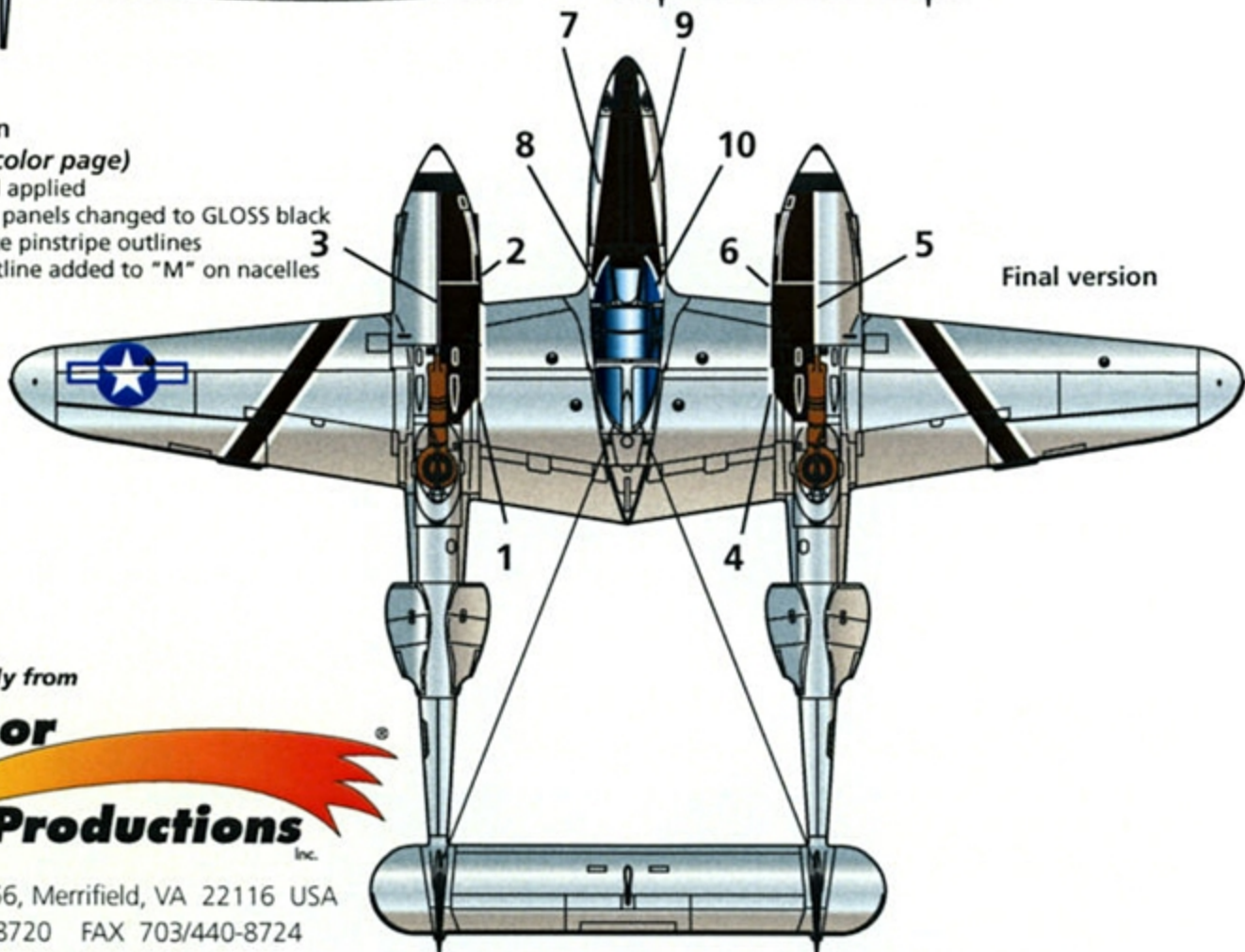

Final version

...available only from

Meteor



Productions
Inc.

P.O. Box 3956, Merrifield, VA 22116 USA

☎ 703/440-8720 FAX 703/440-8724

www.meteorprod.com

Applying the Specialty Nose Art

PYN-ups has supplied you with the thinnest possible decal material to create a true masterpiece on your model. Extra care is required when handling these decals! Because these decals are so thin, you may prefer to brush a coat of Microscale Liquid Decal Film over the top of the special nose art. This will dry in an extremely thin layer and will not add much thickness to our special decal.

After applying the white background decal from the main decal sheet, carefully trim around the nose art decal to separate it from the rest of the paper. Only use room temperature water. Do NOT leave the decal in the water by itself. The material will curl on you. Place the image in the water and hold the opposite edges down against the paper (either with your fingers or cotton swabs) and wait for the decal to separate from the paper. Once it has separated, the tendency to curl will have passed for the most part. Gently slide the nose art decal on top of the previously applied white background decal.

Mountain Ayers

- Ayres joined the 55th Fighter Group in May 1942 as part of the original contingent of pilots who shipped off to England in September 1943 to become the first P-38 unit in the 8th Air Force. He scored one victory, against a Bf 109 on November 29, 1943.
- His later claim to fame was as the pilot of one of the two P-38 "droopsnoots" used on the first operational droopsnoot mission on April 10th, 1944. Plagued by ear problems, his flying career was cut short and he left the Group in May 1944.
- Sgt Robert T. Sand, a member of the 55th prop shop, painted the "Mountain Ayres" artwork as a measure of his respect for Capt Ayres, who he much admired. Ayres, in turn, much appreciated the whimsical creation Sgt Sands painted for him. Fittingly, this artwork outlasted all of Sand's other amazing creations, which included Mark Shipman's "Skylark IV," Joe Myers' "Journey's End," and Jack Jenkins' "Texas Ranger," among others.
- Other pilots flew this ship after Ayres got a new plane, and eventually the artwork on the removable nose armament panel ended up on yet another plane that was credited with over 150 missions over enemy territory!
- The crew names block was yellow with a thin red drop shadow. Apply the red decal first, then apply the yellow decal slightly HIGHER and to the RIGHT (aft) of the red decal. Thus, the red drop shadow is below and to the left of the yellow names.
- Available photos do not indicate how many mission markings were carried on this ship; in fact, only part of the first column of markers are visible. We can see that all three of the brooms in the first column have the red umbrellas. The 38th Fighter Squadron usually showed six mission markers per row and surprisingly, the first marker was painted on the right and higher markers were painted to the left! We have shown 19 missions in this layout and randomly chosen locations for the red umbrellas (other than the first column, which we know had the umbrellas). We know at least 18 missions were shown in this painted record (three rows of six, starting on the RIGHT side and moving to the left), so you can make your own guesses as to which brooms also had umbrellas if you wish.
- The original national insignia on this ship was the simple blue/white cocarde with star. Later the bars were added and the entire insignia outlined in red, and shortly thereafter the red was changed to fresh Insignia Blue. We've provided both red and blue outlined versions on our decal sheet.
- Note the squadron code letters, "CG," were applied at a noticeable up angle, such that the centerline of the squadron code was parallel to the centerline of the boom itself. Most 38th FS aircraft had these code letters applied parallel to the direction of flight, and in fact the individual code letter, "Q," was applied parallel to the line of flight.

Ready Maid

- Although the 8th Fighter Group was only based at Ie Shima for a short time before the war ended, nobody can claim they didn't sport some of the most colorful and striking nose art seen in the Pacific Theater! Ready Maid is one of the finest examples of this creativity; unfortunately the artist is not identified and little other information is available about the plane and pilot.
- The colors of the checkerboard behind the female figure has been an issue of great interest and discussion. Originally we believed it was probably red and black, but photos clearly show the black outline to the words "Easy Maid" to be much darker than the darkest checks. Neither can it be yellow and black (or red) as the female figure is much brighter than either of the checkerboard colors. After considerable discussion and comparison among the available photos and with color photos of other ships in the group painted by the name nose artist, we believe the checkerboard colors were olive and red. This color combination, verified by color

- photos, was definitely used on "Wicked Woman," and comparison with black and white photos of that plane gives similar tonal values to the checkerboard on Ready Maid.
- You can depict your model in any of the three markings periods documented for this plane...although since the 8th was on Ie Shima for a fairly short period presumably none of these schemes could have been very long lived!

- Initial version:
 - Female figure on checkerboard background, but no name applied
 - Wing bands applied (squadron identification marking)
 - Olive Drab antiglare panels on the fuselage and booms
 - Plain black "M" code letters on the booms and fins
 - Unknown whether the squadron insignia was applied to the boom during this period, but it probably was
- Intermediate version:
 - Female figure on checkerboard background; name applied in yellow and black
 - Wing bands applied
 - Olive Drab antiglare panels on the fuselage and booms
 - Plain black "M" code letters on the booms and fins
 - Squadron insignia probably applied to booms
- Final version:
 - Female figure on checkerboard background; name applied in yellow and black
 - GLOSS black overpaint to the fuselage and boom antiglare panels, with the black extending over the front of the nose cap to the under-fuselage radio antenna, all outlined with white pinstripping
 - Wing bands applied (squadron identification marking)
 - White outline added to "M" code letters on booms and fins
 - Squadron insignia definitely applied to booms

Applying the Decals

You probably already know all this stuff, so feel free to use your regular process; however, if you're new to aftermarket decals, here goes:

- Generally, use the Microscale Finishing System. We don't recommend extremely strong decal solvents such as Solvaset.
- Your model must have a smooth, glossy surface, as decals won't adhere well to matte surfaces. Use gloss paints or your favorite clear gloss overspray over matte or semigloss paint.
- Cut each subject out without trimming off the slight excess film (this helps the decal film disappear when dry).
- Put the decal in warm water that has a drop or two of liquid dishwashing soap or photo-flo for 10 seconds.
- When the decal will slide off the backing paper without forcing it, apply it to the proper position on your model. Slide the backing paper out from underneath.
- Gently blot off excess water and smooth out bubbles under the decal surface. If you wish, carefully brush on a mild decal softener such as Micro-Sol.
- When all decals are completely dry, gently wash off all excess decal adhesive.
- Finally, overcoat your model with a good quality gloss coat, followed by your choice of matte or eggshell clear topcoat.

FS 595 Color Cross Reference

Olive Drab	FS 4087 Xtracolor X111, Floquil 303108/303170/303263, Gunze Sangyo H304, Modelmaster 1711, Mr Color 304, Pro Modeler 88-0028
Neutral Gray	FS 6173 Xtracolor X158, Gunze Sangyo H053, Pro Modeler 88-0035, Floquil 303176

Bibliography

American Eagles: P-38 Lightning Units of the Eighth and Ninth Air Forces, by Roger Freeman. Classic Publications, 2001.
 Attack and Conquer, The 8th Fighter Group in World War II, by John Stanaway and Lawrence J. Hickey. Schiffer, 1995.
 Double Nickel, Double Trouble, by Robert M. Littlefield. Published privately, 1993.
 Fighter Command, by Jeffrey L. Ethell and Robert T. Sand. Motorbooks, 1991.
 Replica in Scale, Vol 2, No. 2, Winter 1974.
 The 55th Fighter Groups vs. The Luftwaffe, by John M. Gray. Specialty Press, 1998.
 The Mighty Eighth Warpaint & Heraldry. Roger A. Freeman. Arms & Armour Press, 1997
 Warpaint: Fighter Nose Art, by John M. Campbell and Donna Campbell. Motorbooks, 1990.