

# Camouflage & Decal application

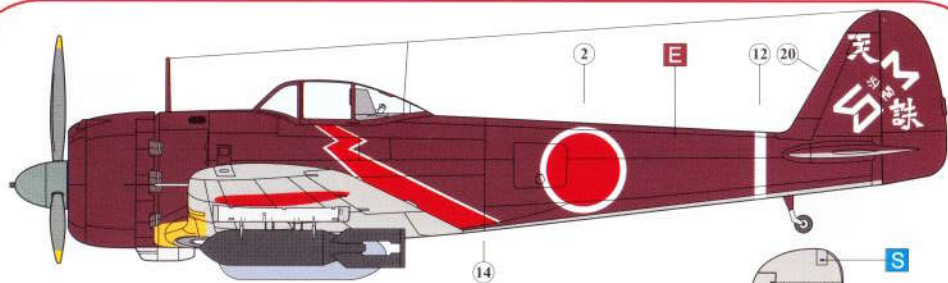

Ki 43-III Ko, flown by the commander of the 53rd Shinbu Tai 2nd Lt. Mitsuo Chikama, Chiran air base, Japan, May 18, 1945. His eight-ship formation took off from Chiran for an attack against ships near Okinawa on May 18, 1945. The underwing racks carry a 200l fuel tank and a 250kg bomb. The tail sports stylized "53" small characters in the centre are the pilot's surname. The larger characters on the tail denotes the unit's name - Tenchū (punishment in the name of God). In the Edo era criminals were beheaded while hearing "this is the punishment in the name of God".

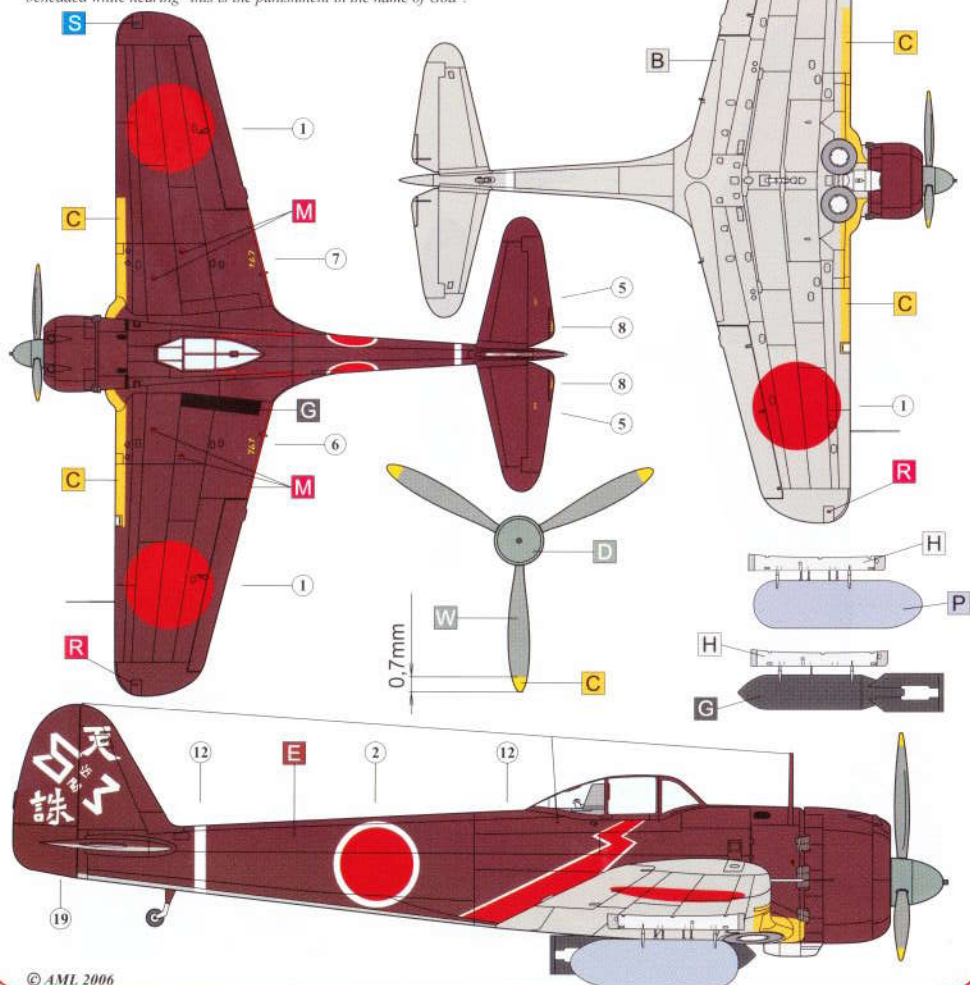

# Nakajima Ki 43-III Ko Hayabusa / "Oscar"

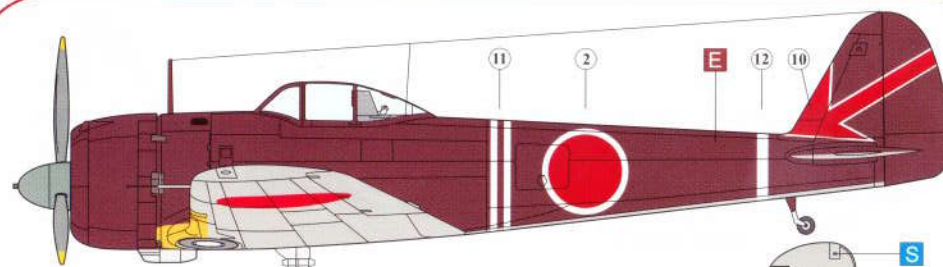

Ki 43-III Ko, 64th Sentai, flown by Capt. Hideo Miyabe in autumn 1944 when he was a Hikōtaichō, Burma. The two characters on the fuselage read "Aso" which is a mountain located near Miyabe's birthplace. The nonstandard upper exhaust stack identifies an aircraft from the earliest production batch of the Ki 43-III Kō, as it was typical of the Ki 43-II Kai variant.

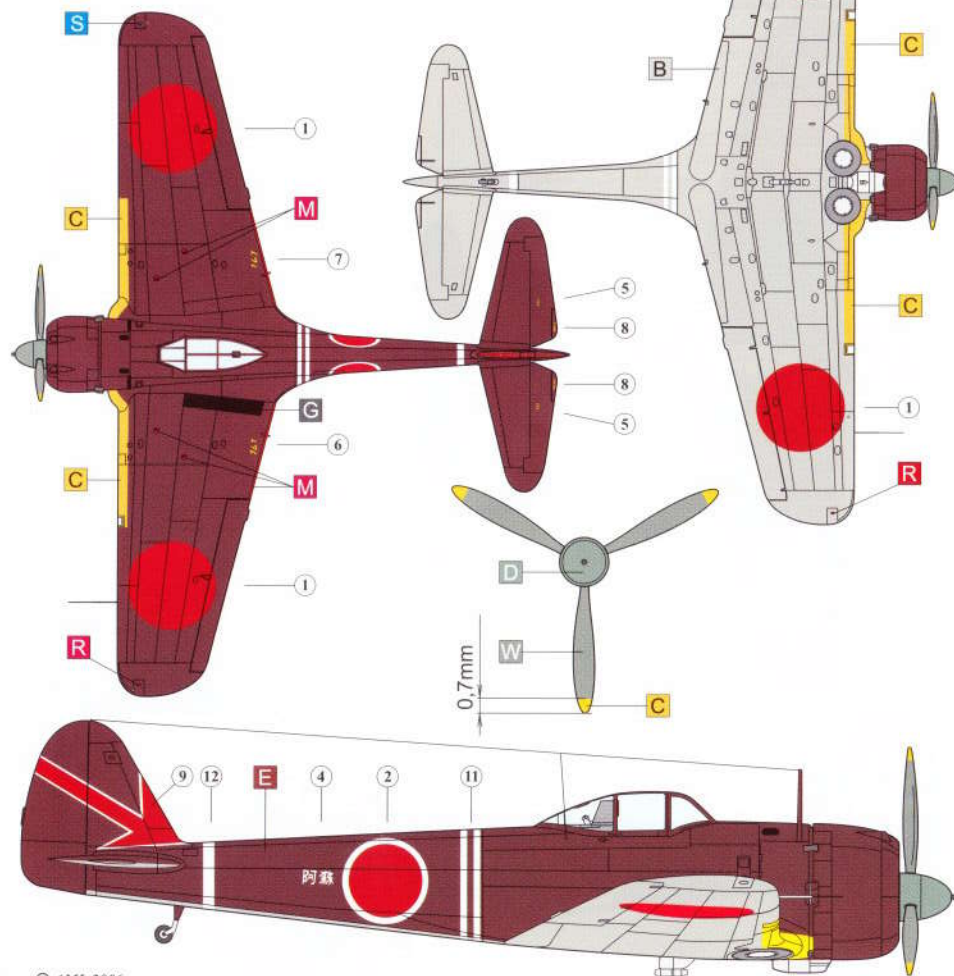



## Camouflage & Decal application

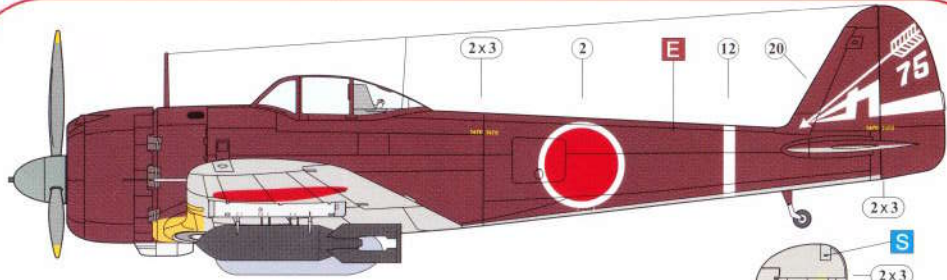

Ki 43-III Ko, flown by 1st Lt. Tōru Shinomiya, CO of the 19th Shinbu Tai, Chiran air base, Japan, late March 1945. This suicide attack unit was formed on February 20, 1945, and it took off for its final mission in two formations from Chiran on April 29 and May 5. The first formation heading towards Okinawa was led by Shinomiya. He originally served with the 244th Sentai where he was a member of the Shinten Seikū Tai (units which specialized on ram attacks on high flying B-29s). He received the Bukōshō Order Otsu Class for ramming a Superfortress on December 3, 1944. After the accomplishment of his suicide mission he was posthumously promoted by two grades to major.

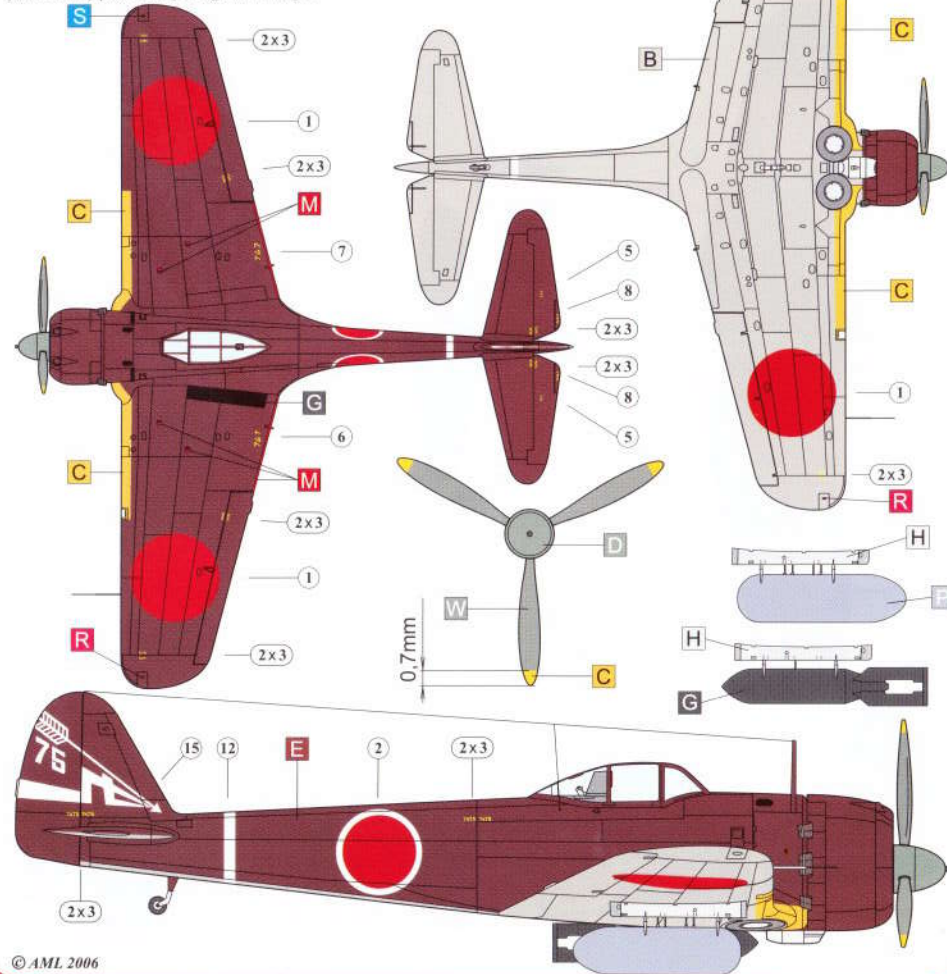

## Camouflage & Decal application

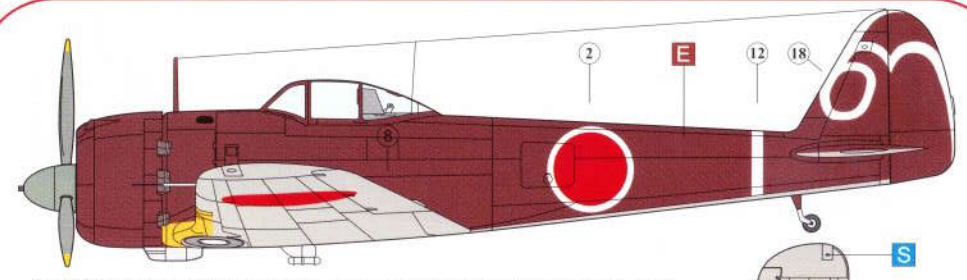

Ki 43-III Ko, 65th Sentai, Metabaru air base, Japan, August 1945. The 65th Sentai was a less known operators of the Hayabusa. It was not a fighter unit, as it used Kawasaki Ki 48 light bombers during the whole war. At the end of the war the unit's Ki 48s took part in the defense of the Philippine. After that the light bombers were replaced by Hayabusas which were to be employed in the fighter bomber role. In the closing months of the war the 65th Sentai operated Chiran and Metabaru airfields in the south of Kyūshū.

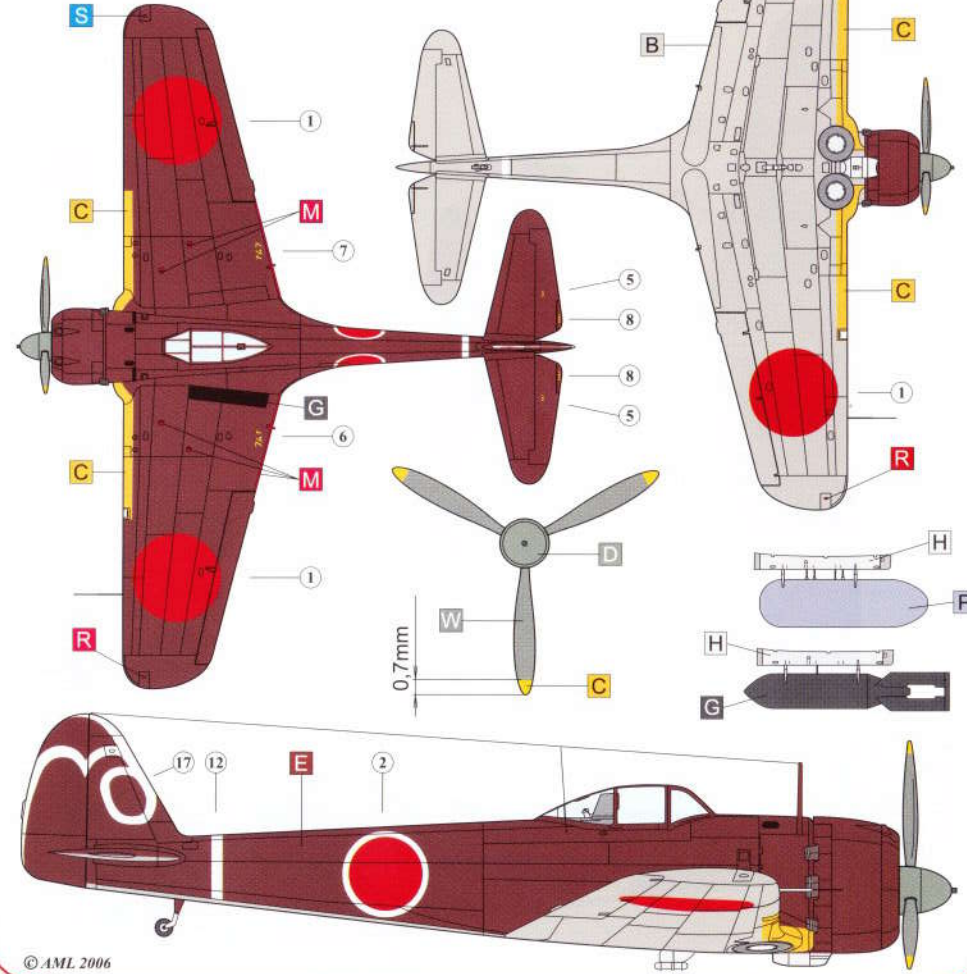

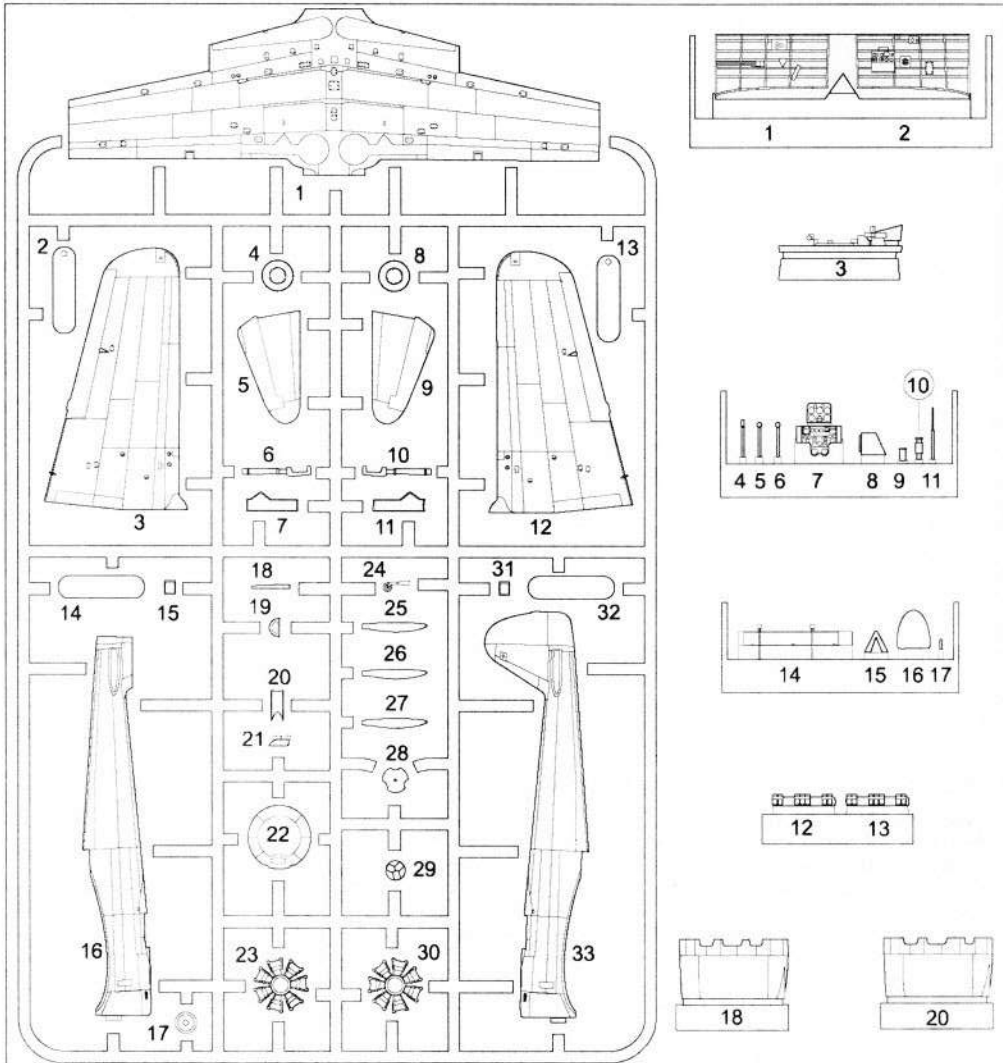

- Grind
- Optional
- Remove
- To make

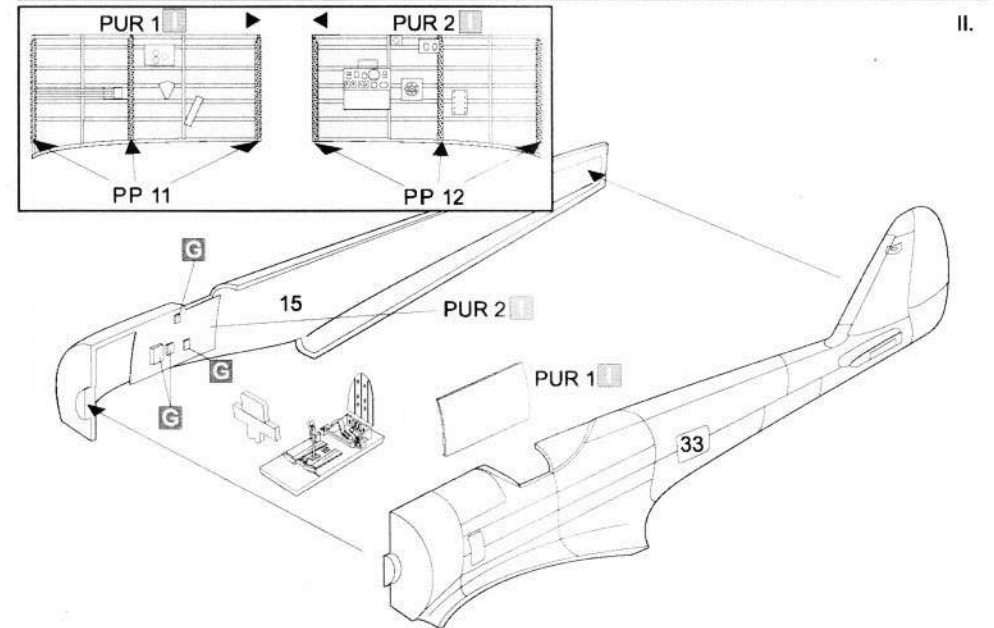
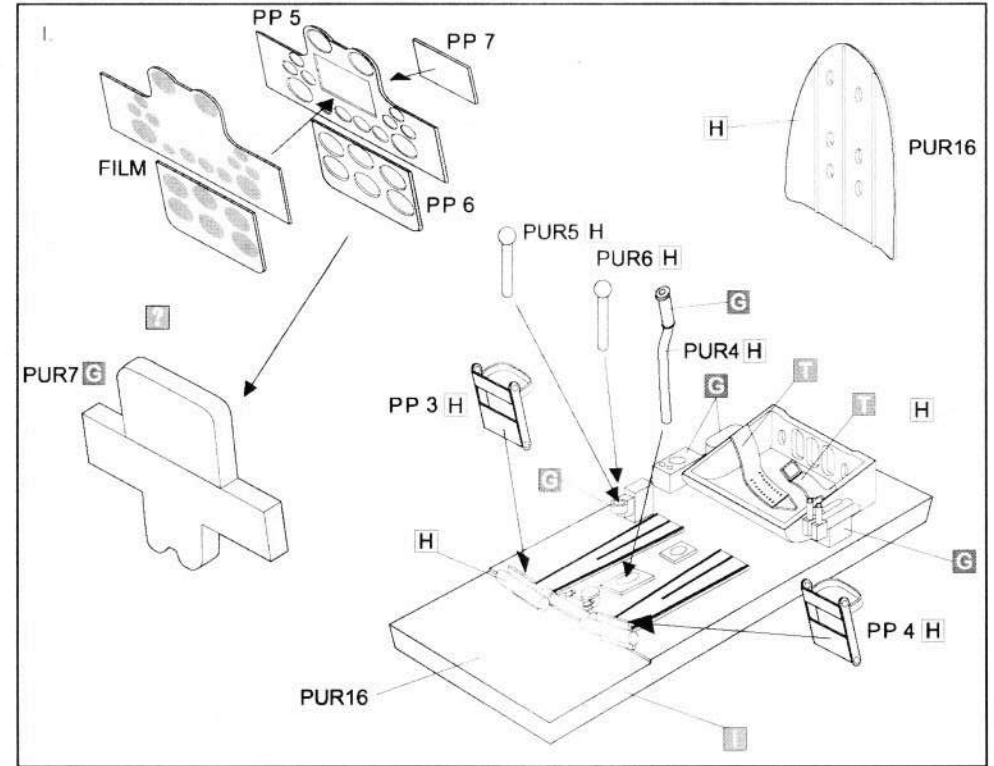
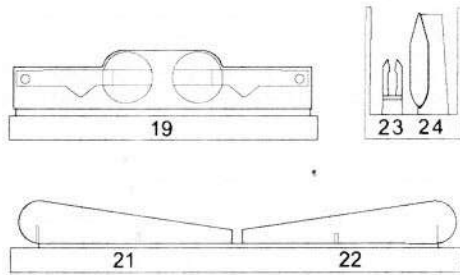
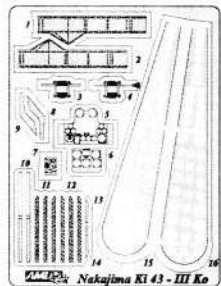

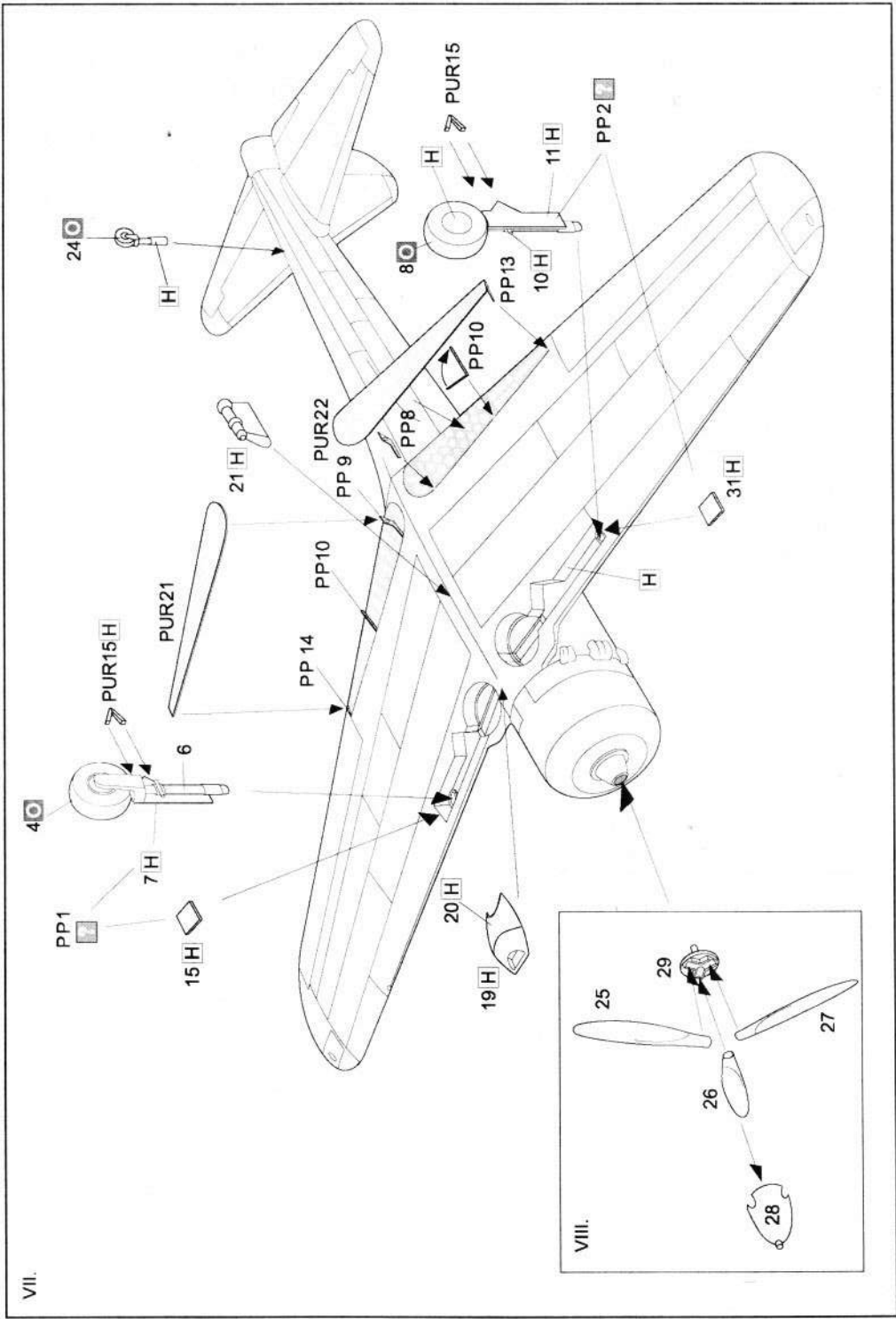
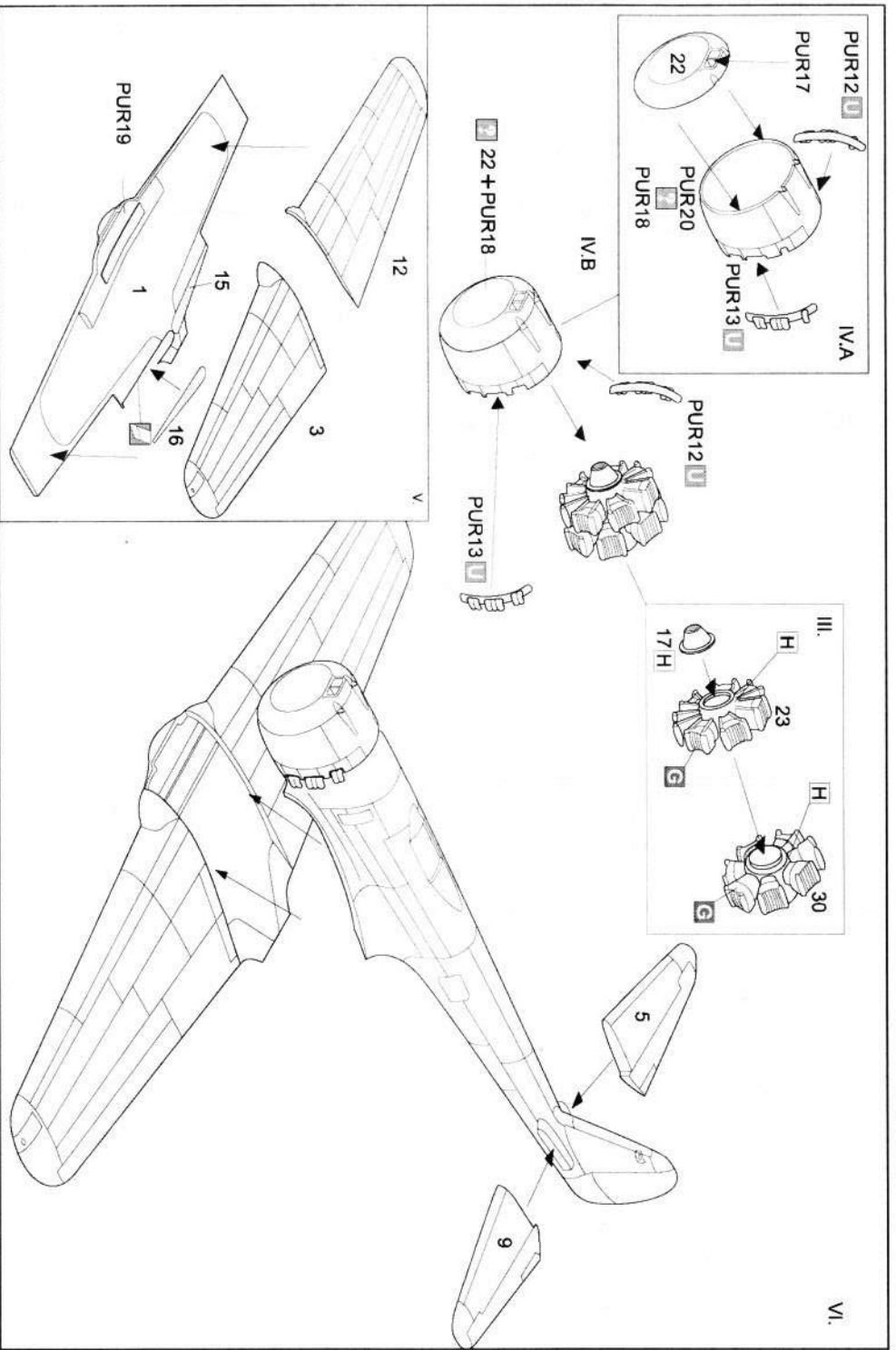



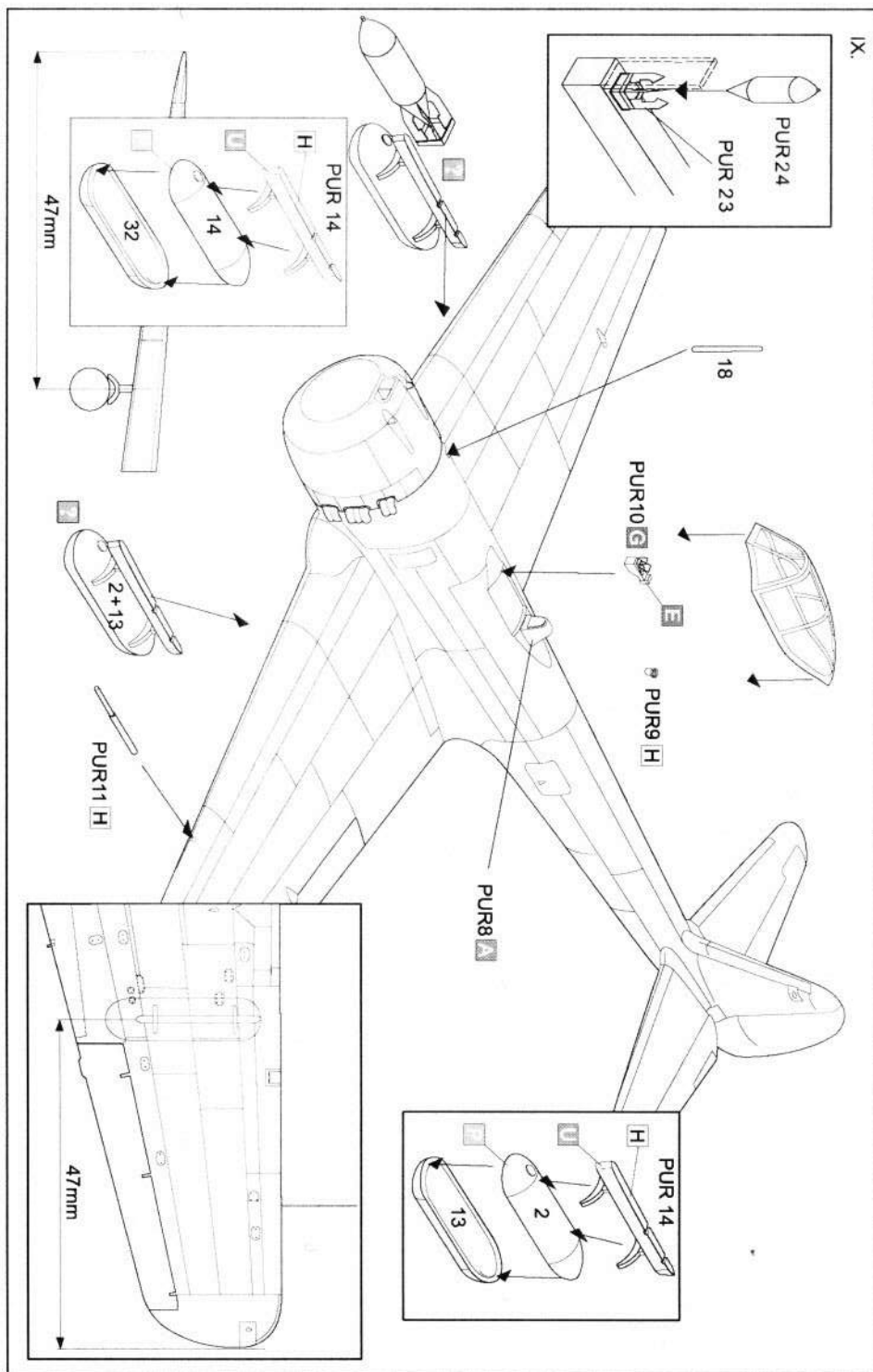

## Doporučené barvy

### Recommended Colours

	F.S.	Humbrol	Gunze Sangyo	LIFECOLOR	Agama
A Olive Green	4088	H 155	H 52	UA003	A47
B Light Grey	6424				
C Orange Yellow	2246	H 18	H 24	LC 55	16
D Green Grey	5414		H 48	UA062	
E Red Brown	3011		H 47		
F White	7878	H 34	H 11	LC 01	01
G Black	7031	H 33	H 12	LC 02	07
H Silver	7178	H 11	H 8	LC 74	8
I Metallic Blue Green			H 63		
J Gunmetal		H 53		UA 76	32
K Steel			H 18		57
L Burnt Iron		H 113	H 76	UA061	29
M Red	1136	H 153	H 327		A49
O Tire Black			H 77		J18M
P Grey			H 70	UA071	
R Clear Red			H 90		
S Clear Blue			H 93		
T Khaki		H 26	H 81		C19
U Wood Brown		H 10	H 37	UA085	35
Propeller Colour			C 131		

NOTE: This above list refers to Federal Standard /FS 595A / numbers do not include the prefix number. This just denotes the sheen of the colour e.g. 1= Gloss, 2= Semi-gloss, 3= Matt.

Thank Mr. Petr Klajmon, Mr. Martin Ferkl and the Revi magazine for help with gathering the necessary archive documents.

## Doporučená literatura, webové stránky

Nakajima Ki 43 Hayabusa "Oscar"  
 Nakajima Army Type 1 Fighter "Hayabusa"  
 Nakajima Ki 43 Hayabusa "Oscar"  
 Nakajima Ki 43 Hayabusa "Oscar"

<http://www.j-aircraft.com/index.htm>  
[http://www.ipmsstockholm.org/magazine/1997/02/stuff\\_eng\\_oscar.htm](http://www.ipmsstockholm.org/magazine/1997/02/stuff_eng_oscar.htm)  
<http://www.ipmsstockholm.org/colorcharts/colorcharts.asp>

## References

Aero Detail, No. 29  
 Famous Airplanes of The World, No. 65  
 W. Pajdosz, M. T. Włodarczyk, A. Jarski, AJ PRESS, No. 48  
 P. Skulski, ACE PUBLICATION, No. 11

## Návod na aplikaci vodou snímatelných obtisků / How to apply Decals

1. Vystříhnete pečlivě požadovaný objekt z obtiskového aršíku.
2. Namáčejte asi 10 vteřin ve vlažné vodě, až podkladový papír nasaje dostatečně vodu.
3. Položte navlhčený obtisk na nesavý podklad a nechte působit asi 1 minutu, až se uvolní lepidlo a obtiskem lze po podkladovém papíru lehce posouvat.
4. Umístěte obtisk i s podkladovým papírem na požadované místo na modelu. Přidržte obtisk pinzetou a opatrně z pod něho vytáhněte podkladový papír. Pokud se Vám nepodařilo umístit obtisk přesně na požadované místo, naneste kolem okraje obtisku štětcem trochu vody. Voda zavzlíná pod obtisk a můžete pak jemně pinzetou upravit polohu obtisku na modelu.
5. Je-li obtisk na požadovaném místě, pak ho opatrně přitiskněte jemným hadříkem tak, abyste vytlačili všechnu vodu a případné vzduchové bubliny.
6. Pro sjednocení povrchu modelu a zamezení případného pozdějšího odlepování obtisků je vhodné celý povrch modelu přelakovat vhodným průhledným lakem.

1. Cut the particular image carefully off the sheet.
2. Soak it in lukewarm water for 10 seconds.
3. Put the wet image on some non-blotting surface.
4. Place the image still on the base paper to the model. Hold the image with tweezers and remove the paper carefully. If the image is placed incorrectly, add some water to the image border using a brush. The image position can then be corrected.
5. If the image is placed correctly, press it with soft cloth to eliminate excess water and air bubbles.
6. Allow the decal to dry well.
7. We recommend to coat the model surface with your favourite varnish to achieve a uniform finish. It also helps to keep the decals in place.



© AML 2003  
 LAZAR Miroslav  
 Ke Studánce 1048  
 735 14 Orlová-Lutyně  
 The Czech Republic  
 www.aml.cz  
 E-mail: aml@aml.cz  
 Fax: ++420 599509420