

Seafire F.Mk.III was the first version of the Seafire to specifically meet all the requirements for a carrier-based fighter. The first Mk.III's flew in November 1943 with 894 Sqn.FAA at RNAS Henstridge. The F. Mk. III was powered by Merlin 55 with four bladed propeller, equipped six-stack multiple exhausts and narrow blister fairings over 20mm cannons in wings, the Seafire III was fitted with a manual folding wing, which allowed below deck stowage. However folding wing caused a lot of problems, especially during service in Pacific campaign.

The F. Mk. III was quickly replaced by the F. Mk. I III, which used the Merlin 55M engine to give maximum performance in low altitudes below 5,000 feet. Some 1,250 Seafire IIIs were manufactured - Westland built 900 and Cunliffe-Owen produced 350.

The Seafire III first entered combat in April 1944 as fighter escorts for the raids on the "Tirpitz" in Norway.

The top-scoring Seafire pilot of the war was Sub□Lieutenant R.H. Reynolds, DSC, of 894 Squadron, who claimed 4.5 air victories in 1944-5. During the campaign in the Pacific, 887 Squadron claimed 12 victories, while 894 Squadron claimed 10 victories, with two more victories claimed earlier in 1944 over Norway. HMS Indefatigable contributed one□third of the Fleet Air Arm sorties flown in the Pacific.

Seafire III was one of the finest ship-board fighters, although Seafire Ib was considered by many members of flying personnel as better.

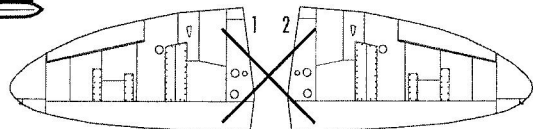

URETHAN

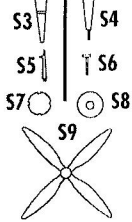
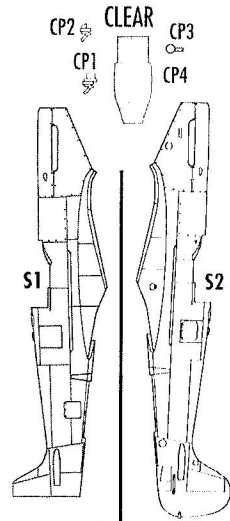
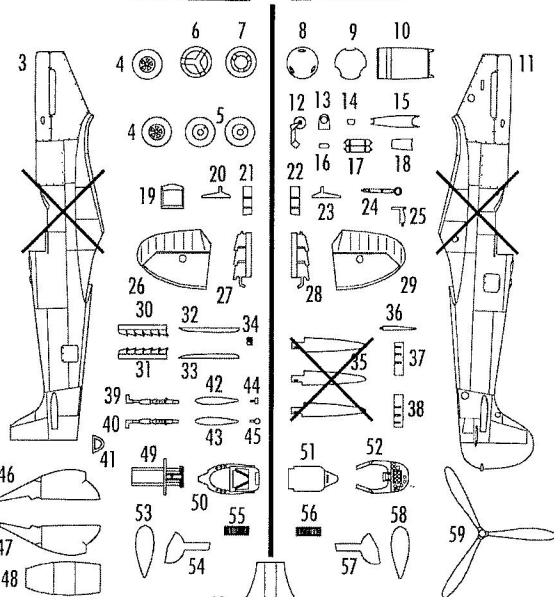
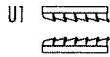

- A Černá/Black
- B Interierová zelená
Interior Green
- C Stříbrná/Silver
- D Hliník/Aluminium
- E Světle šedá/
Light Grey
- F Červená/Red
- G Žlutá/Yellow
- H Zelená/Green
- I Černošedá/
Tyre Black
- J Špinavý hliník/
Dirty Aluminium
- K Chromová/
Chrome
- L Hnědá/Brown
- M Kovová/Gun metal
- N Dřevo/Wood
- O Rezavá/Rust

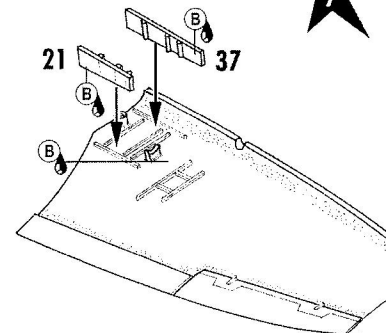
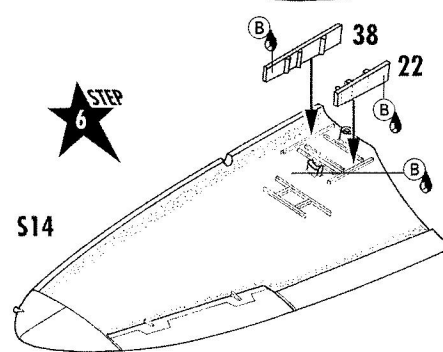
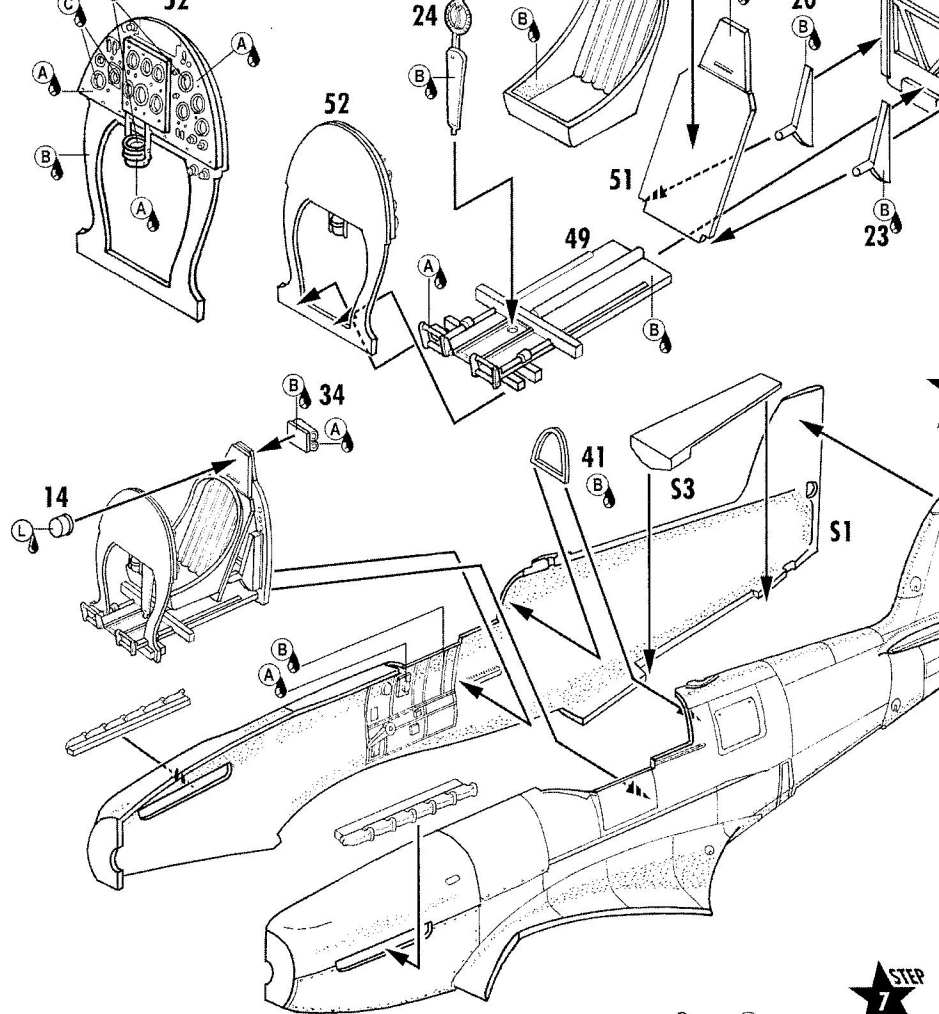
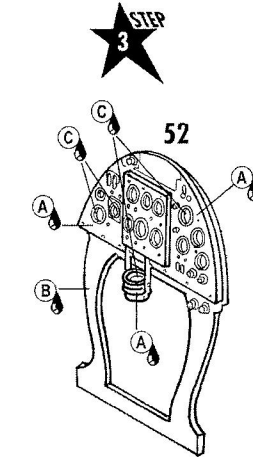
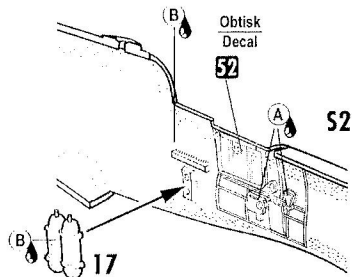
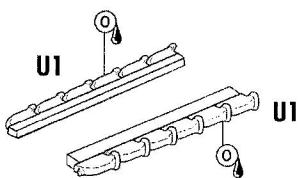
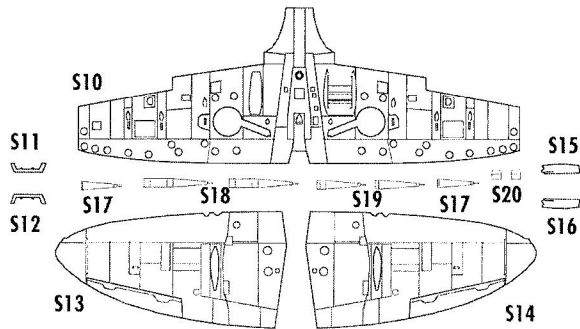

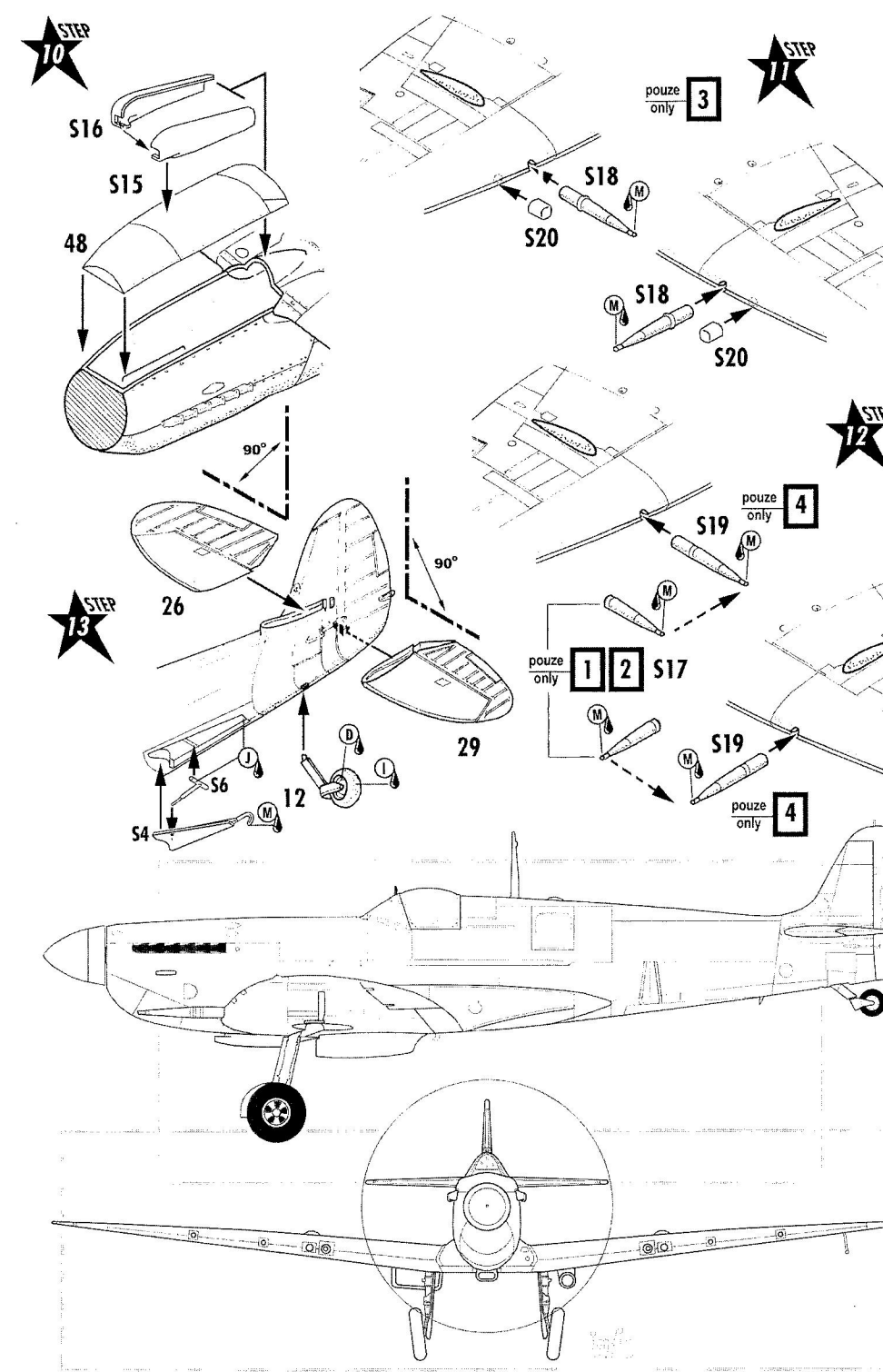
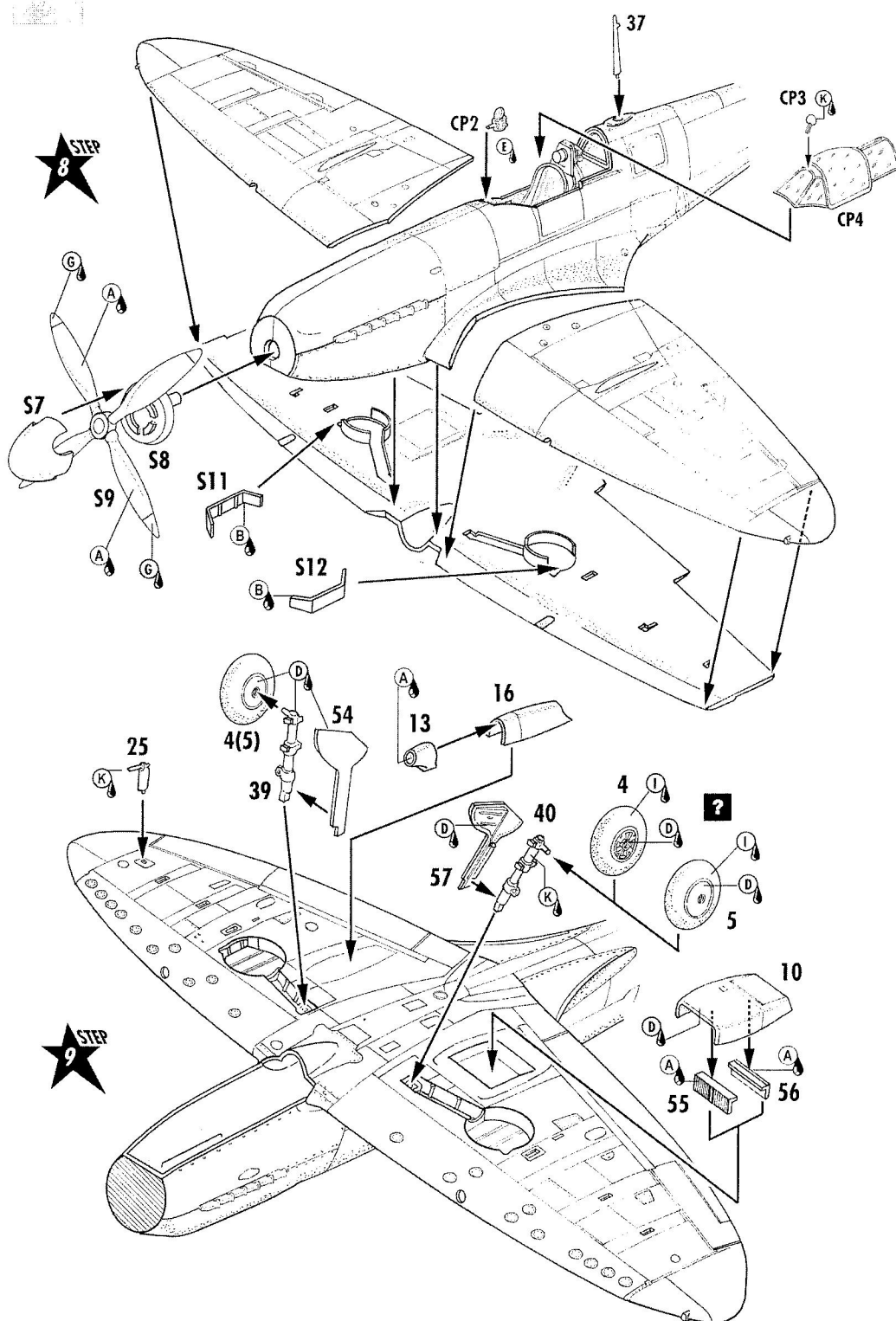

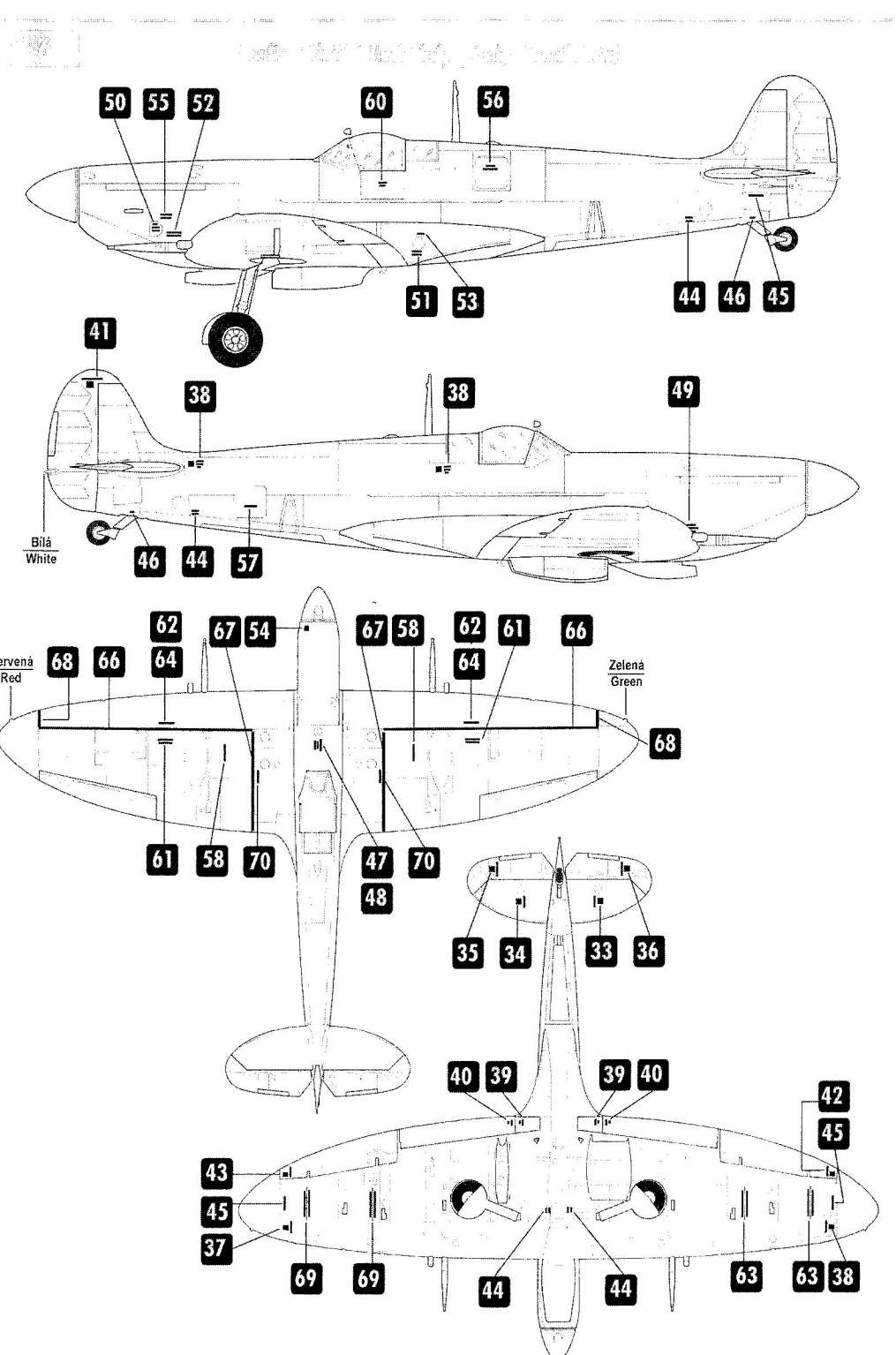

Supermarine Spitfire Mk.III, of No 894 NAS, HMS Indefatigable, British Pacific Fleet, Salishima Gunto group of islands, May 1945
 flown by Sub/Lt Richard Reynolds, RNVR

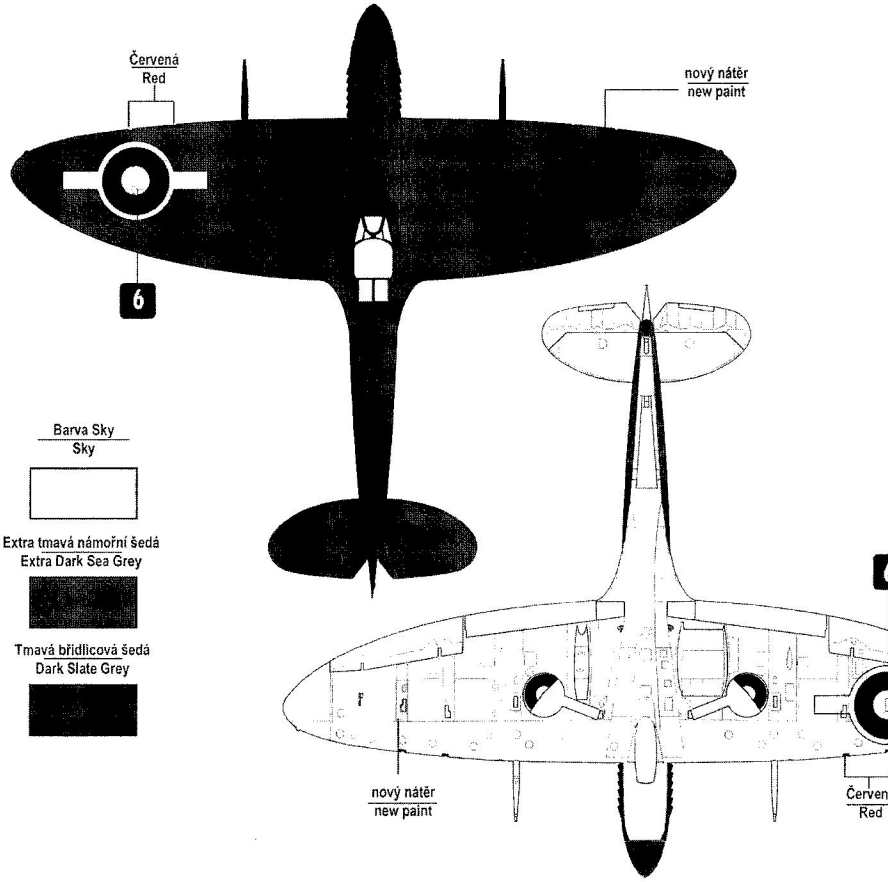
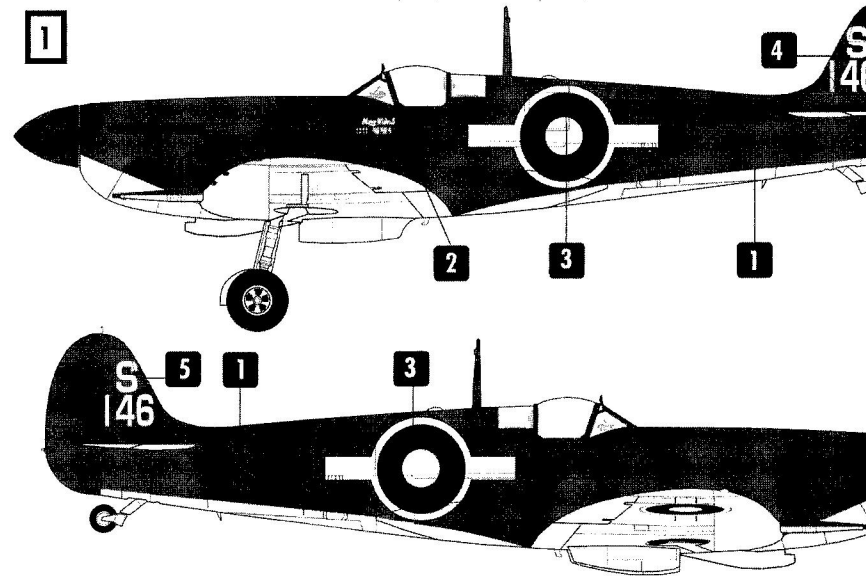

Seafire Mk III, of No 807 NAS, HMS Hunter, British East Indies Fleet, Andaman Sea, May 1945

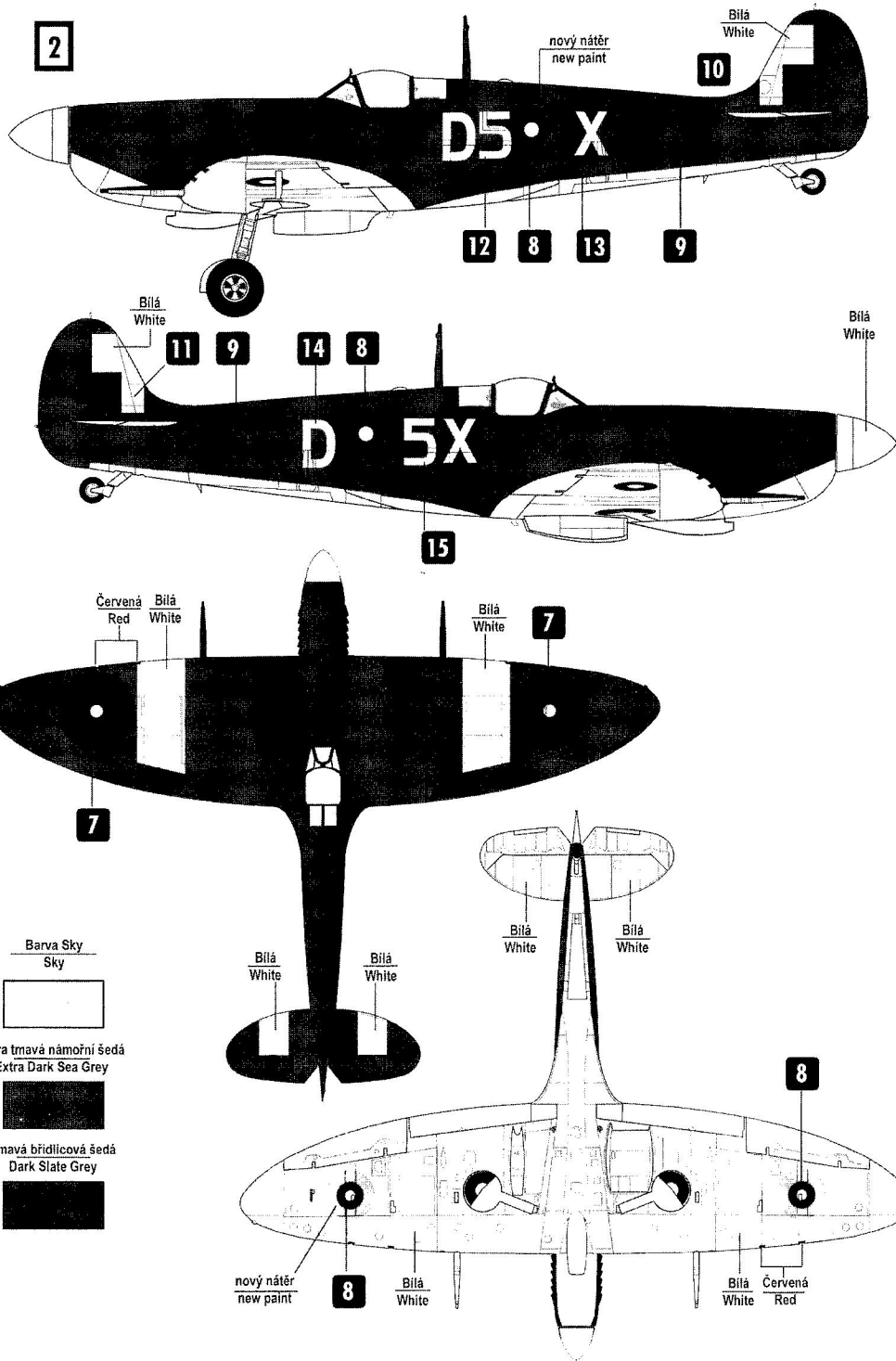

- Barva Sky
Sky
- Extra tmavá námořní šedá
Extra Dark Sea Grey
- Tmavá břidlicová šedá
Dark Slate Grey

Seafire Mk III, of No 807 NAS, HMS Implacible, October 1944 or No 761 NAS, HMS Ravenor, May 1945

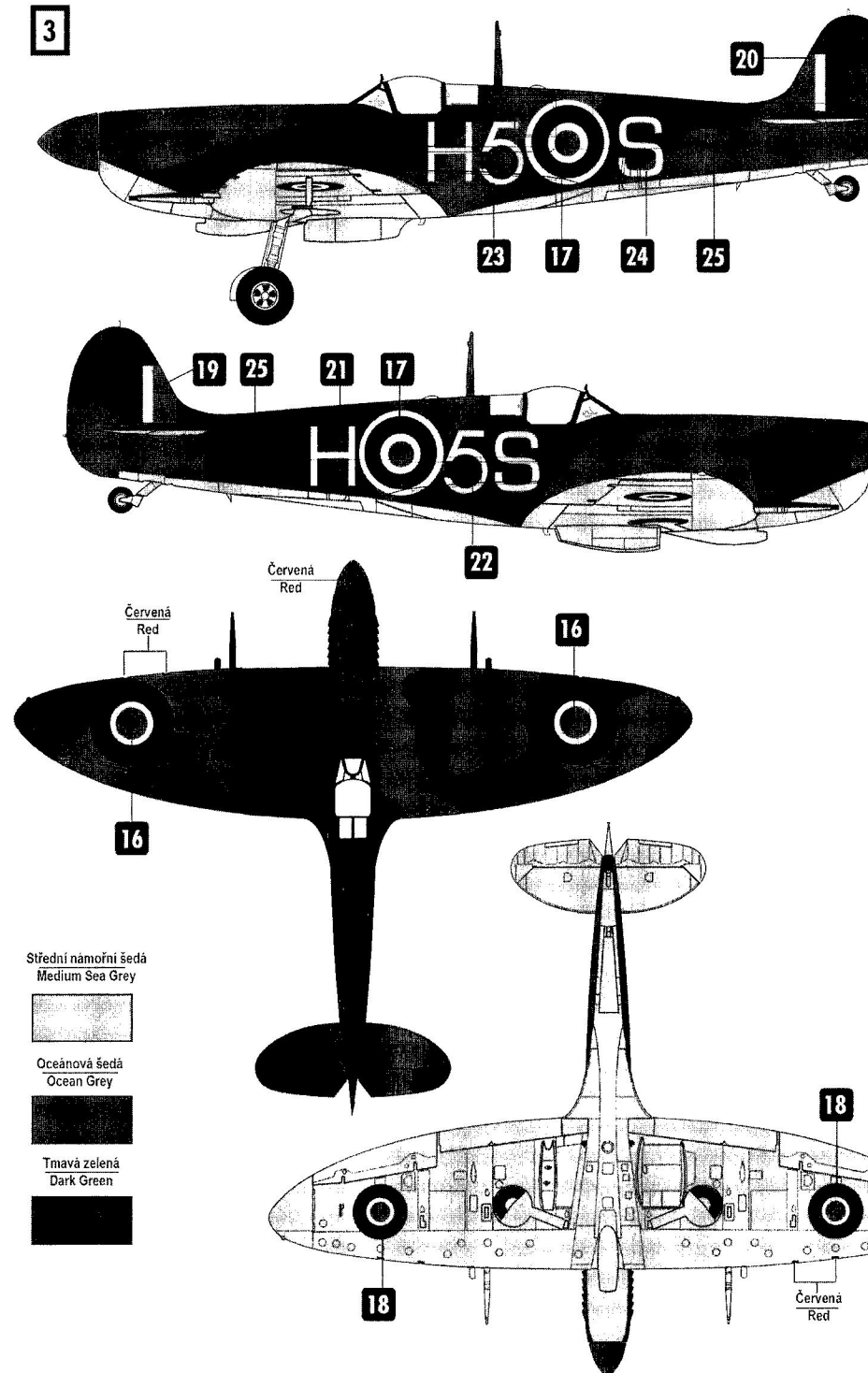

- Střední námořní šedá
Medium Sea Grey
- Oceánová šedá
Ocean Grey
- Tmavá zelená
Dark Green

Seafire Mk.III, of flotilla I.F., aboard Anomanches, in Gulf of Tonkin, December 1940

4

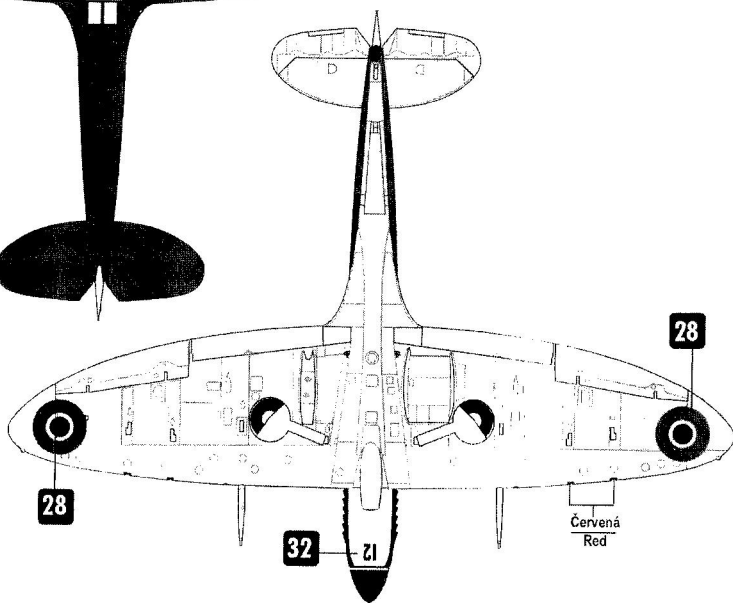
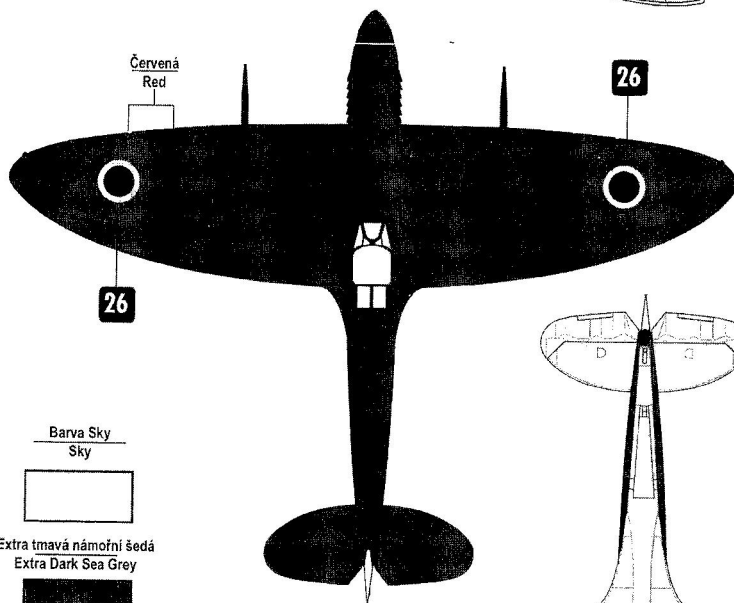
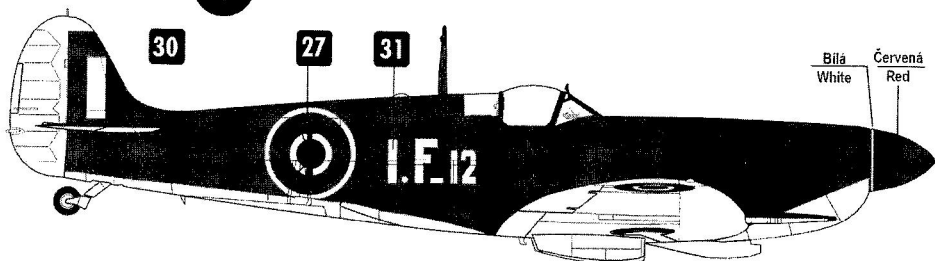
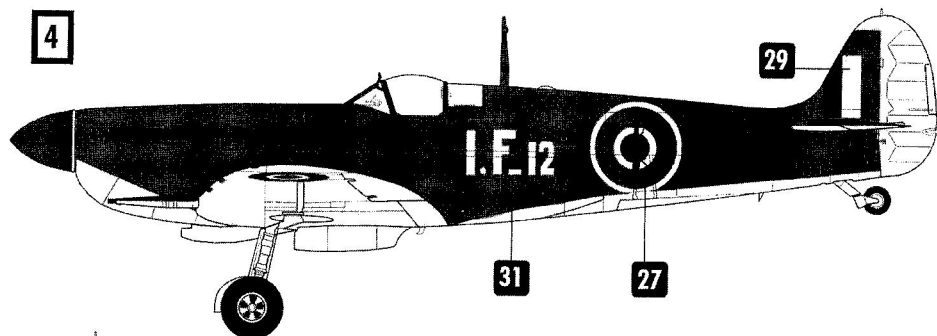

Barva Sky
Sky



Extra tmavá námořní šedá
Extra Dark Sea Grey



Tmavá břidlicová šedá
Dark Slate Grey

