

M3 LEE Mk I

1/35 MILITARY MINIATURE SERIES

TAMIYA
TAMIYA PLASTIC MODEL CO.
3-7 ONDAWARA, SHIZUOKA-CITY, JAPAN.



Background of Development

Under impetus from the activity of German tank divisions at the initial stage of World War II, Major General Adna R. Chaffee, Chief of the Armoured Force, met Major General Charles M. Wilson, Chief of Ordnance of the Department of the Army, on 28th August, 1940 in a conference room of Aberdeen Proving Ground, Maryland, for a conference on a development plan for main-strength tanks to be used by the newly organized armoured army consisting of one armoured corps, two armoured divisions and one separate tank battalion under the direct control of the army and also by existing armoured divisions which were to be reinforced and sent to the European theatre of the war.

The U.S. Army planned to supply the armoured forces organized on 15th July, 1940

M2A1

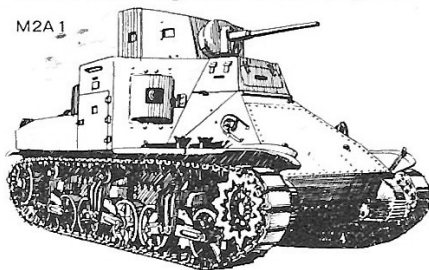

with the M2A4 light tank carrying a 37 mm tank gun M5 (53.5 calibre long) which had grown from the T2 pilot light tank series designed and developed by Rock Island Arsenal in Illinois—the only specialized tank factory in the United States of those days—and also with the M2A1 medium tank having a 37 mm tank gun M6 (53.5 calibre long) on the new turret. M2A4 light tanks and M2A1 medium tanks were to be produced

at a ratio of three to one in number. The first order for M2A4s was placed with American Car & Foundry in Berwitz, Pennsylvania. Orders for them also went to Baldwin Locomotive Co. and Pullman-Standard Car Co. An order for M2A1s was given to car-maker Chrysler Corporation. These manufacturers were to produce a total of 9,200 tanks by August 1942. In armament, the M2A4 light tank and the M2A1 medium tank were no match for the PzKpfw III Ausf. E with a 50 mm tank gun, model 39 (42 calibre long)

PzKpfw III



PzKpfw IV

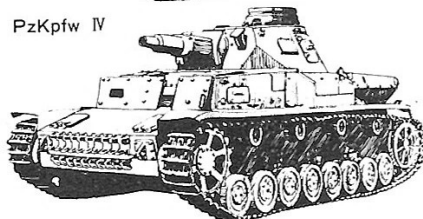

and the PzKpfw IV with a 75 mm short-barrelled tank gun model 37 (24 calibre long) which both formed the main strength of the most powerful German Panzer divisions. It was therefore concluded that the U.S. armoured forces needed a new medium tank able to attack the German tanks from out of their range. According to the requirements

outlined, the new medium tank was to have weight (equipped) of about 30 tons, armour thickness of 39 mm—75 mm, muzzle velocity of 600 metres per second and effective range of about 3,000 metres.

The new medium tank was to be designed and trial-manufactured by Chrysler under the leadership of Rock Island Arsenal, but tank engineers knew from experience that it was impossible to complete in a short period the medium tank required by the commanders of the U.S. armoured forces. Therefore, another tank was made instead on the basis of the T5E2 pilot medium tank having on the frontal right sponson a 75 mm pack howitzer M1 (15.93 calibre long) which the 7th Separate Cavalry Brigade (mechanized) had been requiring and trial-manufacturing for their fire support since 1938 and in the light of the French B1 heavy tank equipped with a 75 mm tank gun, the body being designed by Watervliet Arsenal and the cast revolving turret for the 37 mm tank gun by Aberdeen Proving Ground.

Chrysler Corporation which had received a contract for the M2A1 medium tank was now ordered to produce the new tank. After carefully studying the Ordnance Department's requirements in a Detroit Arsenal office on a high street of Detroit, Michigan, Chrysler engineers started preparing for the production of the new medium tank in August 1940. They started in January 1941 to trial-manufacture two new medium tanks which needed about 6,000 drawings and consisted of about 26,000 main parts and completed them on 11th April of that year. These prototypes were entirely different in shape from existing standard tanks.

The prototypes had three turrets. A sponson on the right side of the hull was for the 75 mm tank gun, a cast revolving turret on the central left of the hull was for the 37 mm tank gun and a revolving machine gun turret at the top of the cast revolving turret was for the calibre 0.30 (7.62 mm) Browning machine gun. Furthermore, the prototypes carried four additional calibre 0.30 (7.62 mm) Browning machine guns. After being put to practical tests at Aberdeen Proving Ground and Fort Knox, the prototypes equipped with such strong armament were designated M3 medium tank. Putting confidence in the M3, officers and men of the armoured forces called it "Moving Fortress" after the example of the great Boeing B17 super-heavy bomber "Flying Fortress".

Production Setup

The M3 medium tank was also called "General Lee" after Robert Edward Lee, resourceful general. —Robert Edward Lee was commander in chief of the Confederate army in the Civil War who obtained renown by pertinent command. Although he lost the war, he became president of Washington College and established his fame also as an educator. He has been idolized by people in the Southern States. —In August 1941, the first production plan for 2,200 M3 medium tanks was put into action by Chrysler Detroit Arsenal.

Because the ratio of production between light tanks and medium tanks was changed at such time to one to one owing to the change in the number of tanks to be supplied to armoured units, American Locomotive Co. and Baldwin Locomotive Co. were ordered to take part in the production of medium tanks. According to the plan, Detroit Arsenal was to produce 1,000, American Locomotive 685, and Baldwin Locomotive 535. In reality, Detroit Arsenal produced 3,243. American Locomotive and Baldwin Locomotive, which did not have satisfactory production facilities, manufactured only 385 and 295 respectively. For the British Army, Pressed Steel Car made

501 and Pullman-Standard Car made 500. Thus the production of the Lee Mk I totalled 4,924 by August 1942.

Use by Fighting Units

In October 1941, the Lee Mk I was supplied for the first time to the 69th Armoured Regiment of the 1st Armoured Division, the 67th Armoured Regiment of the 2nd Armoured Division and the 70th Separate Tank Battalion. At the Second Battle of El Alamein in October 1942, the British 8th Army used 250 Lee, Mk I s. In the Pacific theatre of the war, the 193rd Tank Battalion of the U.S. 8th Army first used the medium tank at about the same time for the counter-offensive operations against the Japanese in the Solomon Islands.

In December 1942, a U.S. division equipped with the Lee Mk I made a full-scale tank-to-tank fighting in Tebourba, Tunisia. The 2nd Battalion, 13th Armoured Regiment, Armoured Combat Group B, 1st Armoured Division under the command of Brigadier General Paul A. Robinett made a two-week fighting with the German 10th Tank Division supported by the 501st Tiger Heavy Tank Detachment and lost 54 out of its 60 Lee Mk I s. By inflicting serious damage also on the German tanks of the 10th Tank Division and checking the advance of the enemy, however, the Lee Mk I s turned the tide of subsequent operations in favour of the Americans and prepared the ground for their victory in the Battle of Tunisia.

M3A2

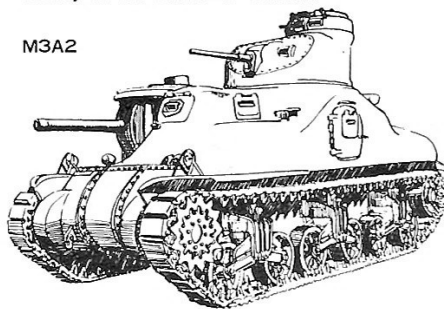

M4

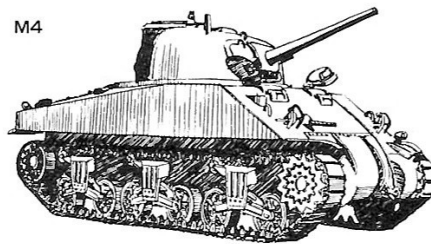

The M3 medium tank General Lee series consisted of six types as in the following: M3 (Lee Mk I), M3A1 (Lee Mk II), M3A2 (Lee Mk III), M3A3 (Lee Mk IV), M3A4 (Lee Mk V) and M3A5 (Lee Mk VI). The General Lee series with total production of 6,248 formed the main strength of the armoured forces until the M4 medium tank General Sherman series was delivered to them.

In April 1943, the General Lee was reclassified from "standard" to "limited standard" and, in April 1944, was declared obsolete and struck off the equipment list. The General Lee completed production in a short period of only about eight months, which was without precedent in the development history of main-strength tanks.

Main Specification of the M3 Lee Mk I

Overall length : 5.639 m
 Overall width : 2.718 m
 Overall height : 3.124 m
 Weight (equipped) : 28.250 t
 (empty) : 27.216 t
 Armament: One 75 mm tank gun M2 (31calibre)
 One 37 mm tank gun M5 (53.5 calibre)
 Five Browning M1919A4 machine guns
 Engine : Continental R-975-C1 radial air-cooled (gasoline)
 Max. hp : 350 hps/2,400 rpm
 Max. speed : 41.6 km/h
 Max. grade ability : 60 % (31°)
 Cruising range : 192 km
 Ammunition, stowage 75 mm: 46 rounds
 37 mm: 178 rounds
 7.62 mm MG: 9,200 rounds
 Crew : Six



PAINTING



APPLYING DECALS

The standard painting of a U.S. tank is a single olive drab colour. In case of a new tank just out of factory line, the whole vehicle except for a machine gun and a pair of tracks is sprayed in this colour.

★ In order to increase the reality of a model, a so-called "weathering" will be effective. It includes a dirty surface smeared with grime, and gleaming teeth of a sprocket wheel due to wear. Choose one scheme according to the condition under which your model is supposed to be used.

⟨Paint to be used⟩

- Flat Black
- Flat Red
- Metallic Grey
- Olive Drab
- Dark Green
- Flesh

⟨Markings on M3 Lee Tank⟩

Apply markings as shown in the right plans. ⟨Marks of Vehicles of 1st Armoured Division⟩ These were worn by vehicles of the 1st Armoured Division which saw action early in the Battle of Tunisia on the North African theatre in and after November 1942.



Nationality identification mark used since the second half of 1942.



This mark represents the 3rd vehicle of the F Company, 2nd Battalion, 13th Armoured Regiment, 1st Armoured Division.

Kentucky

This shows that the commander of the vehicle was a Kentuckian.

U.S.A W-309513

"W" stands for weapon. "30" means tank and "9513" is a registered number. "W" was disused in 1942.

⟨Marks of Vehicles in 2nd Armoured Division⟩ These were worn by M3 Lee tanks of the 2nd Armoured Division "Hell on Wheels" dispatched on 8th November 1942 to support the 3rd and 9th Infantry Divisions advancing in North Africa.



Nationality identification mark for combat vehicles produced in 1941-1942.

D-10

This represents the 10th vehicle of the D Company, 2nd Battalion, 67th Armoured Regiment.

No.3 tank of 'F' Company of 2nd Battalion of 13th Armoured Regiment of 1st Armoured Division, 1942.

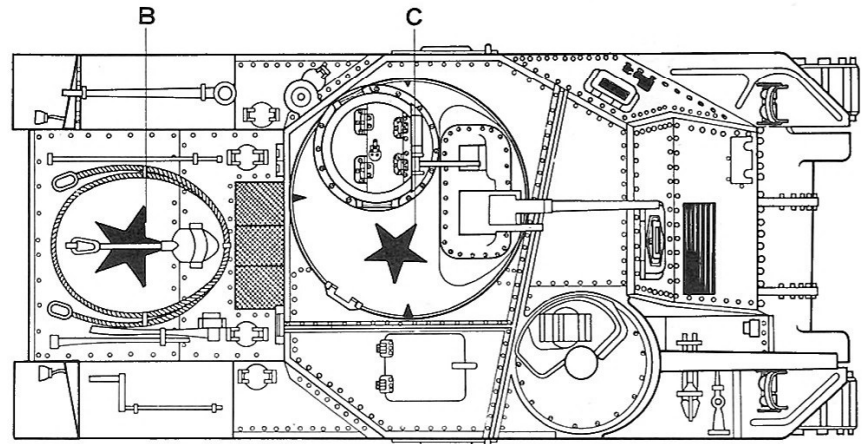
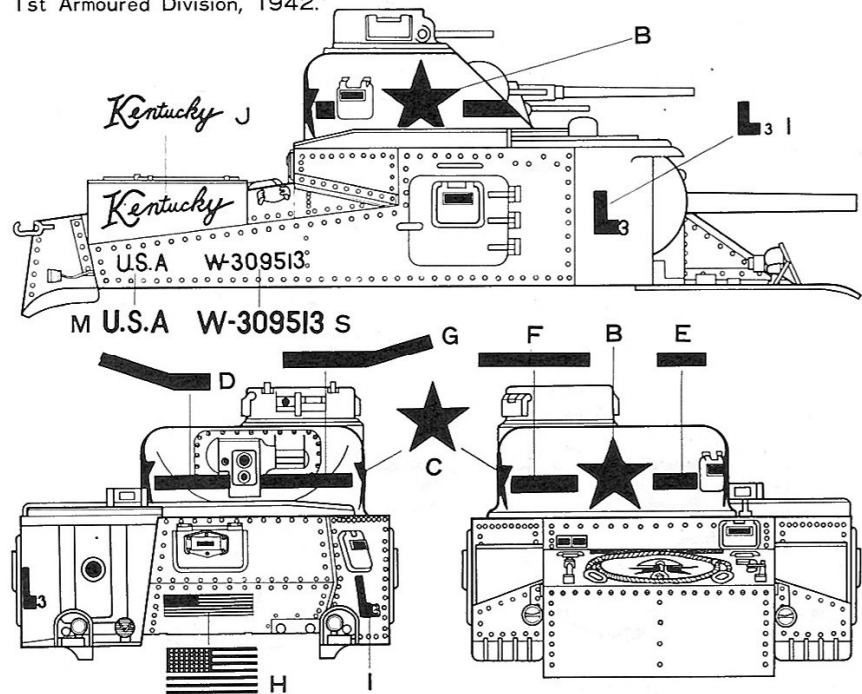

No.10 tank of 'D' Company of 2nd Battalion of 67th Armoured Regiment of 2nd Armoured Division, 1942.

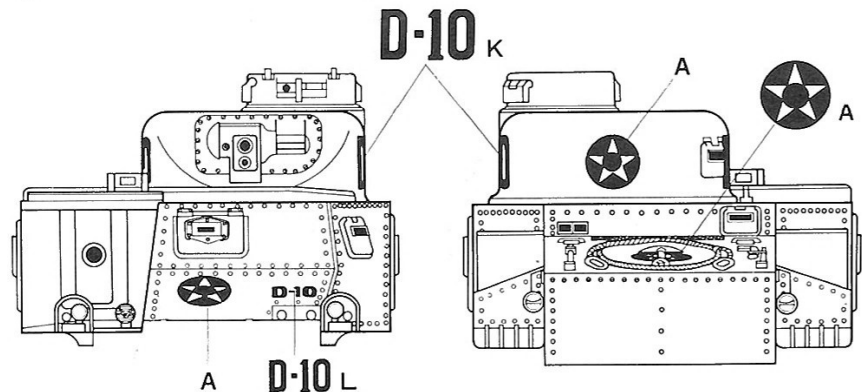
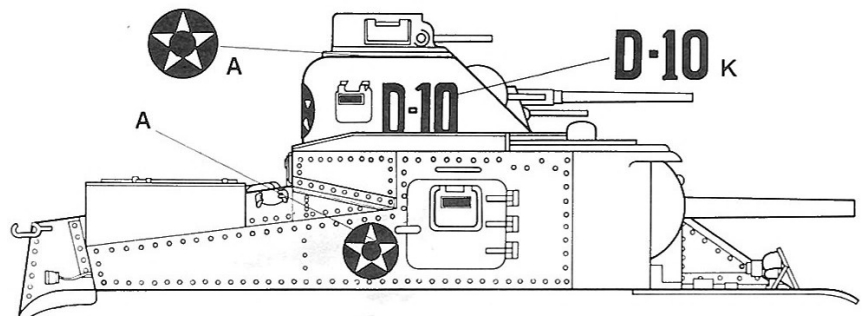



**READ BEFORE
ASSEMBLY.**
**ERST LESEN
— DANN BAUEN.**

★Study the instructions and photographs before commencing assembly.
★You will need a sharp knife, a screwdriver, a pair of tweezers, a file, and a pair of pliers.

★Before finally cementing each part together, be sure that parts fit correctly together. And that you are of the next sequence to be followed.

★You will probably find it easier to paint smaller parts whilst they are still on the runner.

★Painting Your Model

As well as adding the reality of your completed model, painting will give you a pleasure to make your own model. Moreover, paint coat ensures a good application of decals.

☛ This mark shows recommended colour scheme.

1 (Construction of Wheels)

★Construct six Suspensions. C1 and C7 will rotate and should be held down with C9 and C10.

★Construct two Drive Sprockets and two Idler Wheels. C4 and C5 are moveable and must not be glued.

2 (Construction of Rear Panel)

★Right and Left Exhaust Pipes A26 & A27 look alike. Make sure of their numbers before assembly. Part B23 is moveable. Just push in parts B34.

3 (Construction of 75 mm Gun)

★Lights B17 & B18 look alike. Make sure of their numbers.

4 (Construction of 75 mm Gun)

★B24 holds down B32. Firmly fix B24 to B32 so that B24 does not come off when B32 moves.

4 (Construction of Front Part)

★B23 is moveable and should be fit in B37.

5 (Construction of Lower Hull)

Insert Rear Panel from above with Lower Hull stretched to right and left a little.
★The same Suspensions, Drive Sprocket and Idler Wheel should be fixed to both sides. Drive Sprockets and Idler Wheel will rotate and should be glued to pins projected from Lower Hull by applying adhesive only to their ends. Never put adhesive on the wheels.

1 Construction of Wheels

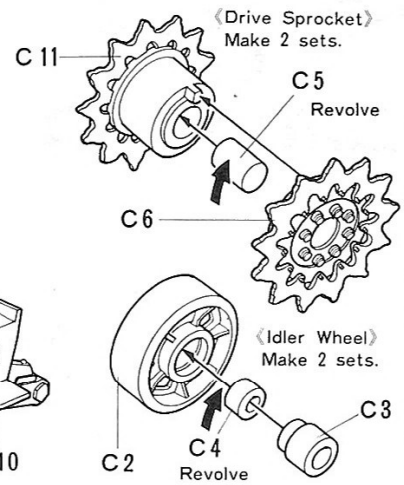
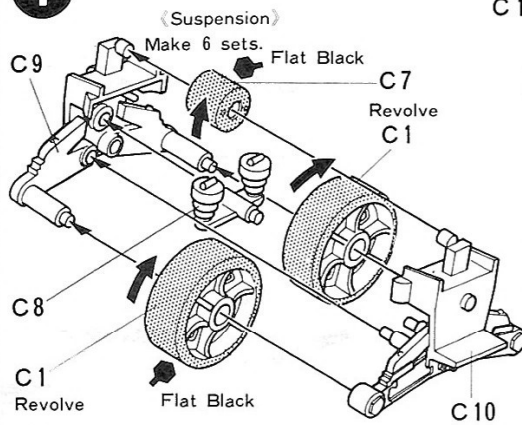

2 Construction of Rear Panel

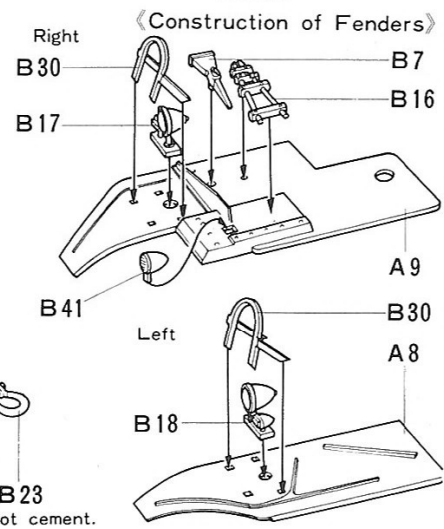
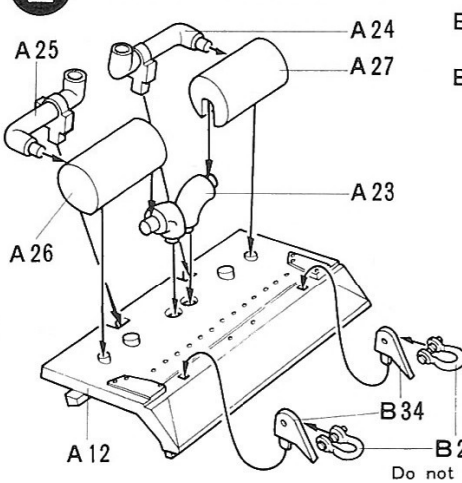

3 Construction of 75 mm Gun

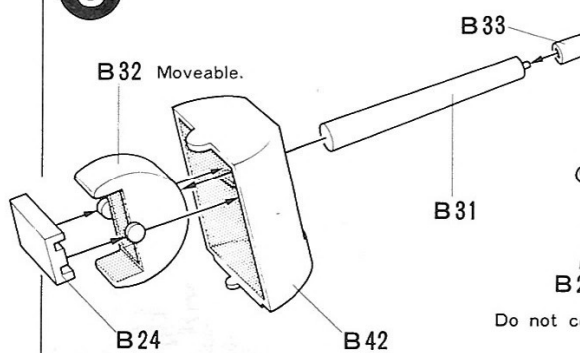

4 Construction of Front Part

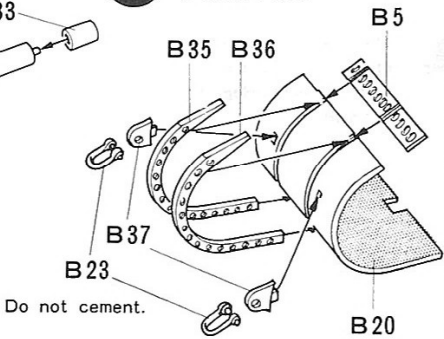

5 Construction of Lower Hull

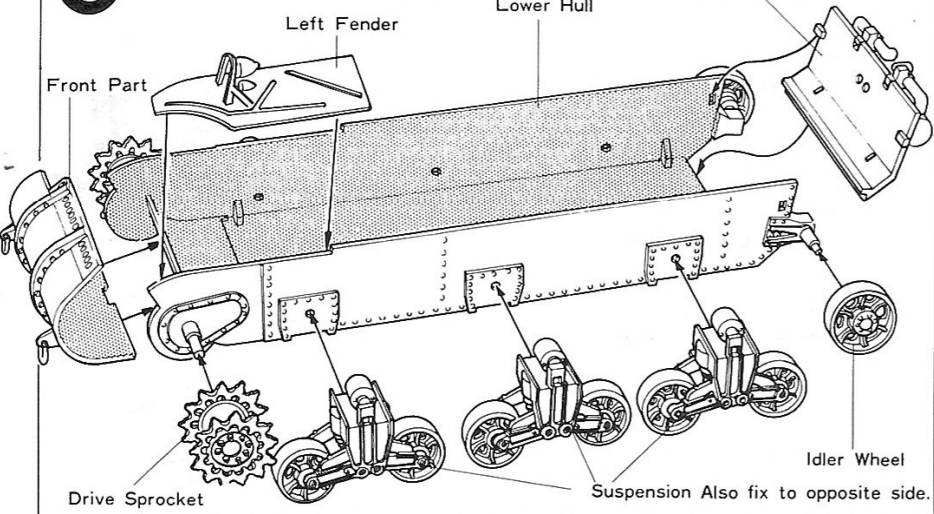

⑥ Fixing Upper Hull Parts (1)

★ Before fixing Upper Hull Parts, be sure to check their numbers.

★ Main Gun should be held down with B19 and Right Fender.

Cement right fender after fixing Main Gun and part B19.

⑦ Fixing Rear Parts

Each should be fixed symmetrically. Make sure of their numbers and assemble.

Construction & Painting of Figure

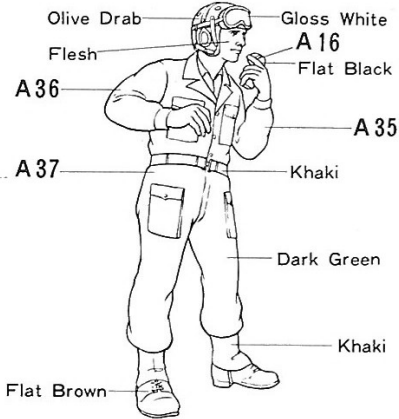

⑧ Fixing Upper Hull Parts (2)

★ Glue Left Fender along the guide line so that it fits Lower Hull well.

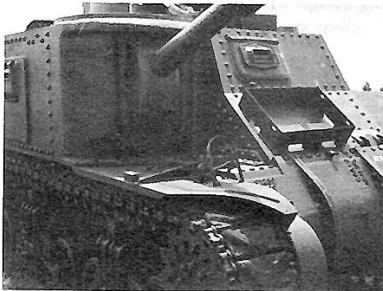

How to make Tracks

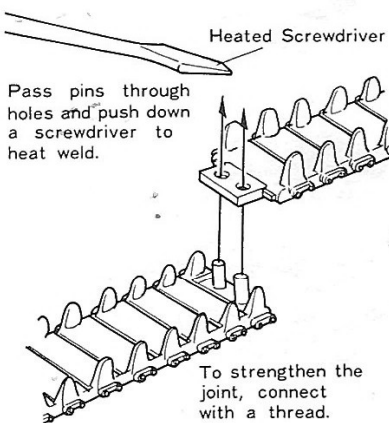

6 Fixing Upper Hull Parts (1)

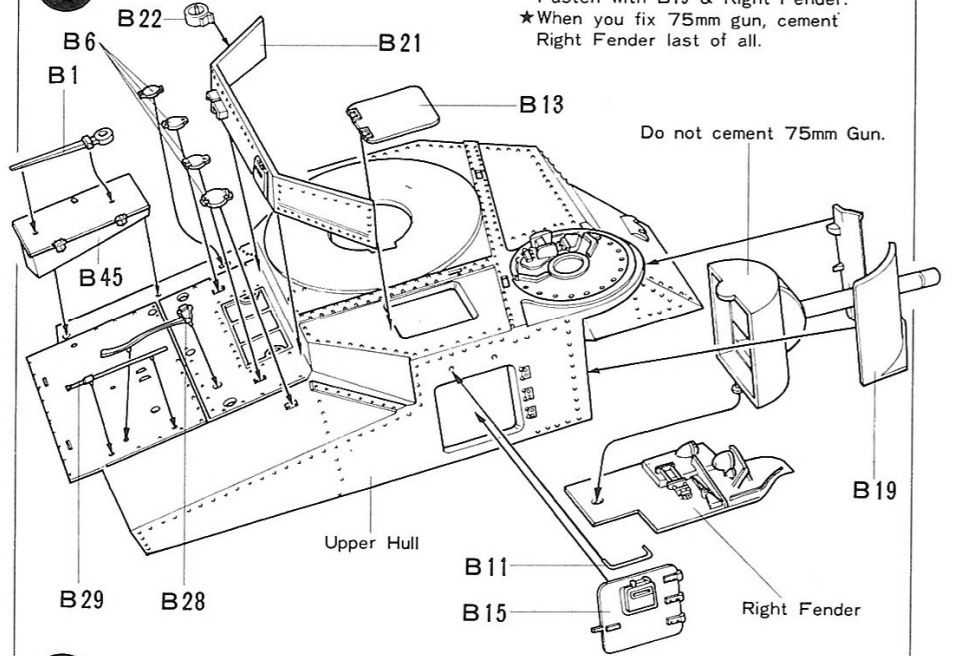

7 Fixing Rear Parts

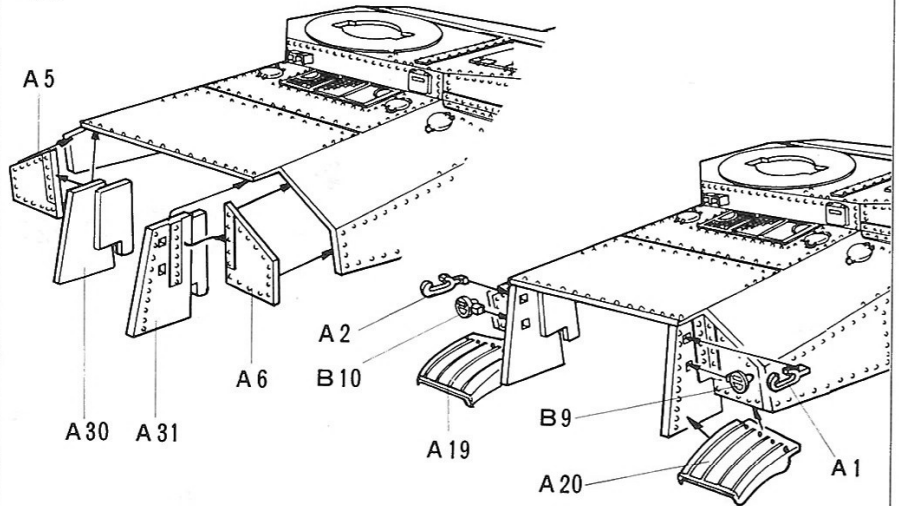

8 Fixing Upper Hull Parts (2)

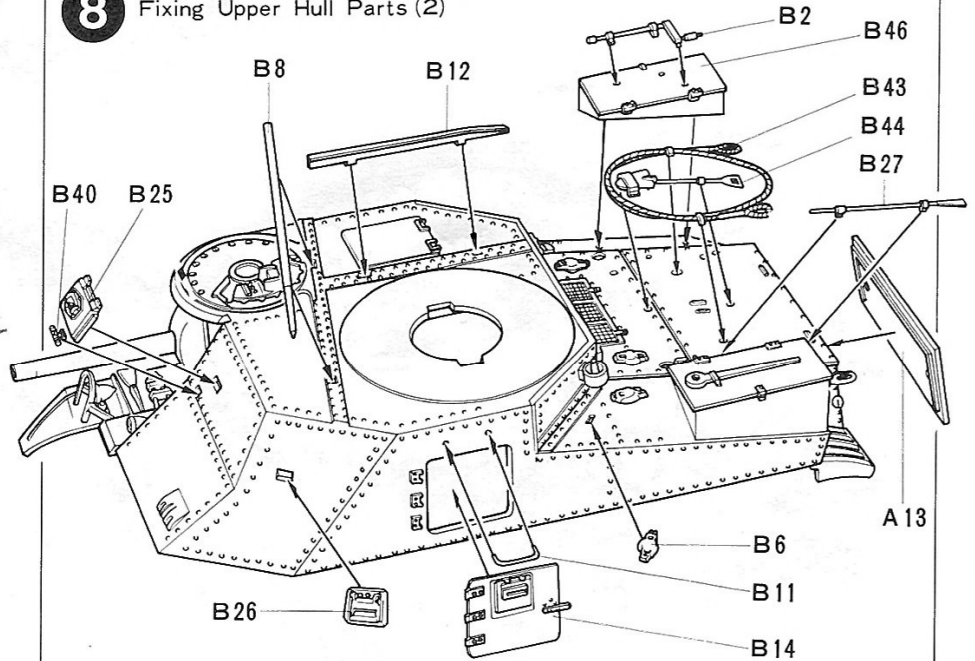

10 (Construction of Turret)

★Fix A7 to the square scribed on Turret A28. Cupola is moveable and should be just put in A28.

11 (Completion of M3 Lee)

Fit Tracks to Lower Hull. Cement Upper Hull and Lower Hull together. Lastly, fix Turret in place. For Markings, see overleaf. Markings should be applied after painting has been completed.

«How to make Antenna»
«Antennenbau»

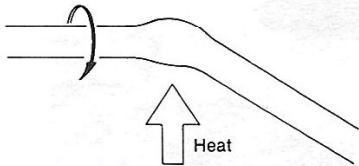

Heat a length of sprue. When melted a little, stop heating and pull to stretch it. Hold for about 15 seconds to cool and cut to proper length.

Ein Stück vom Spritzling über Kerze gerade biegen. Dann in der Mitte im Drehen erhitzen. Wenn Plastik schmilzt, nicht weiter erhitzen und langsam auseinanderziehen.

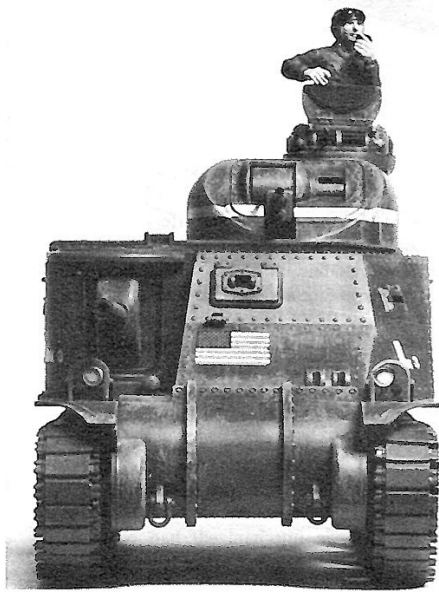

Parts B3 and B4 are unnecessary.

Tamiya Acrylic Paints

Need precise colour matching? Try the new Tamiya acrylic paints. Engineered by modelers for modeler's use. The final cover for the finest models. Insist on Tamiya for perfect results.



TAMIYA COLOR CATALOGUE

The latest in cars, boats, tanks and ships. Motorized, radio controlled and museum quality models are all shown in full color in Tamiya's latest catalogue. At your nearest hobby supply house.



TAMIYA
TAMIYA PLASTIC MODEL CO.
3-7, ONDAWARA, SHIZUOKA-CITY, JAPAN.

9 Construction of Turret Parts

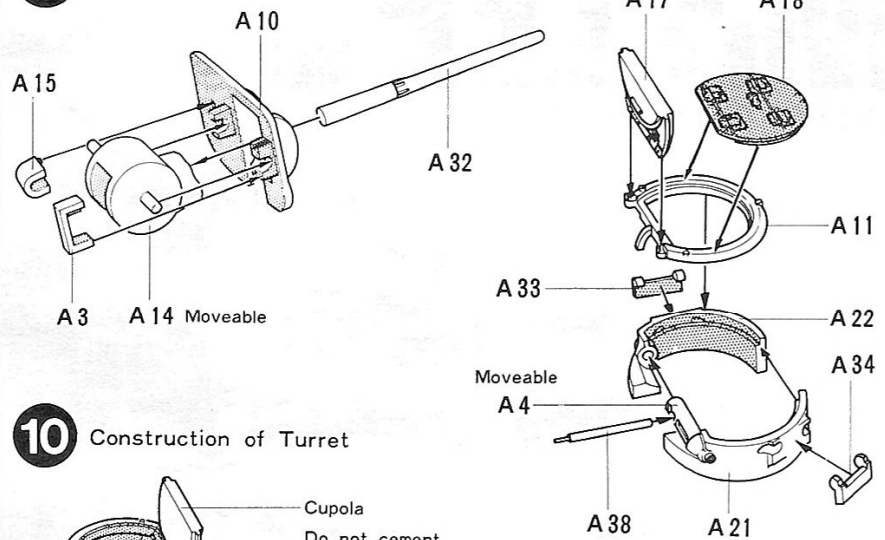

10 Construction of Turret

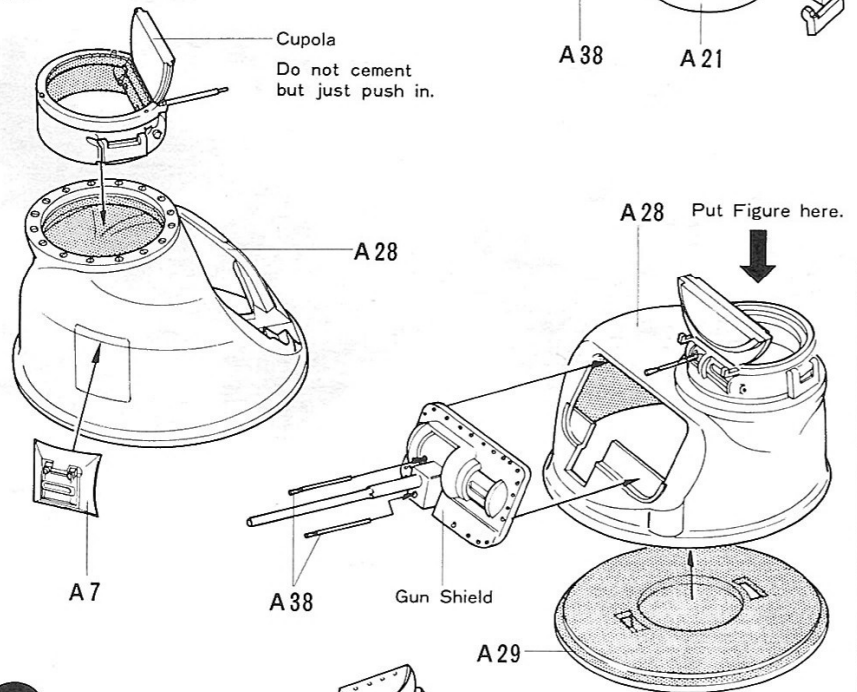

11 Completion of M3 Lee

