

Heller

DORNIER DO 27/CASA C-127

30304



Français

Dornier a construit un avion de liaison monomoteur avec des caractéristiques STOL en Espagne après la Seconde Guerre mondiale. Il a effectué son vol inaugural sous le nom de Dornier Do 25 le 25 juin 1954 à Séville. Le deuxième prototype avait un moteur Continental. Le train d'atterrissage a dû être renforcé pour un moteur plus puissant. De plus, les réservoirs de carburant ont été repensés et la queue verticale a été agrandie. En Allemagne, le premier Do 27 a volé le 17 octobre 1956. Plus de 600 exemplaires ont été fabriqués en Allemagne en 1965. 428 exemplaires ont été construits pour les forces armées allemandes. En Espagne, 50 exemplaires ont été construits par CASA avec licences comprises du Do 27A-1 sous la désignation C-127. De plus, l'Espagne a reçu 26 Do 27 supplémentaires des stocks de la Bundeswehr.

Envergure	12,00 m
Longueur	9,60 m
Hauteur	2,71 m
Autonomie	environ 840 km
Vitesse maximale	248 km/h
Moteur	moteur boxer 6 cylindres Lycoming GO-480B1A6, 270 ch (199 kW)

Deutsch

Dornier baute nach dem 2. Weltkrieg in Spanien ein einmotoriges Verbindungsflugzeug mit STOL-Eigenschaften. Es hatte als Dornier Do 25 am 25. Juni 1954 in Sevilla seinen Erstflug. Der zweite Prototyp hatte einen Continental-Motor. Für ein leistungsstärkeres Triebwerk musste das Fahrwerk verstärkt werden. Weiterhin wurden die Kraftstoffbehälter umkonstruiert und das Seitenleitwerk wurde vergrößert. In Deutschland flog die erste Do 27 am 17. Oktober 1956.

Bis 1965 entstanden in Deutschland mehr als 600 Exemplare. Für die deutschen Streitkräfte wurden 428 Exemplare gebaut. In Spanien entstanden bei CASA 50 Exemplare als Lizenzbauten der Do 27A-1 unter der Bezeichnung C-127. Weiterhin erhielt Spanien aus Beständen der Bundeswehr weitere 26 Do 27.

Spannweite	12,00 m
Länge	9,60 m
Höhe	2,71 m
Reichweite	ca. 840 km
Höchstgeschwindigkeit	248 km/h
Motorisierung	6-Zylinder-Boxermotor Lycoming GO-480 B1A6, 270 PS (199 kW)

Italiano

Dornier costruì in Spagna dopo la Seconda guerra mondiale un aereo di collegamento monomotore con caratteristiche STOL. Il suo primo volo come Dornier Do 25 ebbe luogo a Siviglia il 25 giugno 1954. Il secondo prototipo aveva un motore Continental. Per accogliere un motore più potente, il carrello di atterraggio dovette essere rafforzato. Inoltre, i serbatoi del carburante furono ridisegnati e l'impennaggio verticale venne ampliato. In Germania, il primo Do 27 prese il volo il 17 ottobre 1956. In Germania, fino al 1965 si produssero più di 600 esemplari. Per le forze armate tedesche se ne produssero 428 esemplari. In Spagna, presso CASA si costruirono 50 esemplari come costruzioni su licenza del Do 27A-1 con la denominazione C-127. Inoltre, la Spagna ricevette altri 26 Do 27 provenienti dalle scorte della Bundeswehr.

Apertura alare	12,00 m
Lunghezza	9,60 m
Altezza	2,71 m
Autonomia	circa 840 km
Velocità massima	248 km/h
Motorizzazione	motore boxera 6 cilindri Lycoming GO-480 B1A6, 270 PS (199 kW)

English

Dornier built a single-engine liaison aircraft with STOL characteristics in Spain after the Second World War. It had its maiden flight as the Dornier Do 25 on 25 June 1954 in Seville. The second prototype had a Continental engine. For a more powerful engine, the landing gear had to be reinforced. Furthermore, the fuel tanks were redesigned and the vertical stabiliser was enlarged. The first Do 27 flew in Germany on 17 October 1956.

By 1965, more than 600 aircraft had been built in Germany. 428 were built for the German armed forces. In Spain, 50 Do 27A-1s were built under licence by CASA under the designation C-127. Spain also received a further 26 Do 27s from German armed forces stocks.

Wingspan	12.00 m
Length	9.60 m
Height	2.71 m
Range	approx. 840 km
Top speed	248 km/h
Engine	6-cylinder boxer engine Lycoming GO-480 B1A6, 270 hp (199 kW)

Español

Después de la Segunda Guerra Mundial, Dornier construyó un avión de enlace monomotor de tipo STOL en España. Realizó su vuelo inaugural el 25 de junio de 1954 en Sevilla con la denominación Dornier Do 25. El segundo prototipo contaba con un motor Continental. El tren de aterrizaje se tuvo que reforzar para poder instalar un motor más potente. Además, se rediseñaron los depósitos de combustible y se aumentó el tamaño del estabilizador vertical. En Alemania, el primer Do 27 voló el 17 de octubre de 1956.

Hasta el año 1965 se produjeron más de 600 ejemplares en Alemania. Más de 428 ejemplares fueron producidos para las fuerzas armadas alemanas. En España, CASA construyó 50 ejemplares bajo licencia del Do 27A-1 con la denominación C-127. Además, España recibió otros 26 Do 27 procedentes de las existencias del ejército alemán.

Envergadura	12,00 m
Longitud	9,60 m
Altura	2,71 m
Alcance	aprox. 840 km
Velocidad máxima	248 km/h
Motorización	motor bóxer de 6 cilindros Lycoming GO-480 B1A6, 270 CV (199 kW)

Nederlands

Dornier bouwde na de Tweede Wereldoorlog een eenmotorige verbindingsvliegtuig met STOL-kenmerken in Spanje. Op 25 juni 1954 maakte het toestel zijn eerste vlucht als de Dornier Do 25 in Sevilla. Het tweede prototype beschikte over een Continental-motor. Voor een krachtigere motor moest het chassis versterkt worden. Verder werden de brandstoftanks opnieuw ontworpen en werd de staart vergroot. In Duitsland vloog de eerste Do 27 op 17 oktober 1956.

Tegen 1965 waren er in Duitsland meer dan 600 exemplaren geproduceerd. Er werden 428 exemplaren voor het Duitse leger gebouwd. In Spanje werden 50 exemplaren gebouwd door CASA als licentiehouder van de Do 27A-1 onder de aanduiding C-127. Nog eens 26 Do 27 kwamen van de Bundeswehr.

Spanwijdte	12,00 m
Lengte	9,60 m
Hoogte	2,71 m
Bereik	environ 840 km
Maximumsnelheid	248 km/h
Motor	6-cilinder boxermotor Lycoming GO-480 B1A6, 270 hp (199 kW)



11

Argent métallique
Silver Metallic
Silber metallisch

14

Bleu de france brillant
French Blue Gloss
Französischblau glänzend

18

Orange brillant
Orange Gloss
Orange glänzend

19

Rouge vif brillant
Bright Red Gloss
Hellrot glänzend

27

Gris mer mat
Sea Grey Matt
Seegrau matt

33

Noir mat
Black Matt
Schwarz matt

56

Aluminium métallique
Aluminium Metallic
Aluminium metallisch

62

Cuir mat
Leather Matt
Leder matt

64

Gris clair mat
Light Grey Matt
Hellgrau matt

69

Jaune brillant
Yellow Gloss
Gelb glänzend

99

Jaune citron mat
Lemon Matt
Zitronengelb matt

101

Vert moyen mat
Mid Green Matt
Mittelgrün matt

116

Vert fonce US mat
US Dark Green Matt
US-Dunkelgrün matt

127

Gris fantome US satiné
US Ghost Grey Satin
US-Schattengrau seidenmatt

130

Blanc satiné
White Satin
Weiß seidenmatt

321

Rouge transparent
Red Transparent
Rot transparent

325

Vert transparent
Green Transparent
Grün transparent

M1

85% 18
15% 69

M2

15% 56
85% 127

M3

90% 127
10% 27

2

Numéro de phase
Step number
Schrittnummer
Número de fase

56

Référence de couleur
Colour reference no
Farbangabe
Referencia de color

37

Numéro de pièce
Part number
Teilenummer
Número de pieza

6

Numéro de decal
Decal number
Abziehbildnummer
Número de calcomanía

- Si aucune teinte n'est spécifiée, peindre dans les couleurs de la version choisie. Se reporter aux pages 8 - 10 pour le détail du schéma de peinture.
- When no color is specified, paint the item with colors of chosen version. Refer to pages 8 - 10 for painting pattern.
- Wenn keine Farbe angegeben ist, Teile mit den Farben der gewählten Version bemalen. Beachten Sie die Seiten 8 - 10 für die Lackierung und Markierung.
- Cuando ningún color es especificado, pintarle con los colores del tema de la versión elegida. Vea las páginas 8 - 10 para obtener detalles de pintura.

a Do 27, RK Flugdienst Flugplatz Uetersen. Stützpunkt Appen 2019



b Do 27, Color variant A: Perpignan Rivesaltes. Juni 2012. France
Do 27, Color variant B: Perpignan Rivesaltes. Juni 2020. France

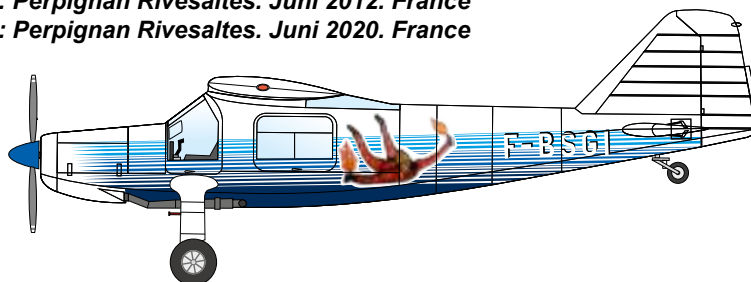

c CASA C-127, Spain Air Force, Military Unit: Ala 23, Spain 1993

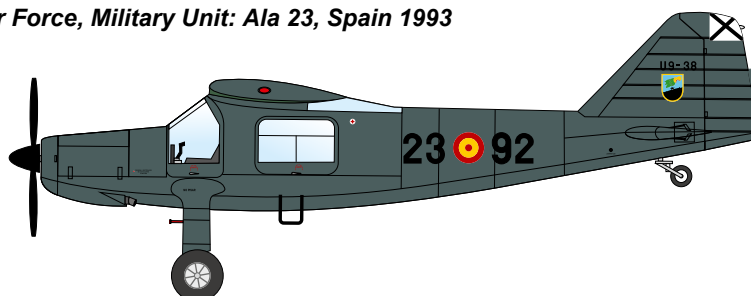

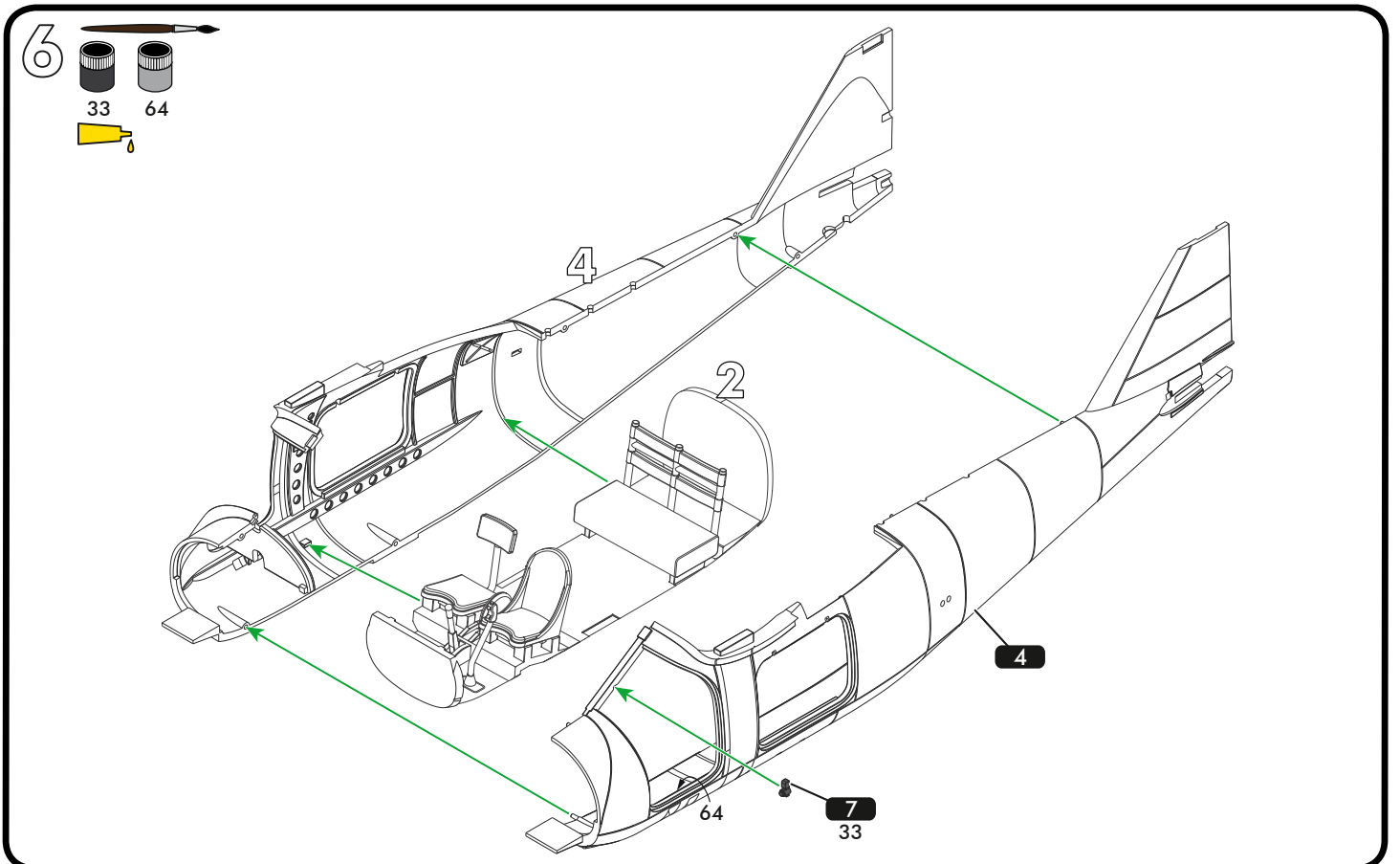
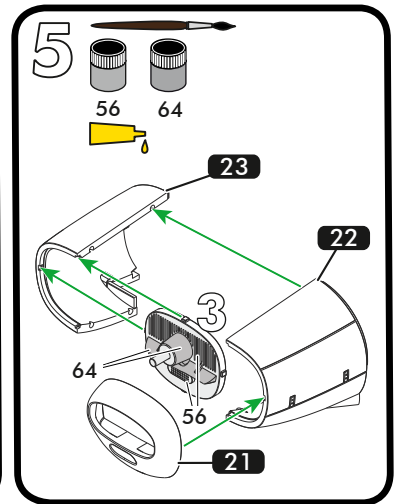
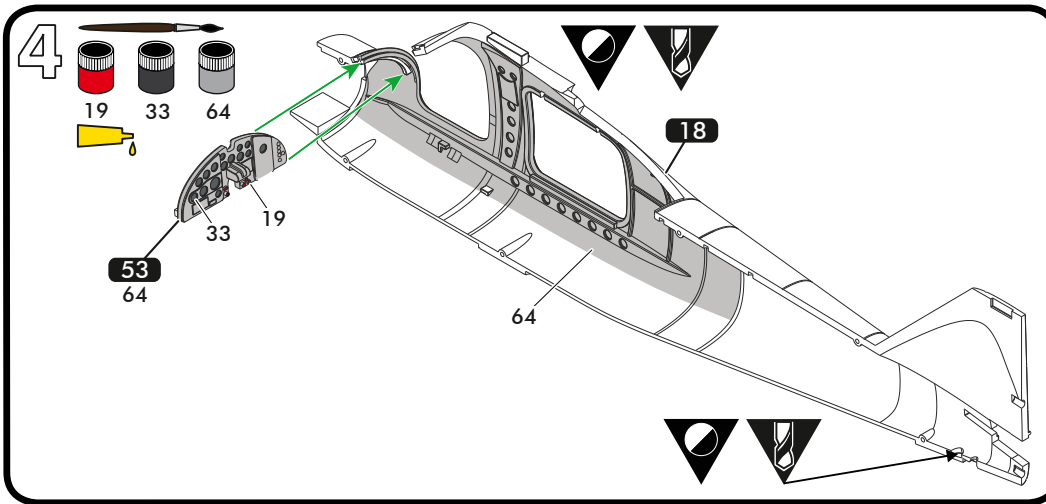
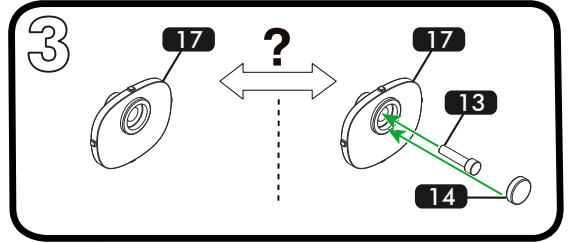
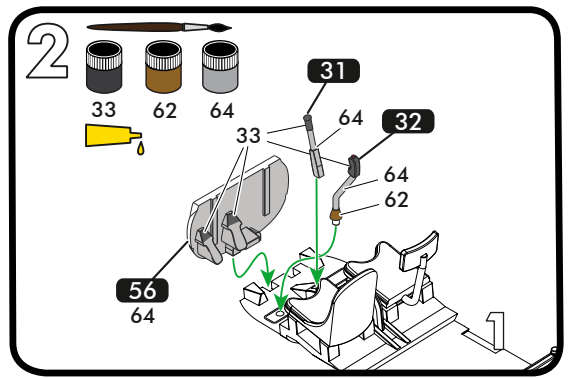
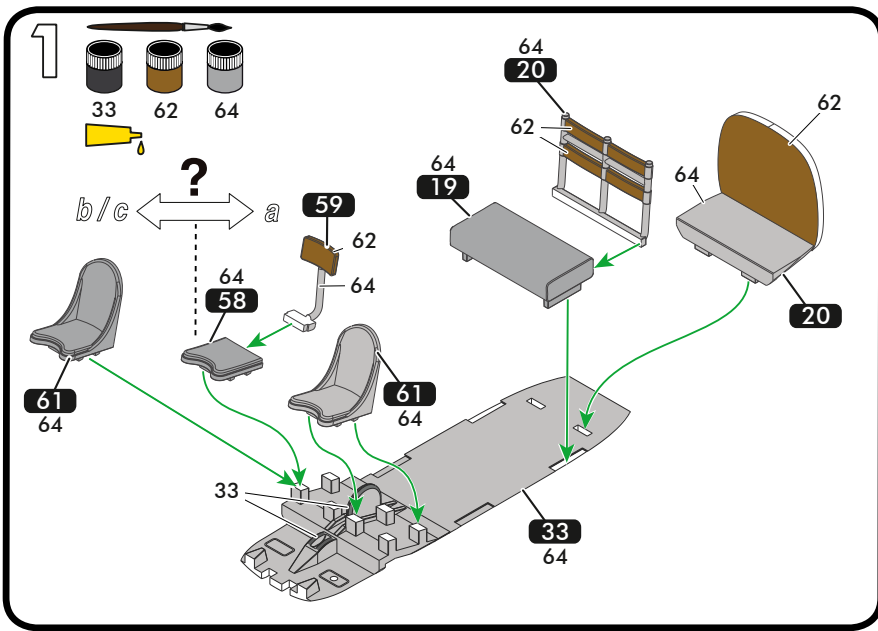

7

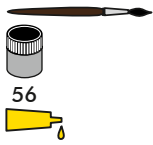

56

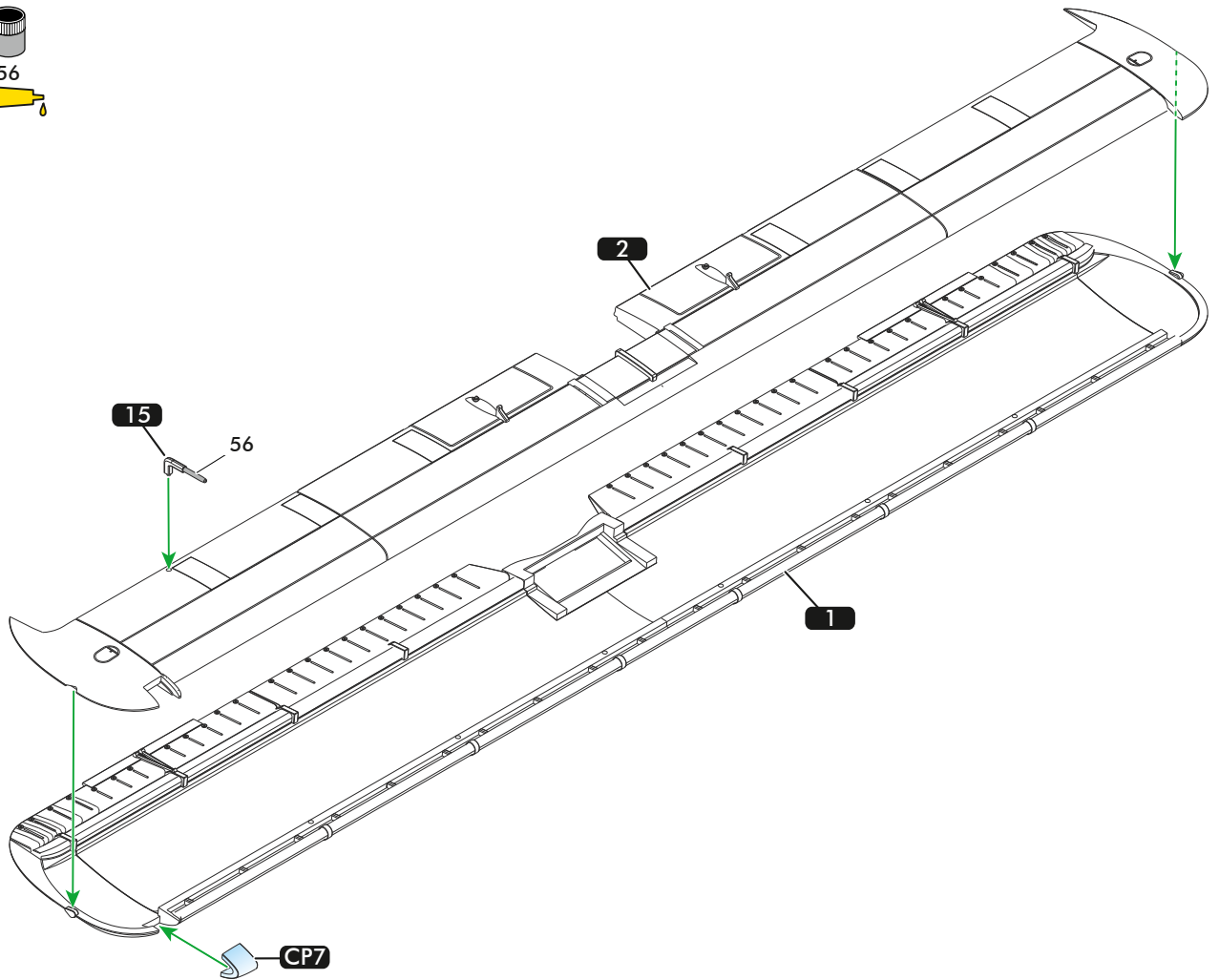

8

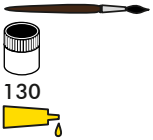

130

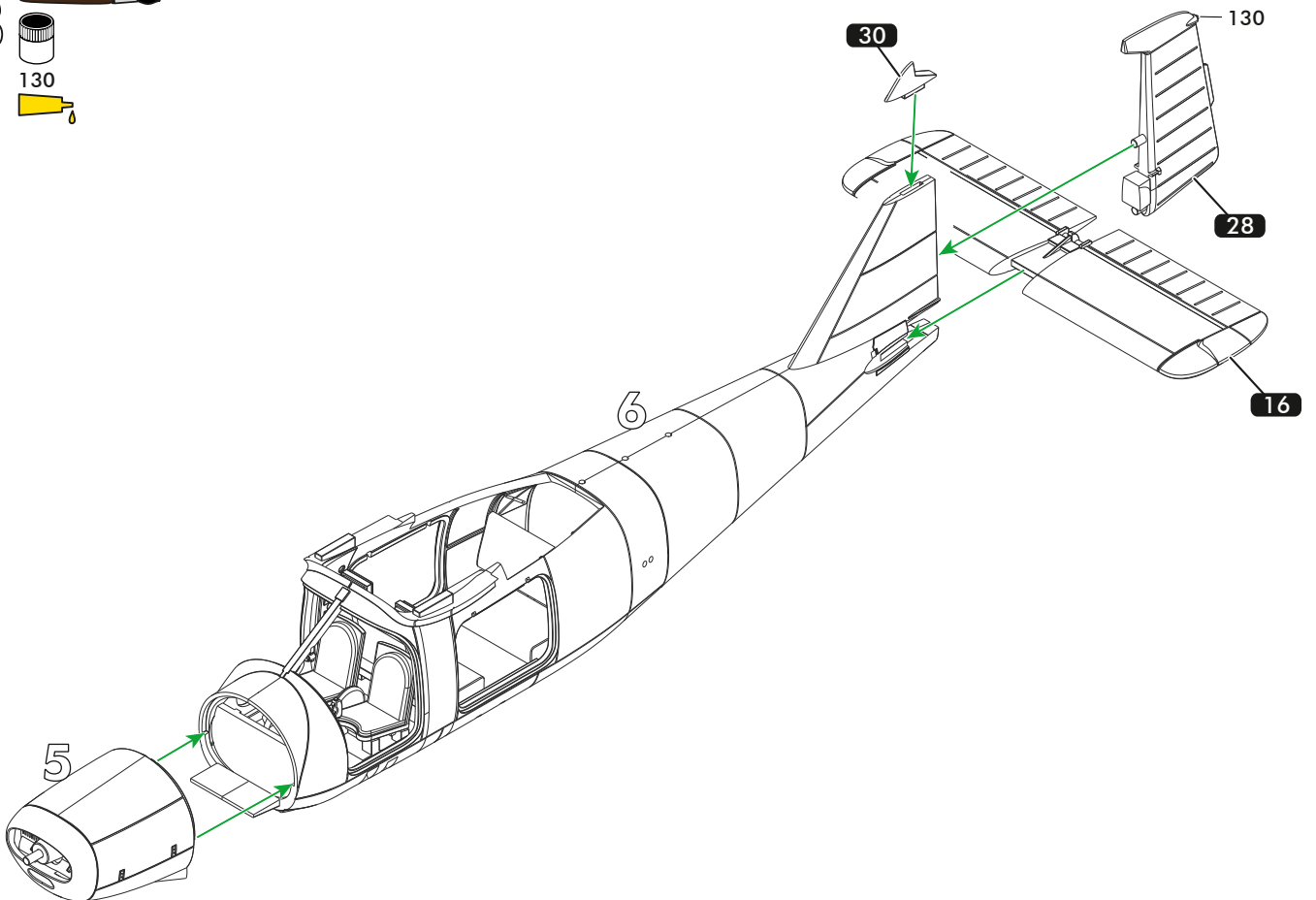

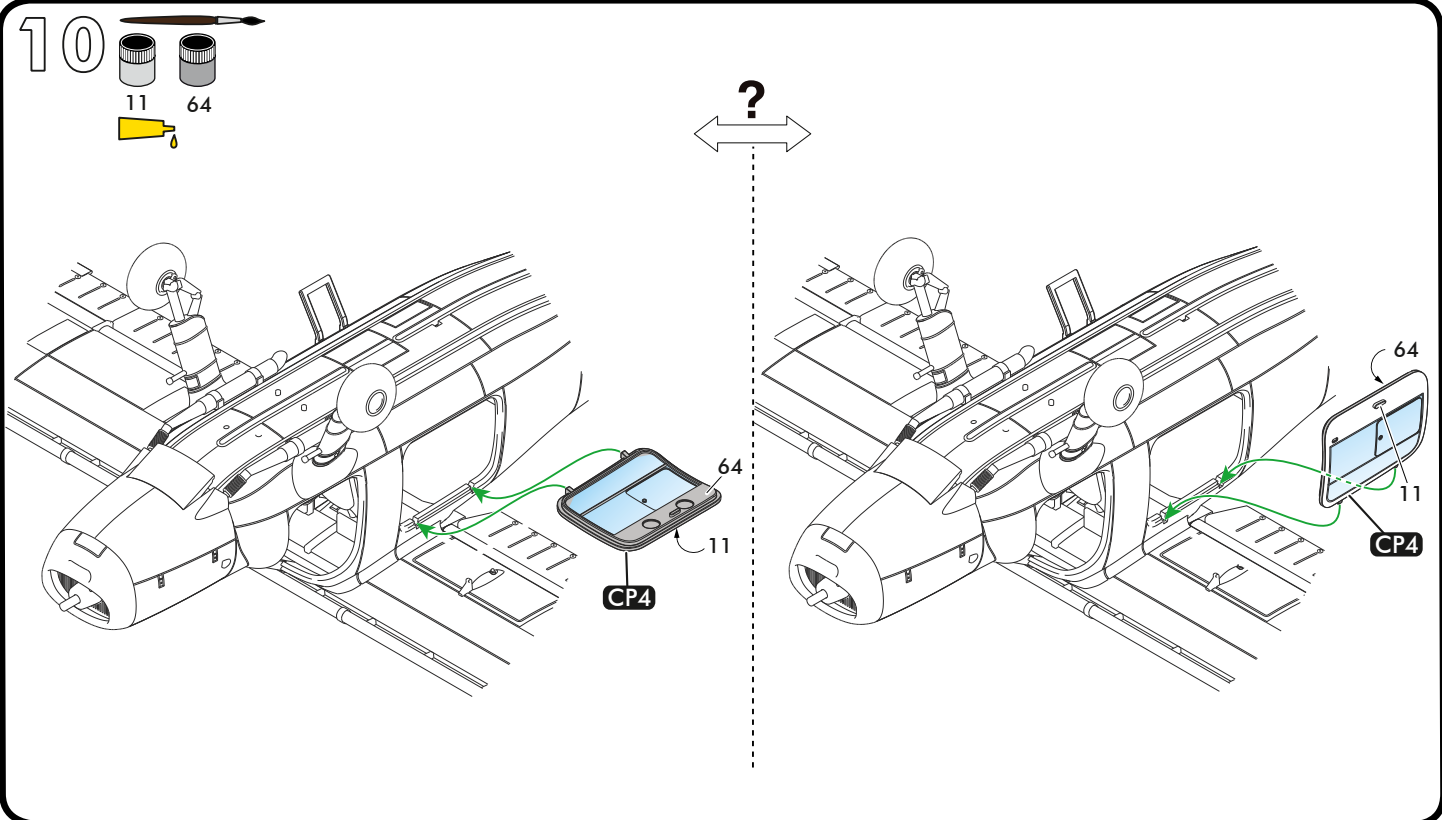
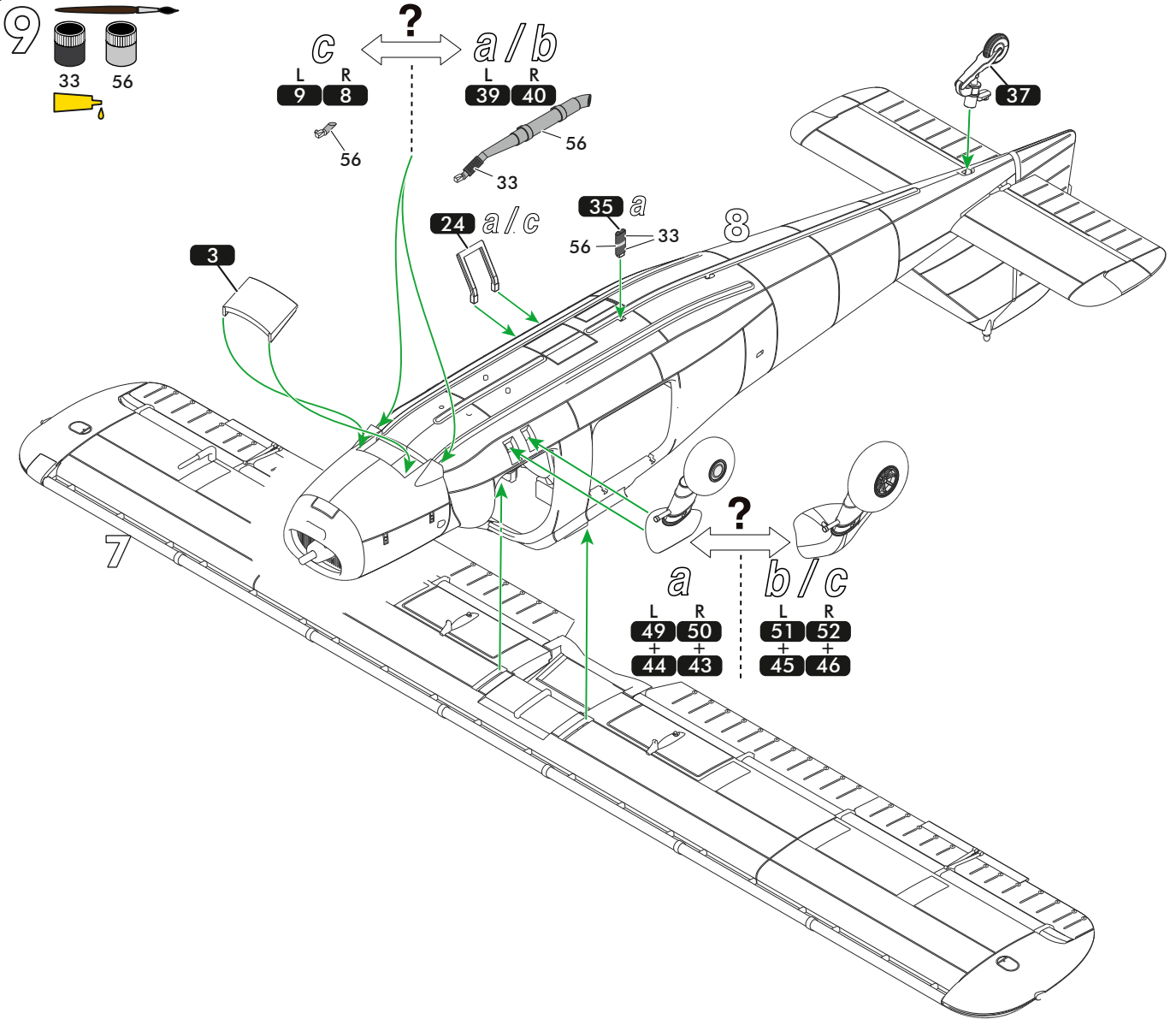

11 

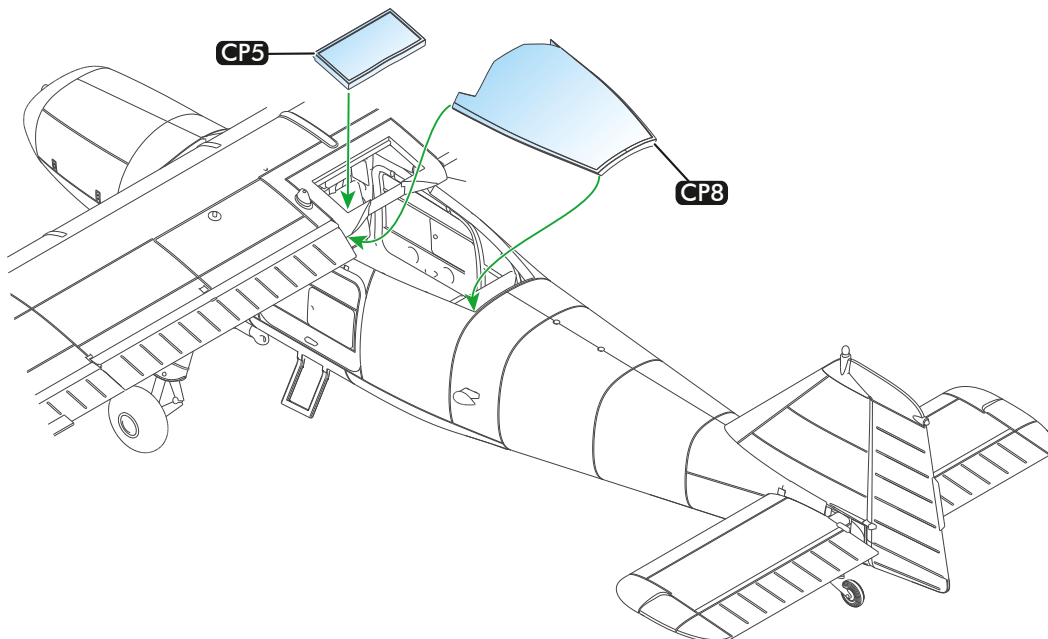

12

- 
- 11
- 33
- 64
- M1

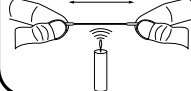

9mm, Ø 1mm

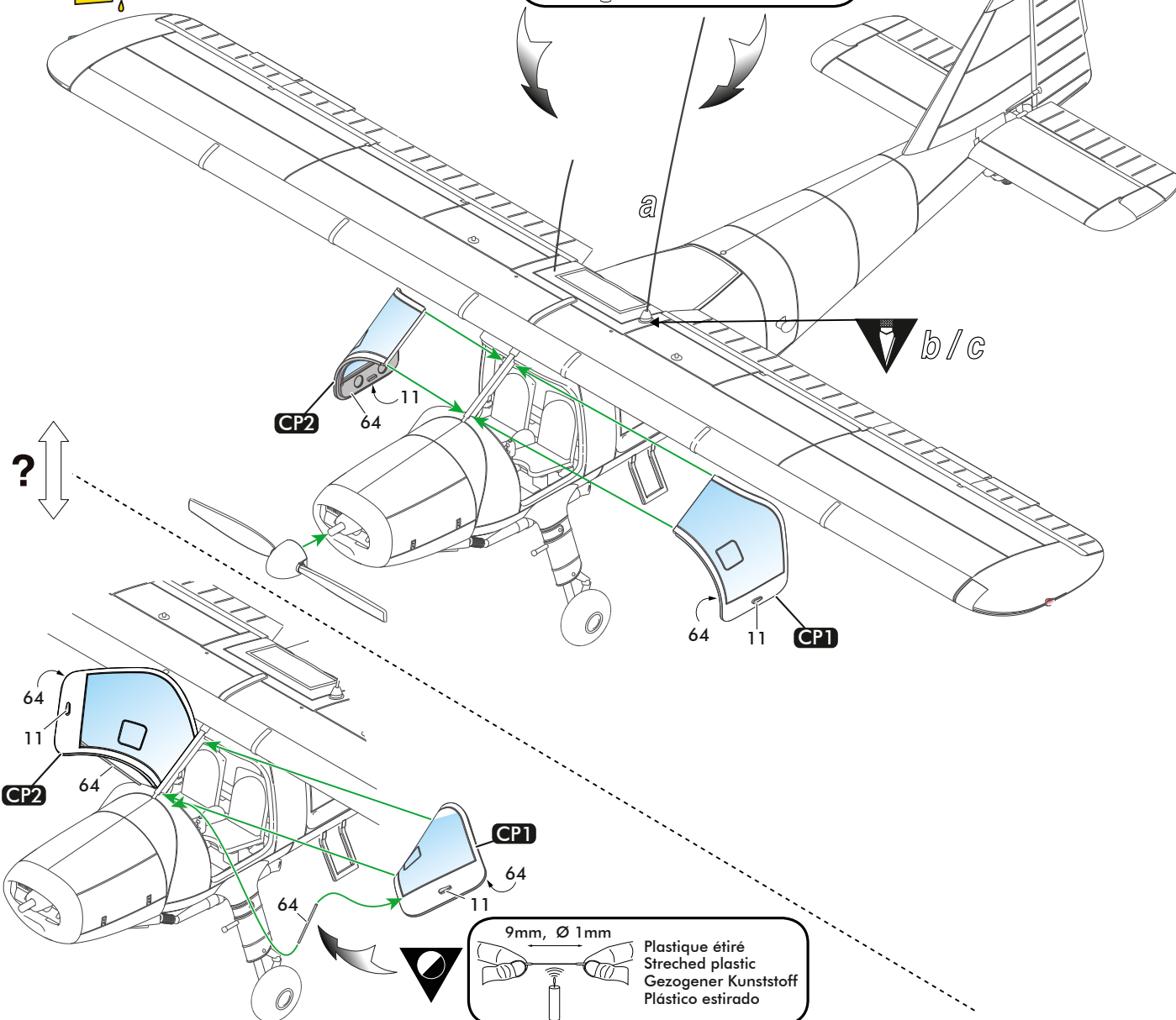
Plastique étiré
Stretched plastic
Gezogener Kunststoff
Plástico estirado

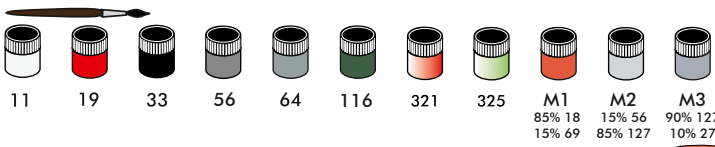

13

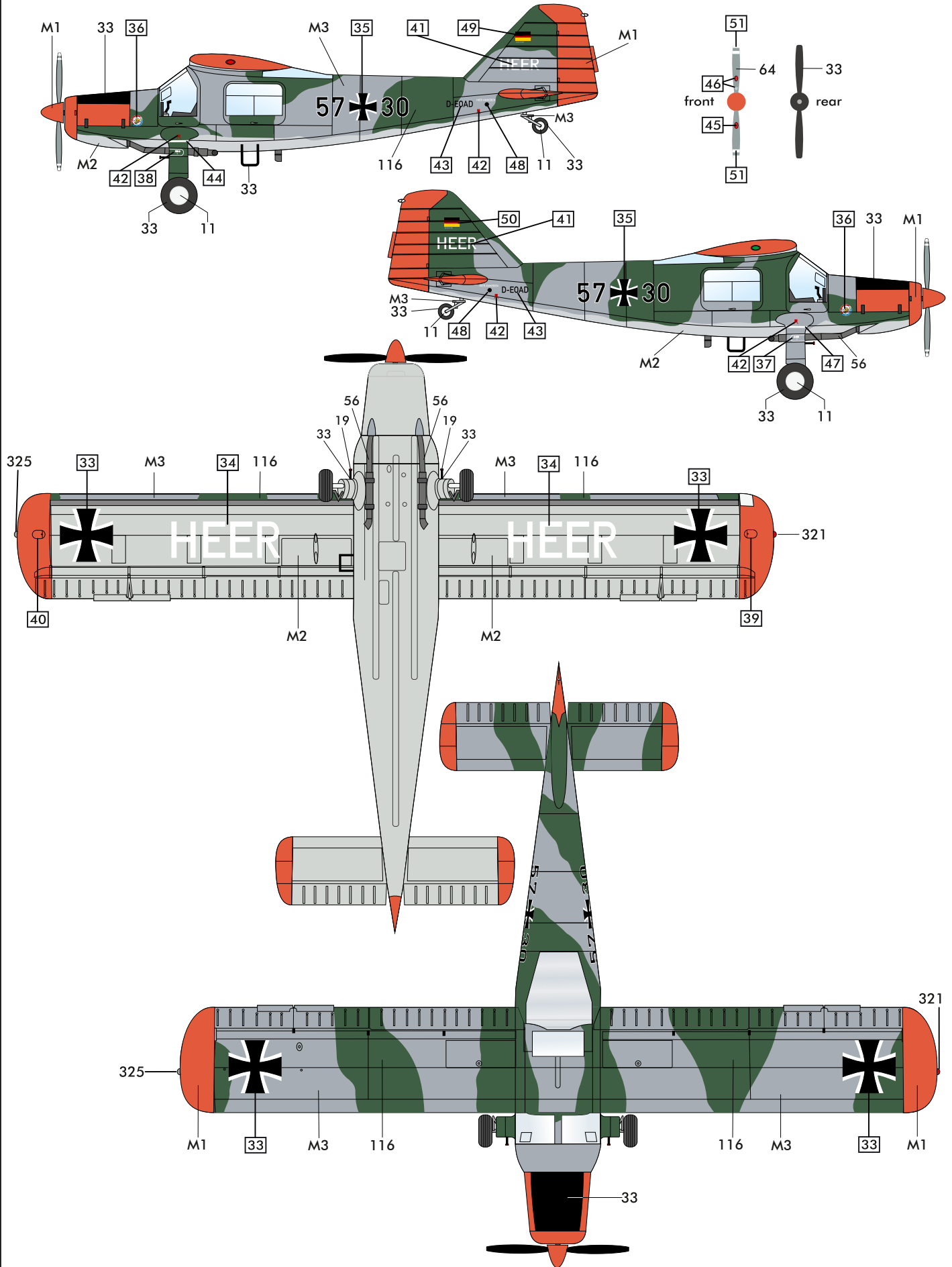

a Do 27, RK Flugdienst Flugplatz Uetersen
Stützpunkt Appen 2019



14

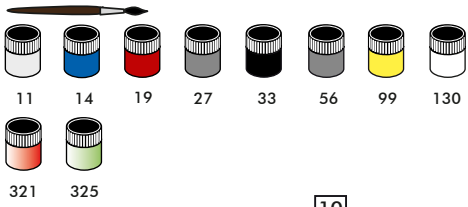

b Do 27, Color variant A: Perpignan Rivesaltes. Juni 2012. France
 Do 27, Color Variant B: Perpignan Rivesaltes. Juni 2020. France

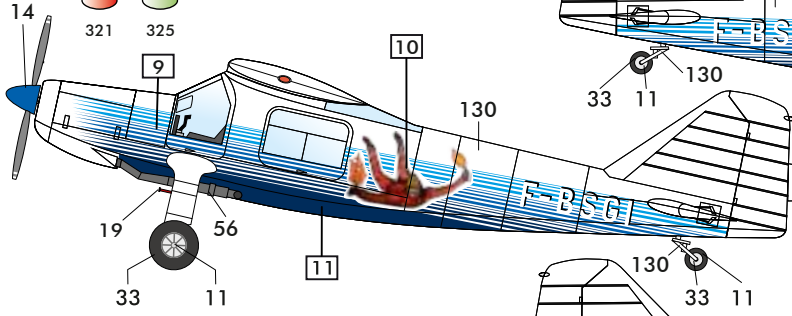

Color variant A

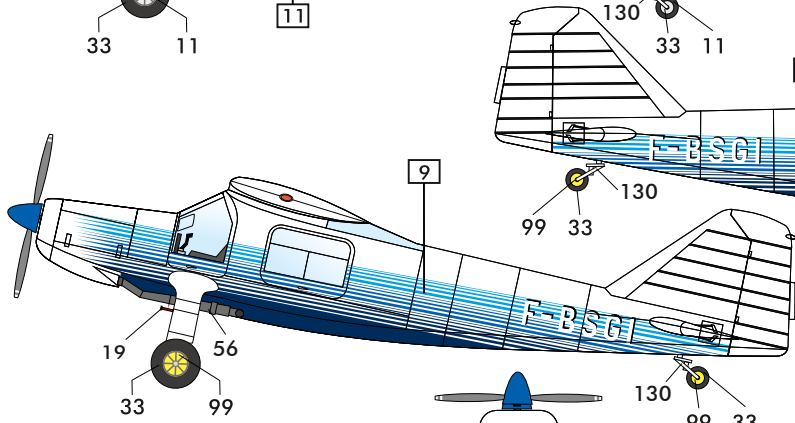
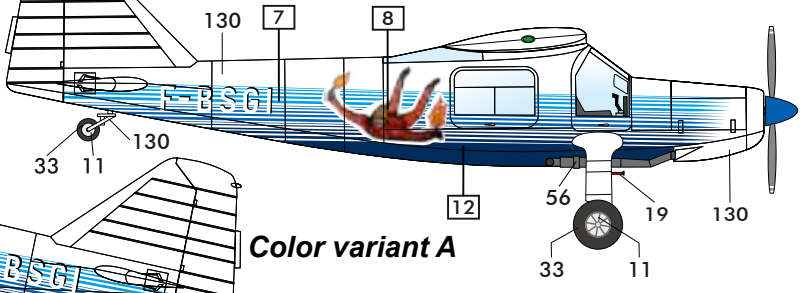

Color variant B

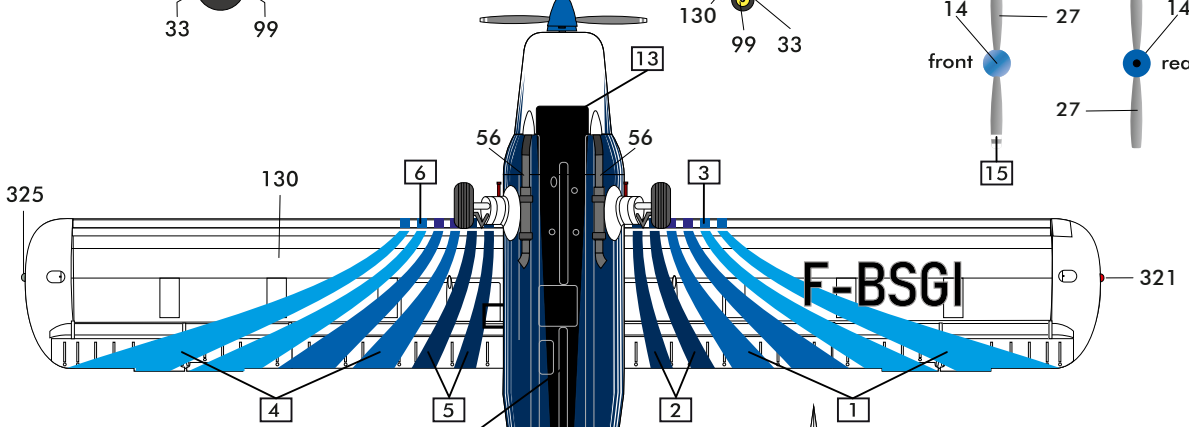
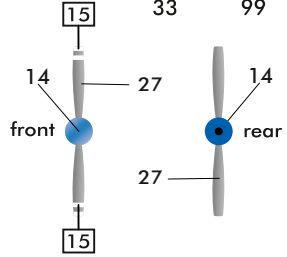
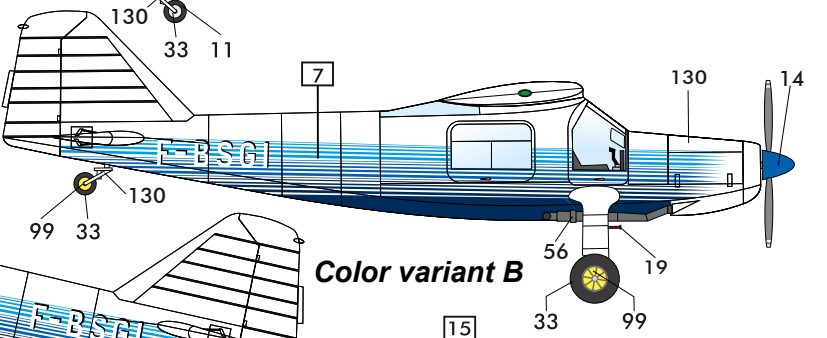

Color variant A/B

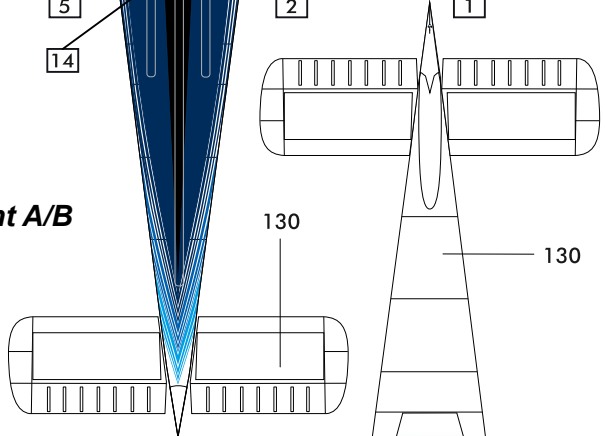

Color variant A/B

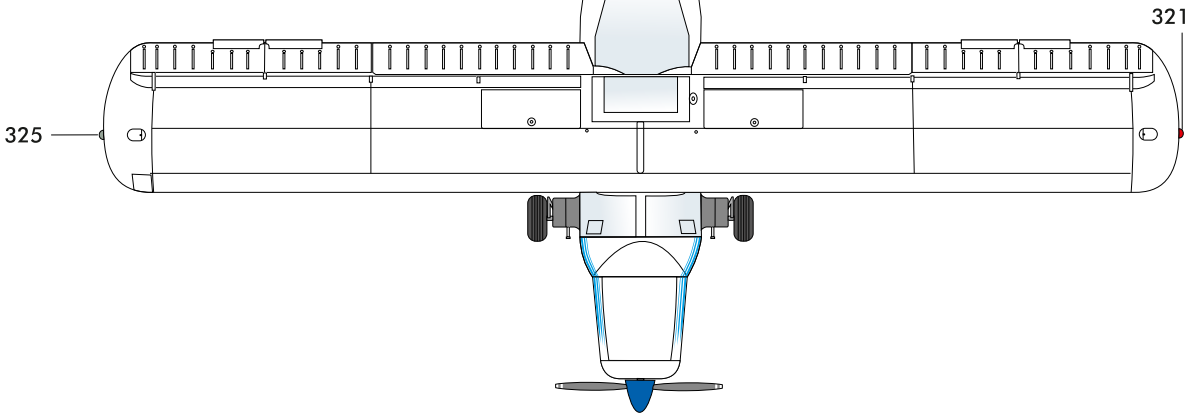

15

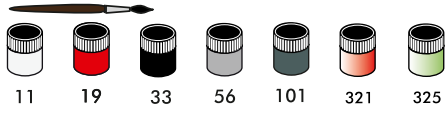

CASA C-127, Spain Air Force,
Military Unit: Ala 23, Spain 1993

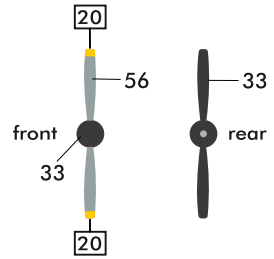
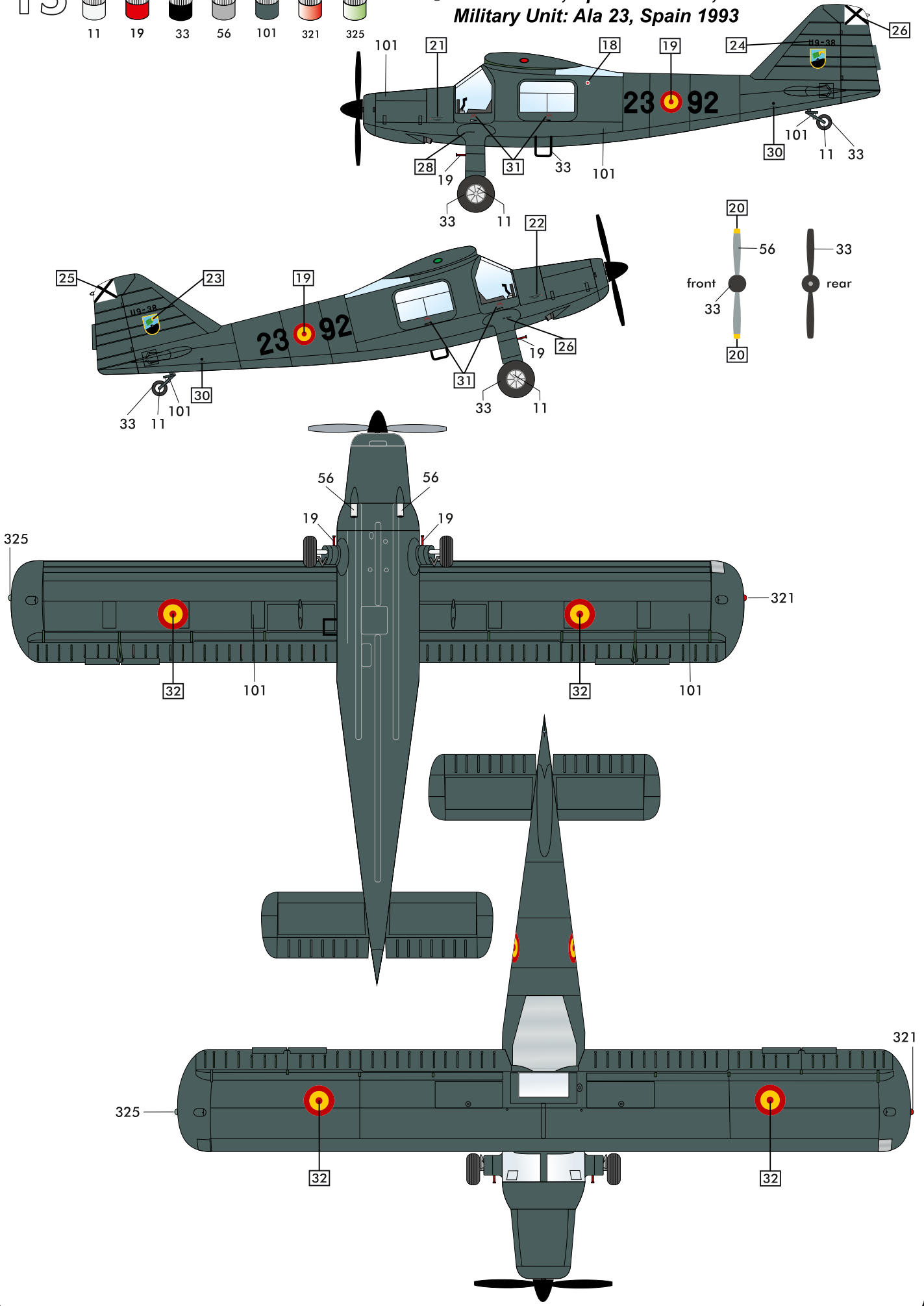

DÉCOUVREZ LE MONDE DES PEINTURES ACRYLIQUES HELLER !

DISCOVER THE WORLD OF HELLER ACRYLIC PAINTS!

ENTDECKEN SIE DIE WELT DER HELLER ACRYL-FARBEN!

NEW



- FACILE À UTILISER
- DILUABLE À L'EAU
- POTS DE PEINTURE STABLES
- BOUCHON À VIS SÉCURISÉ

- EASY TO USE
- DILUTABLE WITH WATER
- STABLE PAINT CANS
- SECURE SCREW CAP

- EINFACHE ANWENDUNG
- MIT WASSER VERDÜNNBAR
- STANDFESTE FARBDOSEN
- SICHERER SCHRAUBVERSCHLUSS

VISITEZ-NOUS EN LIGNE !

VISIT US DIGITALLY!
BESUCHEN SIE UNS DIGITAL!

 www.heller.fr

 [instagram.com/heller.fr](https://www.instagram.com/heller.fr)

 [facebook.com/heller.fr](https://www.facebook.com/heller.fr)



Choisissez l'article désiré et téléchargez la notice de montage.
Choose your desired article and download the instructions.
Wählen Sie den gewünschten Artikel und laden Sie die Anleitung herunter.

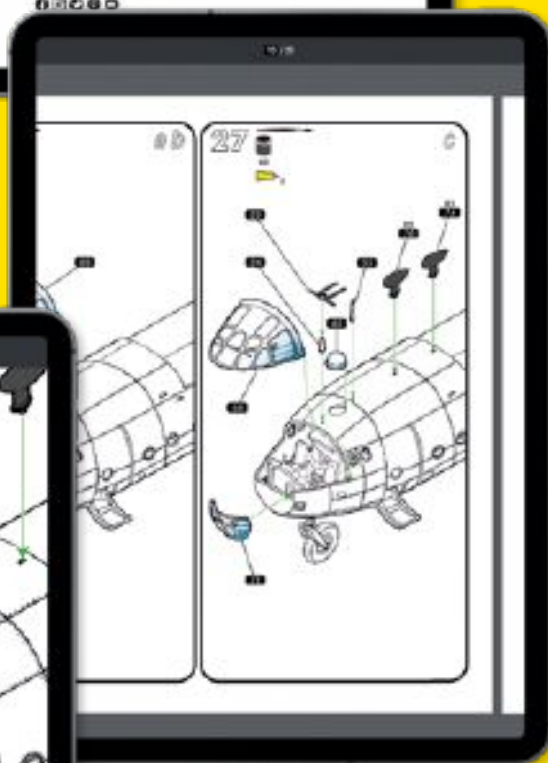

Download all instructions!

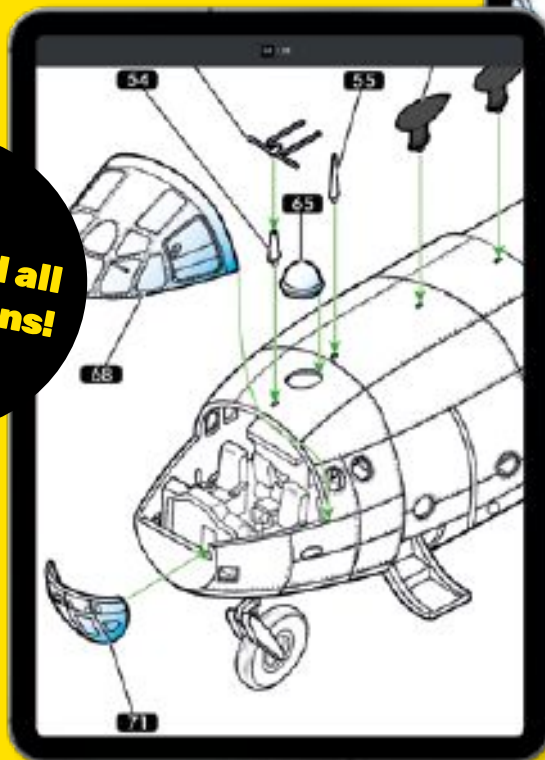

Grossissement des instructions pour une vue détaillée.

Enlarge the instructions for a more detailed view.



Vergrößern Sie die Anleitung für eine detailliertere Ansicht.

V-070922

Service consommateurs
Pour toute demande de SAV, connectez-vous sur notre site www.heller.fr.

Customer Service
For after-sales service requests, please contact us through our website www.heller.fr.

Endverbraucherservice
Bitte besuchen Sie uns auf www.heller.fr für alle Ersatzteilanfragen.

Heller Hobby GmbH
Erlenbacher Str. 3 • 42477 Radevormwald • GERMANY
 +49 (0) 2195-92773-0  info@heller.fr