

P-51D-5 Mustang™

eduard

1/72 Scale Plastic Model Kit



Produced under license

Boeing, P-51 Mustang, their distinctive logos, product markings and trade dress are trademarks of The Boeing Company.

WEEKEND
edition



item # 7476

The P-51 Mustang is one of the best fighters of all time and although an American airplane, its genesis owes a lot to Great Britain. The main change in the development of the type was the replacement of the original Allison engine with the Merlin one. The new unit literally unlocked the whole potential of the already excellent airframe.

It started in 1940, when British Buying Committee asked North American Aviation (NAA) to build the Curtiss P-40s for the RAF. NAA president James Kindelberger offered Britons the development of a much better plane instead. The Committee agreed and so the design team led by chief designer Edward Schmuied, who was a German immigrant with Austrian roots, started to work. The preliminary design was approved on May 4, 1940, final assembly and engine installation began on September 9 (just 127 days after approval) and the first flight of the NA-73X prototype followed on October 26.

Innovative fighter

The Allison V-1710-39 one-stage, one-speed supercharged liquid-cooled in-line engine rated at 1,100 HP was chosen for the new fighter and the designers creating as narrow and sleek a fuselage as possible did their best to lower the drag. For the same reason they decided to use an innovative laminar flow airfoil, which lowers the drag indeed, but, on the other hand, requires a smooth surface to work well. That necessitated putty and sand the leading area of the wing. Another innovative design feature was the radiator belly under the fuselage which even developed some additional thrust thanks to the Meredith effect.

Armament consisted of two guns in the nose and four in the wings, all of them .50 caliber Brownings (the Mk. Ia variant had four 20mm cannons). Britons chose the name Mustang for the new aircraft, later adopted by USAAF as well. The RAF received the first Mustangs Mk.I in October 1941. The performance was found satisfactory, as the Mustang was faster than the Spitfire Mk.V and had more than double the range. On the other side, the Allison engine reached its maximum power at only 11,800 ft (3,597 m) because of its one stage supercharger. Above this level the engine performance decreased rapidly. As the aerial combats occurred much higher, the RAF decided to use their Mustangs in the reconnaissance role and the US Army Air Corps, interested in the new type as well (but bound to the contract to build P-40, P-39 and P-38 pursuits), asked the NAA to convert the Mustang as a dive bomber with wing dive brakes (the A-36 variant).

Merlin magic

To solve the high altitude weakness, the work began in Great Britain to fit the Mustang with the two-stage, two-speed Merlin 61 engine. The trials of the Mustang X prototype, fitted with Merlin 65 finally, found the level speed increased to 433 mph (697 km/h) at 22,000 ft (6700 m), 100 mph (161 km/h) faster than Mustang Mk.I. As it was

obviously the way to further develop the Mustang, NAA started its own work, using license built Packard-Merlin engine. The need for an intercooler for the two-stage supercharger necessitated a bigger radiator duct. Another change included the removal of the fuselage guns. The production started at the Inglewood plant as P-51B in May 1943 and at the new production line at NAA Dallas plant as P-51C in August 1943.

The P-51B/C were great fighters but lacked backward visibility and suffered with gun jamming. The RAF found some improvement to the visibility issue with a "Malcolm Hood" semi-bubble canopy, but the design team of NAA decided to rework the Mustang again. The main change was the bubble canopy with lowered rear fuselage. The wing was reworked to accommodate six .50 cal guns, and the new arrangement of ammo chutes eliminated the jam problem. Together with some other changes, the new P-51D was born at the end of 1943 and production started at both Inglewood (serials with -NA suffix) and Dallas (-NT) plants. Due to the short supply of the Hamilton Standard alloy propellers used on Merlin powered P-51s, the Dallas Factory was fitting Aeroproduct ones with steel hollow blades to their Mustangs, these being marked P-51K. In total, 8,102 units of P-51D and 1,500 of P-51K were produced.

Ace maker and infinite warrior

The first Mustang aerial victory was achieved on August 19, 1942, when Flight Officer Hills shot down an Fw 190. It was the beginning of the incredible tally of 4,950 enemy aircraft shot down by Mustang pilots during World War II. Of them, 251 achieved the "ace" status. The most successful pilot of P-51 was George Preddy Jr., who recorded 24 of his 27 aerial victories with Mustang. Famous Charles Yeager, the first man to break the sonic barrier in 1947, was the first pilot of P-51D to become ace in just one day, after recording five kills on October 12, 1944.

The kit: P-51D-5 Mustang

The D-5 was the first production batch apart of the -1NA (100 unassembled Mustangs shipped for Australia). There were 800 P-51D-5NA produced at Inglewood and the Dallas plant added 200 of P-51D-5NT. The 5 series was the only to retain the shape of the vertical fin from P-51B/C. But as the lowered fuselage behind the bubble canopy reduced the rearside surface area, the directional stability of P-51D suffered. Due to that, starting with the P-51D-10 series, the dorsal fin was added to the stabilizer to remedy the problem and the field conversion kit was distributed to the units already using P-51D-5s.

ATTENTION



UPOZORNĚNÍ



ACHTUNG



ATTENTION



注意



Carefully read instruction sheet before assembling. When you use glue or paint, do not use near open flame and use in well ventilated room. Keep out of reach of small children. Children must not be allowed to suck any part, or pull vinyl bag over the head.



Před započítím stavby si pečlivě prostudujte stavební návod. Při používání barev a lepidel pracujte v dobře větrané místnosti. Lepidla ani barvy nepoužívejte v blízkosti otevřeného ohně. Model není určen malým dětem, mohlo by dojít k požití drobných dílů.

INSTRUCTION SIGNS



INSTR. SYMBOLY



INSTRUKTION SINNBILDEN



SYMBOLES



記号の説明

OPTIONAL
VOLBABEND
OHNOUTSAND
BROUSITOPEN HOLE
VYVRTAT OTVORSYMETRICAL ASSEMBLY
SYMETRICKÁ MONTÁŽREMOVE
ODRÍZNOUTREVERSE SIDE
OTOČITAPPLY EDUARD MASK
AND PAINT
POUŽÍT EDUARD MASK
NABARVIT

PLEASE CHECK THE LATEST VERSION OF THE INSTRUCTIONS ON www.eduard.com

PARTS



DÍLY



TEILE



PIÈCES



部品

PLASTIC PARTS

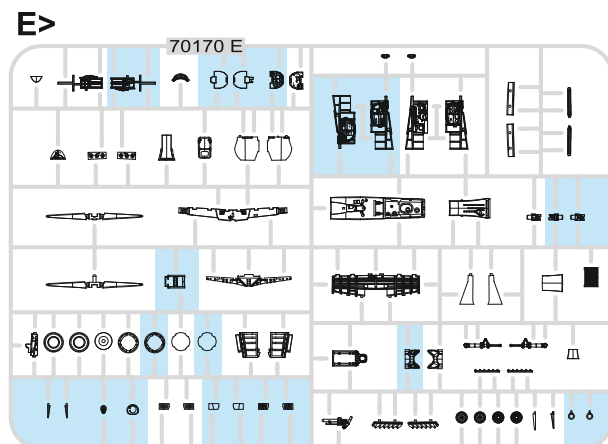
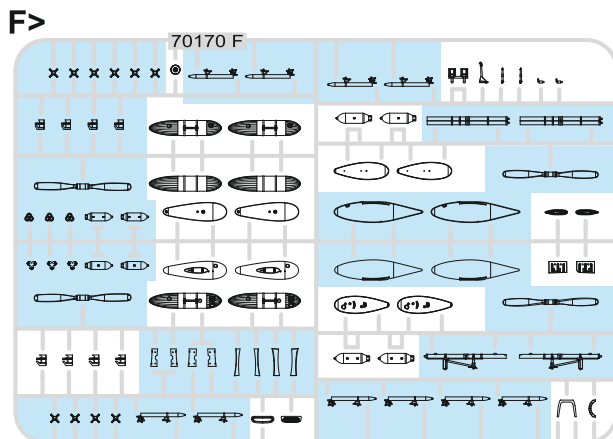
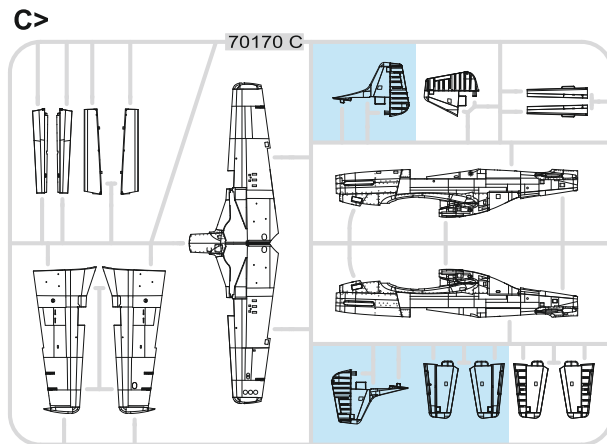
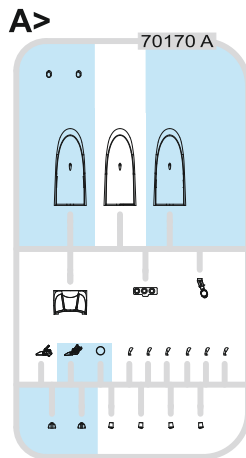

-Parts not for use. -Teile werden nicht verwendet. -Pièces à ne pas utiliser. -Tyto díly nepoužívejte při stavbě. - 使用しない部品

COLOURS



BARVY



FARBEN



PEINTURE



色

GSI Creos (GUNZE)		
AQUEOUS	Mr.COLOR	
H1	C1	WHITE
H8	C8	SILVER
H11	C62	FLAT WHITE
H12	C33	FLAT BLACK
H15	C65	BRIGHT BLUE
H37	C43	WOOD BROWN
H47	C41	RED BROWN
H52	C12	OLIVE DRAB
H53	C13	NEUTRAL GRAY
H58	C351	INTERIOR GREEN
H76	C61	BURNT IRON

GSI Creos (GUNZE)		
AQUEOUS	Mr.COLOR	
H77	C137	TIRE BLACK
H90	C47	CLEAR RED
H92	C49	CLEAR ORANGE
H94	C138	CLEAR GREEN
H327	C327	RED
H329	C329	YELLOW
	C352	CHROMATE YELLOW
Mr.COLOR SUPER METALLIC		
	SM201	SUPER FINE SILVER
	SM203	SUPER IRON

RECTANGLE PLASTIC ROD
cross section - 0,5 × 0,3 mm
l - 5,2 mm

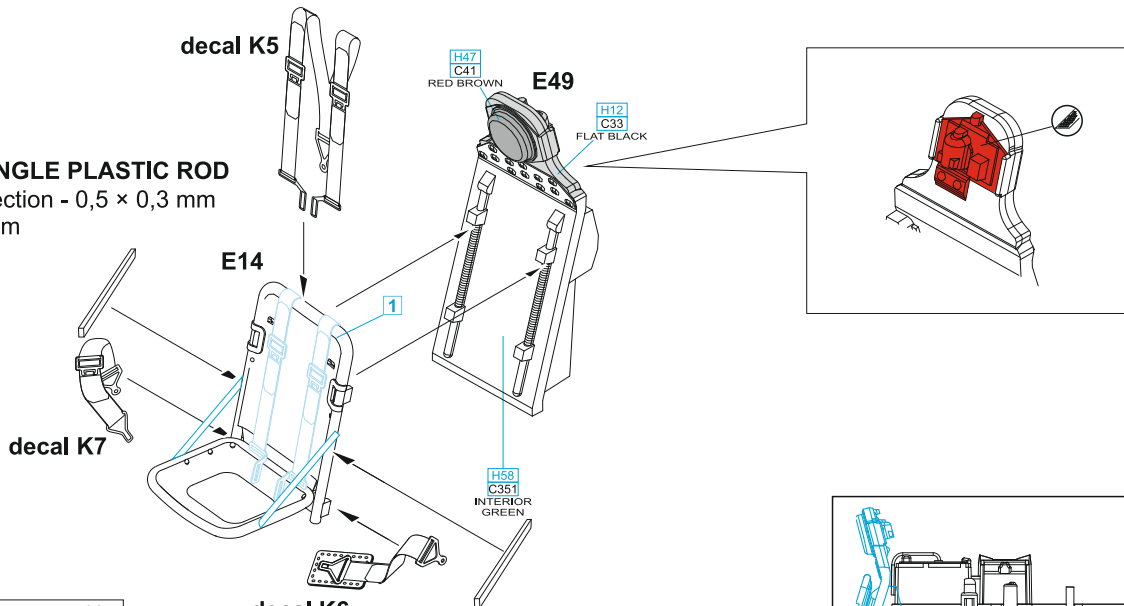

RECTANGLE PLASTIC ROD
cross section - 0,5 × 0,3 mm
l - 5,2 mm

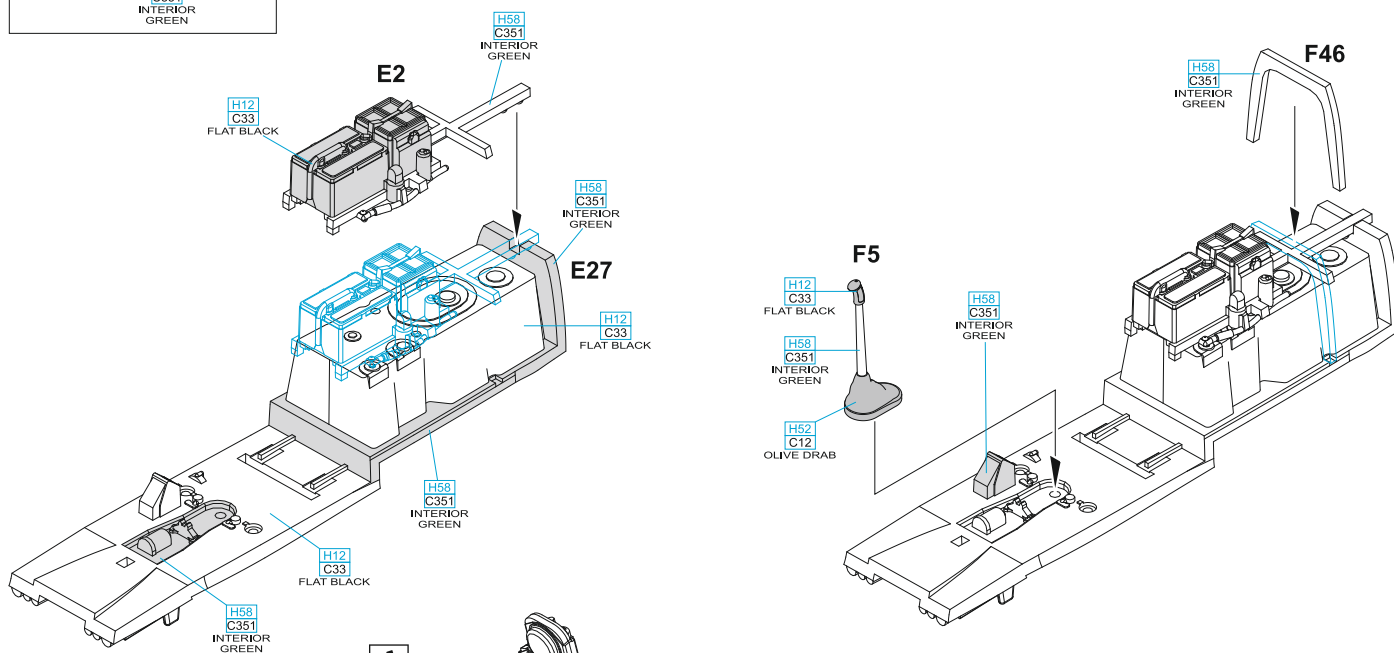
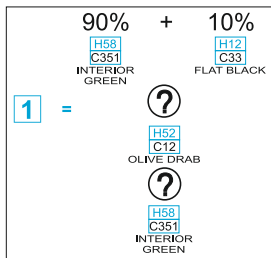
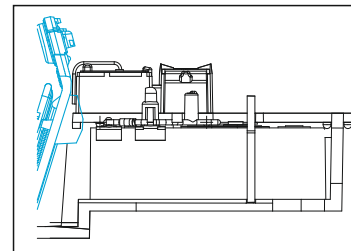

A

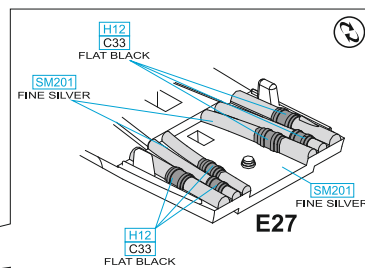
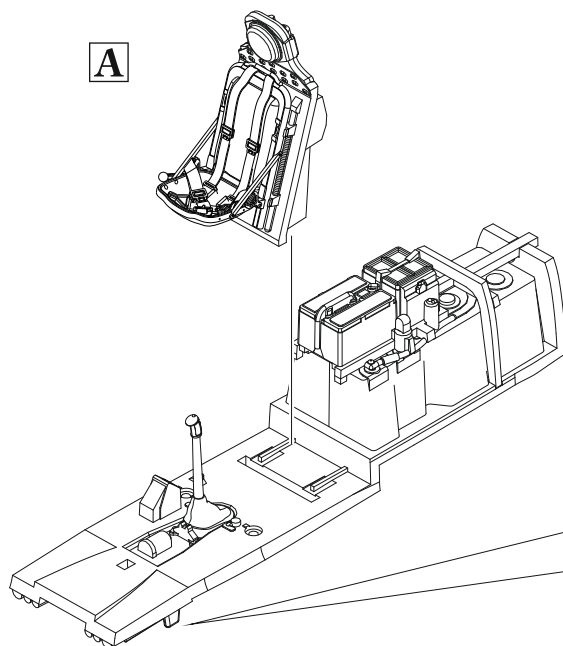

BOTTOM OF PART E27

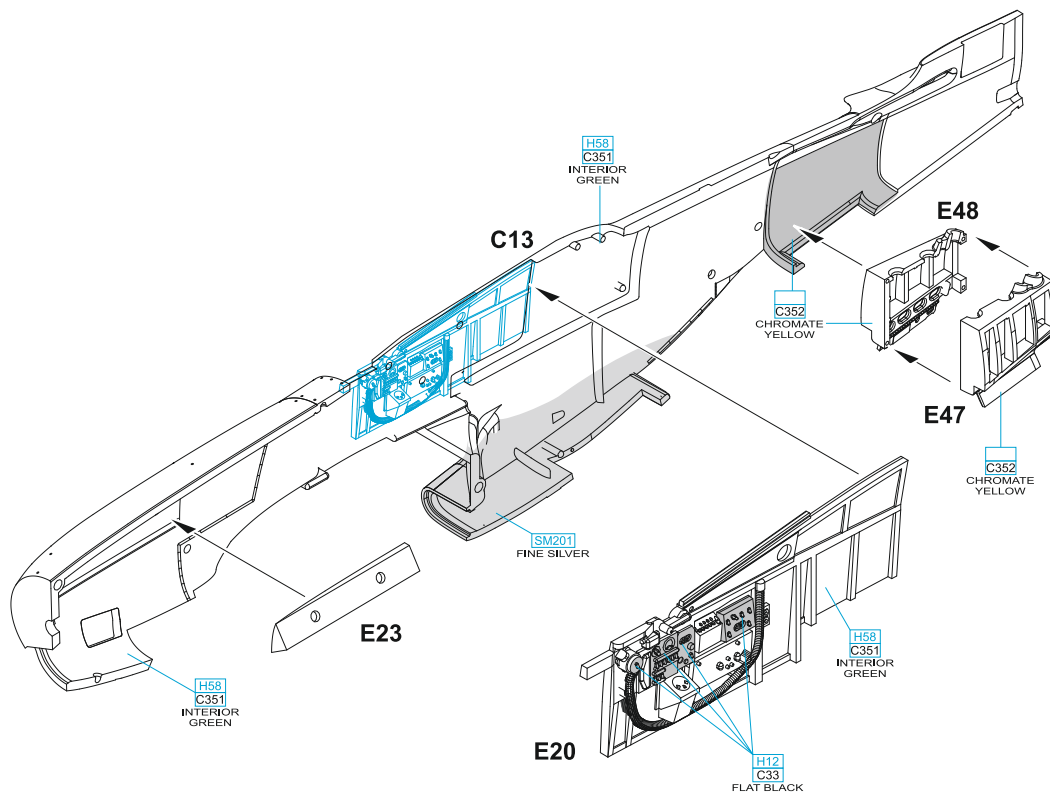
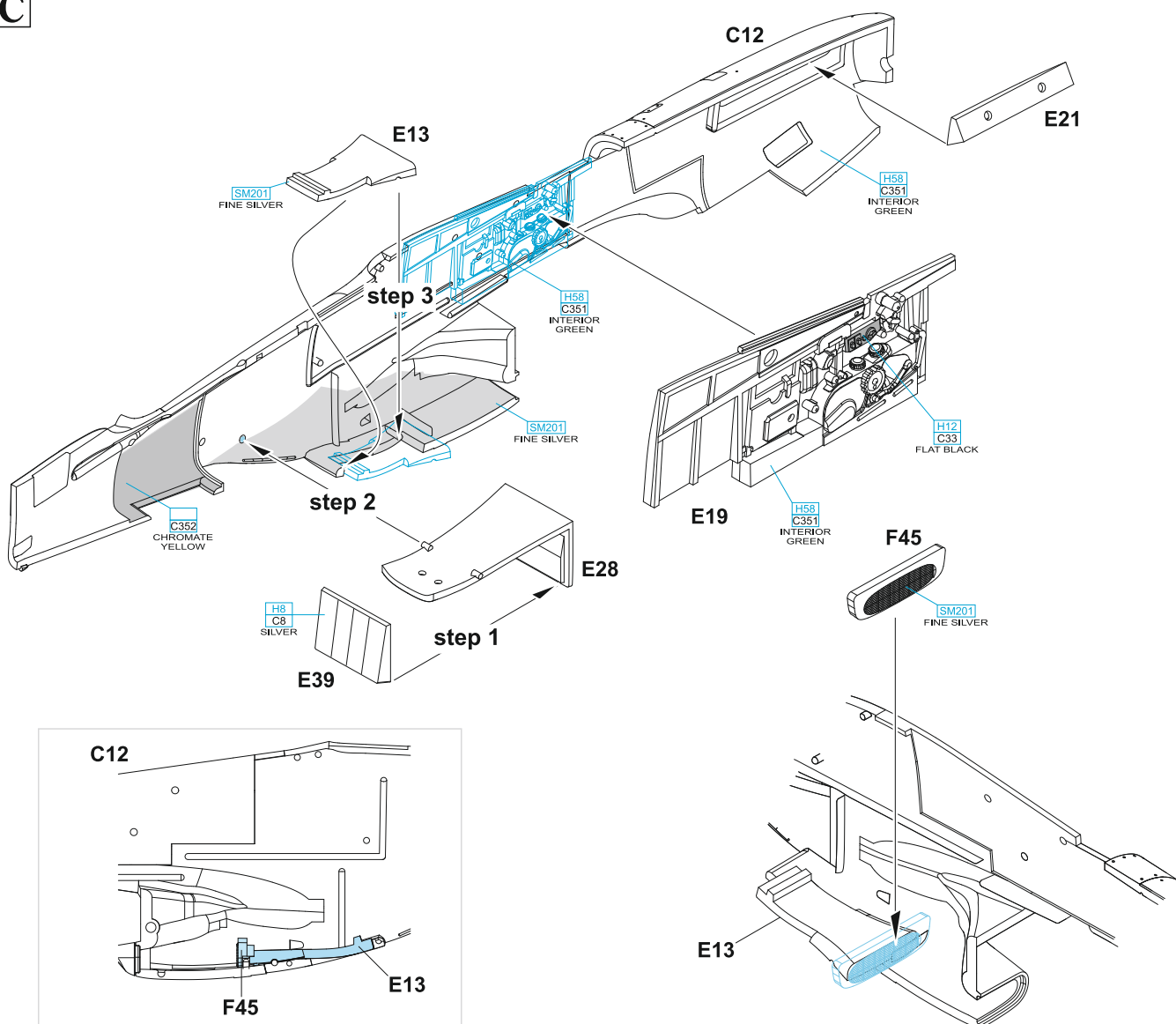
B**C**

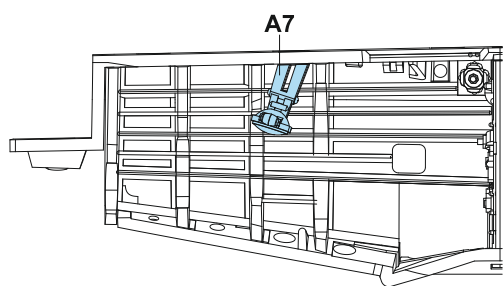
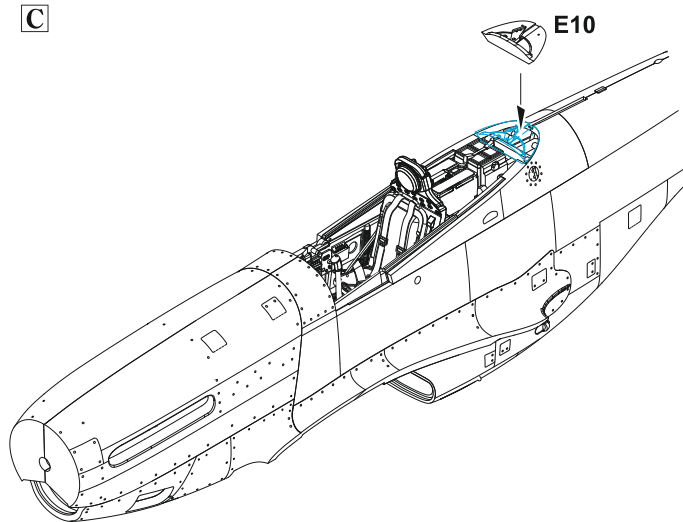
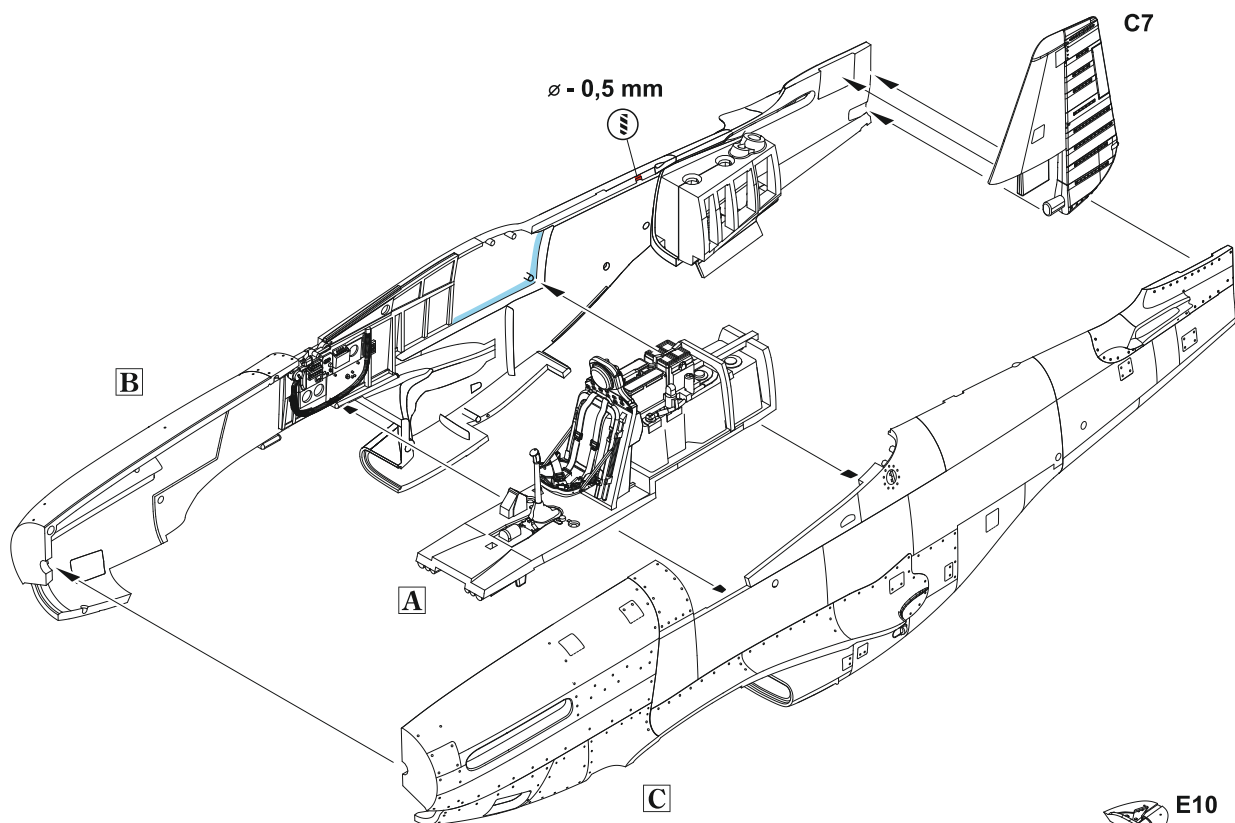

D

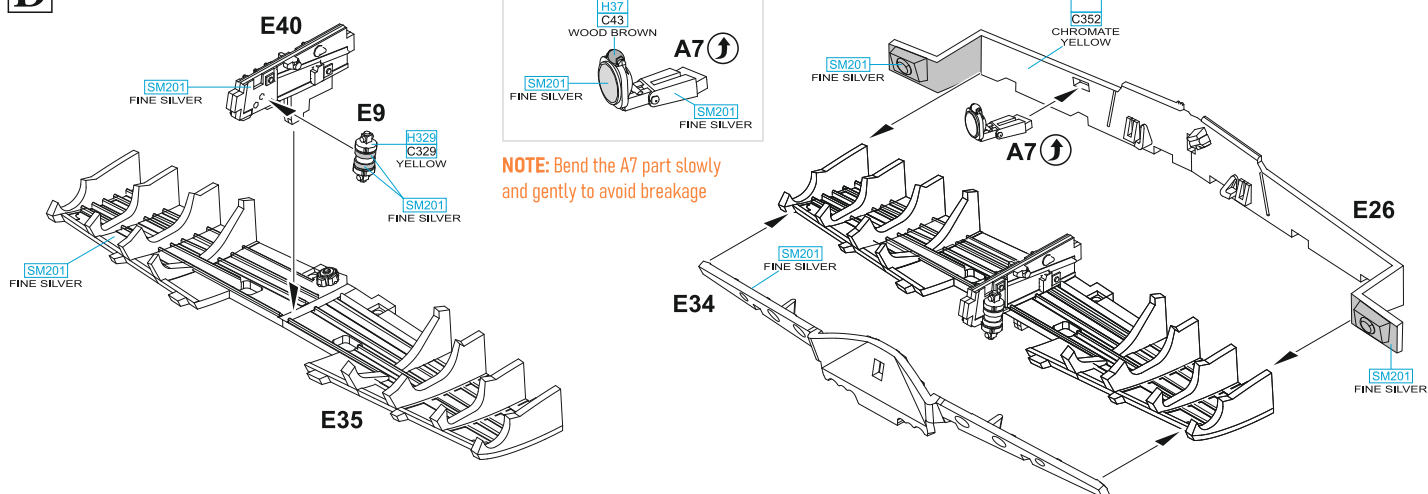

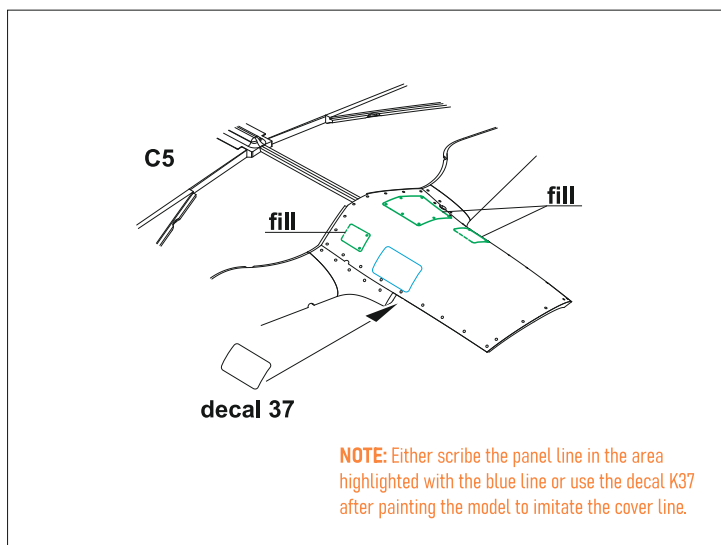
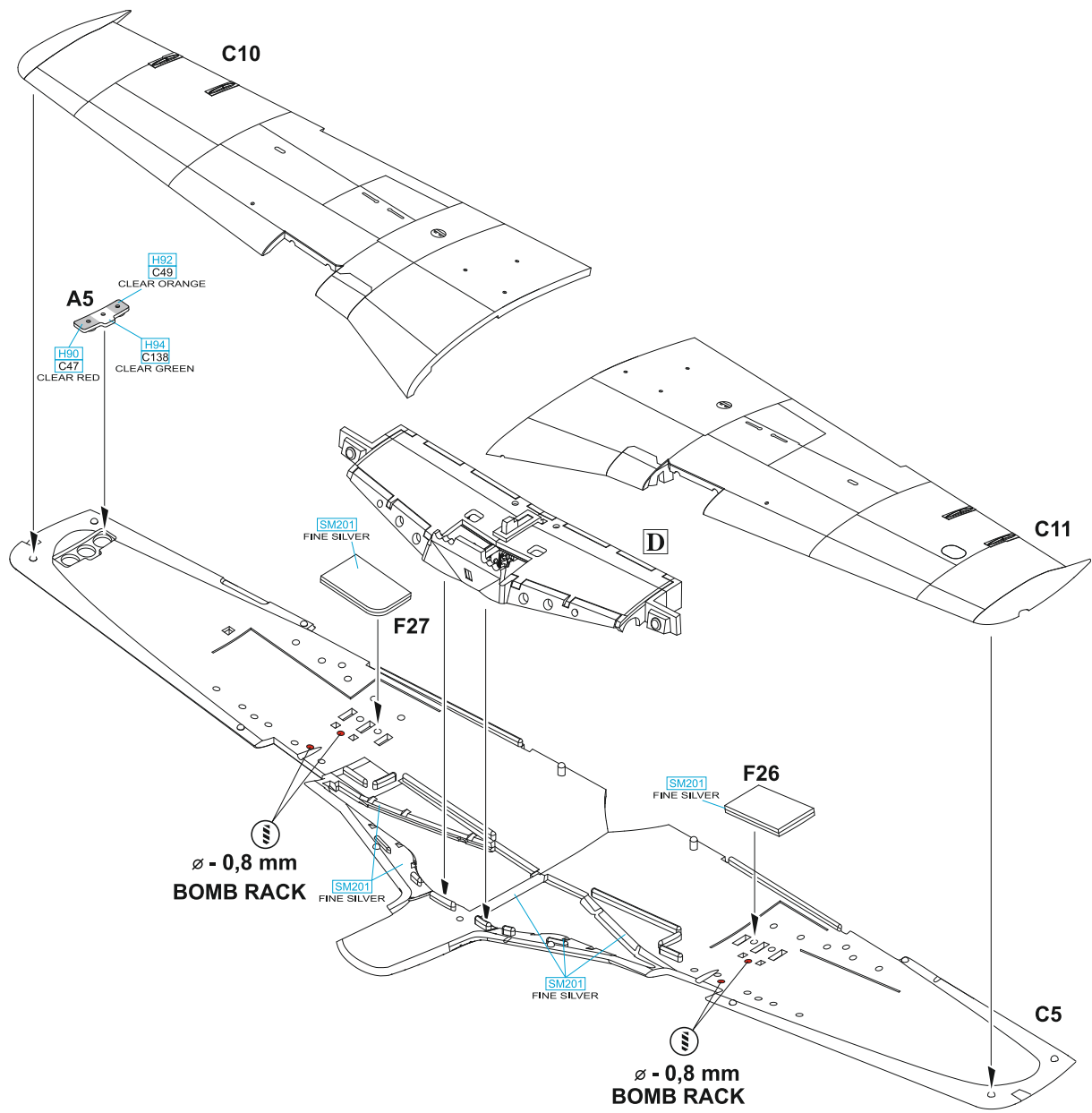

NOTE: Either scribe the panel line in the area highlighted with the blue line or use the decal K37 after painting the model to imitate the cover line.

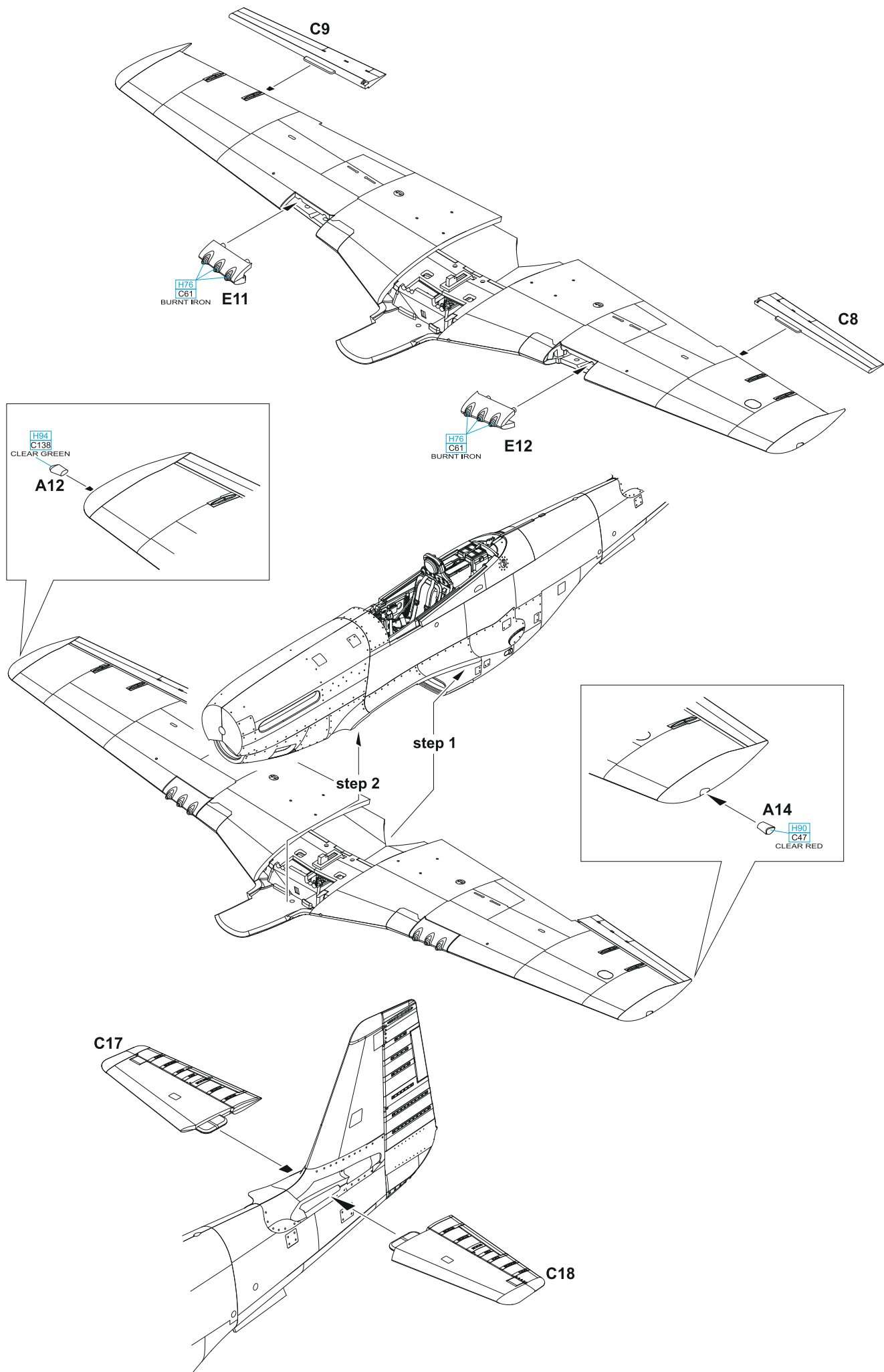

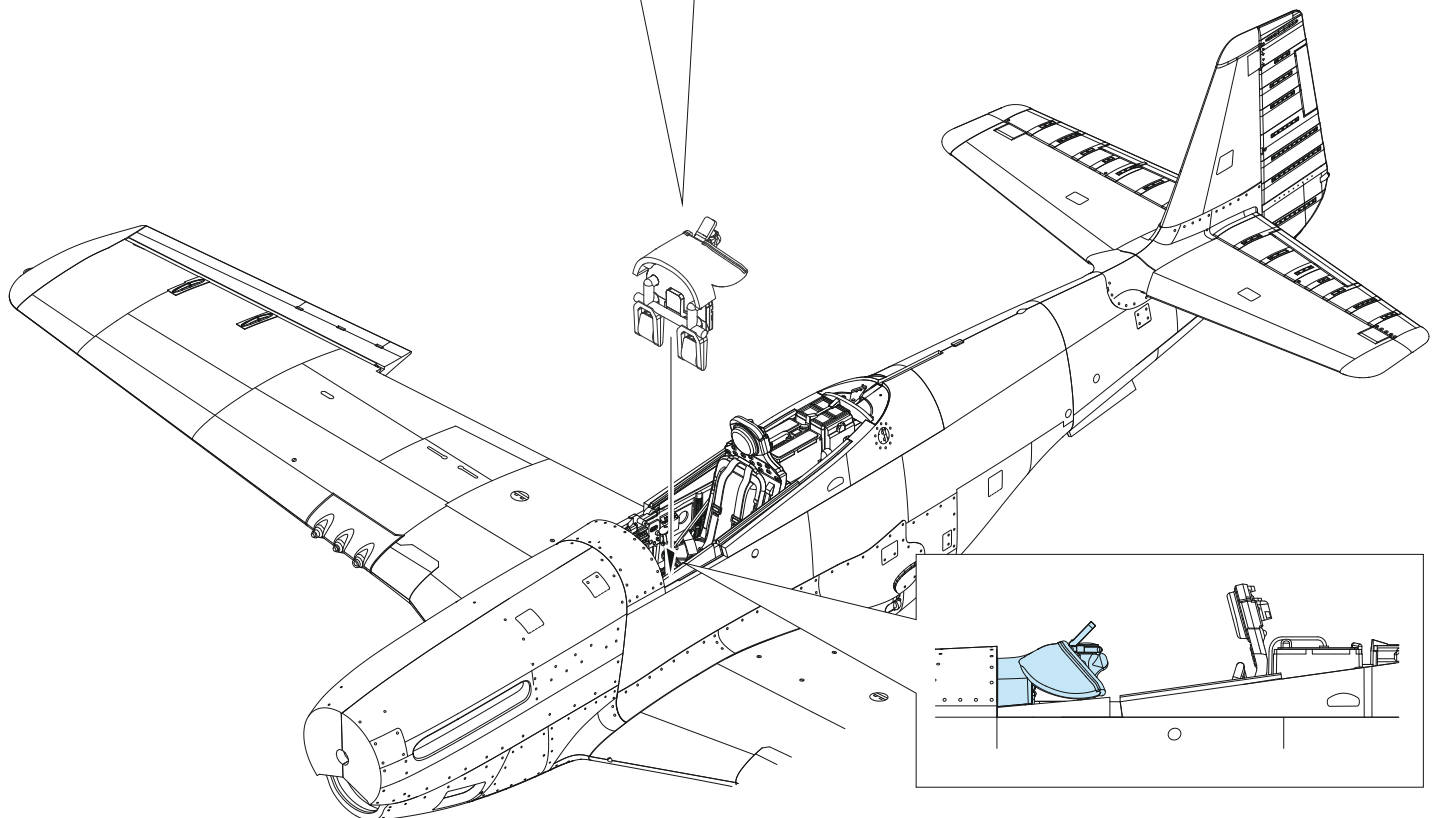
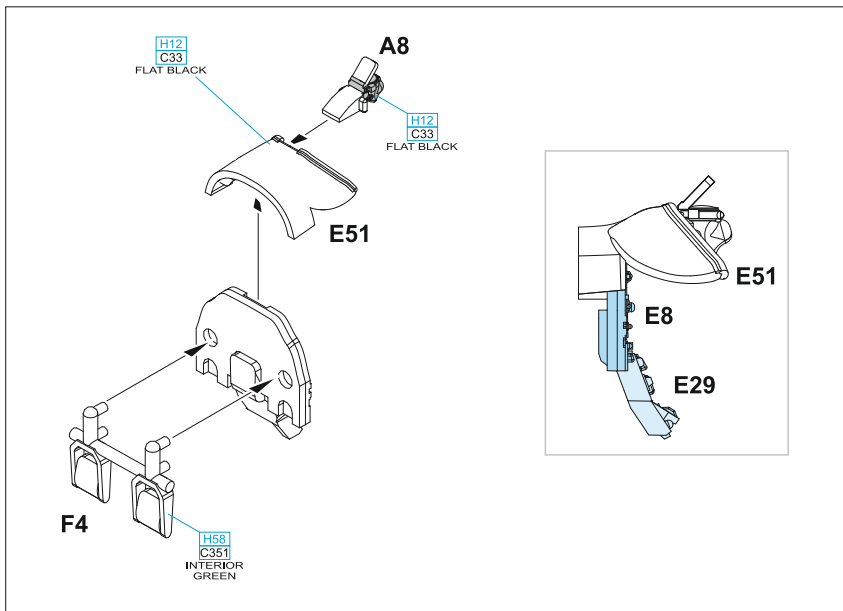
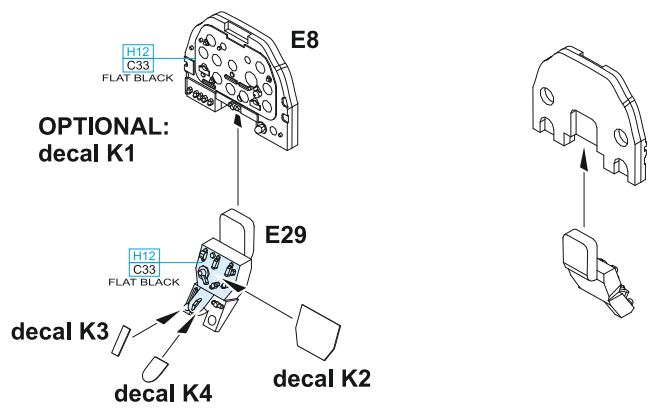

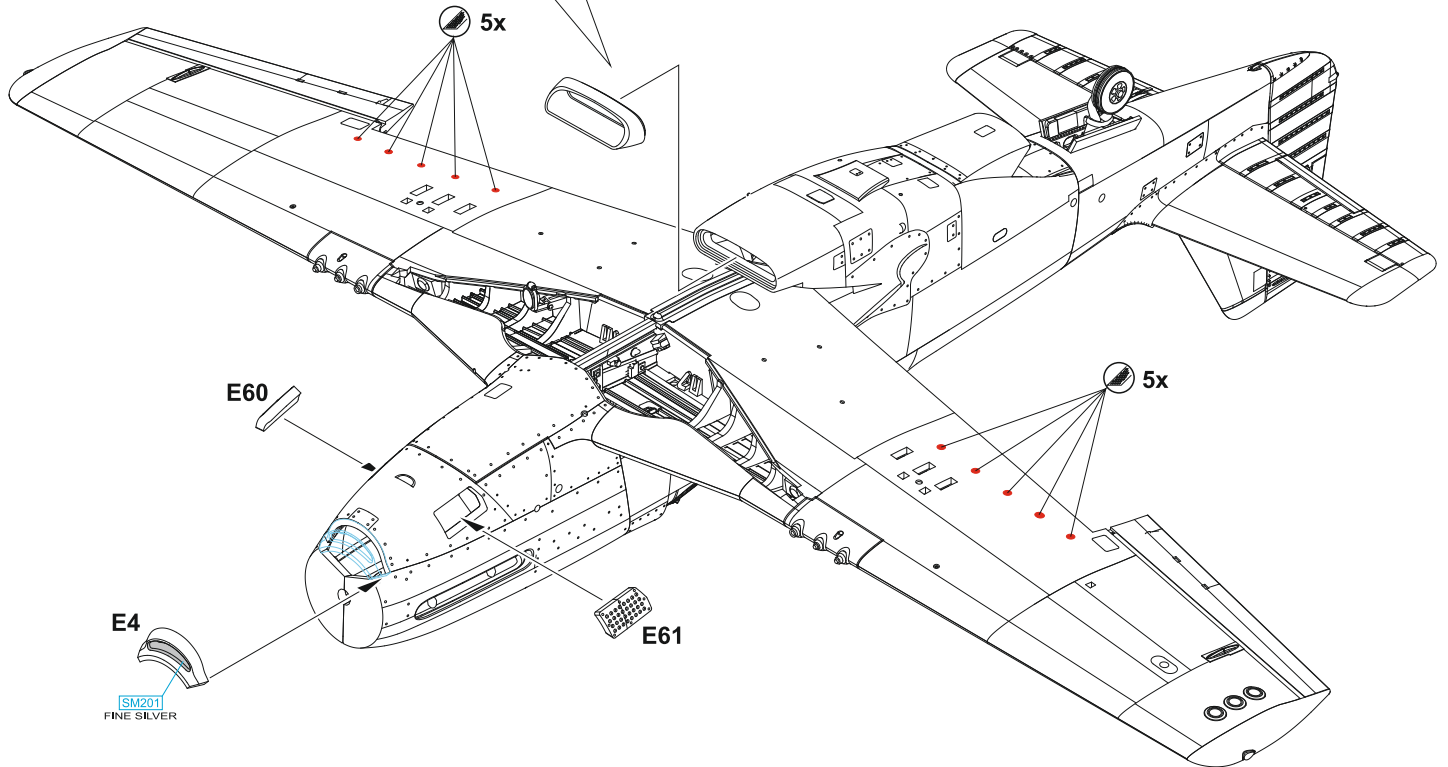
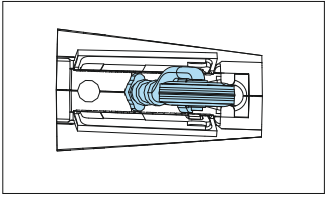
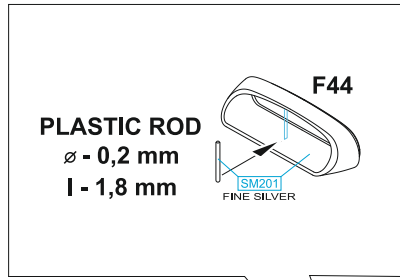
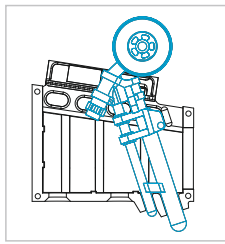
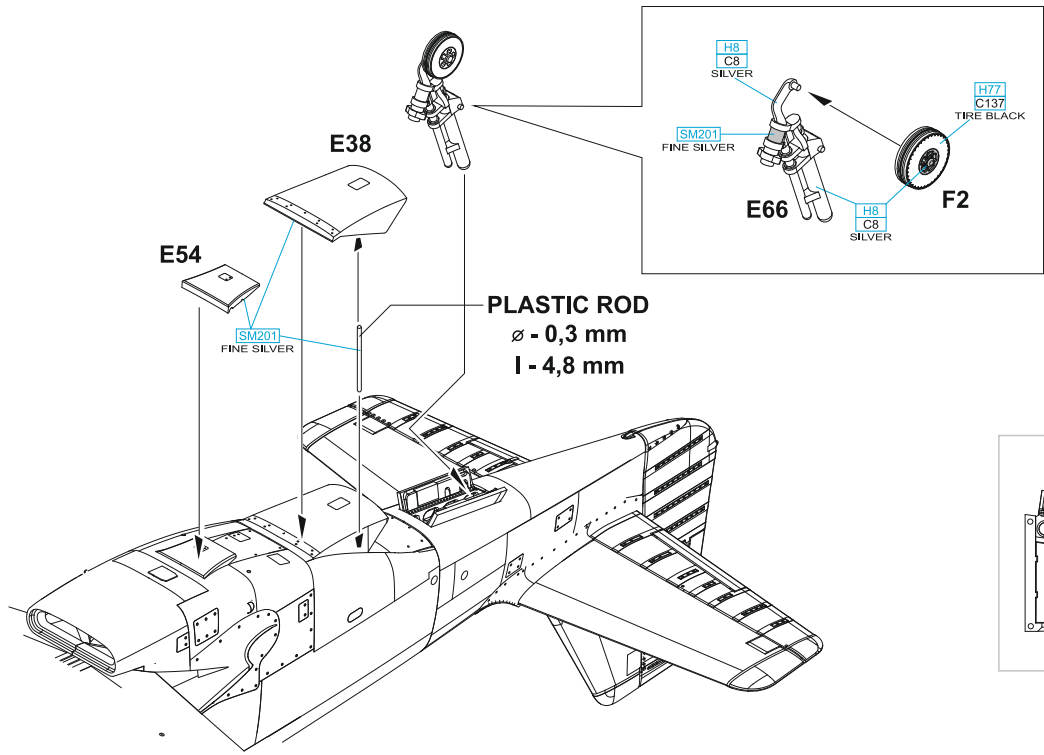

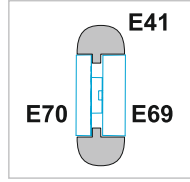
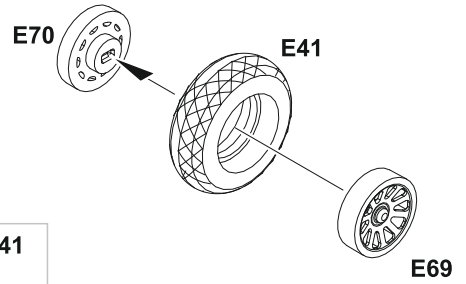
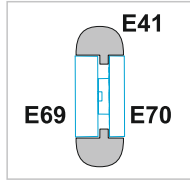
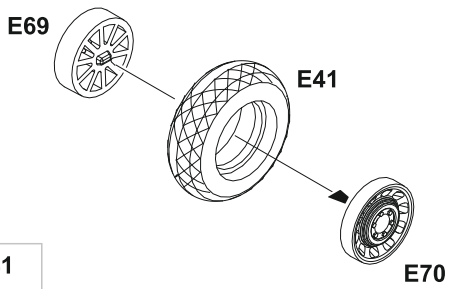

E port

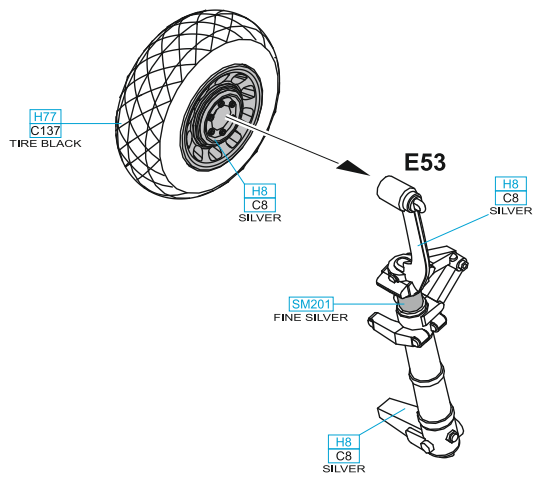

F starboard

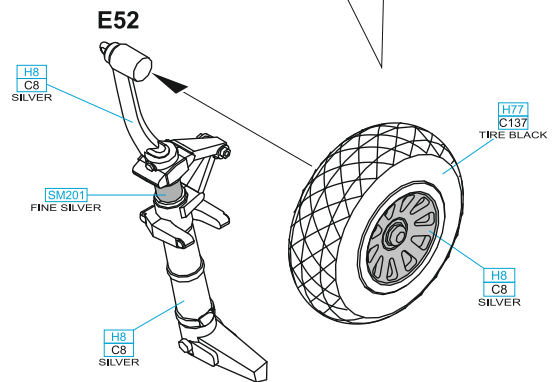

G

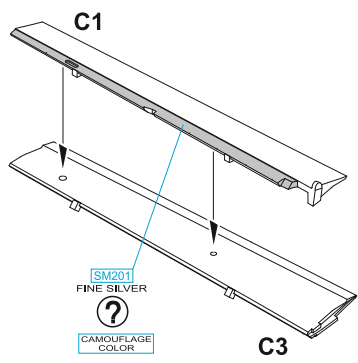

CAMOUFLAGE COLOR - MARKING **A** ONLY

H

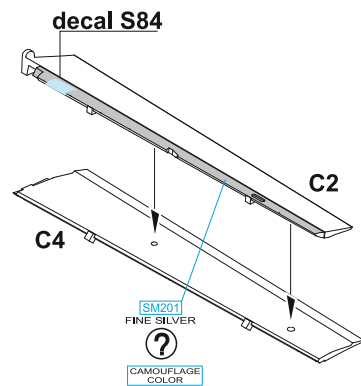

CAMOUFLAGE COLOR - MARKING **A** ONLY

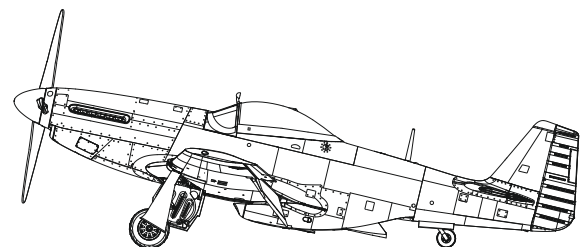
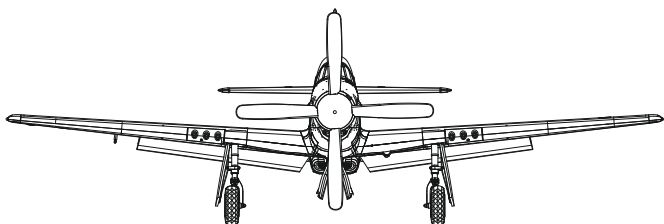

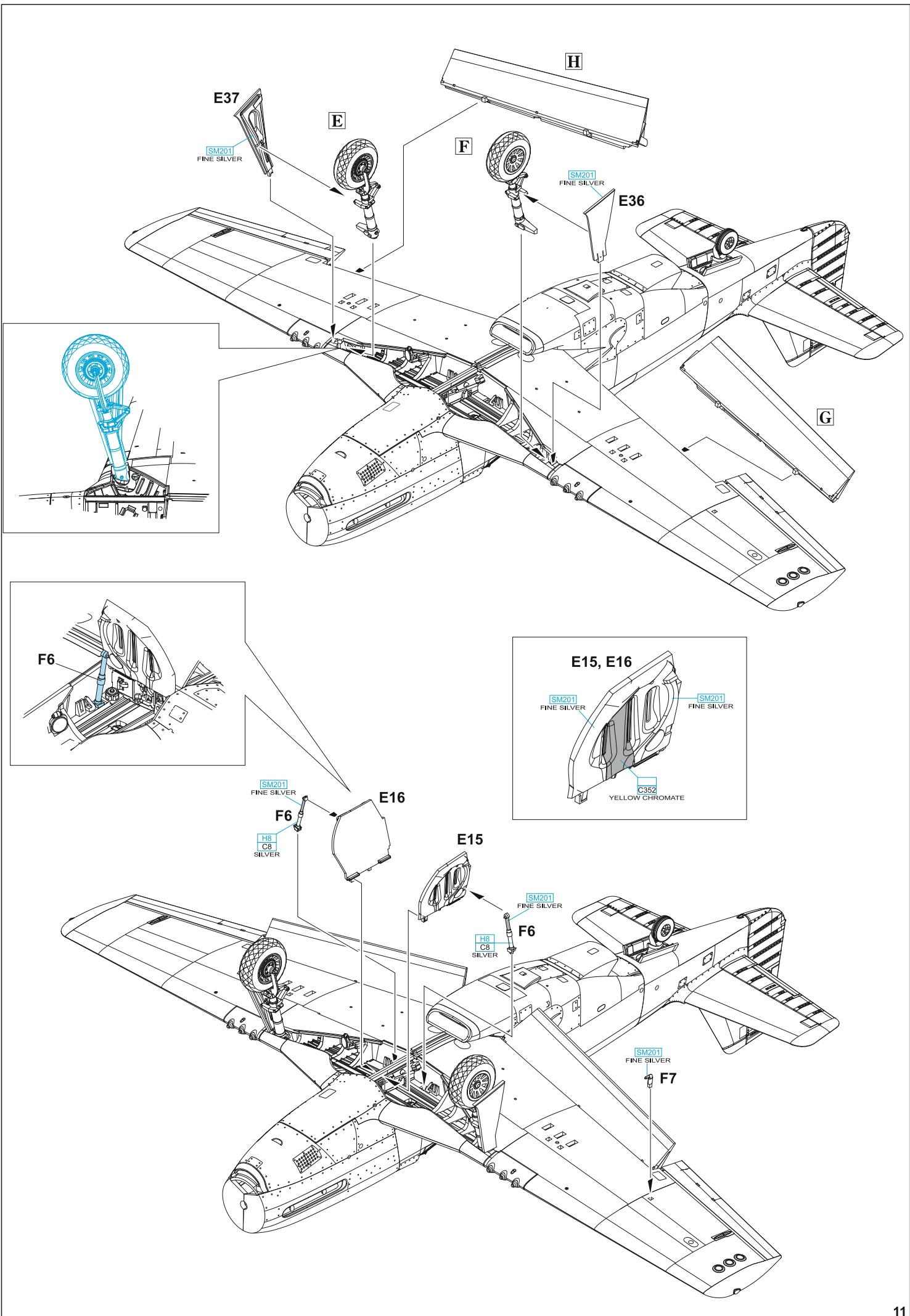

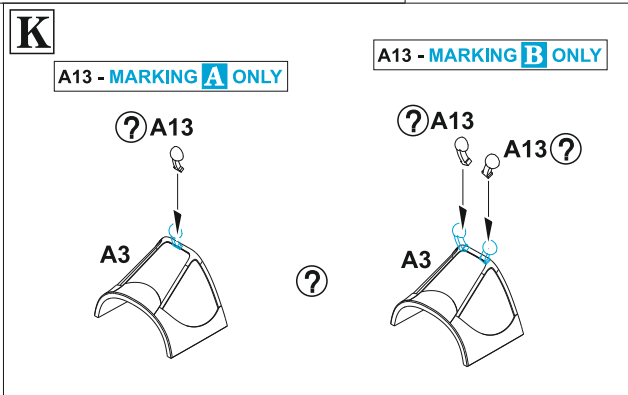
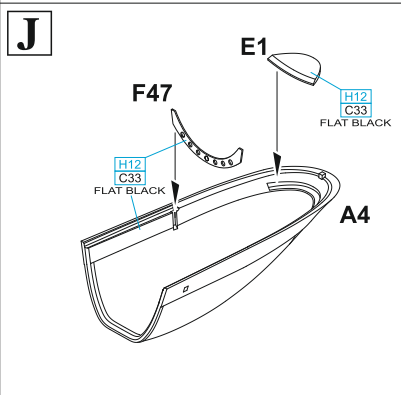
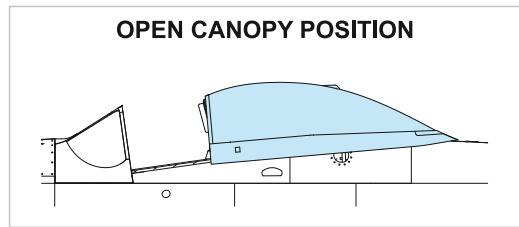
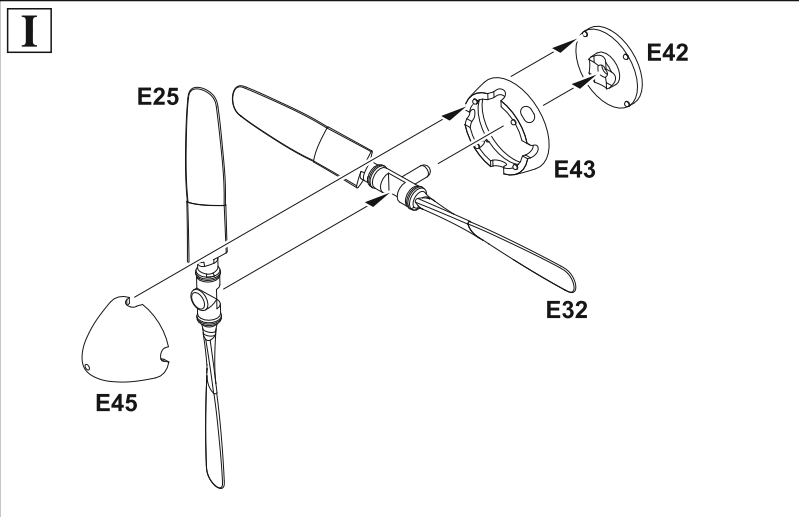

E24, E55 - MARKINGS **A B D**
E67 - MARKING **C**

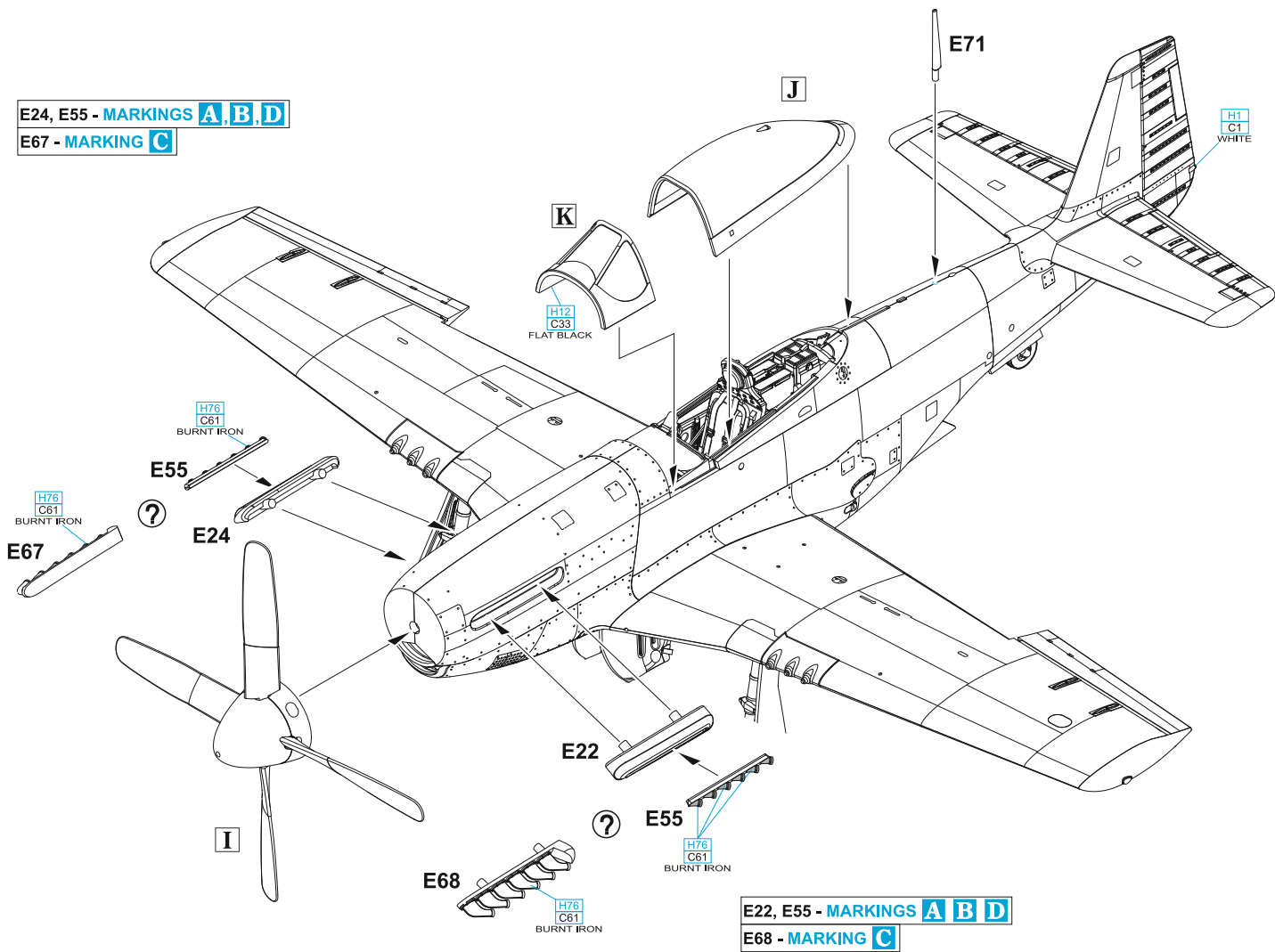

L 2 pcs.

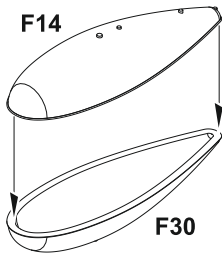

2 pcs.

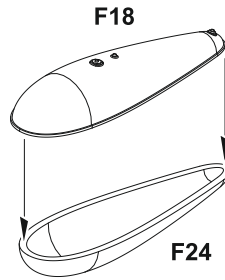

M 2 pcs.

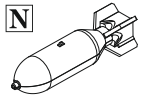
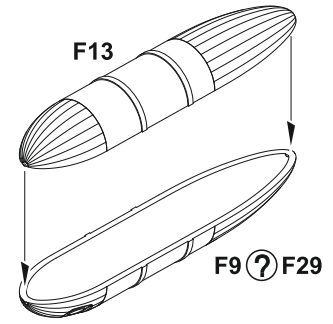

?

H53
C13
NEUTRAL GRAY

H8
C8
SILVER

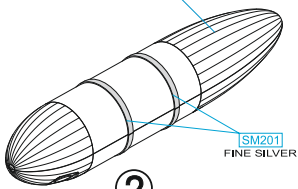

M

?

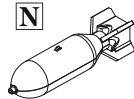

?

H53
C13
NEUTRAL GRAY

H8
C8
SILVER

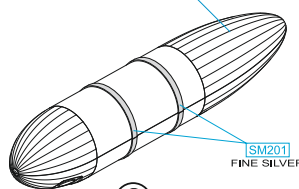

M

?

N

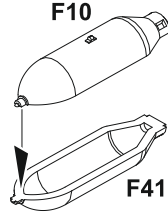

F32



F32

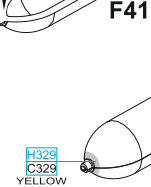

H52
C12
OLIVE DRAB

?

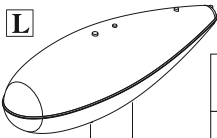

L

H12
C33
FLAT
BLACK - MARKINGS **A, C**

H8
C8
SILVER - MARKINGS **B, D**

H8
C8
SILVER

H12
C33
FLAT
BLACK

F20

?

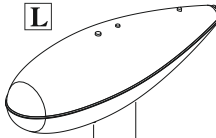

L

H12
C33
FLAT
BLACK



H8
C8
SILVER

F21

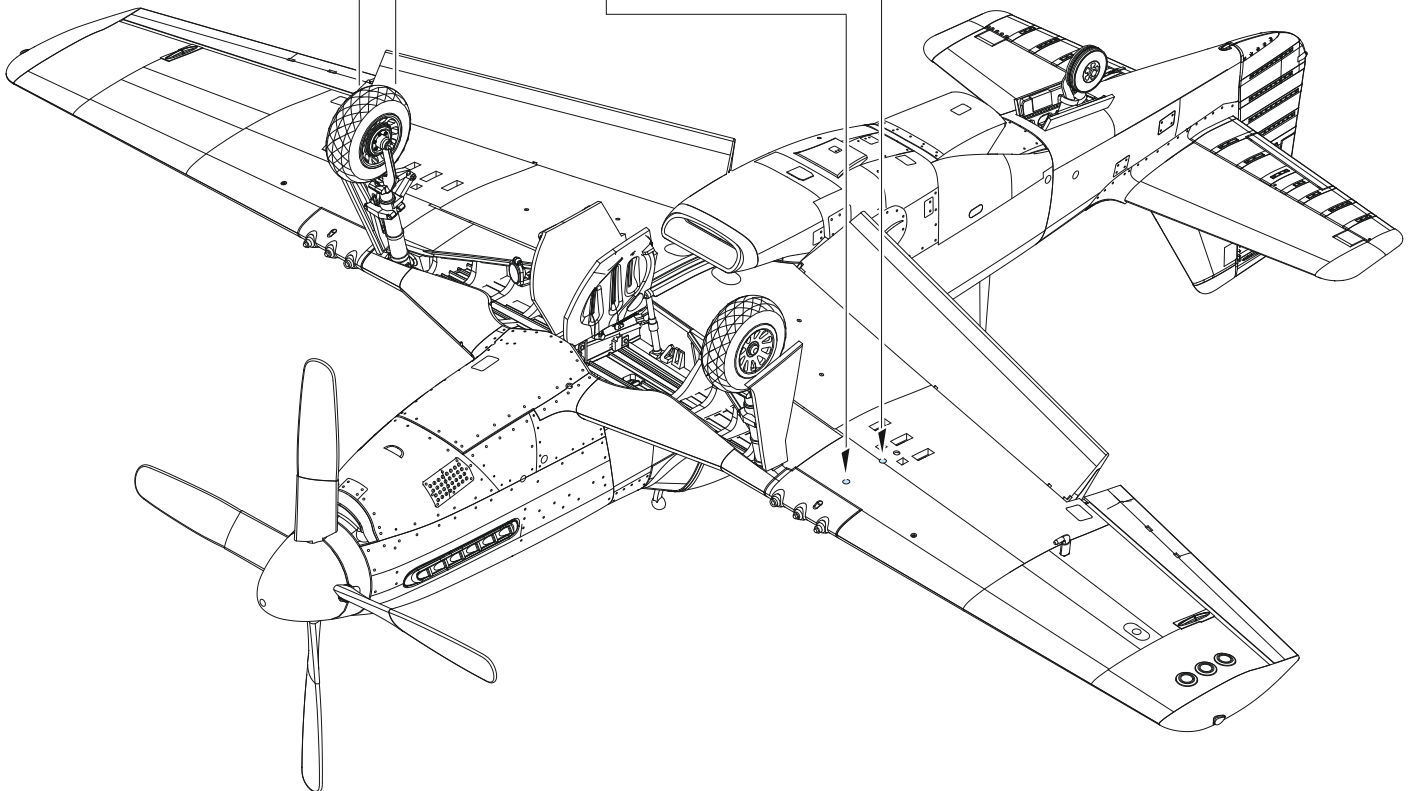
?



P-51D-5 ALUMINIUM LACQUER PAINTED AREAS

-  NATURAL METAL FINISH
-  ALUMINIUM LACQUER

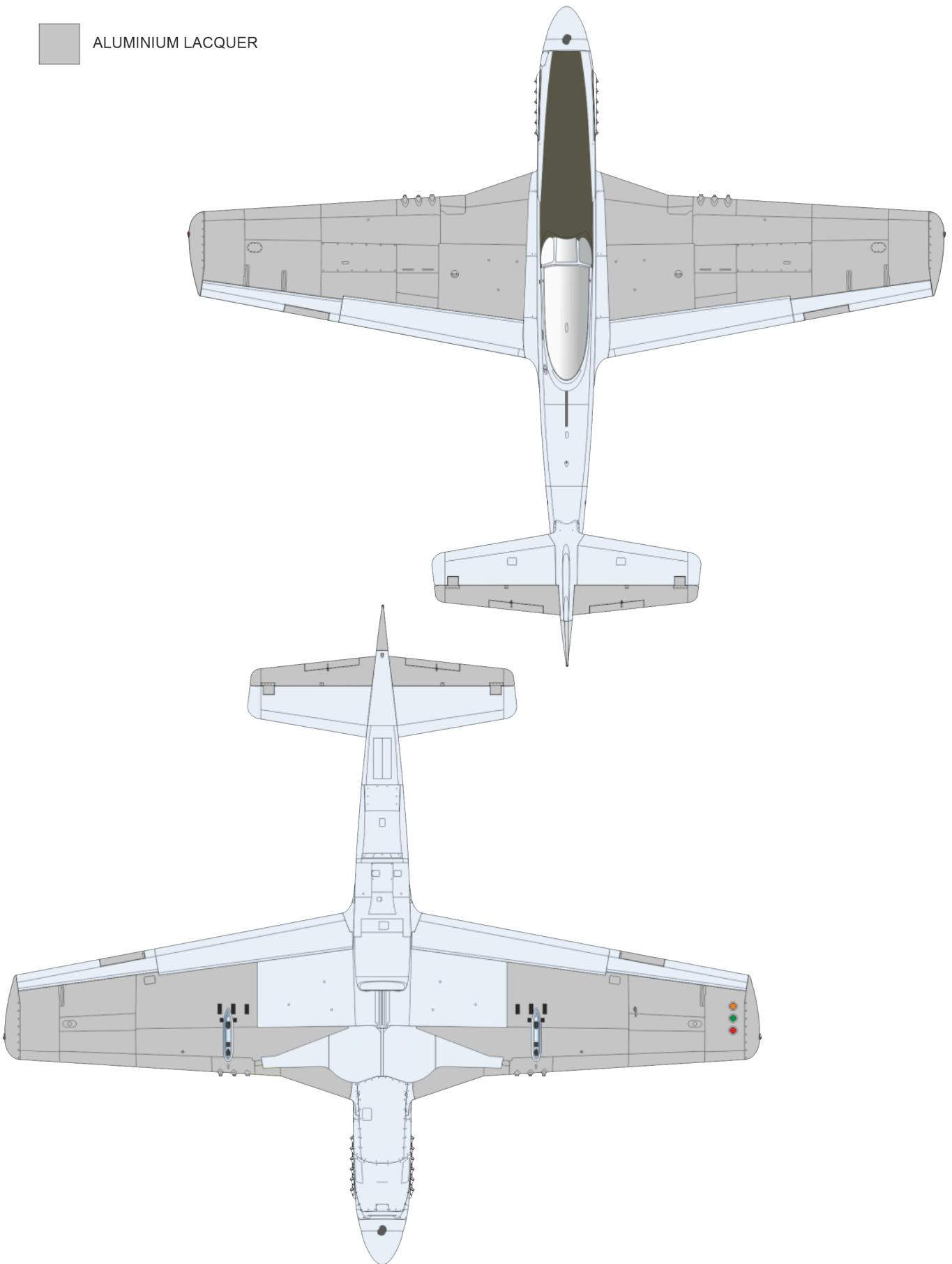

A 44-13691, Lt. Arval J. Roberson, 362nd FS, 357th FG, 8th AF, Leiston, United Kingdom, September 1944

Arval James Roberson was born on November 14, 1923, at Crown Point, Lake County, Indiana, USA. He joined the Army Reserves on June 15, 1942, and on May 20 of the same year as a rated pilot he was commissioned Second Lieutenant. He transferred to 362nd FS, 357th FG, where he flew 76 missions during his operation tour. He achieved six aerial victories confirmed plus one probable, the last two of them scored with the Mustang P-51D named Passion Wagon. Roberson later served in Korean War with 12th FBS, 18th FBG. He flew 100 combat missions there. During Vietnam War, he served as Liaison Officer to the VN JCS and he also flew 26 support missions with C-47s. He was promoted to Colonel on August 26, 1966, served as the last commander of the Otis AB and retired from Air Force on March 1, 1973. Arval Roberson passed away on December 7, 2007, (aged 84).

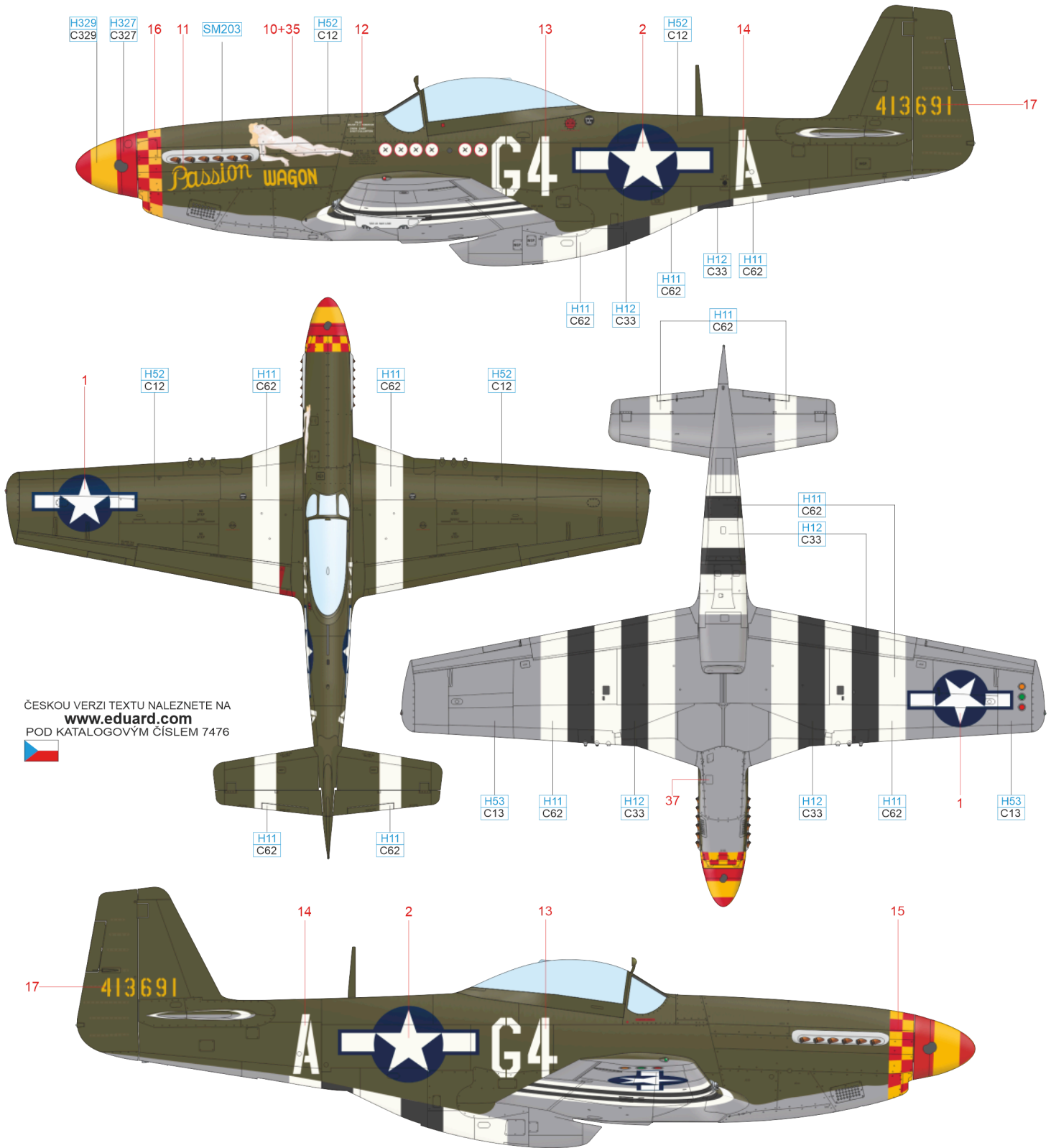

ČESKOU VERZI TEXTU NALEZNETE NA
www.eduard.com
 POD KATALOGOVÝM ČÍSLEM 7476



FLAT WHITE	H11	C62
SUPER IRON 2	SM203	
YELLOW	H329	C329
RED	H327	C327
NEUTRAL GRAY	H53	C13
OLIVE DRAB	H52	C12
FLAT BLACK	H12	C33

B 44-13737, Lt. Anton Wallace, 486th FS, 352nd FG, 8th AF, Bodney, UK, June 1944

The Mustang serial number 44-13737 was one of the first P-51Ds to be assigned to the 352nd FG in July 1944. This aircraft was fitted with the black code letters PZ-W and assigned to Lt. Anton J. Wallace, a member of the 486th FS, who had the inscription "Little Rebel" painted on the left side of the engine cowling, name previously carried by his P-47 and P-51B aircraft. The "Little Rebel" was initially flown in the original D-5 block state, i.e. without the additional dorsal fin of the vertical stabilizer. The additional installation of the fin occurred in the fall of 1944. In November 1944, after Wallace's second operational tour, Lt. Charles "Buck" Pattillo, took over the "Little Rebel" and decided to keep the name on the aircraft. However, the lettering was repainted. The white and black design was replaced by creamy one with a red outline. It is not known whether the change occurred while the aircraft was still in use by Wallace or after Pattillo took over.

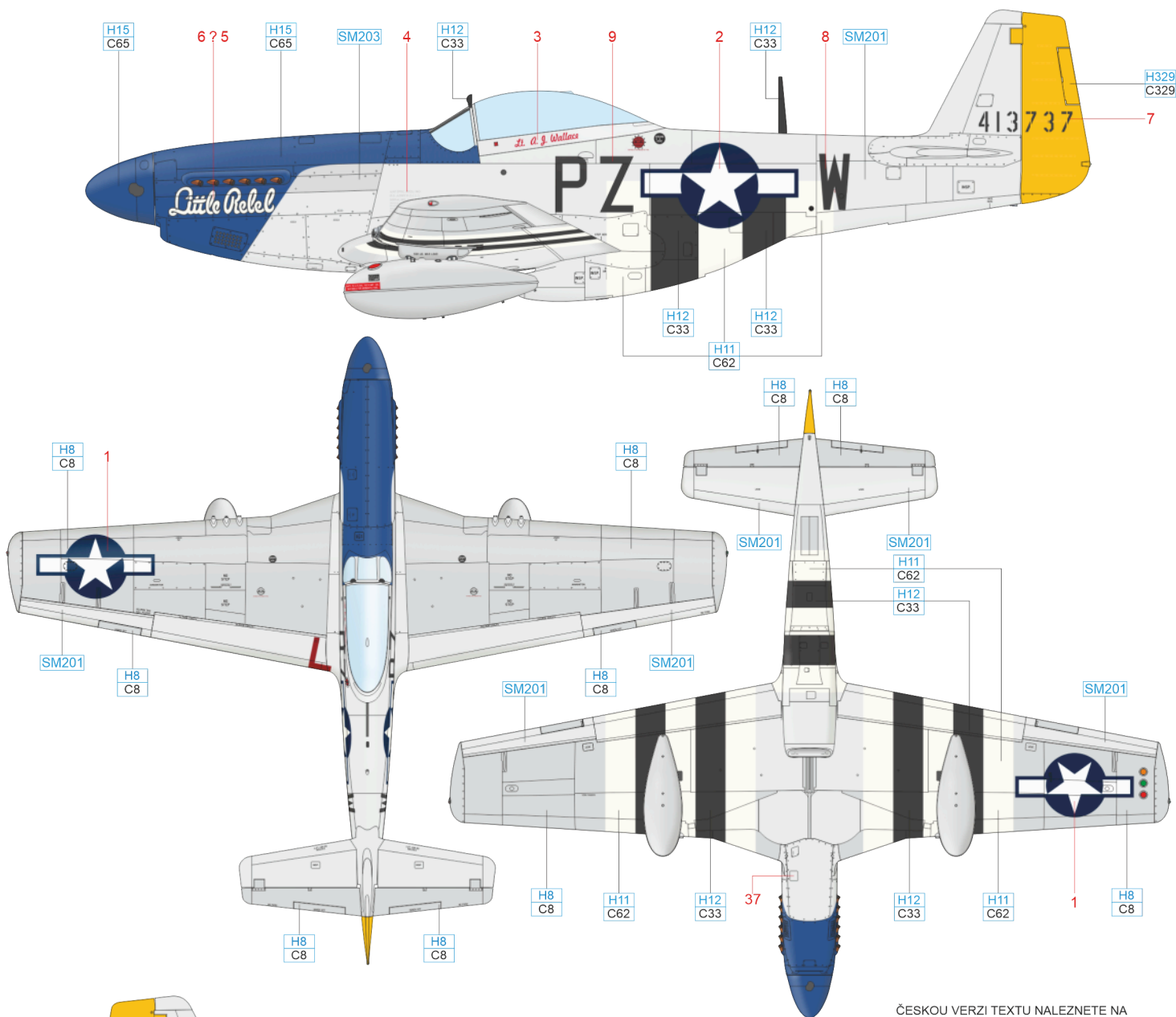

ČESKOU VERZI TEXTU NALEZNETE NA
www.eduard.com
 POD KATALOGOVÝM ČÍSLEM 7476



FLAT WHITE	H11 C62	SILVER	H8 C8	SUPER FINE SILVER 2	SM201	SUPER IRON 2	SM203	YELLOW	H329 C329	BRIGHT BLUE	H15 C65	FLAT BLACK	H12 C33
------------	---------	--------	-------	---------------------	-------	--------------	-------	--------	-----------	-------------	---------	------------	---------

C 44-13309, Maj. Evan McCall, 380th FS, 363rd FG, 9th AF, Maupertus airfield, Cherbourg, France, July 1944

Maj. Evan McCall named all his aircraft Fool's Paradise. Those with numbers I and II were P-39 Airacobras he flew at Hamilton Field, California. During the war, in addition to his role as a fighter pilot, he was also deployed with Patton's 3rd Armoured Division as a forward air navigator during the fighting in France until shortly before the Battle of the Bulge, when he returned to his unit and to flying. Although he did not become a fighter ace, he was one of the very experienced pilots and tested all American and most British single-seat fighter aircraft during his combat career. His Fool's Paradise IV already had the invasion stripes on the upper surfaces washed off in July. Instead, all that was left was the base Olive Drab paint, which had been eroded in many places by the process of washing the black and white stripes. There were also visible residue of the stripes. The same was true for the ridge area of the fuselage behind the canopy.

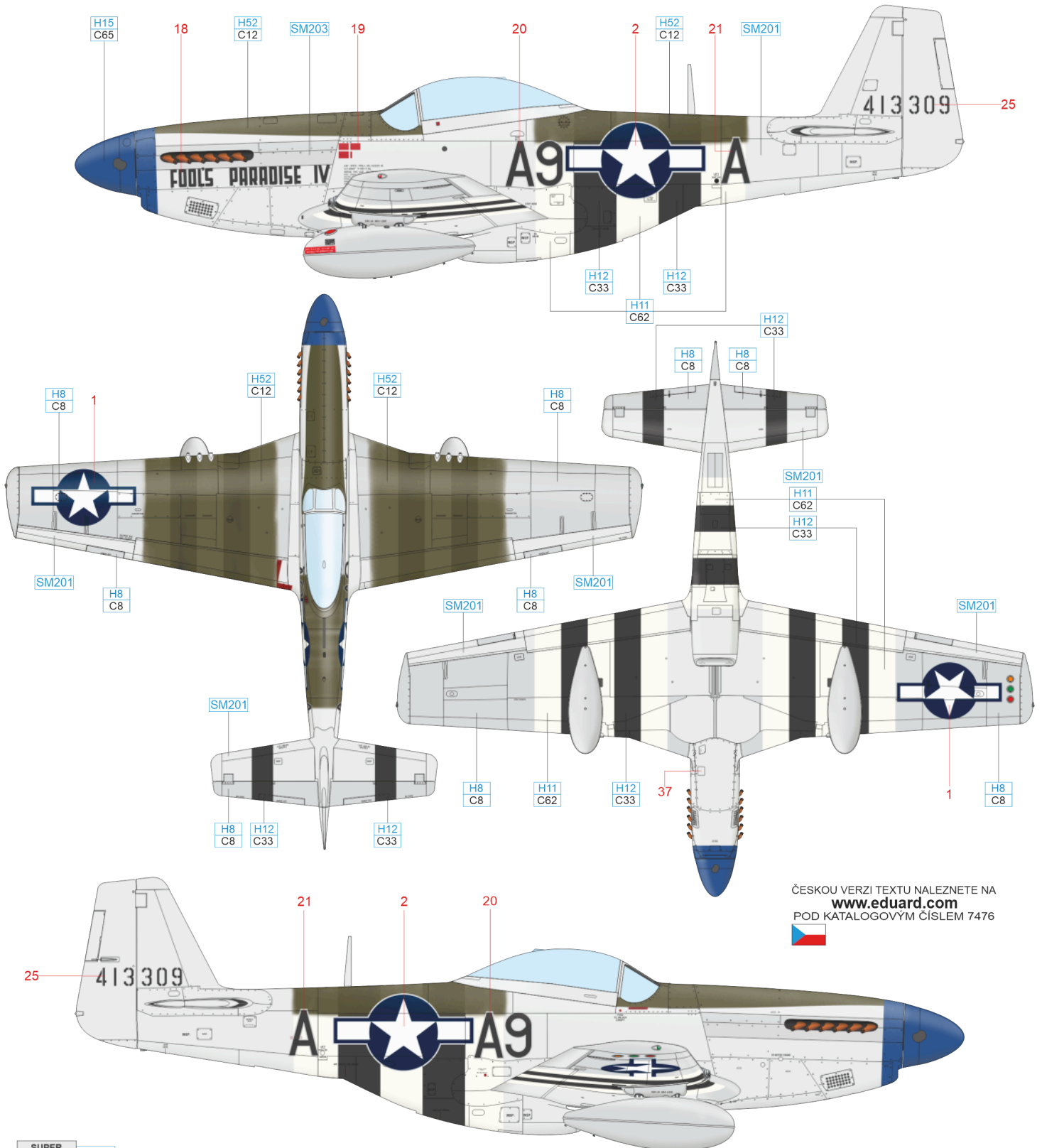

ČESKOU VERZI TEXTU NALEZNETE NA
www.eduard.com
 POD KATALOGOVÝM ČÍSLEM 7476



SUPER FINE SILVER 2 SM201

SUPER IRON 2 SM203

SILVER	H8 C8	FLAT WHITE	H11 C62	BRIGHT BLUE	H15 C65	OLIVE DRAB	H52 C12	FLAT BLACK	H12 C33
--------	-------	------------	---------	-------------	---------	------------	---------	------------	---------

eduard

D P-51D-5, 44-13494, Lt. Walter J. Goehausen Jr., 308th FS, 31st FG, 15th AF, San Severo, Italy, summer 1944

Walter John Goehausen was born on June 20, 1921, in St. Louis, Missouri. After his pilot training he was ordered to the 308th FS and while flying combat with it he scored ten kills of the enemy aircraft. After the previous deployment with VIII Fighter Command in Great Britain the 308th Fighter Squadron was sent to Africa within the 31st FG under the 12th AF command. Here this unit took part in the support of the landings in Sicily, then at Salerno and at Anzio. In Great Britain its pilots flew Spitfires Mk.V but during the Africa fighting they converted to the modern Spitfires Mk.VIII and Mk.IX. In April 1944 the 308th FS (together with the other 31st FG squadrons) was re-equipped with Mustangs which they flew within the 15th AF escorting the four-engine bombers over targets in occupied Europe and Germany as well. Besides the oblique red stripes, the markings of the 31st FG aircraft, his Mustang, nicknamed Miss Mimi II, also carried the yellow stripes on the wings and the tail surfaces introduced in March 1943 as the marking of the American fighters operating in the Mediterranean.

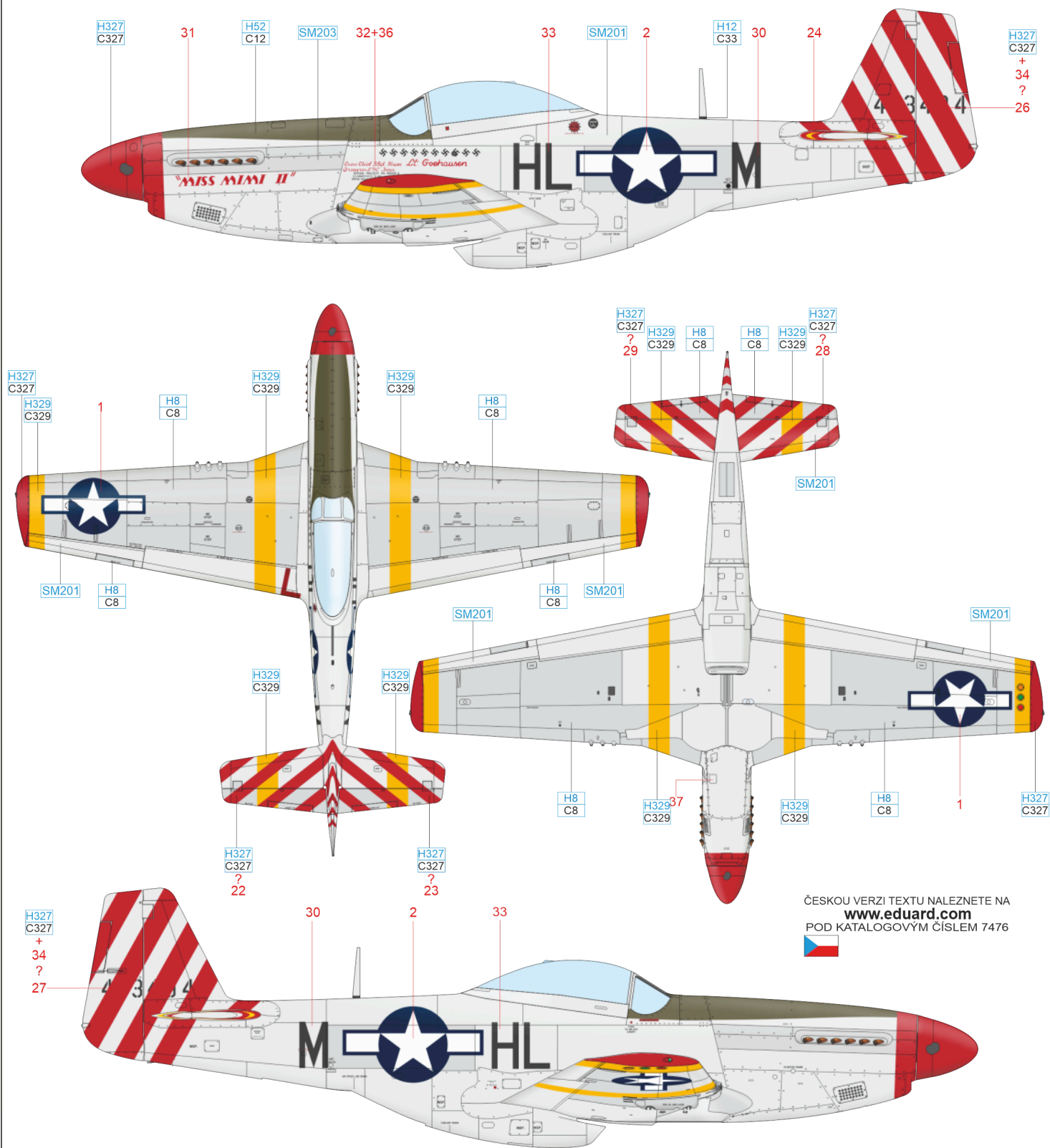

ČESKOU VERZI TEXTU NALEZNETE NA
www.eduard.com
 POD KATALOGOVÝM ČÍSLEM 7476

- SUPER FINE SILVER 2 SM201
- SUPER IRON 2 SM203
- SILVER H8 C8
- YELLOW H329 C329
- RED H327 C327
- OLIVE DRAB H52 C12
- FLAT BLACK H12 C33

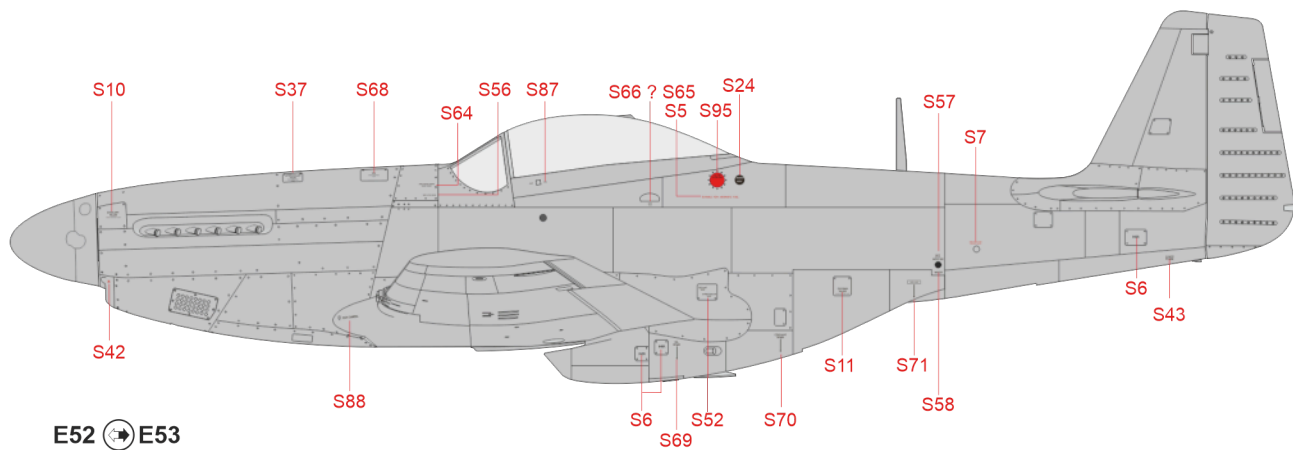

E52 → E53

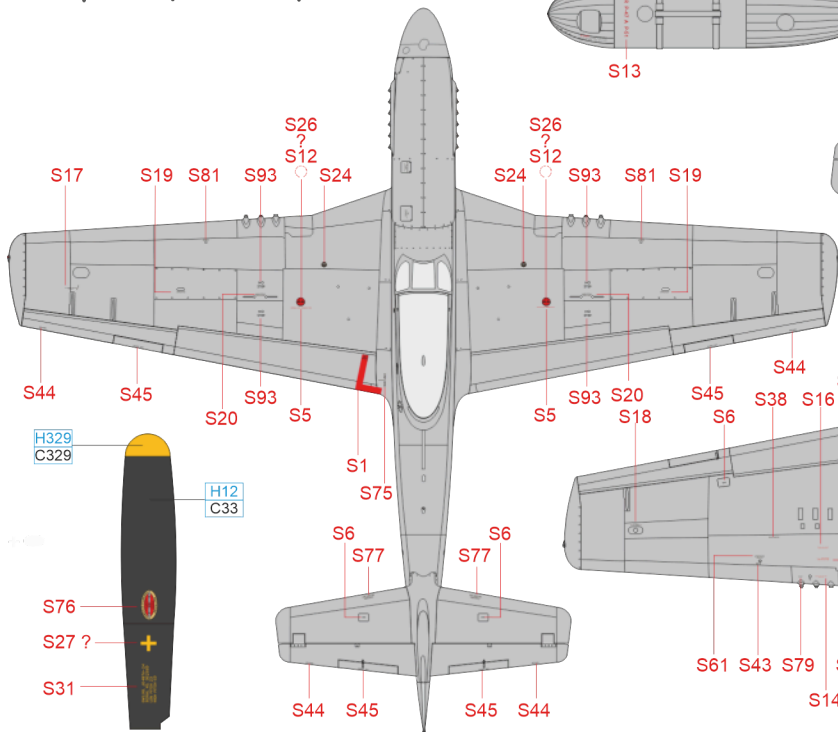
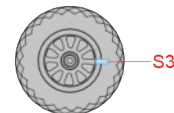
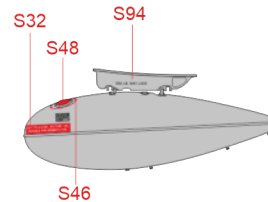
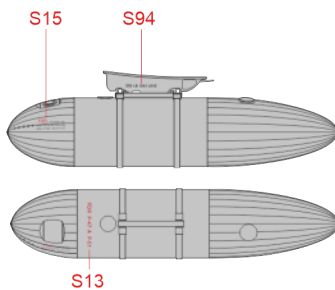
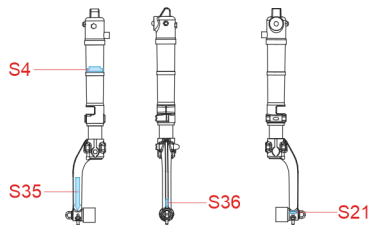

H329
C329

H12
C33

S76

S27 ?

S31

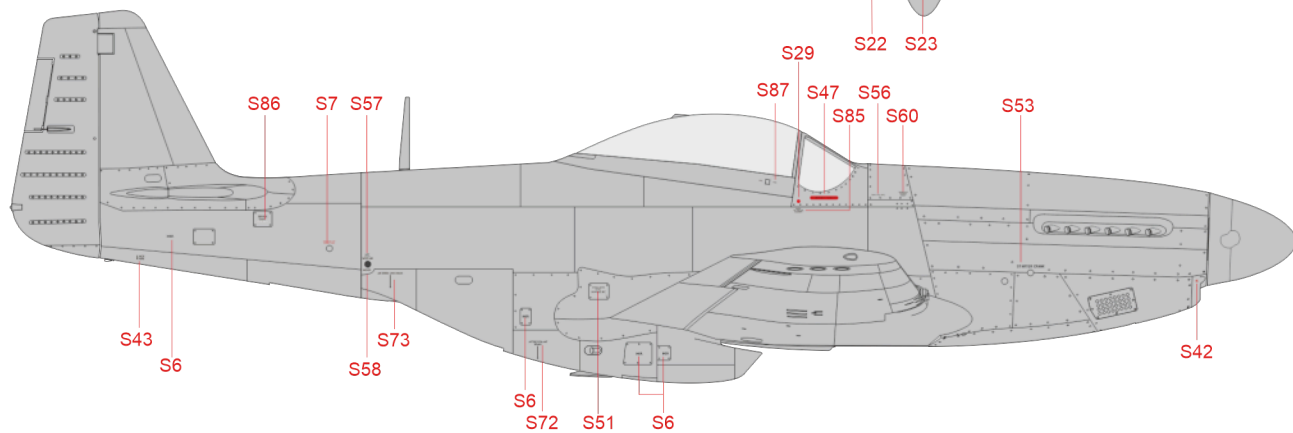
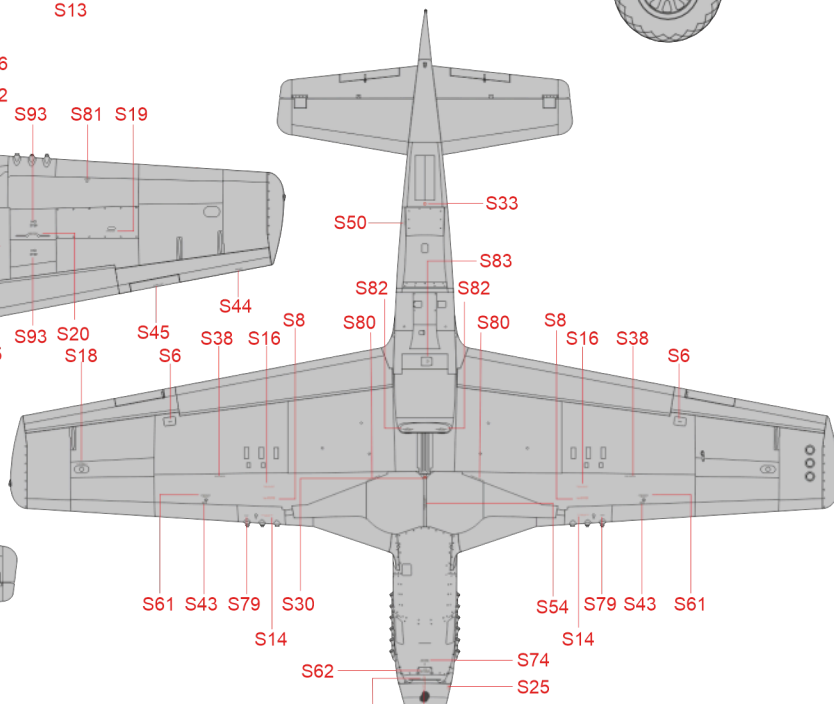

Eduard goodies for

P-51D-5 1/72

- SS826 P-51D seatbelts STEEL (PE-Set)
- 674012 P-51D-5 LööK (Brassin)
- 674015 P-51D-5 LööKplus (Brassin)
- 672358 P-51D exhaust stacks PRINT (Brassin)
- 672359 P-51D exhaust stacks w/ fairing PRINT (Brassin)
- 672360 P-51D wheel bay PRINT (Brassin)
- 672361 P-51D Hamilton Standard propeller PRINT (Brassin)
- 672363 P-51D-5 cockpit PRINT (Brassin)
- 672366 P-51D wheels diamond tread (Brassin)
- 672367 P-51D wheels oval tread (Brassin)
- 672368 P-51D wheels cross tread (Brassin)
- 672369 P-51D wheels block tread (Brassin)
- 672370 P-51D wheels diamond tread 2 (Brassin)
- 672371 P-51D wheels block tread 2 (Brassin)
- 672372 P-51D seat PRINT (Brassin)
- 672373 P-51D 75gal drop tanks PRINT (Brassin)
- 672374 P-51D 108gal paper drop tanks PRINT (Brassin)
- 672375 P-51D 110gal fuel tanks PRINT (Brassin)
- 672376 P-51D 165gal fuel tanks PRINT (Brassin)
- 672377 P-51D gun sights PRINT (Brassin)
- 672379 P-51D gun bays PRINT (Brassin)
- 672384 P-51D undercarriage legs PRINT (Brassin)
- 672389 P-51D engine PRINT (Brassin)
- D72050 P-51D stencils (Decal Set)
- D72051 P-51D US national insignia (Decal Set)
- D72053 P-51D-5 „8th AF“ (Decal Set)
- CX664 P-51D US national insignia (Mask)
- CX665 P-51D surface panels (Mask)
- CX673 P-51D (Mask)

