

**CZ**

## Mirage F.1 Duo Pack - Single Seaters

Mirage F.1 vděčí za svůj vznik soukromé iniciativě firmy Dassault. Ta sice pracovala z iniciativy Armée de l'Air na několika projektech stíhacích letounů, které měly dát Armée de l'Air nový bojový letoun schopný přepadového stíhání a zároveň taktických útoků s klasickou i atomovou výzbrojí (šlo o možné nástupce Mirage III a byly to projekty označené Mirage IIIT, Mirage III F, Mirage G a G8). Armée de l'Air si vybrala nejslibnější projekt Mirage G8 s měnitelnou geometrií křídla. Protože se očekával dlouhý vývoj, rozhodlo se velení Armée de l'Air pro dočasné zavedení Mirage IIIF než bude k dispozici nový Mirage G8A. Objednalo proto stavbu dvou prototypů F.2 a F.3. s motory JTF10 Dassault ale postavil na své náklady ještě jeden prototyp s menšími rozměry a motorem Atar 9K. Tento prototyp, jenž vzlétl poprvé 23. prosince 1966 byl vybrán a sériové stroje byly zavedeny do výzbroje Armée de l'Air jako jednomístné stíhačky Mirage F.1C a dvoumístné cvičné stíhačky Mirage F.1B.

V průběhu služby byla část strojů Mirage F.1 modifikována montáží tankovacího návstavce na verzi Mirage F.1C-200. Francouzské letectvo také používalo dvě průzkumné verze, Mirage F.1CR a z Mirage F.1-200 přestavované Mirage F.1CT. Armée de l'Air dostalo celkem 246 kusů všech verzí Mirage F.1. Firma Dassault zkusila nabídnout upravenou Mirage F.1E (E jako European) s výkonnějším motorem Belgii, Dánsku, Nizozemí a Norsku jako náhradu za F-104. Tyto státy daly přednost F-16 a tak Mirage F.1E zůstala jen v prototypu. I tak se ale Mirage F.1 stala úspěšným exportním artiklem. V Evropě ji zařadilo do výzbroje Španělsko a Řecko. V Jižní Americe se jediným uživatelem stal Ekvádor, zato v Africe a Asii byly Mirage F.1 zařazeny do výzbroje Gabonu, Jižní Afriky, Maroka, Libye, Iránu, Iráku, Jordánska, Kataru a Kuvajtu. Mirage F.1 se díky tomu zapojily do mnoha konfliktů po celém světě, od soubojů bez výstřelů řeckých stíhaček s tureckými protivníky, přes francouzské akce v Čadu, ekvádorské pohraniční konflikty s Peru, boje jihoafrických Mirage proti kubánským letounům z Angoly až po účast ve válce proti Iráku, kde létaly Mirage F.1 na obou stranách. I v současnosti má Mirage F.1 ve výzbroji několik států.

rozpětí: 8,40 m, délka: 15,30 m, max. rychlost: Mach 2,2, dolet 3 300 km, dostup: 20 000 m, výzbroj: 2x kanon DEFA 553 ráže 30 mm a kombinace bomb, raket, průzkumných kontejnerů, předávných nádrží a dalšího vybavení.

**EN**

The Mirage F.1C came about as a private venture by the French Dassault company while it had been engaged in a project designed to fulfil the future needs of the French Air Force (Armée de l'Air) for a modern jet aircraft capable of carrying out interception and tactical attack roles carrying conventional or nuclear armament. A variety of designs were put forward in order to replace the outstanding Mirage III family which were currently filling this role and these were originally designed the Mirage IIIT, Mirage IIIF, Mirage G and Mirage G8. The Armée de l'Air chose the most promising of these designs which was the Mirage G8 with a variable-sweep wing but as the military expected a prolonged development of this advanced (for the day) technology they also decided to go ahead with the simpler Mirage IIIF which could enter service sooner and help bridge the gap before the new G8A could be finished. Two prototypes of the IIIF designated F.2 and F.3 were ordered and these were to be powered by a JTF10 engine.

On top of these government contracts Dassault also decided to go ahead with their own simpler private venture design which featured a smaller airframe powered by an Atar 9K power plant and when the other two more advanced aircraft were cancelled by the French government it was the private venture design which was eventually chosen for military service as the Mirage F.1, featuring a small shoulder mounted wing and conventional tailplane.

The first flight of the Mirage F.1 took place on 23rd December 1966 and production aircraft entered service with the Armée de l'Air as the F.1C single-seater fighter and F.1B two-seater trainer versions. During their service with France a number of these aircraft were upgraded by fitting of IFR probes which resulted in the designation F-1C-200. The Armée de l'Air also flew dedicated reconnaissance and a ground-attack versions of the Mirage F.1 designated respectively as the F.1CR and CT, the latter being converted from the earlier F.1-200 airframes. A total of 246 Mirage F.1's of all versions served with the French and Dassault also tried to offer the aircraft as the F.1E (E for European) version with a more powerful engine to Belgium, Denmark, the Netherlands and Norway as a replacement for their F-104 Starfighter's but these countries chose the F-16 Fighting Falcon instead and the F.1E remained only as a prototype. Nevertheless two other European NATO members did fly the Mirage F.1 with Greece (F.1CG) and Spain (F.1CE, EE & BE) ordering the type and it was also exported successfully further afield. In South America Mirage F.1's were ordered by Ecuador (F.1JA and JE two seaters) for the Fuerza Aerea Ecuatoriana while in Africa and Asia the Mirage F.1 proved especially popular, serving with the air forces of Gabon, South Africa, Morocco, Libya, Iran, Iraq, Jordan, Qatar and Kuwait. Flying with these air forces this variant of the famous Mirage family saw combat action the world, including mock dogfights over the Aegean between Greek F.1's and Turkish fighters, French aircraft saw action over Chad, Libya, Afghanistan, Mali, Ivory Coast and even stood up against Iraqi Mirage F.1's during the 1st Gulf War, Ecuadorian F.1's were used in cross border skirmishes with Peru and South African Mirages also saw extensive action as a ground attack aircraft and fighter during the long Border War with Angola and Mozambique, often coming up against Cuban flown Soviet Mig 17, 21 and 23 jet fighters. Libyan F.1's also saw brief action during the Civil War of 2011 when several of them defected to Malta.

Although it is now quite an old aircraft the Mirage F.1 still sees frontline service with several countries including Libya which is bolstering its remaining fleet by buying some additional ex French aircraft, Gabon has bought six ex South African F.1AZ aircraft and Iran is believed to still fly some of the 24 ex Iraqi Mirage F.1BQ and EQ's which defected here during the Gulf War.

Wingspan: 8.40m, length: 15.30m, max. speed: Mach 2.2, range: 3,300km, ceiling: 20,000m, armament: 2x 30mm DEFA 553 cannon and various combinations of bombs, missiles, recce pods, fuel tanks and other equipment.

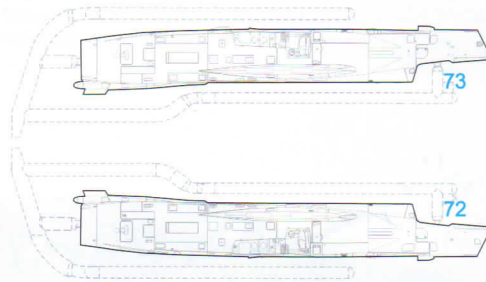
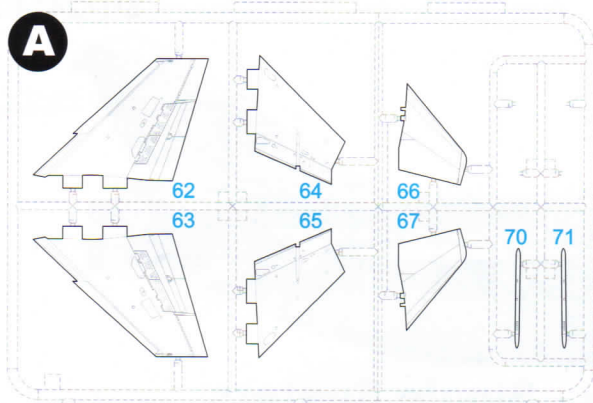

Parts not shown in this diagram are not to be used while you are building the model, or they may be used freely, in accordance with your references.

Ke stavbě modelu použijte díly znázorněné v této kresbě. Ostatní díly můžete případně použít podle vašich podkladů.

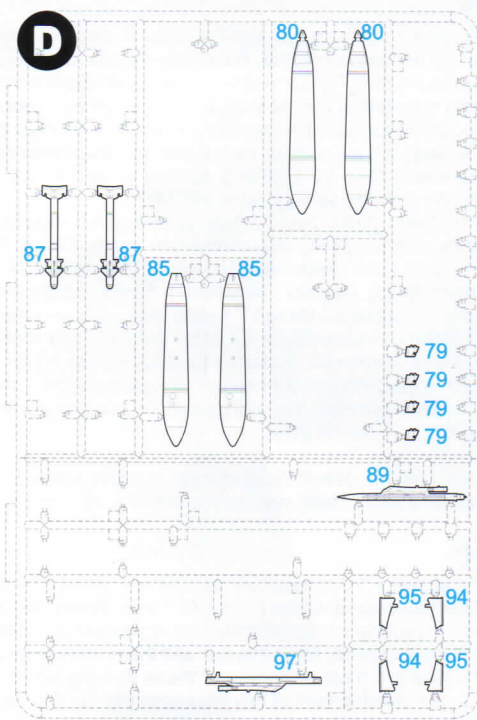
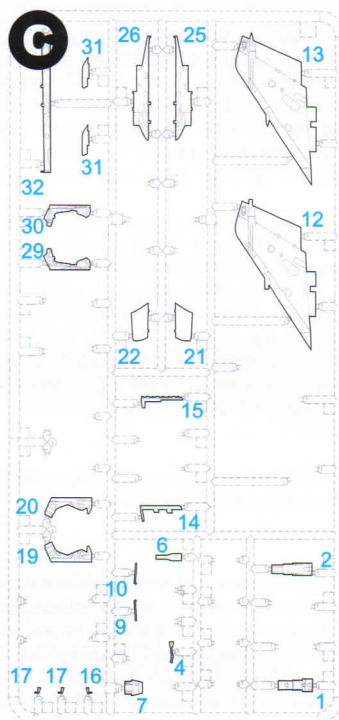
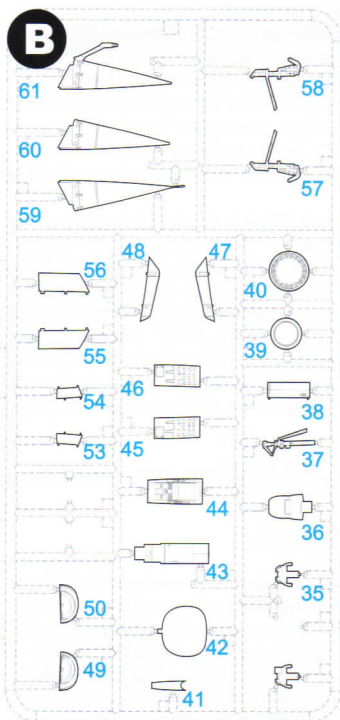

### Clear Parts

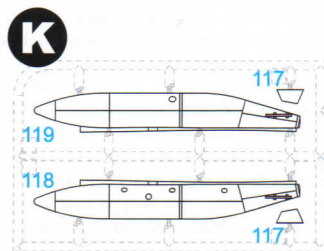
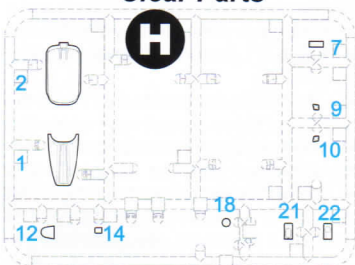

### PUR Parts

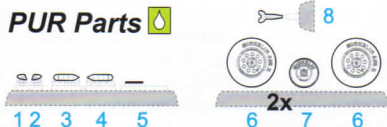

Barvy GUNZE / GUNZE Colour No.		
A	Černá / BLACK	H12/C33
B	Hnědočervená / LEATHER	M47/C41+H92/C49
C	Hliník / ALUMINIUM	H8/C8
D	Opálený kov / BURNT IRON	H76/C61
E	Žlutá / YELLOW	H4/C4
F	Červená / RED	H3/C3
G	Červená čirá / CLEAR RED	H90/C47
H	Modrá čirá / CLEAR BLUE	H93/C50
I	Barva pneu / TIRE BLACK	H77/C137
J	Olivová / OLIVE DRAB (2)	H78/C38
K	Světlá Olivová / OLIVE DRAB (1)	H52/C12
L	Chrom. stříbrná / CHROME SILVER	MC211
M	Tmavě šedá / DARK SEAGRAY	H75 / C25

### SYMBOLS



MOŽNOST VOLBY  
OPTIONAL  
NACH BELIEBEN  
OPTION



POUŽIT KYANOAKRYLÁTOVÉ LEPIDLO  
INSTANT CYANOACRYLATE GLUE  
ZYANOAKRYLATKLEBER  
ADHESIF CYANOACRYLAT



OHNOUT  
BEND  
BIEGEN  
COURBER



ZHOTOVIT NOVÉ  
SCRATCH BUILD  
FERTIGSTELLEN  
ACHEVER



ŘEZAT/VRTAT  
CUT OFF/DRILL  
ENTFERNEN  
DETACHER

GSI  
colours code

NATRÍT  
COLOUR  
FARBEN  
PEINDREN

**1a** instrument panel decals C,D&E  
Scheme A

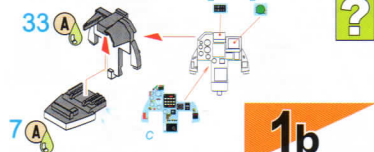

**1b** Schemes B,C  
instrument panel decals A&B

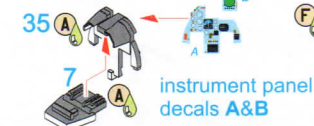

**2a** Scheme A

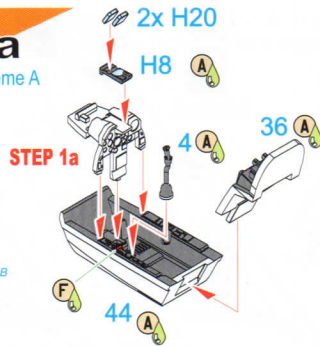

**2b** Schemes B,C

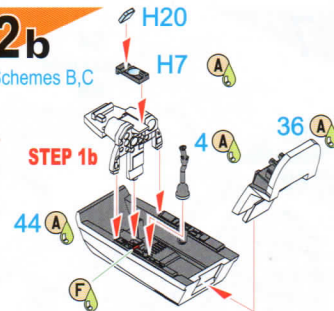

**3**

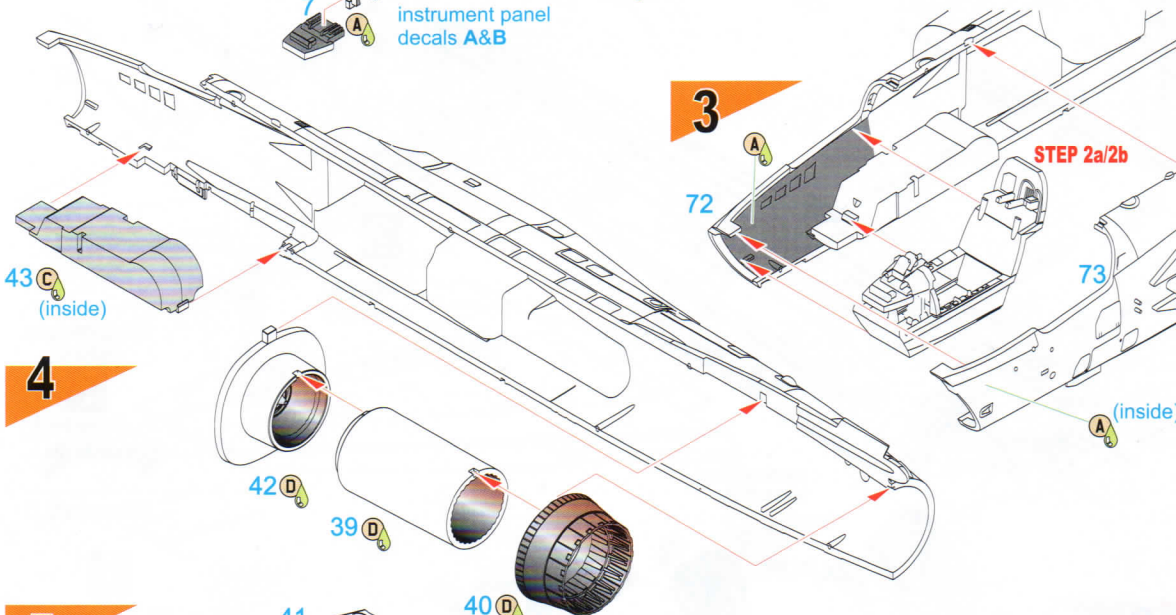

**4**

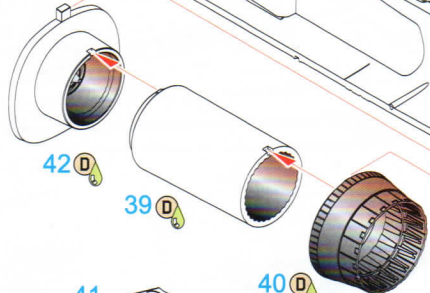

**5**

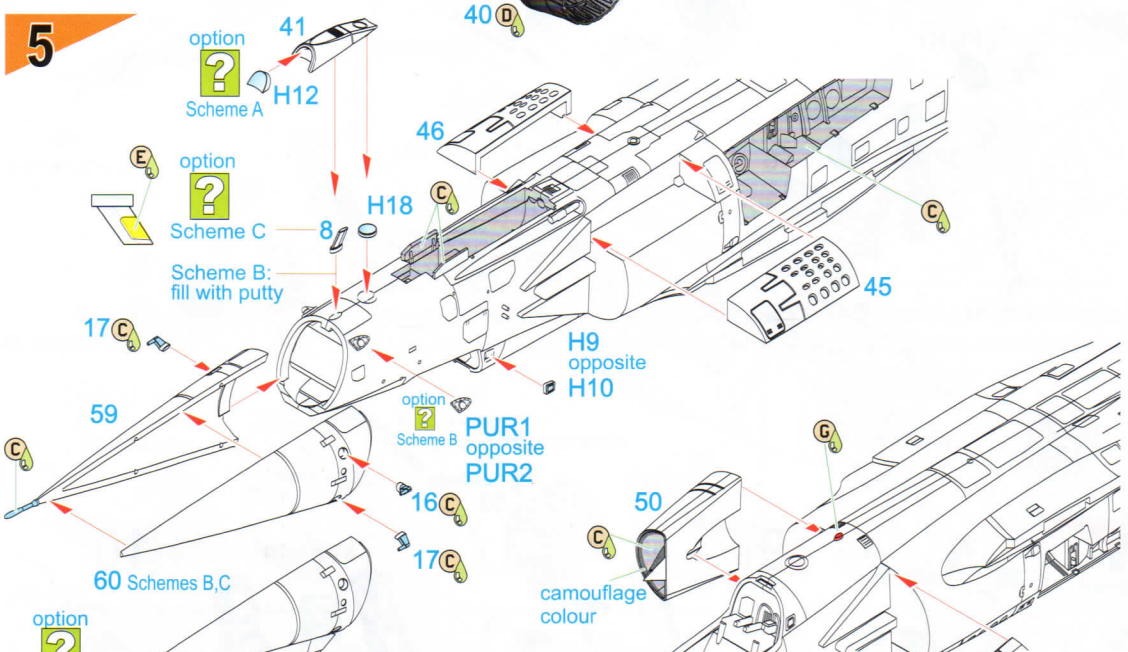

**6**

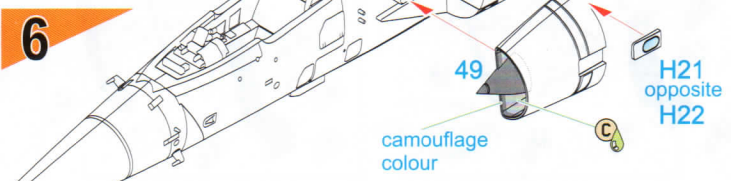

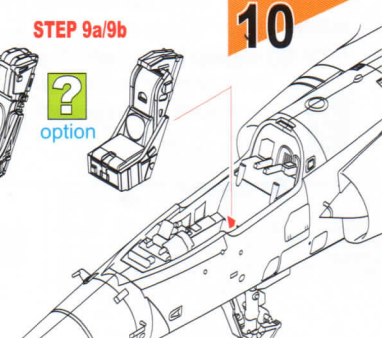
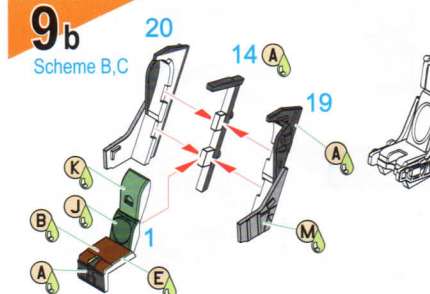
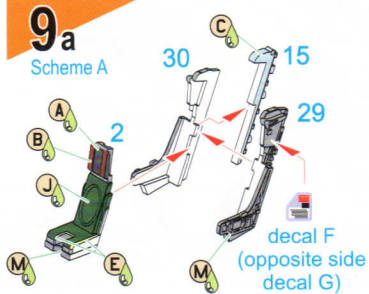
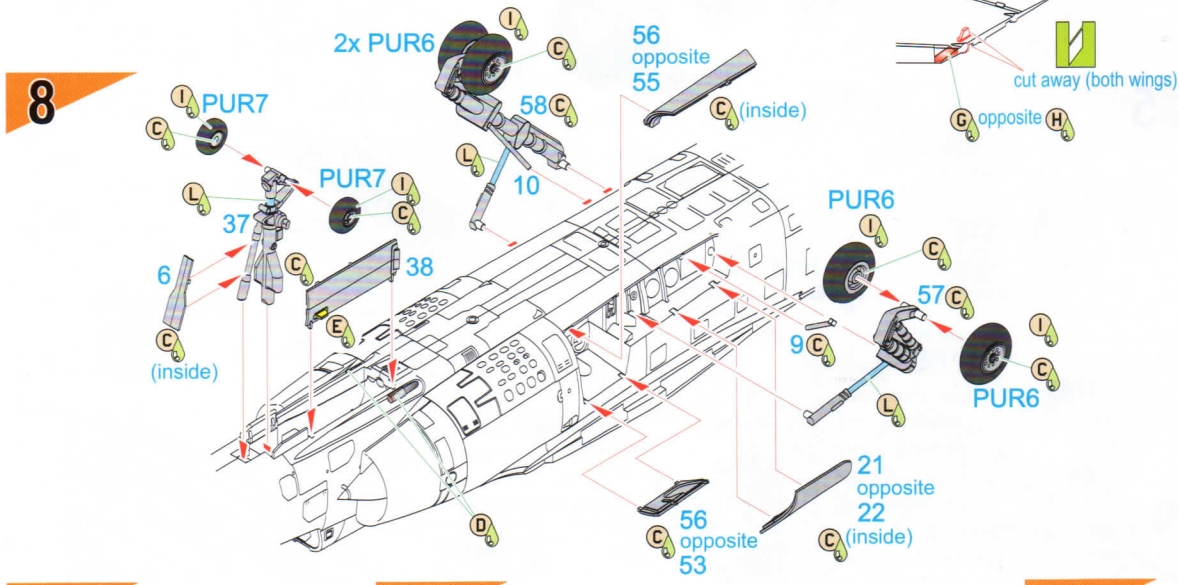
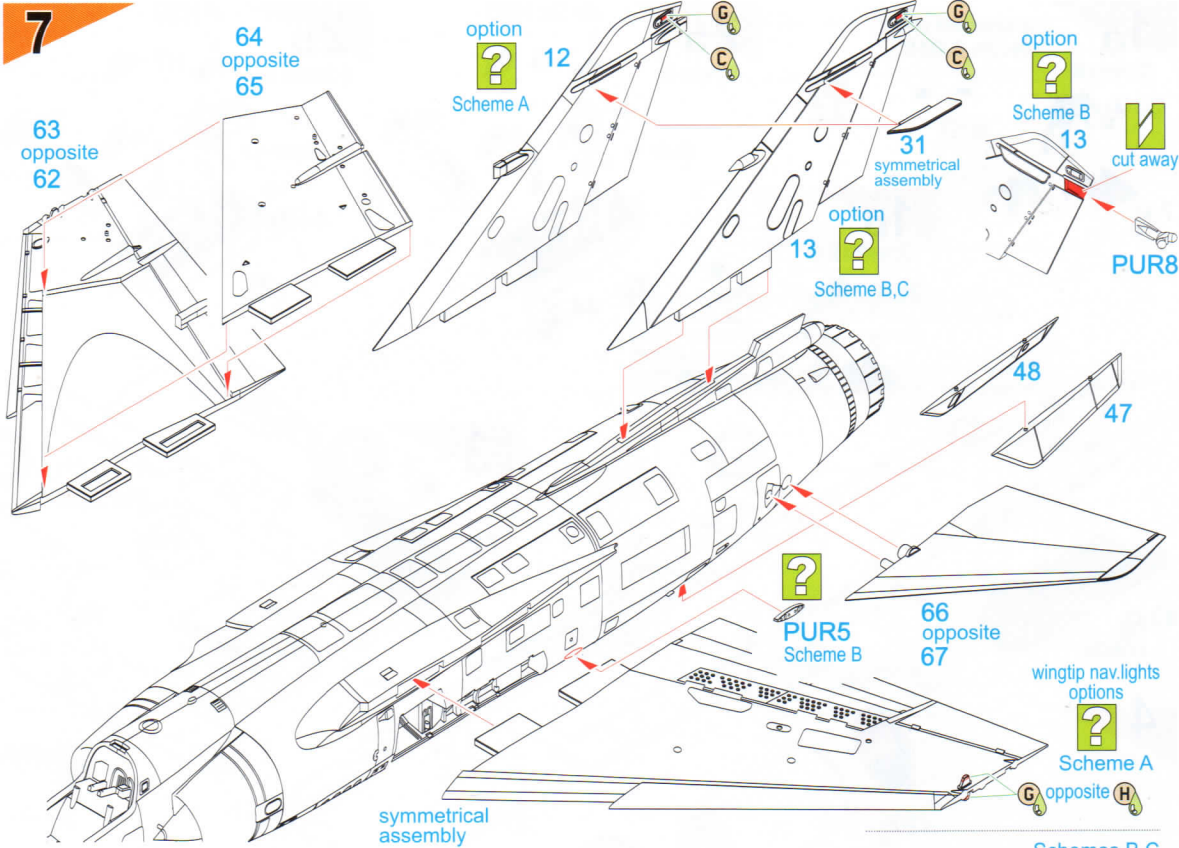

11

? Underwing stores scheme is optional, check your chosen camouflage version.

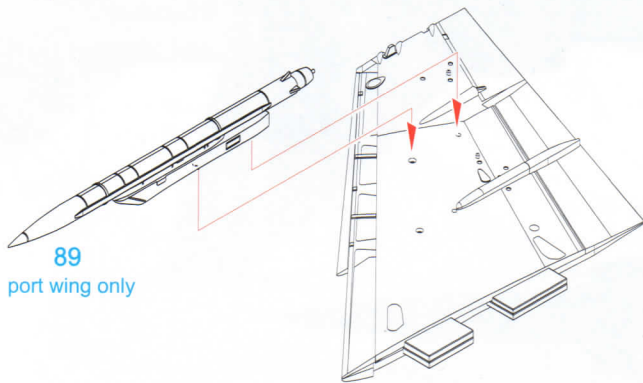
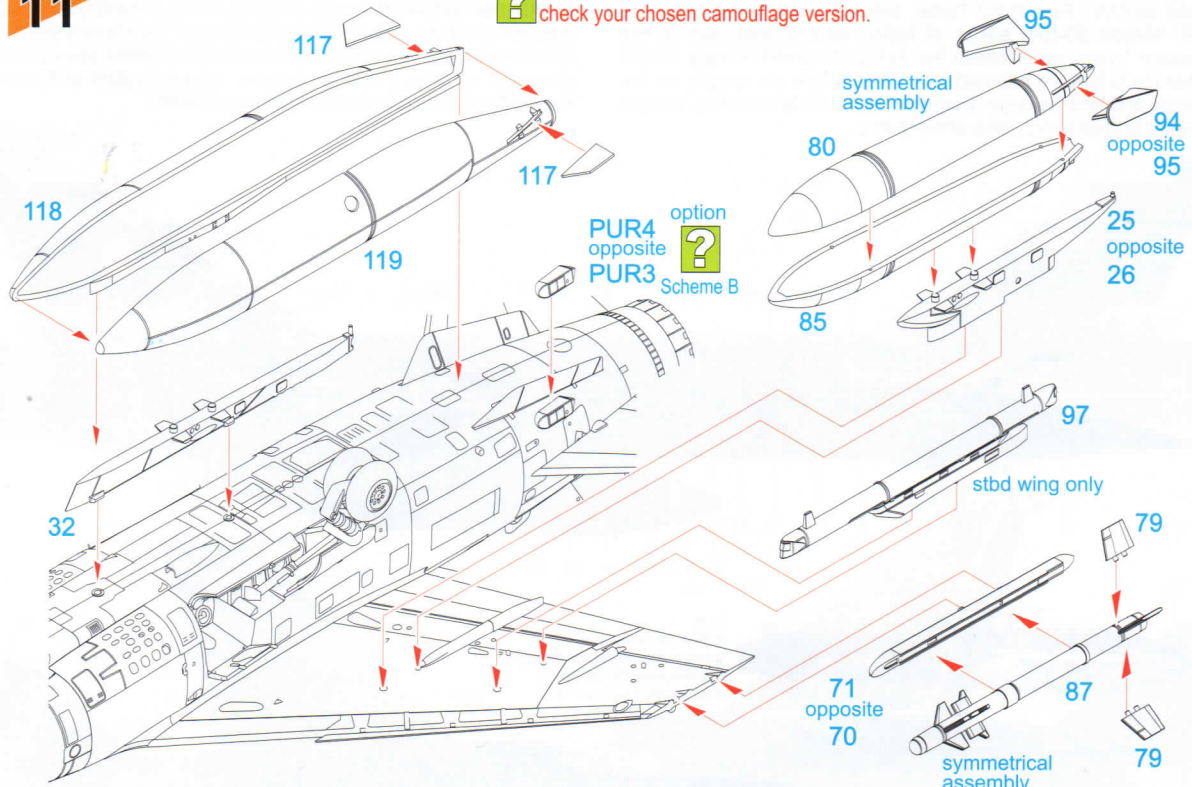

12

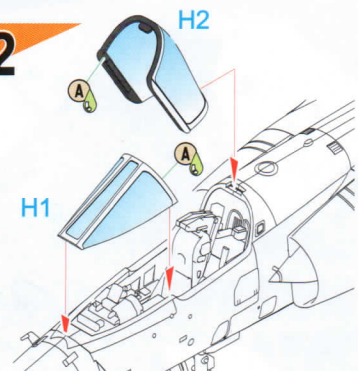

CMK resin sets to improve your Mirage F.1C, C-200, CR, CT and B kits. Available at your retailer or directly via our e-shop Specialhobby.eu  
 Pro vylepšení modelů Mirage F.1C, C-200, CR, CT a B můžete použít tyto CMK resinové sady. Žádejte u svého prodejce či přímo na e-shopu Specialhobby.eu

Q72 249  
Cyrano IV radar  
with pressurized casing

Q72 250  
Cyrano IV radar  
with uncovered scanner dish

Q72 252  
Afterburner unit  
and engine nozzle

Q72 253 MB Mk.4 seat

Q72 254 MB Mk.10 seat

Q72 311 Remora  
Radar Jammer

Q72 312 Sycomor  
Chaff/Flare Dispenser

Mirage F.1CT, 'Diana - Pristina Sunrise' 30-QH, c/n 244, 2/30 'Normandie Niemen', Base Aérienne BA132 Colmar - Meyenheim, Armée de l'Air / French Air Force. Between 19 May and 25 June 1999, Mirage 30-QH, based at Italian Istrana took part in the Operation Trident over Kosovo. For its flight back to France, a couple of Mirage CTs were adorned with Vargas-style pin up girls on the fuselage and had the large "Iraq-type" tanks under the belly. The pin ups were erased shortly after arrival home.

Mirage F.1CT, 'Diana - Pristina Sunrise' 30-QH, výr.č. 244, 2/30 'Normandie Niemen', základna BA132 Colmar - Meyenheim, Armée de l'Air (francouzské letectvo). Od 19.5. do 25.6. 1999 se stroj č.244 operující z italské základny Istrana účastnil Operace Trident nad územím Kosova. Pro návrat do Francie byl ozdoben vargasovskou pin-upkou na boku a nesl rozměrnou "iráckou" nádrž pod trupem. Kresba Diany byla odstraněna krátce po návratu.

**Scheme A**

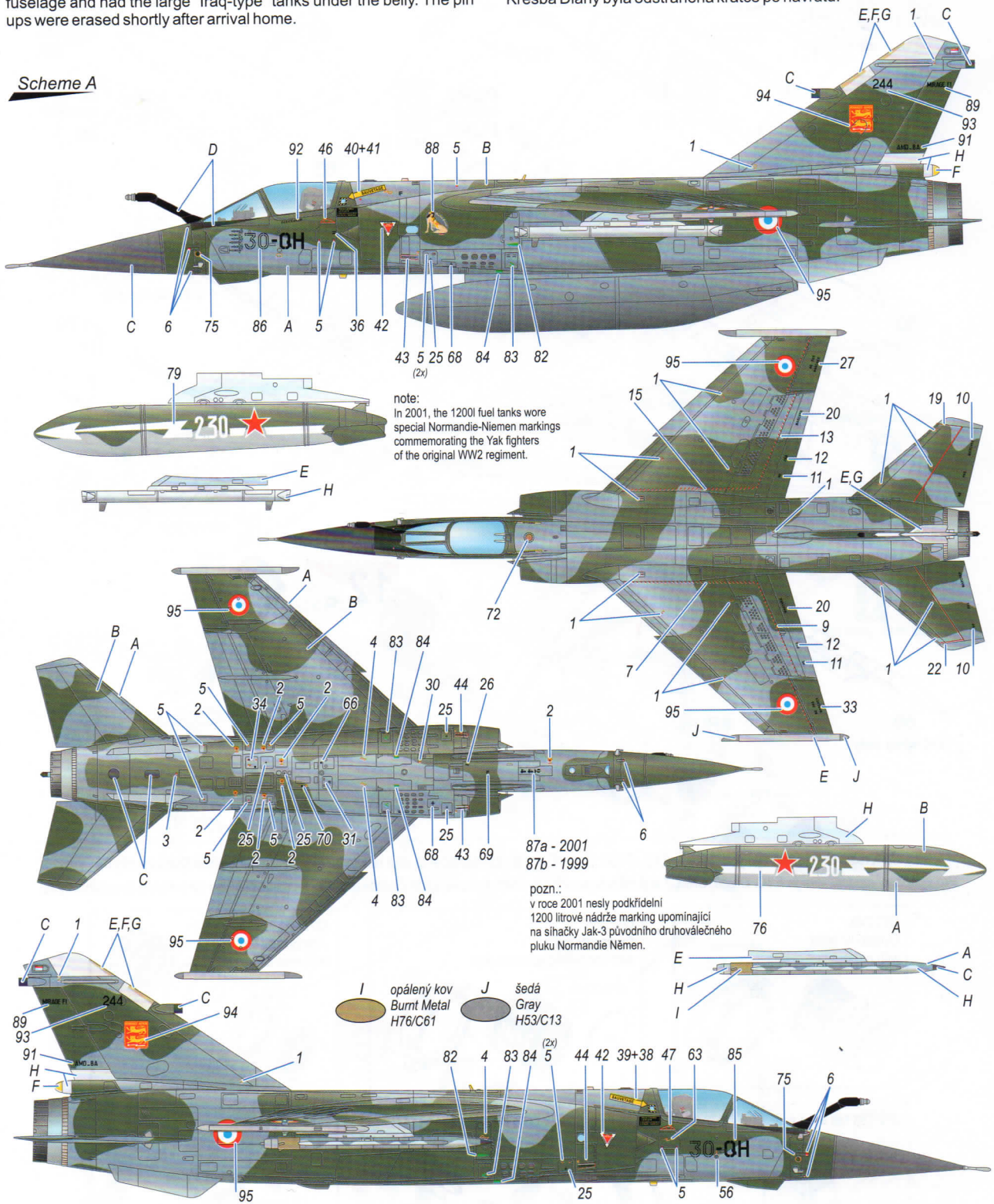

- A modrošedá Greyish Blue FS36152
- B tm.zelená Green FS34079
- C černošedá Black Gray H416
- D černá Black H12/C33
- E sv.šedivá Lt.Gray H51/C11
- F krémová Radome H/C318
- G bílá White H11/C62
- H hliník Aluminium H8/C8

SH72414/A Mirage F.1 Duo Pack - Single Seaters

Mirage F.1JA, FAE807, Escuadron 2122, Base Aerea Tauro, Fuerza Aerea Ecuatoriana / Ecuador Air Force. On 10 February 1995, Two F.1JAs (nos. 806 and 807) clashed with the Peruvian Air Force, downing a pair of Su 22 jets. The kill achieved by machine 807 was credited to FAE's Mayor Raúl Banderas.

Mirage F.1JA, FAE807, Escuadron 2122, základna Tauro, Fuerza Aerea Ecuatoriana (ekvádorské letectvo). 10. února 1995 se ekvádorské Mirage č.806 a 807 střetly s letadly sousedního Peru a sestřelily dva stroje Su-22. Vítězství zaznamenané na boku stroje 807 byl dosaženo majorem Raúlem Banderasem.

**Scheme B**

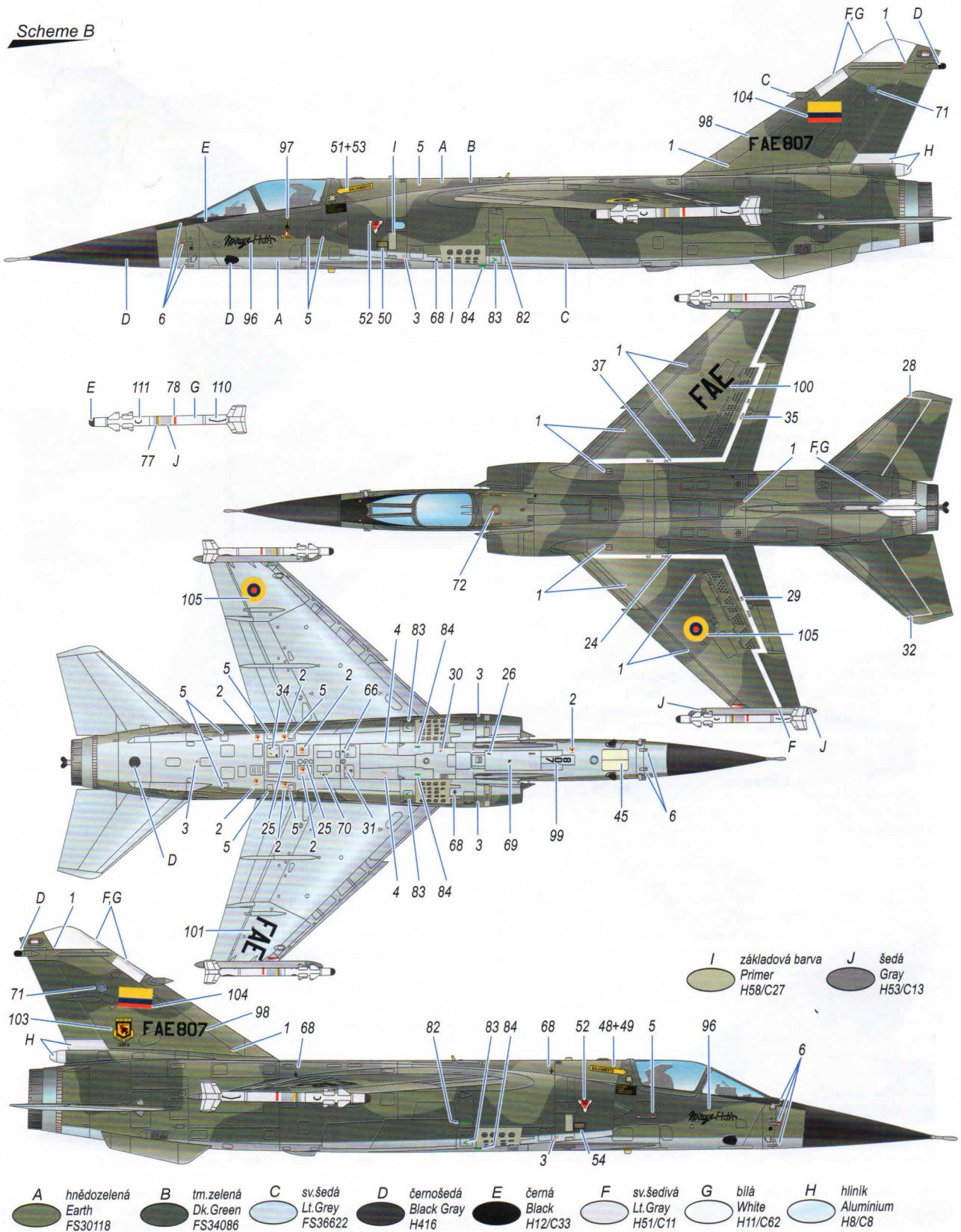

I základová barva Primer H58/C27  
 J šedá Gray H53/C13

A hnědozelená Earth FS30118  
 B tm.zelená Dk.Green FS34086  
 C sv.šedá Lt.Grey FS36622  
 D černošedá Black Gray H416  
 E černá Black H12/C33  
 F sv.šedivá Lt.Gray H51/C11  
 G bílá White H11/C62  
 H hliník Aluminium H8/C8

Mirage F.1EJ, 112, No.1 Sqn, AFB El-Azraq, Silah ul-Jawu al-Malaki al-Urduni / Royal Jordanian Air Force, in service since early 1980s.

Mirage F.1EJ, 112, No.1 Sqn, základna El-Azraq, Silah ul-Jawu al-Malaki al-Urduni (jordánské královské letectvo), používaný od 80.let minulého století.

**Scheme C**

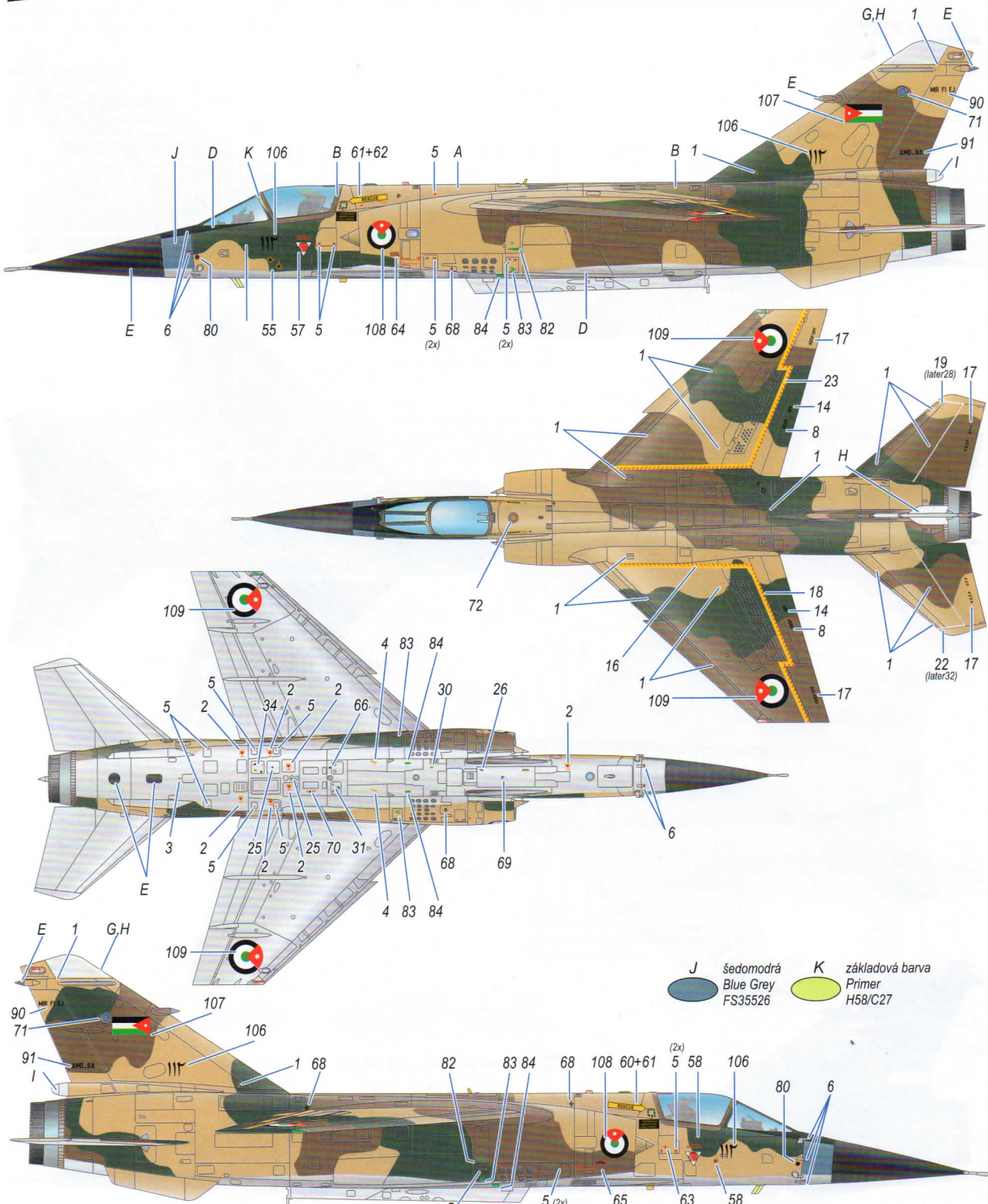

- |                               |                              |                                     |                                  |                                       |                             |                                    |                             |                                 |
|-------------------------------|------------------------------|-------------------------------------|----------------------------------|---------------------------------------|-----------------------------|------------------------------------|-----------------------------|---------------------------------|
| <b>A</b> písková Sand FS20400 | <b>B</b> hnědá Brown FS30140 | <b>C</b> tm.zelená Dk.Green FS34079 | <b>D</b> sv.šedá Lt.Grey FS36622 | <b>E</b> černošedá Black Gray H12/C33 | <b>F</b> černá Black H/C318 | <b>G</b> sv.šedivá Lt.Gray H51/C11 | <b>H</b> bílá White H11/C62 | <b>I</b> hliník Aluminium H8/C8 |
|-------------------------------|------------------------------|-------------------------------------|----------------------------------|---------------------------------------|-----------------------------|------------------------------------|-----------------------------|---------------------------------|

SH72414/A Mirage F.1 Duo Pack - Single Seaters



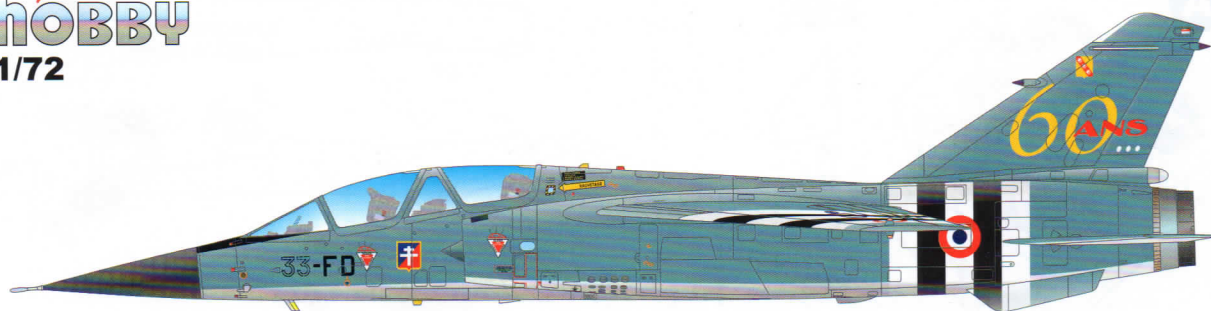

## Mirage F.1 Duo Pack - Two Seaters

**CZ**

Mirage F.1 vděčí za svůj vznik soukromé iniciativě firmy Dassault. Ta sice pracovala z iniciativy Armée de l'Air na několika projektech stíhacích letounů, které měly dát Armée de l'Air nový bojový letoun schopný přepadového stíhání a zároveň taktických útoků s klasickou i atomovou výzbrojí (šlo o možné nástupce Mirage III a byly to projekty označené Mirage IIIT, Mirage IIIF, Mirage G a G8). Armée de l'Air si vybrala nejslibnější projekt Mirage G8 s měnitelnou geometrií křídla. Protože se očekával dlouhý vývoj, rozhodlo se velení Armée de l'Air pro dočasné zavedení Mirage IIIF než bude k dispozici nový Mirage G8A. Objednalo proto stavbu dvou prototypů F.2 a F.3. s motory JTF10 Dassault ale postavil na své náklady ještě jeden prototyp s menšími rozměry a motorem Atar 9K. Tento prototyp, jenž vzletl poprvé 23. prosince 1966 byl vybrán a sériové stroje byly zavedeny do výzbroje Armée de l'Air jako jednomístné stíhačky Mirage F.1C a dvoumístné cvičné stíhačky Mirage F.1B.

V průběhu služby byla část strojů Mirage F.1 modifikována montáží tankovacího nástavce na verzi Mirage F.1C-200. Francouzské letectvo také používalo dvě průzkumné verze, Mirage F.1CR a z Mirage F.1-200 přestavované Mirage F.1CT. Armée de l'Air dostalo celkem 246 kusů všech verzí Mirage F.1. Firma Dassault zkusila nabídnout upravenou Mirage F.1E (E jako European)s výkonnějším motorem Belgii, Dánsku, Nizozemí a Norsku jako náhradu za F-104. Tyto státy daly přednost F-16 a tak Mirage F.1E zůstala jen v prototypu. I tak se ale Mirage F.1 stala úspěšným exportním artiklem. V Evropě ji zařadilo do výzbroje Španělsko a Řecko. V Jižní Americe se jediným uživatelem stal Ekvádor, zato v Africe a Asii byly Mirage F.1 zařazeny do výzbroje Gabonu, Jižní Afriky, Maroka, Libye, Iránu, Iráku, Jordánska, Kataru a Kuvajtu. Mirage F.1 se díky tomu zapojily do mnoha konfliktů po celém světě, od soubojů bez výstřelů řeckých stíhaček s tureckými protivníky, přes francouzské akce v Čadu, ekvádorské pohraniční konflikty s Peru, boje jihoafrických Mirage proti kubánským letounům z Angoly až po účast ve válce proti Iráku, kde létaly Mirage F.1 na obou stranách. I v současnosti má Mirage F.1 ve výzbroji několik států.

rozpětí: 8,40 m, délka: 15,30 m, max. rychlost: Mach 2,2, dolet 3 300 km, dostup: 20 000 m, výzbroj: 2x kanon DEFA 553 ráže 30 mm a kombinace bomb, raket, průzkumných kontejnerů, přídavných nádrží a dalšího vybavení.

**EN**

The Mirage F.1C came about as a private venture by the French Dassault company while it had been engaged in a project designed to fulfil the future needs of the French Air Force (Armée de l'Air) for a modern jet aircraft capable of carrying out interception and tactical attack roles carrying conventional or nuclear armament. A variety of designs were put forward in order to replace the outstanding Mirage III family which were currently filling this role and these were originally designed the Mirage IIIT, Mirage IIIF, Mirage G and Mirage G8. The Armée de l'Air chose the most promising of these designs which was the Mirage G8 with a variable-sweep wing but as the military expected a prolonged development of this advanced (for the day) technology they also decided to go ahead with the simpler Mirage IIIF which could enter service sooner and help bridge the gap before the new G8A could be finished. Two prototypes of the IIIF designated F.2 and F.3 were ordered and these were to be powered by a JTF10 engine.

On top of these government contracts Dassault also decided to go ahead with their own simpler private venture design which featured a smaller airframe powered by an Atar 9K power plant and when the other two more advanced aircraft were cancelled by the French government it was the private venture design which was eventually chosen for military service as the Mirage F.1, featuring a small shoulder mounted wing and conventional tailplane.

The first flight of the Mirage F.1 took place on 23rd December 1966 and production aircraft entered service with the Armée de l'Air as the F.1C single-seater fighter and F.1B two-seater trainer versions. During their service with France a number of these aircraft were upgraded by fitting of IFR probes which resulted in the designation F-1C-200. The Armée de l'Air also flew dedicated reconnaissance and a ground-attack versions of the Mirage F.1 designated respectively as the F.1CR and CT, the latter being converted from the earlier F.1-200 airframes. A total of 246 Mirage F.1's of all versions served with the French and Dassault also tried to offer the aircraft as the F.1E (E for European) version with a more powerful engine to Belgium, Denmark, the Netherlands and Norway as a replacement for their F-104 Starfighter's but these countries chose the F-16 Fighting Falcon instead and the F.1E remained only as a prototype. Nevertheless two other European NATO members did fly the Mirage F.1 with Greece (F.1CG) and Spain (F.1CE, EE & BE) ordering the type and it was also exported successfully further afield. In South America Mirage F.1's were ordered by Ecuador (F.1JA and JE two seaters) for the Fuerza Aerea Ecuatoriana while in Africa and Asia the Mirage F.1 proved especially popular, serving with the air forces of Gabon, South Africa, Morocco, Libya, Iran, Iraq, Jordan, Qatar and Kuwait. Flying with these air forces this variant of the famous Mirage family saw combat action the world, including mock dogfights over the Aegean between Greek F.1's and Turkish fighters, French aircraft saw action over Chad, Libya, Afghanistan, Mali, Ivory Coast and even stood up against Iraqi Mirage F.1's during the 1st Gulf War, Ecuadorian F.1's were used in cross border skirmishes with Peru and South African Mirages also saw extensive action as a ground attack aircraft and fighter during the long Border War with Angola and Mozambique, often coming up against Cuban flown Soviet Mig 17, 21 and 23 jet fighters. Libyan F.1's also saw brief action during the Civil War of 2011 when several of them defected to Malta.

Although it is now quite an old aircraft the Mirage F.1 still sees frontline service with several countries including Libya which is bolstering its remaining fleet by buying some additional ex French aircraft, Gabon has bought six ex South African F.1AZ aircraft and Iran is believed to still fly some of the 24 ex Iraqi Mirage F.1BQ and EQ's which defected here during the Gulf War.

Wingspan: 8.40m, Length: 15.30m, Max.Speed: Mach 2.2, Range: 3,300km, Ceiling: 20,000m, Armament: 2x 30mm DEFA 553 cannon and various combinations of bombs, missiles, recce pods, fuel tanks and other equipment.

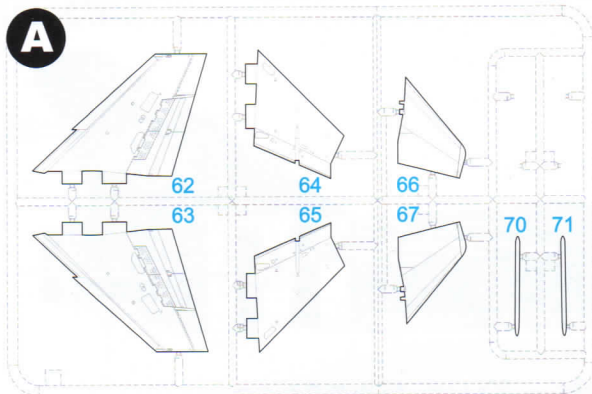

Parts not shown in this diagram are not to be used while you are building the model, or may be used freely, in accordance with your references.

Ke stavbě modelu použijte díly znázorněné v této kresbě. Ostatní díly můžete případně použít podle vašich podkladů.

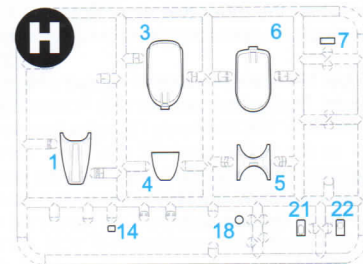
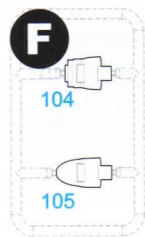
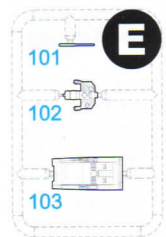
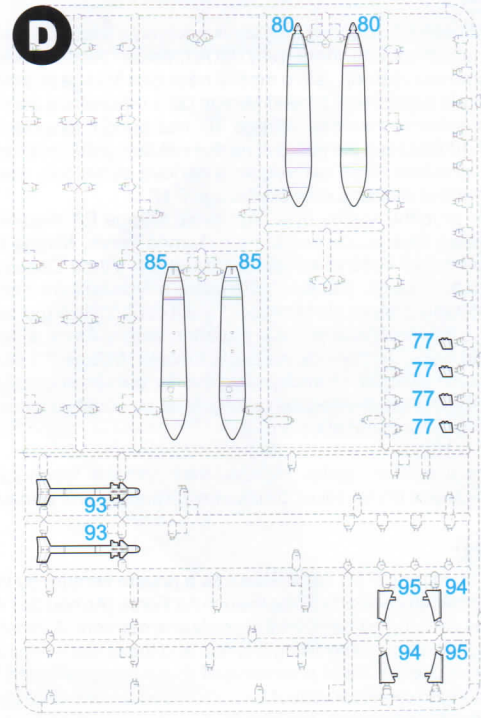
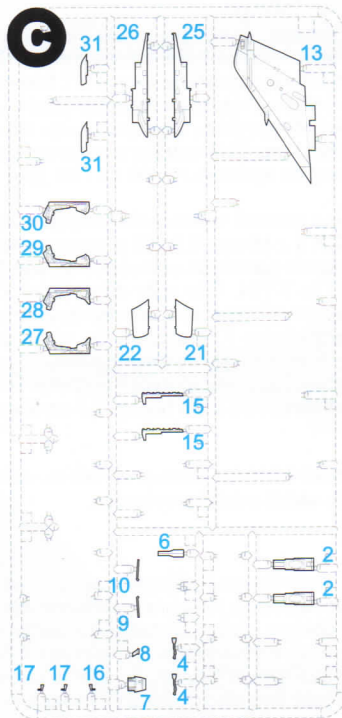
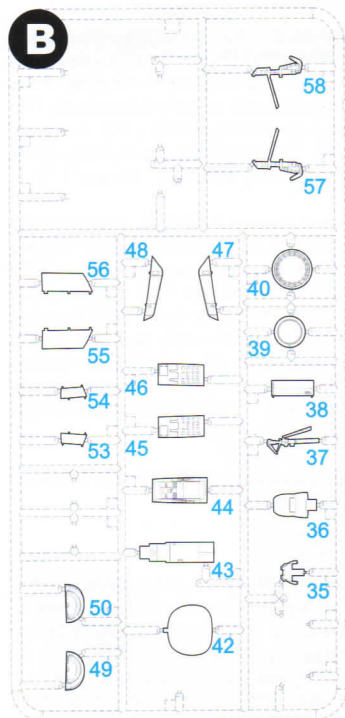

**PUR Parts**

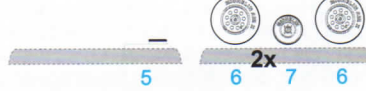

**PE Parts**

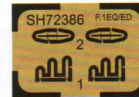

**Barvy GUNZE/ GUNZE Colour No.**

<b>A</b>	Černá / BLACK	H12/C33
<b>B</b>	Hnědočervená / LEATHER	M47/C41+H92/C49
<b>C</b>	Hliník / ALUMINIUM	H8/C8
<b>D</b>	Opálený kov / BURNT IRON	H76/C61
<b>E</b>	Žlutá / YELLOW	H4/C4
<b>F</b>	Červená / RED	H3/C3
<b>G</b>	Červená čirá / CLEAR RED	H90/C47
<b>H</b>	Modrá čirá / CLEAR BLUE	H93/C50
<b>J</b>	Barva pneu / TIRE BLACK	H77/C137
<b>J</b>	Olivová / OLIVE DRAB (2)	H78/C38
<b>K</b>	Světlá Olivová / OLIVE DRAB (1)	H52/C12
<b>L</b>	Chrom. stříbrná / CHROME SILVER	MC211
<b>M</b>	Tmavě šedá / DARK SEAGRAY	H75 / C25

**SYMBOLS**

**?** MOŽNOST VOLBY  
OPTIONAL  
NACH BELIEBEN  
OPTION

**👉** POUŽÍT KYANOAKRYLÁTOVÉ LEPIDLO  
INSTANT CYANOACRYLATE GLUE  
ZYANOAKRYLATKLEBER  
ADHÉSIF CYANOACRYLAT

**📐** OHNOUT  
BEND  
BIEGEN  
COURBER

**👋** ZHOTOVIT NOVÉ  
SCRATCH BUILD  
FERTIGSTELLEN  
ACHEVER

**🔪** REZAT/VRTAT  
CUT OFF/DRILL  
ENTFERNEN  
DETACHER

**🎨** NATŘÍT  
COLOUR  
FARBEN  
PEINDREN

**1** instrument panel  
decals A & B

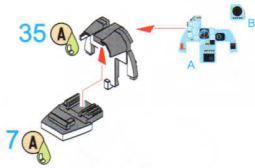

**2a**

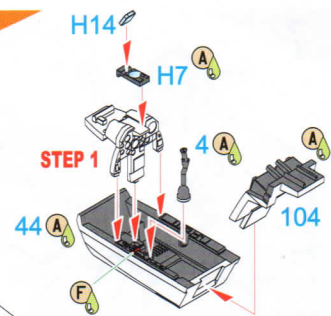

**2b** instrument panel  
decals C & D

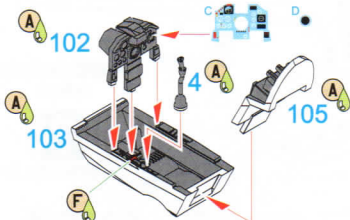

**3**

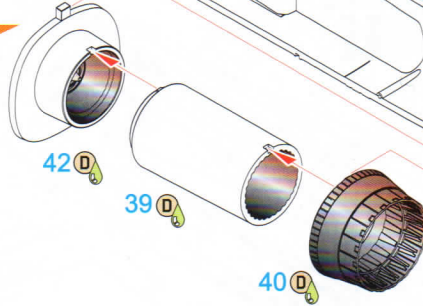

**4**

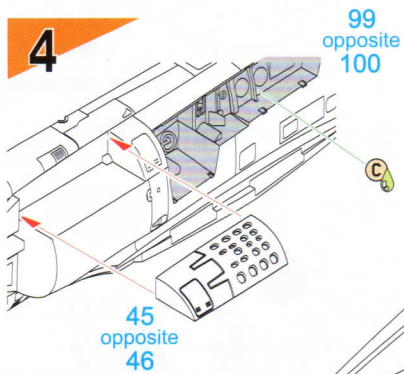

**5**

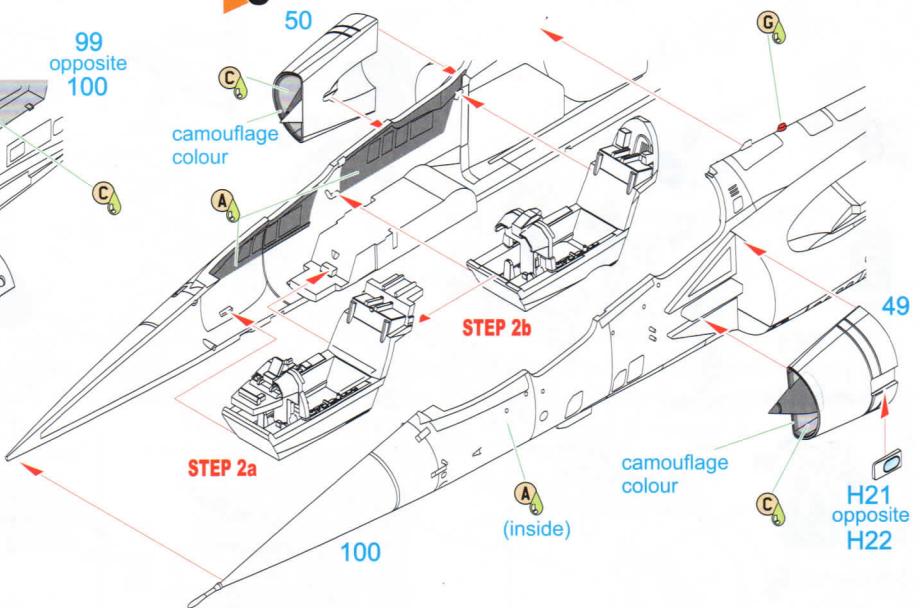

**6**

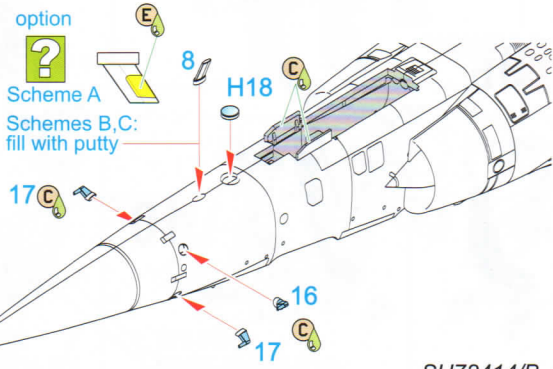

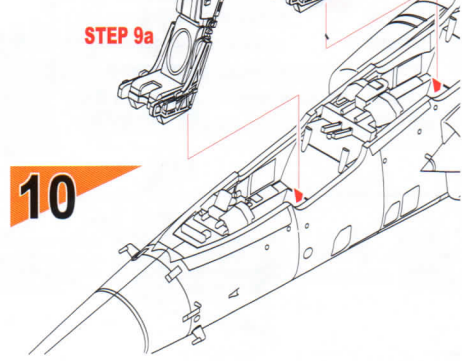
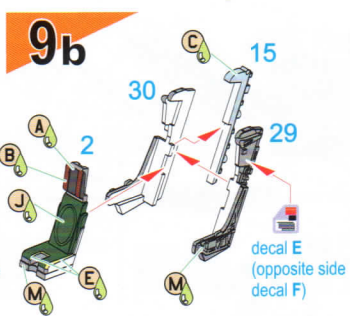
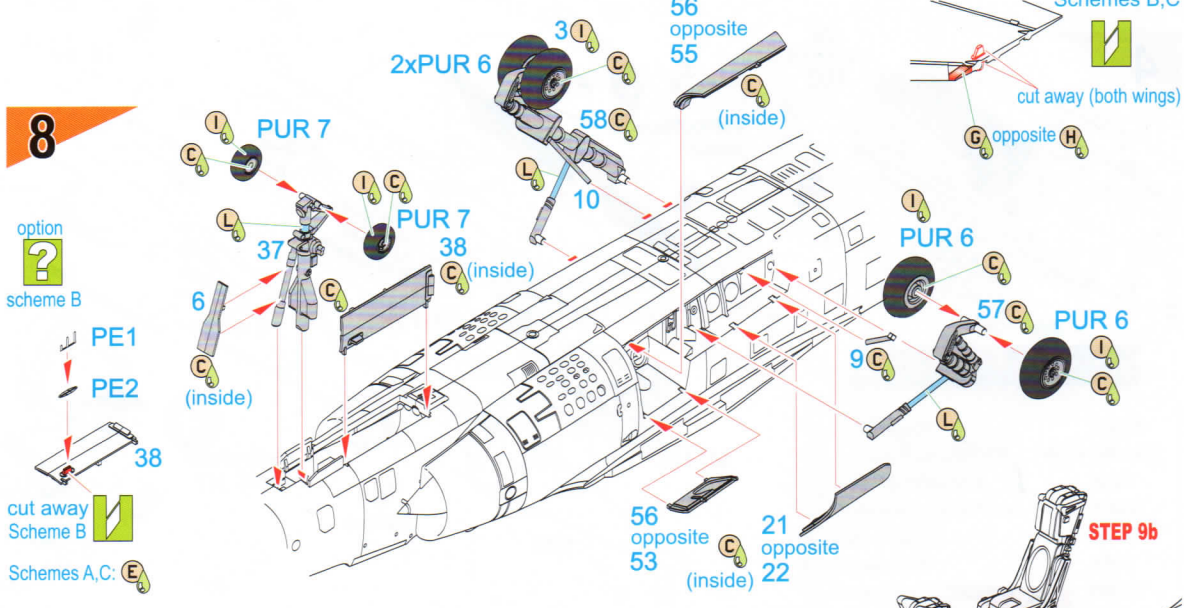
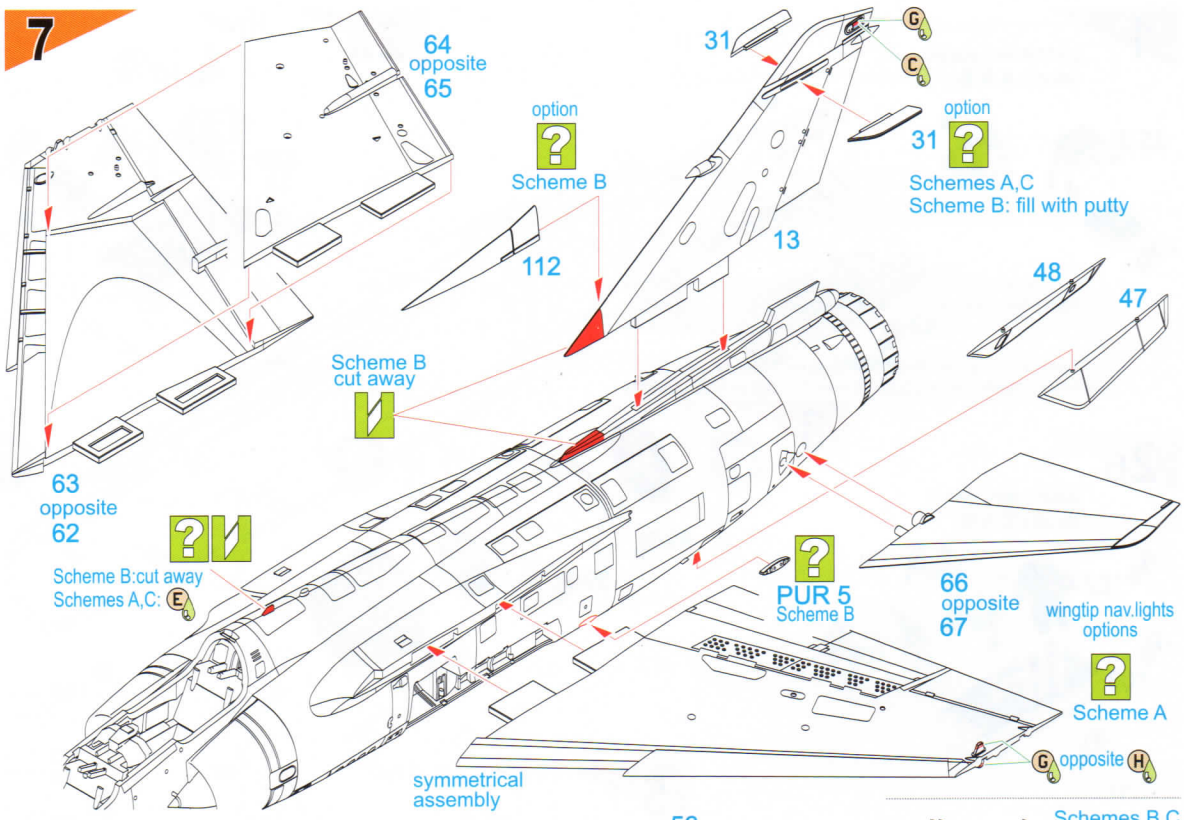

11

? Underwing stores scheme is optional, check your chosen camouflage version.

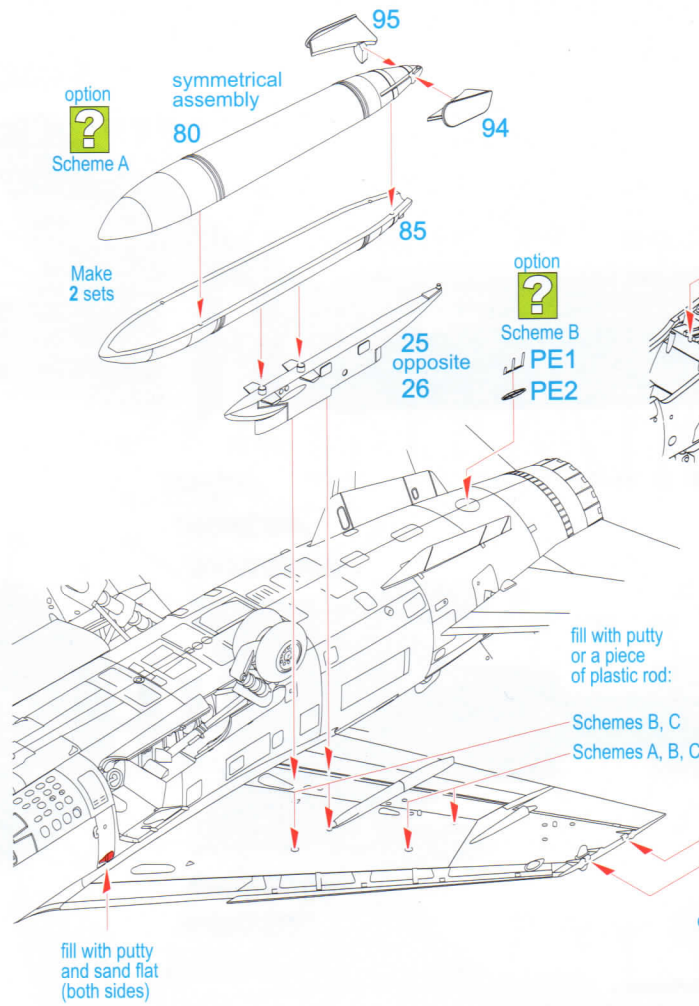

12

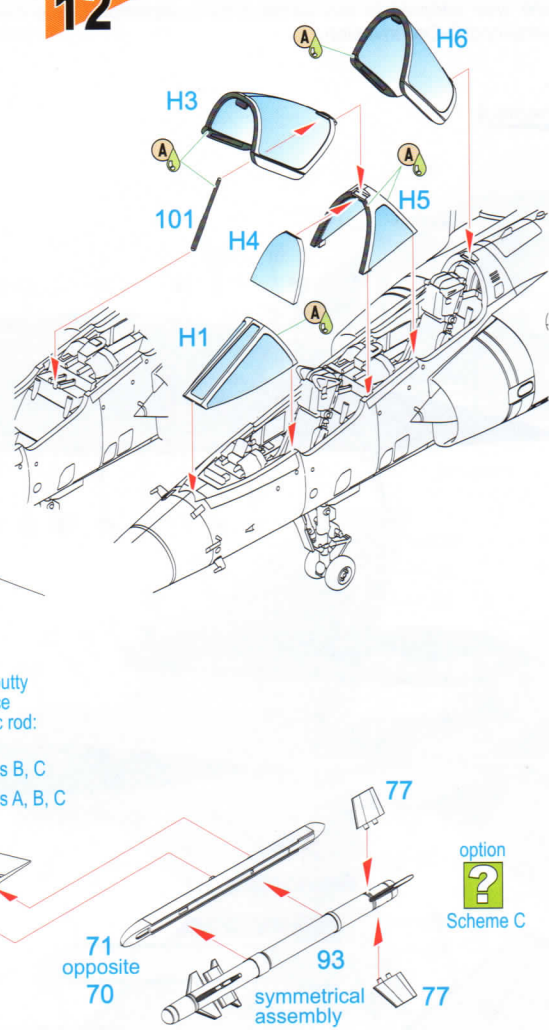

CMK resin sets to improve your Mirage F.1C, C-200, CR, CT and B kits. Available at your retailer or directly via our e-shop [Specialhobby.eu](http://Specialhobby.eu)  
 Pro vylepšení modelů Mirage F.1C, C-200, CR, CT a B můžete použít tyto CMK resinové sady. Žádejte u svého prodejce či přímo na e-shopu [Specialhobby.eu](http://Specialhobby.eu)

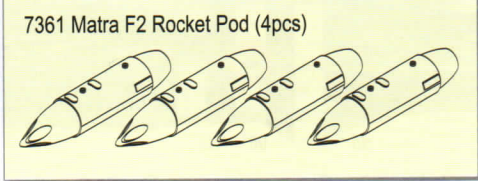
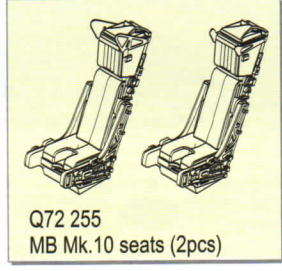
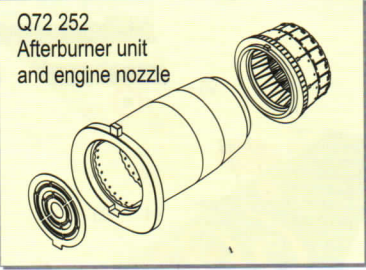
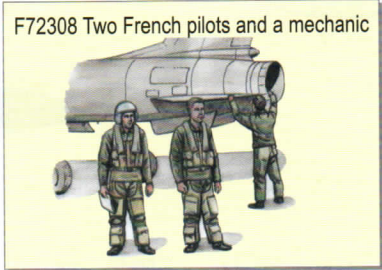
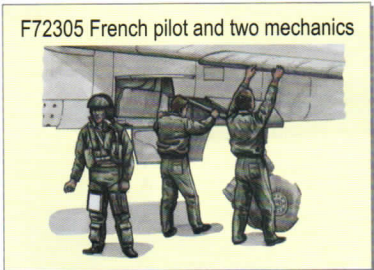

SH72414/B Mirage F.1 Duo Pack - Two Seaters 5

Mirage F.1B, c/n 520, 33-FD, EC 3/33 'Lorraine', Base Aérienne BA 112 Reims, Armée de l'Air (French Air Force), June 2004. Special scheme was adopted to this airframe to commemorate the 60th anniversary of D-Day invasion.

Mirage F.1B, výr.č. 520, 33-FD, EC 3/33 'Lorraine', základna BA 112 Reims, Armée de l'Air (francouzské letectvo), červen 2004. Mirage 33-FD byla opatřena speciálním zbarvením při příležitosti oslav 60. výročí Dne D, spojenecké invaze do Francie.

**Scheme A**

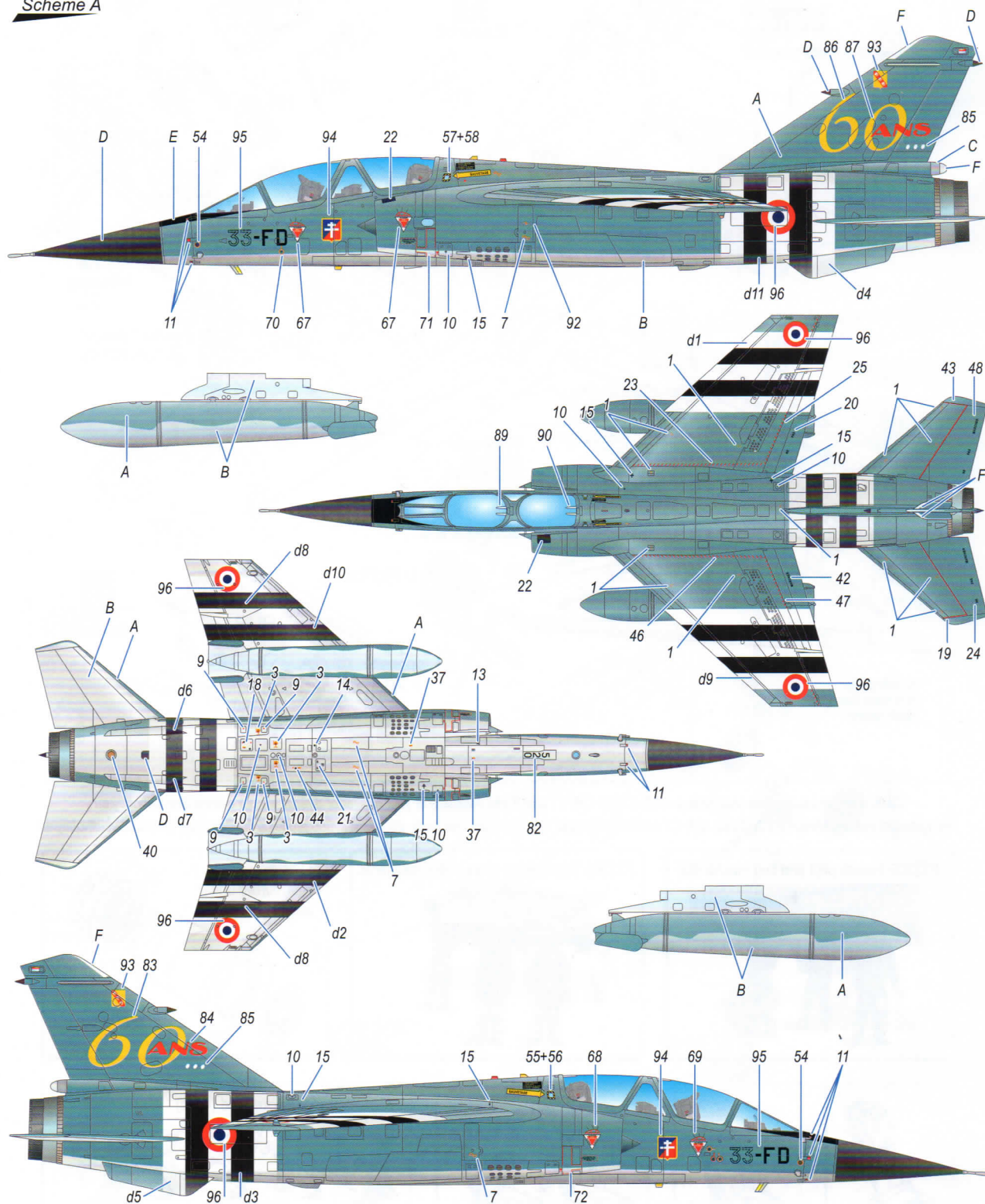

- |          |                                   |          |  |          |                              |          |                                      |          |                           |          |                          |
|----------|-----------------------------------|----------|--|----------|------------------------------|----------|--------------------------------------|----------|---------------------------|----------|--------------------------|
| <b>A</b> | šedomodrá<br>Blue Grey<br>FS35164 | <b>B</b> | mat.hliníková<br>Matt Alu.Paint<br>H8+11/C8+62 | <b>C</b> | hliník<br>Aluminium<br>H8/C8 | <b>D</b> | černošedá<br>Black Gray<br>H416/C116 | <b>E</b> | černá<br>Black<br>H12/C33 | <b>F</b> | bílá<br>White<br>H11/C62 |
|----------|-----------------------------------|----------|--|----------|------------------------------|----------|--------------------------------------|----------|---------------------------|----------|--------------------------|

Mirage F.1BQ, 3-6406, 102 TFS (Tactical Fighter Squadron), 10 TFB (Tactical Fighter Base), Chabahar-Konarak, Niru-ye Hava-ye Artesh-e Jomhuri-ye Eslami-ye Iran / IRIAF - Islamic Republic of Iran Air Force, 2016.

Mirage F.1BQ, 3-6406, 102 TFS (taktická stíhací perut'), 10 TFB (taktická stíhací základna), Chabahar-Konarak, Niru-ye Hava-ye Artesh-e Jomhuri-ye Eslami-ye Iran / IRIAF (iránské vojenské letectvo), 2016.

**Scheme B**



- |   |   |  |   |                                    |                                    |                                   |   |
|---|---|--|---|------------------------------------|------------------------------------|-----------------------------------|---|
| <b>A</b> sv.modrá<br>Lt.Blue<br>FS35488 | <b>B</b> stf.modrá<br>Mid Blue<br>FS35180 | <b>C</b> sv.šedá<br>Lt.Grey<br>FS36495 | <b>D</b> černošedá<br>Black Gray<br>H416/C116 | <b>E</b> černá<br>Black<br>H12/C33 | <b>F</b> šedivá<br>Gray<br>H51/C11 | <b>G</b> bílá<br>White<br>H11/C62 | <b>H</b> světle žlutá<br>Pale Yellow<br>H318/C318 |
|---|---|--|---|------------------------------------|------------------------------------|-----------------------------------|---|
- I** hliník  
Aluminium  
H8/C8      **J** červená  
Red  
H3/C3
- SH72414/B Mirage F.1 Duo Pack - Two Seaters**

Mirage F.1DDA, QA 62/U, 7 Squadron, 1 Fighter Wing, at Doha, Al Quwwat al Jawwiya al Emiri al Qatar / Qatar Emiri Air Force, late 1980s.

Mirage F.1DDA, QA 62/U, 7 Squadron, 1 Fighter Wing, základna Doha, Al Quwwat al Jawwiya al Emiri al Qatar (katarské letectvo), druhá polovina 80.let.

**Scheme C**



H hliník Aluminium H8/C8  
I šedá Gray H53/C13

A písková Sand FS20260  
B tm.hnědá Dk.Brown FS20117  
C střímodrá Mid.Blue FS35231  
D černošedá Black Gray H416/C116  
E černá Black H12/C33  
F šedivá Gray H51/C11  
G bílá White H11/C62

SH72414/B Mirage F.1 Duo Pack - Two Seaters