

## Xtrakit Plastic Aircraft Kit

Produced by Hannants, Harbour Road, Lowestoft, NR32 3LZ, England

# Gloster Meteor T. Mk.7

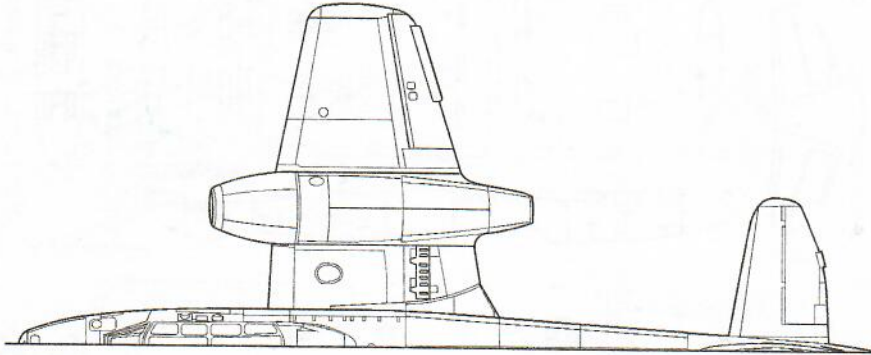
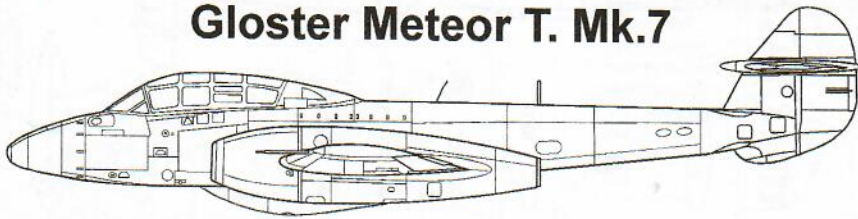

1/72 scale

**HISTORY**

XK 72005

The Gloster Meteor T Mk.7 was a two seat trainer, based on the Meteor F Mk.4. The first one was rebuilt from an aircraft which was damaged during a sales tour of Europe which crash landed in Belgium. It carried the civil registration G-AKPK and first flew on March 19 1948 with Bill Waterton at the controls.

The inspiration was provided by Argentina who had ordered 100 Meteor F MK 4s with pilot training included in the contract. Gloster found that it would be much safer if the instructor was in the aircraft with the trainee pilot and so the T Mk 7 was born.

The RAF soon took an interest in the two seat trainer version and issued technical specification T 1/47 on 16 May 1947. This called for an unarmed dual control trainer. The Royal Navy also took an interest in the proposal and issued a modified specification T 1/47 issue 2 in January 1952.

The first production T Mk.7 made its maiden flight on 26 October 1948, with deliveries taking place between December 1947 and 1954.

The original T Mk.7 was based on the F Mk.IV, but with a longer nose to make room for the two man cockpit. It was discovered that this longer nose actually improved the directional stability of the aircraft. Early Mk.7s were powered by the Derwent V, while later aircraft got the Derwent 8, capable of providing 3,600lb of thrust. Later in the production run the tail was changed to match the one introduced on the F Mk.8, and these aircraft were often known as the T Mk.7 1/2.

WL419 was a T Mk 7 1/2 operated by Martin Baker and is credited with over 200 ejection seat tests. A total of 654 T Mk.7s were built, of which 147 went to overseas operators of the Meteor which included Australia, Belgium, Brazil, Egypt, France, Israel, the Netherlands and Syria.

### **TECHNICAL DATA:**

Span: 11.32 m, Length: 13.2 m, Height 3.9 m, Max. Speed 949 km/h at 3,048 m, Range: 933 km, Weight 4,846 kg (empty) 6,454 kg (loaded), Service Ceiling 13,106m, Armament none.

**KIT PARTS**

**A**

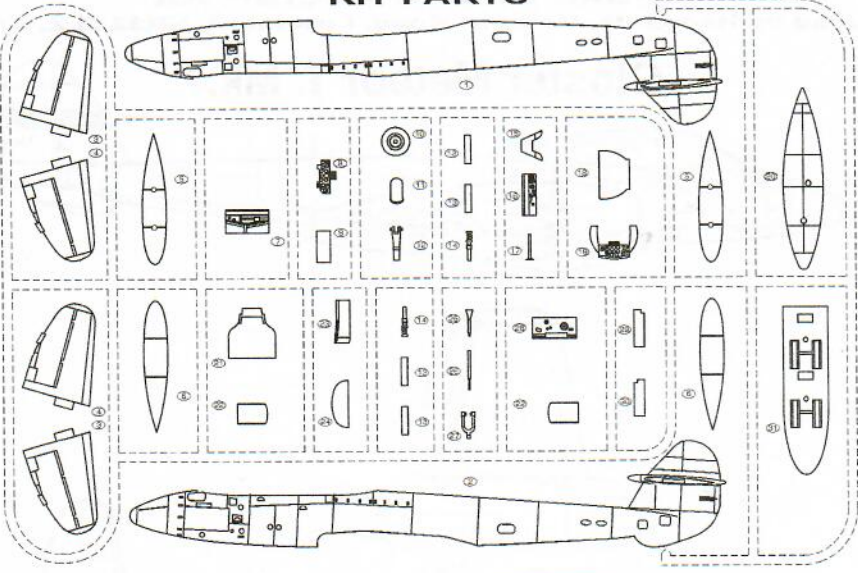

**B**

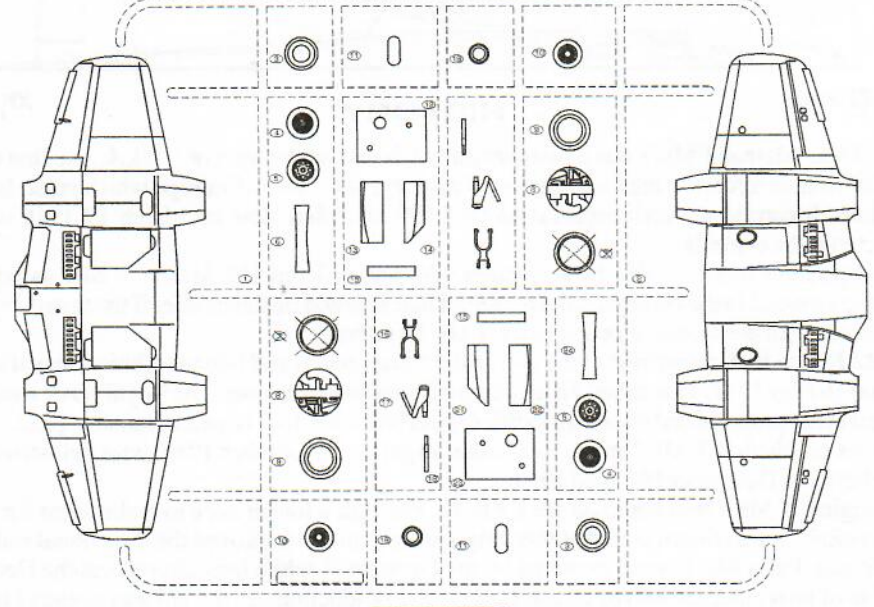

**K**

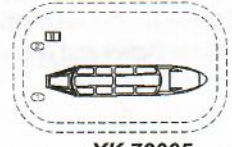

**XK 72005**

**Gloster Meteor T. Mk. 7**

**SYMBOLS**



# ASSEMBLY

**STEP 1**

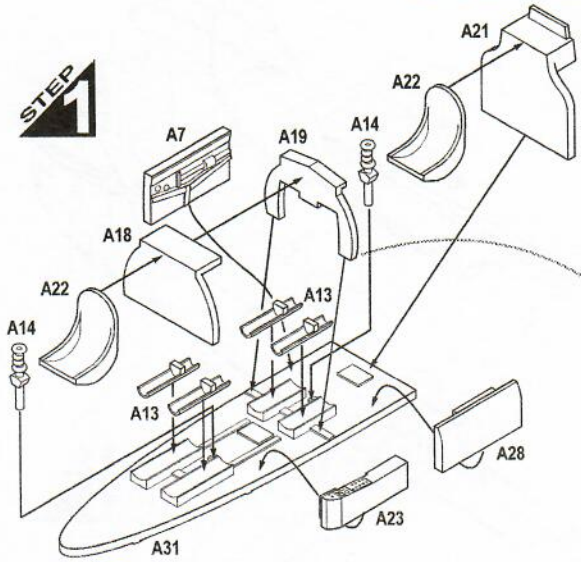

Xtracolor Colour No:		Xtracrylix
DARK GREEN	X001	XA1001
DARK SEA GREY	X004	XA1004
TRAINER YELLOW	X011	XA1011
NIGHT BLACK	X012	XA1012
HIGH SPEED SILVER	X038	
WHITE	X141	XA0141
ALUMINIUM	X142	
EXHAUST	X504	
TYRE BLACK	X505	

**STEP 2**

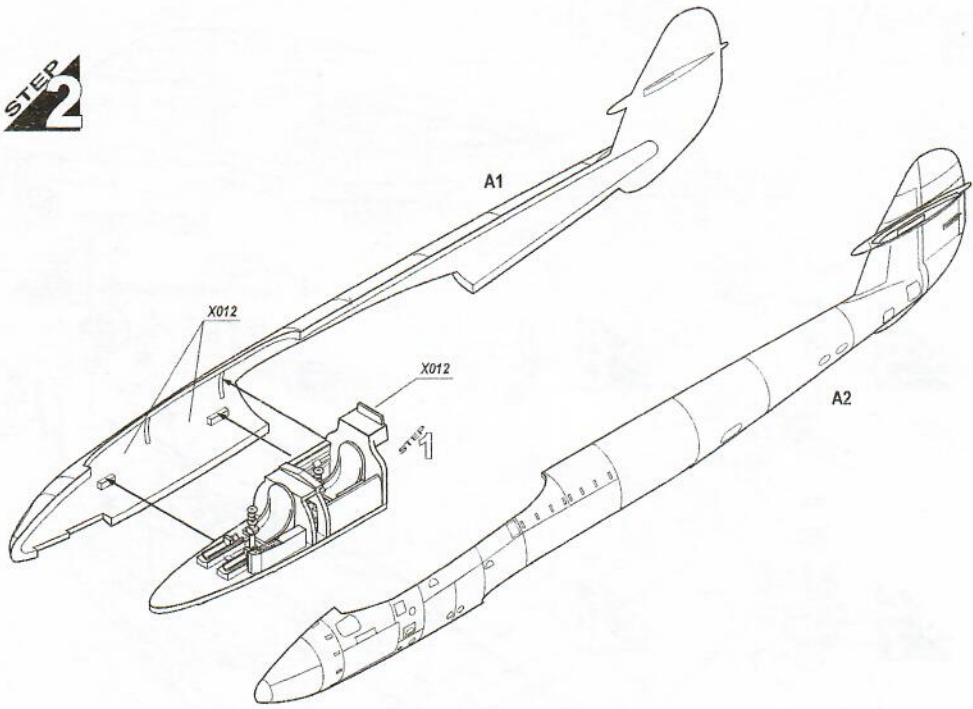

**STEP 3**

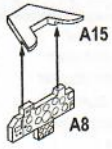

**STEP 4**

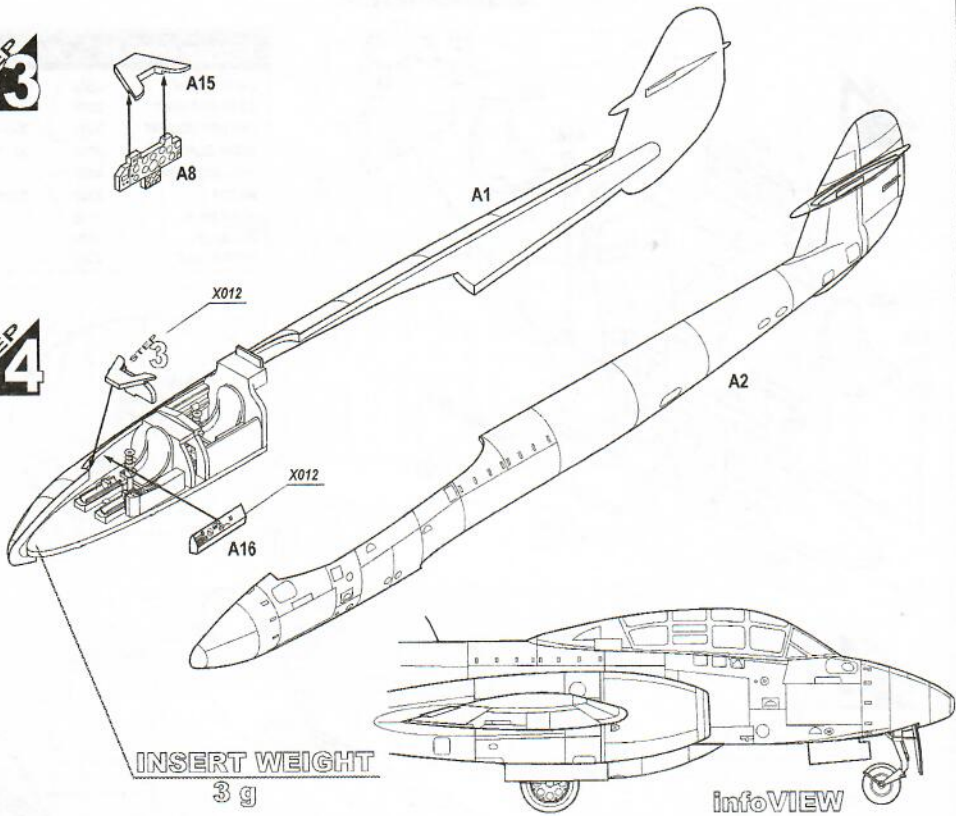

INSERT WEIGHT  
3 g

infoVIEW

**NOTE.**  
\* Attach parts marked \* at Step 16

**STEP 5**

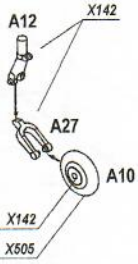

**STEP 6**

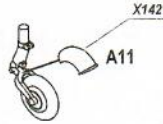

**STEP 7**

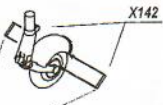

**STEP 8**

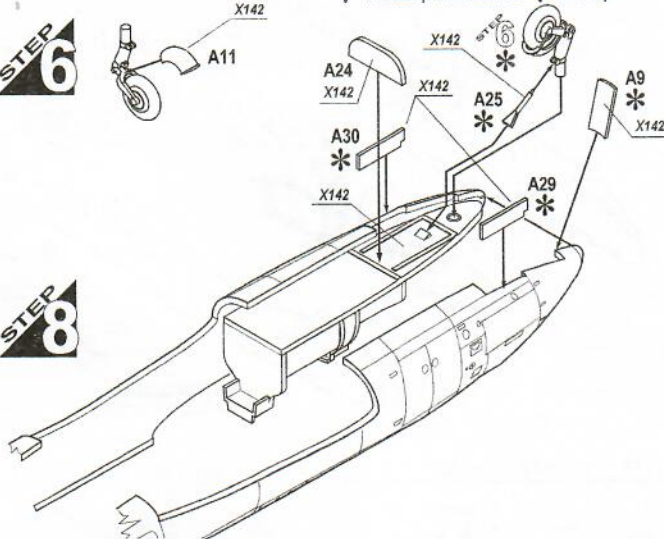

**4**

Gloster Meteor T. Mk. 7

XK 72005

08/2008

# ASSEMBLY

**STEP 9**

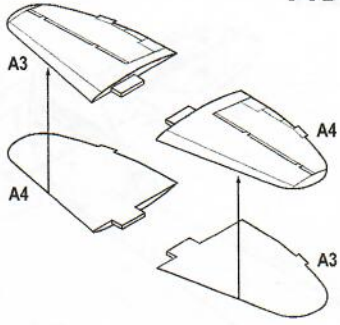

**STEP 10**

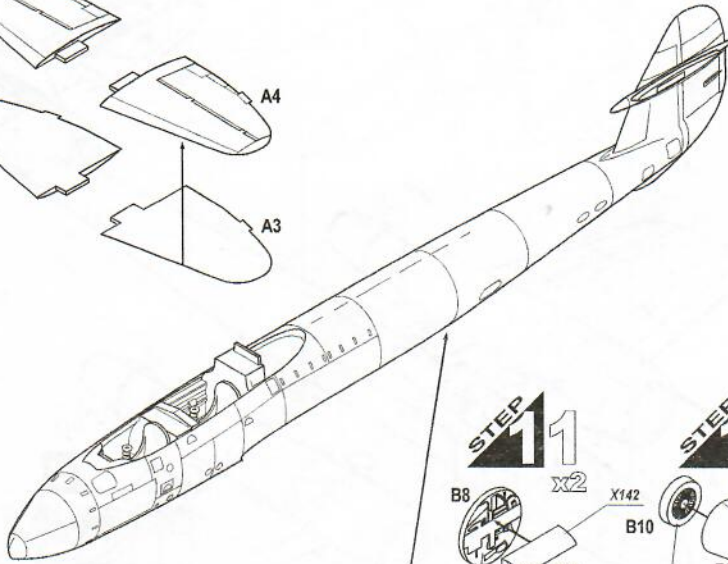

**STEP 11**

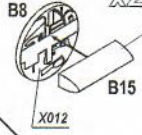

**STEP 12**

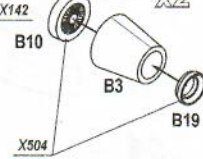

**STEP 13**

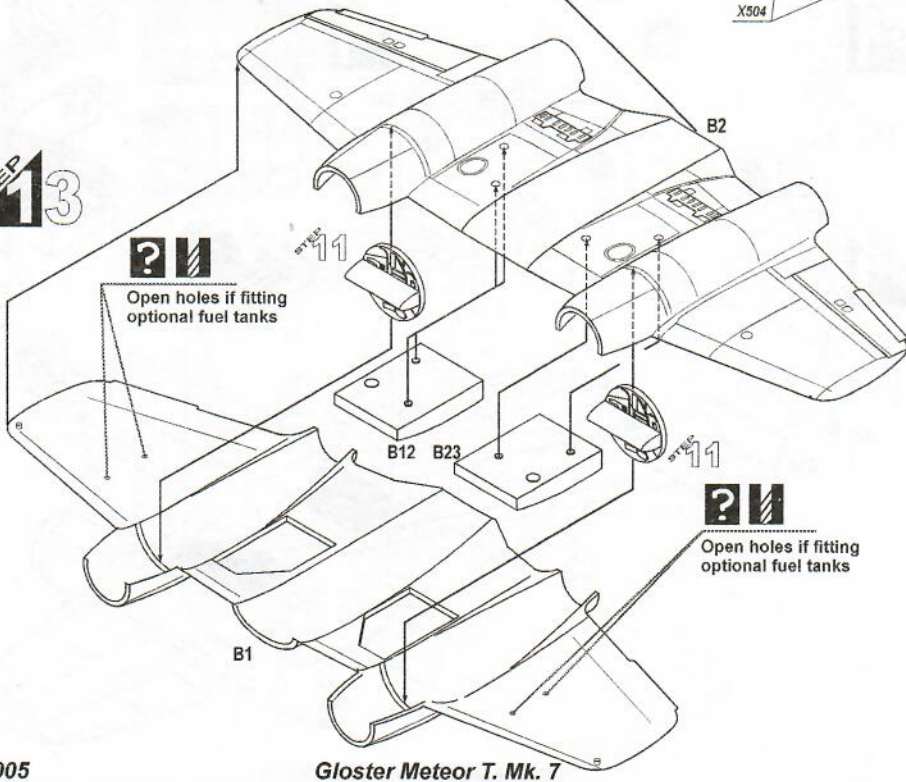

# ASSEMBLY

**STEP 14**

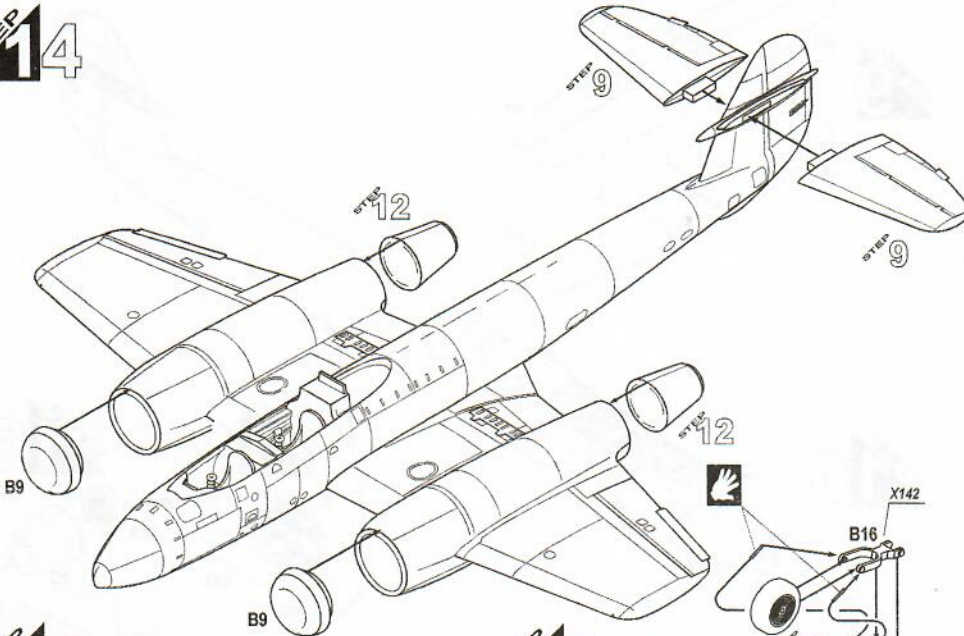

**STEP 15**

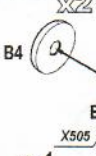

**STEP 16**

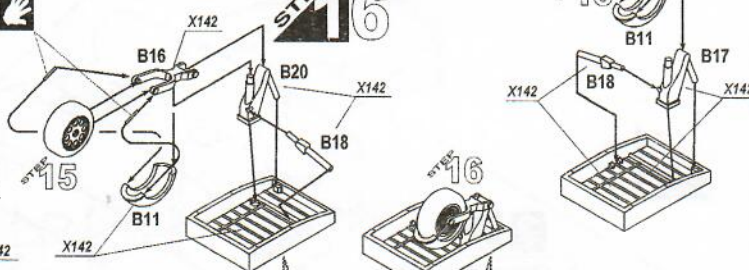

**STEP 17**

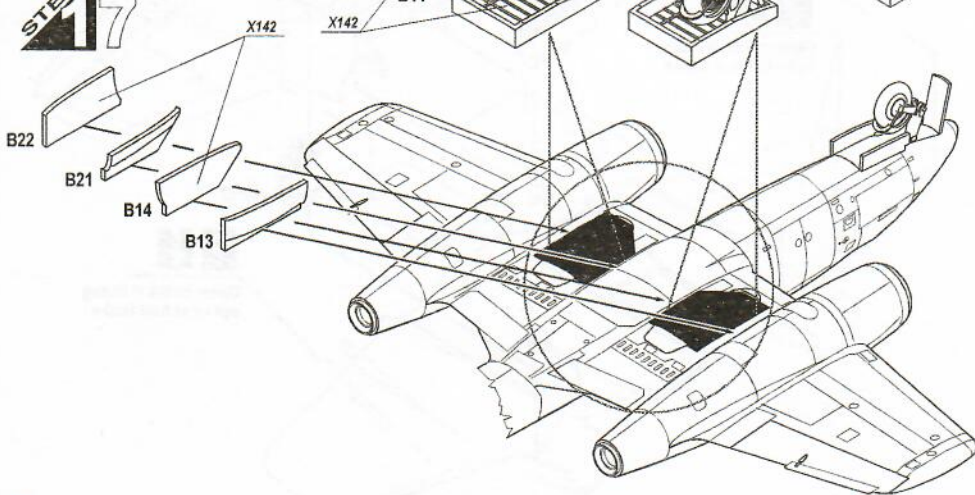

**6**

*Gloster Meteor T. Mk. 7*

XK 72005

02/2003

# ASSEMBLY

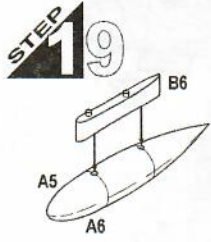
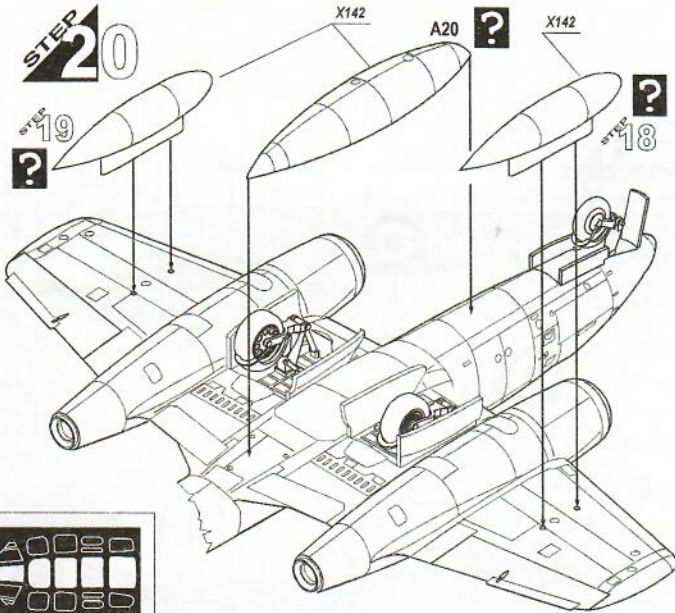
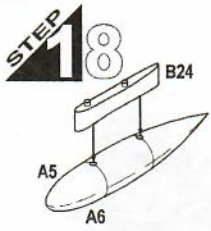

## Canopy Mask

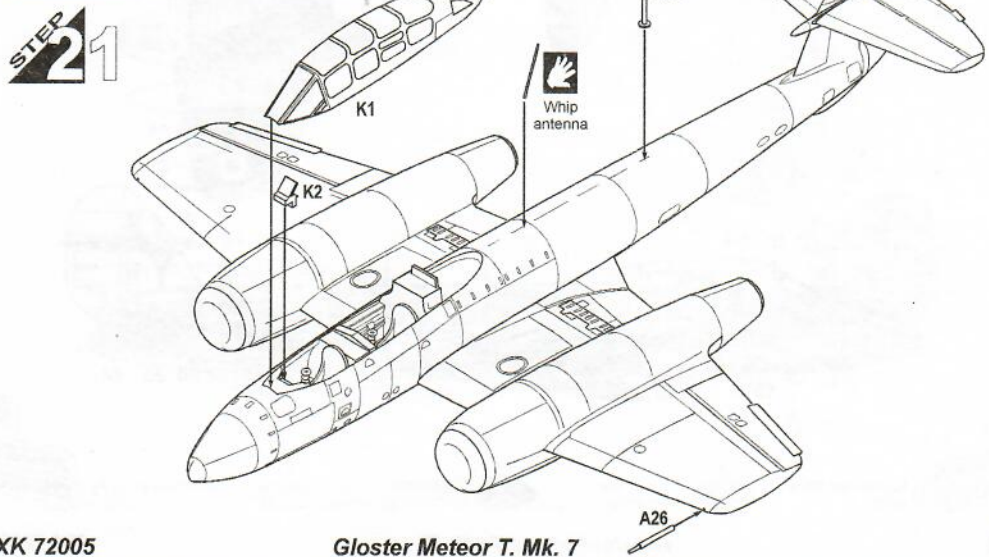
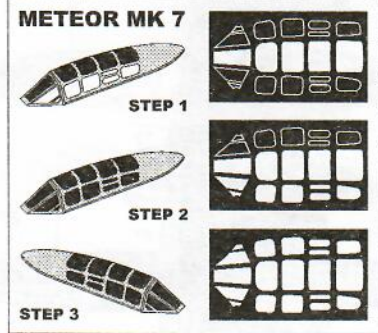

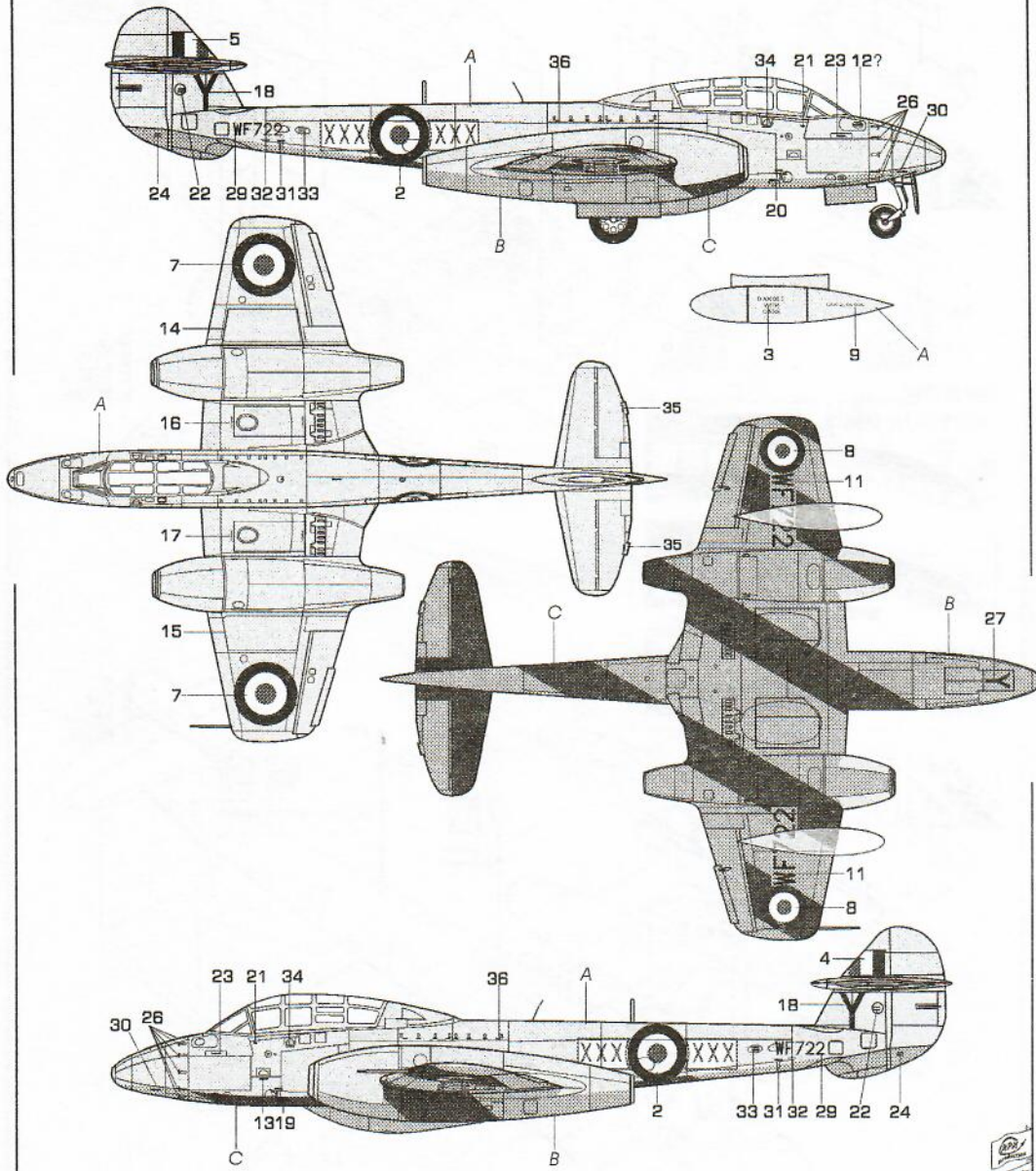

- A High Speed Silver X038
- B Trainer Yellow X011/XA1001
- C Night Black X012/XA1012





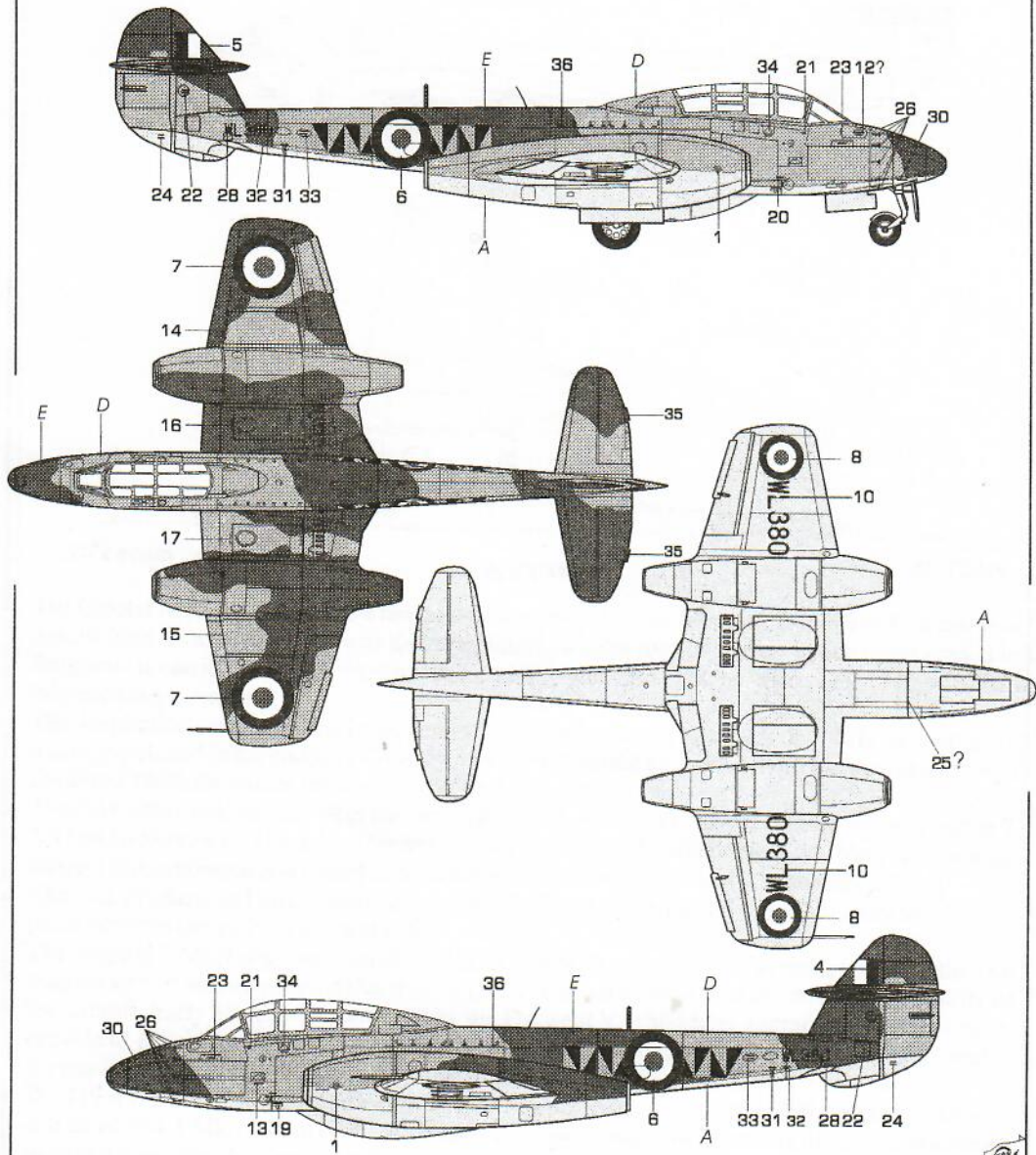

- A** High Speed Silver X038
- D** Extra Dark Sea Grey X004/XA1004
- E** Dark Green X001/XA1001



XK 72005

Gloster Meteor T. Mk. 7

9

08/2008

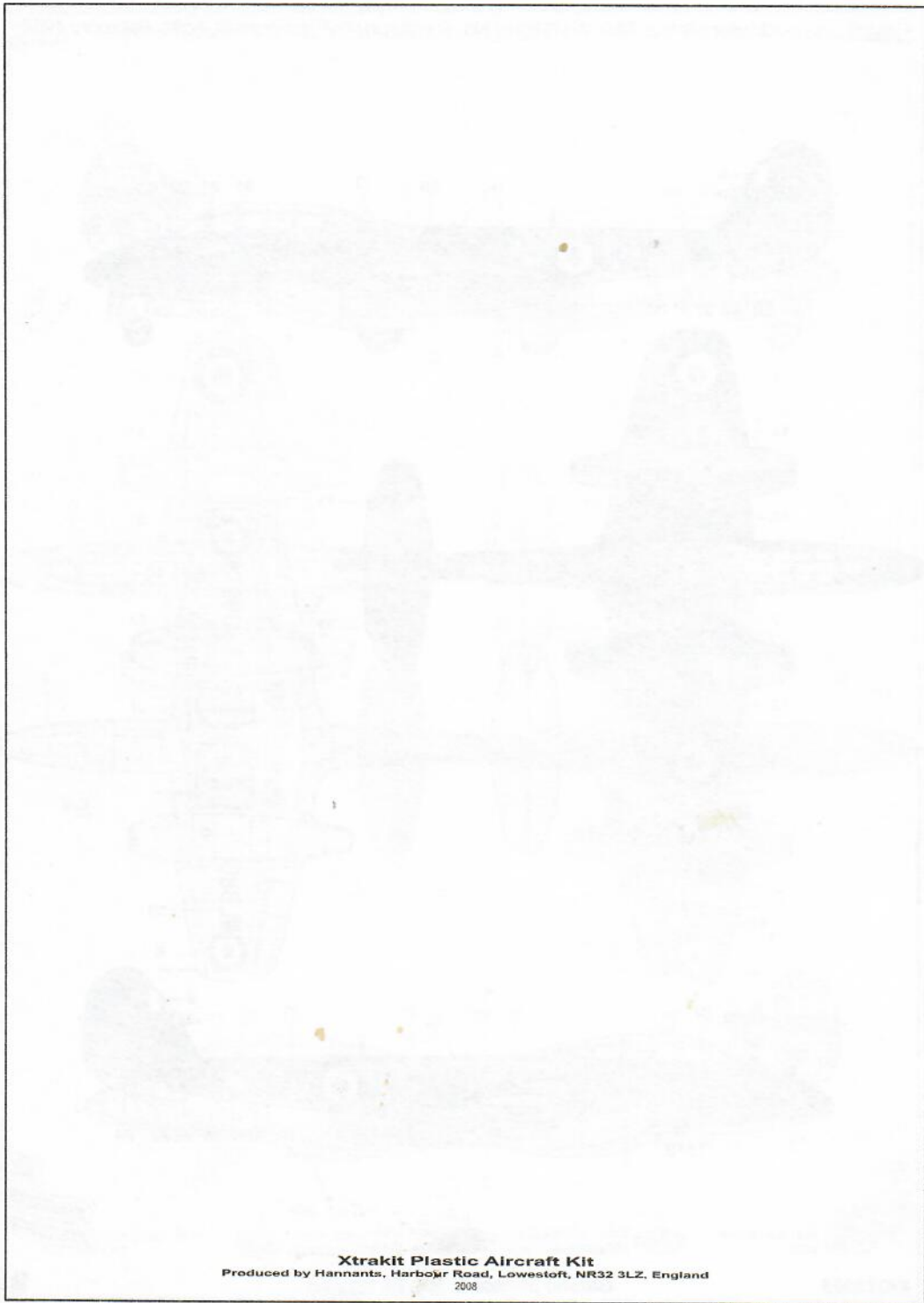

**Xtrakit Plastic Aircraft Kit**  
Produced by Hannants, Harbour Road, Lowestoft, NR32 3LZ, England  
2008

Handwritten mark or signature in red ink.