

Amphibious Assault Ship (LPD) H.M.S. FEARLESS

1/350 Scale

History

In the late 1950s early 1960s the Royal Navy recognised the need to be able to provide and support an amphibious assault force made up of Royal Marines and their equipment plus any services required to establish a beach landing site. The ships needed to be able to support landing craft as well as helicopter operations and be large enough to house the vehicles and armoured vehicles that would be necessary to carry out operations ashore, as well as providing a command and control facility to oversee operations.

HMS Fearless would be the first purpose built Landing Platform Dock (LPD) to be built for the Royal Navy and was based on an existing American design that incorporated an array of specific additions for the Royal Navy's operational needs. She was to carry four large Landing Craft Utilities (LCU), capable of transporting up to two Centurion Main Battle tanks each. Another four Landing Craft Vehicle and Personnel LCVP were to be carried on davits as well as the standard ships boats. A large internal vehicle deck with access to the landing craft dock and the flight deck could house an assortment of vehicles needed for the particular task in hand. Two ships of this class were ordered, HMS Fearless and HMS Intrepid.

HMS Fearless was laid down at the Harland and Wolff, Belfast Shipyard on 25th July 1962 and launched 19th December 1963. After completion and builders trials she was accepted into the Royal Navy and commissioned on 25th of November 1965.

She was soon to see service in her intended role, along with her sister ship Intrepid, during the counter terrorism operations in Aden operating a selection of Royal Air Force aircraft and acting as a command platform throughout the period leading up to the British withdrawal from the region.

After the Aden experiences, Fearless took on a new role, providing the venue in 1968, for talks between British Prime Minister Harold Wilson and the Rhodesian Premier Ian Smith after the earlier Rhodesian Unilateral Declaration of Independence (UDI) from Britain.

Between 1969 and 1971 Fearless found herself touring the Far East, during which time, she found herself providing disaster relief to Bangladesh following a major typhoon that had caused total havoc amongst the widespread villages and townships.

In July 1972 HMS Fearless ferried several Centurion AVRE demolition vehicles, derived from the Centurion tank, to Northern Ireland to be deployed there as part of Operation Motorman. Then in 1977 Fearless featured in the James Bond film "The Spy Who Loved Me" which was filmed off the Island of Malta the previous year. Such was the variety of roles that were asked of her.

Soon things were to get more hectic and the role that Fearless and Intrepid had been designed for was to come to pass.

In 1982 both HMS Fearless and HMS Intrepid were part of the British Task Force committed to Operation Corporate, the re-taking of the Falkland Islands in the South Atlantic from the invading Argentine forces that had occupied the islands and South Georgia in late March.

The ships had been refitted with the latest satellite communications equipment and were able to host the staff of the Amphibious Force Commander Commodore Michael Clapp and the commanding officer of 3 Commando Brigade, Brigadier Julian Thompson and his staff.

Fearless and Intrepid were to enter San Carlos water and initiate the landings by the Royal Marines and Parachute Regiments on the 21st May 1982. The main assault had begun with the landing craft from both ships shuttling back and forth ferrying troops and equipment ashore, whilst helicopters operated from their decks doing the same.

That same day HMS Ardent (Type 21 Frigate) had come under a concentrated attack and sunk whilst being stationed to the south, providing Naval Gunfire Support (NGS) for the landings. Two days later received the HMS Antelope the same treatment and two of HMS Fearless's landing craft were involved in the rescue of her crew. Foxtrof 7 one of the LCVP's carried by Fearless, the coxswain of which received a commendation from Admiral Sir John Fieldhouse, and Foxtrof 4 one of the LCU commanded by Colour Sergeant Brian Johnston who was awarded the Queens Gallantry Medal for rescuing other crew members.

Unfortunately on the 8th June whilst ferrying supplies and vehicles around the island to support the landings in Fitzroy, Foxtrof 4 was bombed by enemy aircraft and sunk in Choisel Sound. Colour Sergeant Johnston and five other crew members were killed and two more injured in the attack.

After the Argentine surrender on 14th June HMS Fearless and HMS Intrepid returned home to Portsmouth Naval Base, bearing the scars of battle. She had been strafed by enemy aircraft several times and had some near misses with bombs, but had come through with flying colours. Job done.

Fearless was placed in reserve in 1985 for three years prior to a major refit at Devonport. She recommissioned in 1991 sporting the new Vulcan Phalanx CIWS mountings that replaced her aging Sea Cat missile system and the new 20mm BMARC cannon that replaced the old WW2 vintage 40mm Bofors.

She was to spend the next few years as part of the Dartmouth Training Squadron where she supported the sea training phase of officers from BRNC Dartmouth. She was due to take part in operations in the Gulf, but that role was handed to HMS Ocean in 2000. Fearless carried on in service, taking part in amphibious warfare exercises that took her to the Indian Ocean and Far East, but her days were numbered, to be replaced by newer and larger vessels HMS Albion and HMS Bulwark that were now taking shape in the builders yards.

HMS Fearless was withdrawn from service and decommissioned 18th March 2002 and moored up in Fareham creek near Portsmouth, along side her sister HMS Intrepid and mothballed for the next five years. In late October 2007 HMS Fearless was towed to Ghent in Belgium to be broken up.

Specifications

Length : 520 ft (160 m) Beam : 80 ft (24 m) Draught : 21 ft (6.4 m) Displacement : 12,120 tons (Full Load)
Propulsion : 2 x English Electric 2 shaft geared Steam Turbines at 22,000 shp Speed : 21 knots Complement : 580
Landing Platform could operate up to five Sea King sized helicopters.

Armament as of 1982

4 x Quadruple Sea Cat Missile Launchers 2 x 40mm Bofors Mk VII Single Mountings
? x 7.62mm GPMGs on Single Mountings located at various vantage points.

Armament as of 1991

2 x Vulcan/ Phalanx CIWS Mountings 2 x 20mm BMARC GAM B01 Single Mountings

General Precautions

When assembling a Resin / Photoetched metal kit, certain precautions must first be taken.

1. Resin dust can be harmful if inhaled. It is recommended that you wear a suitable dust mask when drilling or sanding resin parts.
2. Cyano adhesives (super glues) are generally used to assemble this type of kit. Care must be taken when using this type of adhesive as it will bond in seconds. Follow the advice on the container.
3. Wash resin parts in a solution of warm soapy water before assembly. This will remove any residual mold release agents and ensure a good key for painting.
4. Soak photoetch parts in a suitable solvent, such as white spirit, to degrease the surfaces prior to painting.

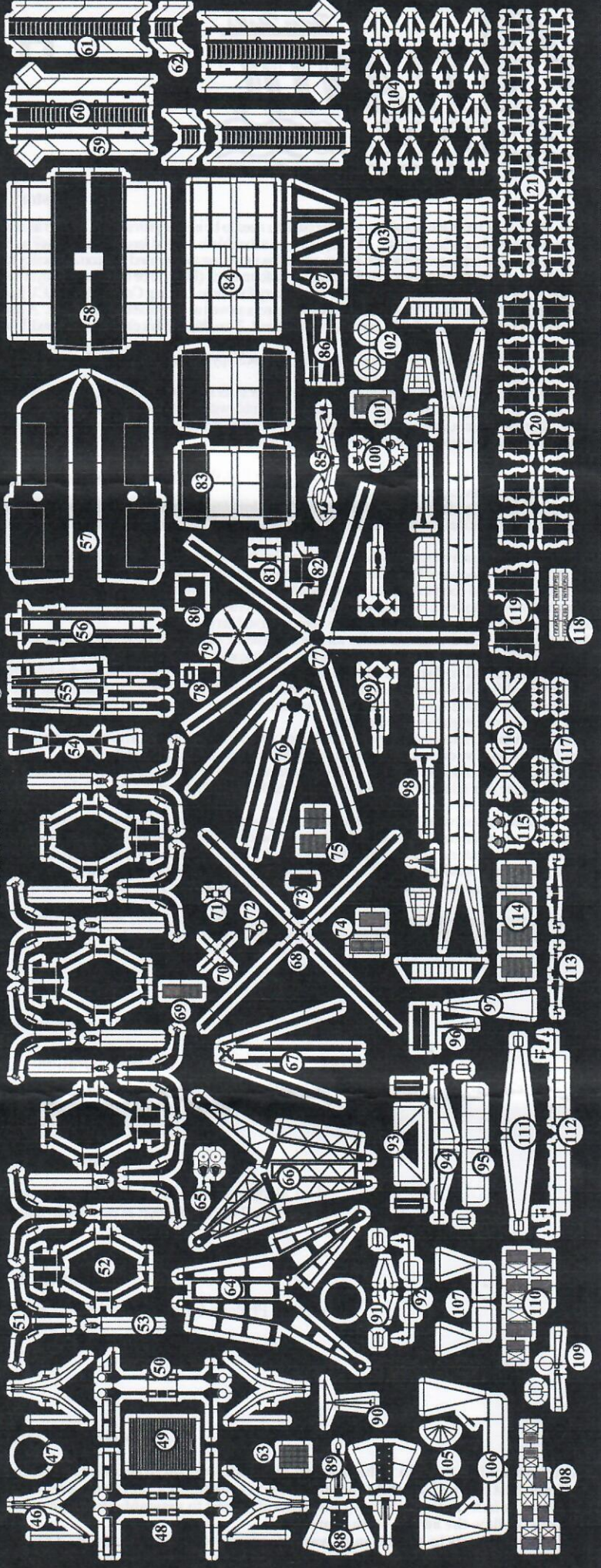
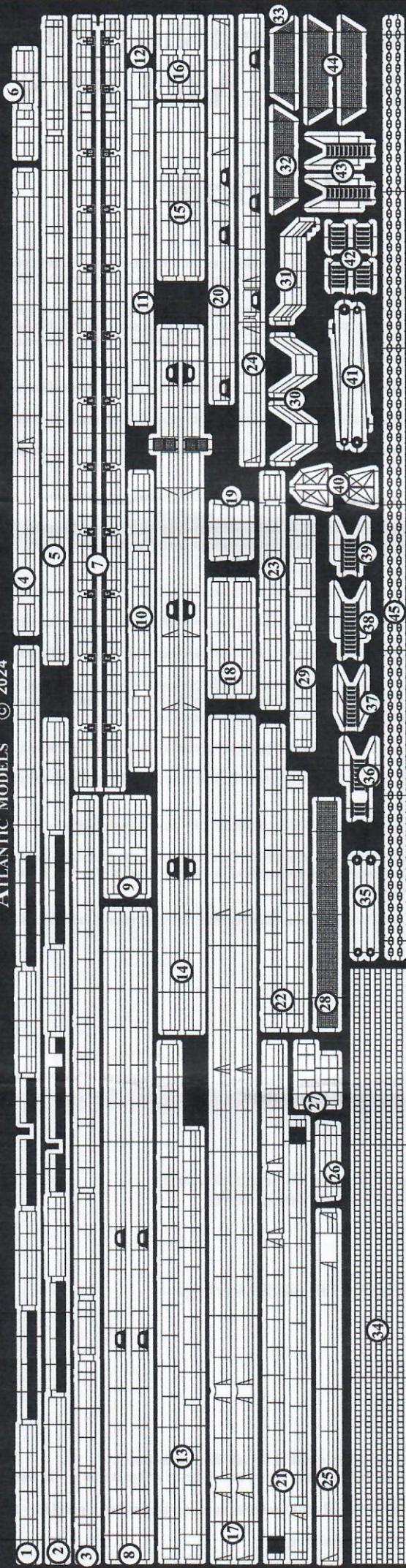

Photo-Etched Metal Parts (Part A)

- | | | |
|--|--|---|
| 1. Railings (01 Deck Port) | 16. Railings (Fwd Life Raft Racks (Aft)) | 31. Railings (Port Crane Steps) |
| 2. Railings (01 Deck Stbd) | 17. Railings (Flight Deck Sides) | 32. Safety Nets (Sea Cat Stbd Aft) |
| 3. Railings (Catwalk Stbd) | 18. Railings (SCOT Radome Platforms) | 33. Safety Nets (Sea Cat Port Aft) |
| 4. Railings (01 Deck Forward) | 19. Railings (Fore Mast Sirens) | 34. Vertical Ladder Stock |
| 5. Railings (Catwalk Port) | 20. Railings (Quarterdeck Port) | 35. Quarterdeck Crane Rigging |
| 6. Railings (Vent Boxes Port) | 21. Railings (04 Deck) | 36. Inclined Ladders (Quarterdeck Stbd) |
| 7. Railings (Dock Catwalks) | 22. Railings (Comms House Roof) | 37. Inclined Ladder (FlyCo Upper) |
| 8. Railings (Main Deck Midships) | 23. Railings (Main Mast Top) | 38. Inclined Ladder (FlyCo Lower) |
| 9. Railings (Searchlights Platforms) | 24. Railings (Quarterdeck Stbd) | 39. Inclined Ladder (FlyCo Middle) |
| 10. Railings (Fore Mast Platform) | 25. Railings (Flight Deck Aft) | 40. HF/DF Antenna Assembly) |
| 11. Railings (03 Deck Forward) | 26. Railings (Main Mast Fwd Platform) | 41. Flight Deck Crane Rigging |
| 12. Railings (182 Winch Deck) | 27. Railings (Flight Deck Crane) | 42. Inclined Ladders (Catwalk Access) |
| 13. Railings (03 Deck Aft) | 28. Flight Deck Aft Safety Nets | 43. Inclined Ladders (03 - 04 Deck Aft) |
| 14. Railings (Fo'c'sle) | 29. Railings (Vent Boxes Stbd) | 44. Safety Nets (Sea Cat Forward) |
| 15. Railings (Fwd Life Raft Racks (Fwd)) | 30. Railings (Flight Deck Access) | 45. Anchor Chain Stock |

Photo-Etched Metal Parts (Part B)

- | | | |
|--------------------------------------|---|--------------------------------------|
| 46. Boat Davit (Cheverton/ Whaler) | 71. Wessex Helicopter Rotor Hub Doubler | 97. Yardarm Stay (Main Mast Top Aft) |
| 47. Funnel Badge Disc | 72. Wessex Helicopter Tail Wheel | 98. Landing Craft Fittings (LCU) |
| 48. Boat Davit Supports (Stbd) | 73. Wessex Helicopter Tail Plane | 99. Dan Bouy Marker |
| 49. Vehicle Deck Roller Door | 74. Vent Grills (FlyCo) | 100. Signal Lamps (Small) |
| 50. Boat Davit Supports (Port) | 75. Vent Grills (Port Funnel) | 101. Vent Grill (02 Deck Stbd Fwd) |
| 51. Landing Craft Davits | 76. Sea King Helicopter Rotor (Folded) | 102. Funnel Cap Grills |
| 52. Landing Craft Davit Supports | 77. Sea King Helicopter Rotor (Spread) | 103. Sea Cat Launcher Rails |
| 53. Landing Craft Davit Falls | 78. Sea King Helicopter Personnel Door | 104. Sea Cat Missiles |
| 54. Quarterdeck Crane Rest | 79. Sea King Helicopter Tail Rotor | 105. Sword & Shield Antennas |
| 55. Flight Deck Crane Jib (Intrepid) | 80. Sea King Helicopter Cargo Door | 106. Yardarms (Main Mast Lower) |
| 56. Flight Deck Crane Jib (Fearless) | 81. Sea King Helicopter Sponson Struts | 107. Yardarms (Main Mast Mid) |
| 57. Forward 02 Deck Platforms | 82. Sea King Helicopter FOD Guard | 108. Vent Grills (Stbd Side) |
| 58. Forward 01 Deck Platforms | 83. Life Raft Platforms 01.5 Deck | 109. Bridge Front DF Antenna |
| 59. Accommodation Ladder Railings | 84. Life Raft Platform Supports | 110. Vent Grills (Port Side) |
| 60. Accommodation Ladder (Upper) | 85. 182 Decoy Crane Jib | 111. Yardarm Stays (Main Mast Upper) |
| 61. Accommodation Ladder (Lower) | 86. Stern Door Support Plates | 112. Yardarms (Main Mast Upper) |
| 62. Accommodation Ladder (Fixed) | 87. Stern Door Supports | 113. Binocular Sites |
| 63. Vent Grill (Stbd Funnel) | 88. Kedge Anchor Stowage Frames | 114. Vent Grills (01 Deck Fwd) |
| 64. Quarterdeck Crane Jib (Intrepid) | 89. Kedge Anchors | 115. Signal Lamps (Large) |
| 65. Crane Hook | 90. Wire Antenna Spreader | 116. Bridge Wing Front Brackets |
| 66. Quarterdeck Crane Job (Fearless) | 91. Yardarm Stays (Fore Mast Sides) | 117. Flight Deck Flood Light Bases |
| 67. Wessex Helicopter Rotor (Folded) | 92. Yardarms (Fore Mast Sides) | 118. Ships Name Plates |
| 68. Wessex Helicopter Rotor (Spread) | 93. Formast Yardarm Top Frame | 119. Life Raft Racks (Triple) |
| 69. Vent Grill (04 Deck Fwd) | 94. Yardarms (Fore Mast Front Quarter) | 120. Life Raft Racks (Double) |
| 70. Wessex Helicopter Tail Rotor | 95. Yardarms (Fore Mast Footbars) | 121. Life Raft Racks (Single) |
| | 96. Yardarms (Main Mast Top Aft) | |

Resin Parts

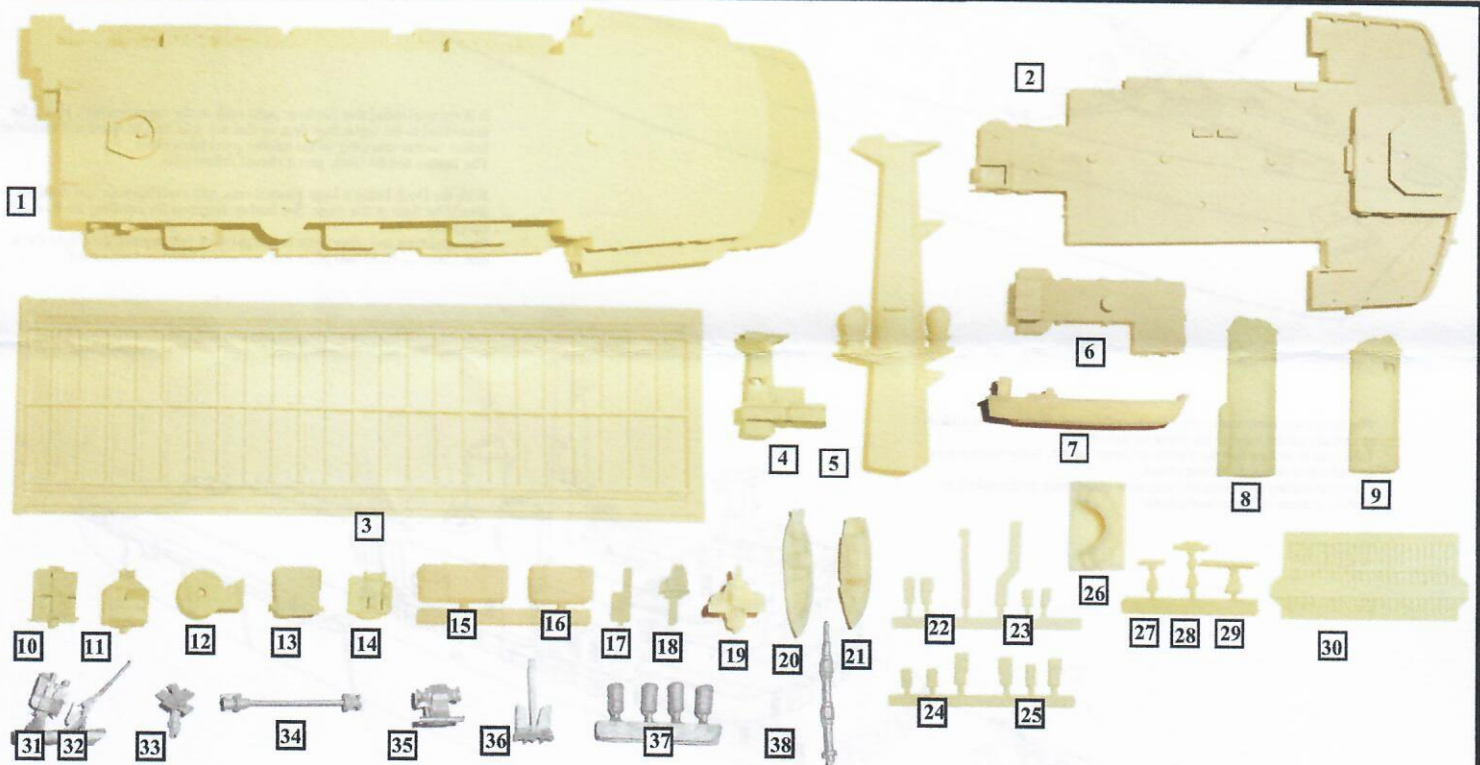

- | | | | |
|----------------------------------|----------------------------------|---------------------------------|--------------------------------|
| 1. Main Superstructure | 11. Flight Deck Crane (Intrepid) | 21. 25' Cheverton Motor Boat | 31. 40mm Bofors Base x 2 |
| 2. Bridge and 04 Deck | 12. Flight Deck Crane Base | 22. Vent Trunking (Stbd Aft) | 32. 40mm Bofors Guns x 2 |
| 3. Flight Deck Plate | 13. Flight Deck Crew Shelter | 23. Vent Trunking (Stbd Fwd) | 33. Corvus Chaff Launchers x 2 |
| 4. Fore Mast and GDP | 14. Quarterdeck Crane | 24. Vent Trunking (Port Fwd) | 34. LCVP Davit Mechanism x 4 |
| 5. Main Mast | 15. Portacabin (Port) | 25. Vent Trunking (Port Aft) | 35. Quarterdeck Decoy Winch |
| 6. Comms House | 16. Portacabin (Stbd) | 26. Chaff Launcher Enclosure x2 | 36. Anchors x 2 |
| 7. LCVP x 4 | 17. Cage Aerial Base | 27. 1006 Nav Radar Antenna | 37. Life Raft Canisters x 69 |
| 8. Port Funnel | 18. Sea Cat Director x 4 | 28. IFF Antenna | 38. Main Mast Top Pole Array |
| 9. Stbd Funnel | 19. Sea Cat Launcher x 4 | 29. 993 Radar Antenna | |
| 10. Flight Deck Crane (Fearless) | 20. 27' Motor Whaler | 30. Stern Dock Gate | |

Main Parts Location

It is advisable to read through these instructions thoroughly before attempting any assembly sequences, so as to fully acquaint ones self with the form of the parts and method involved.

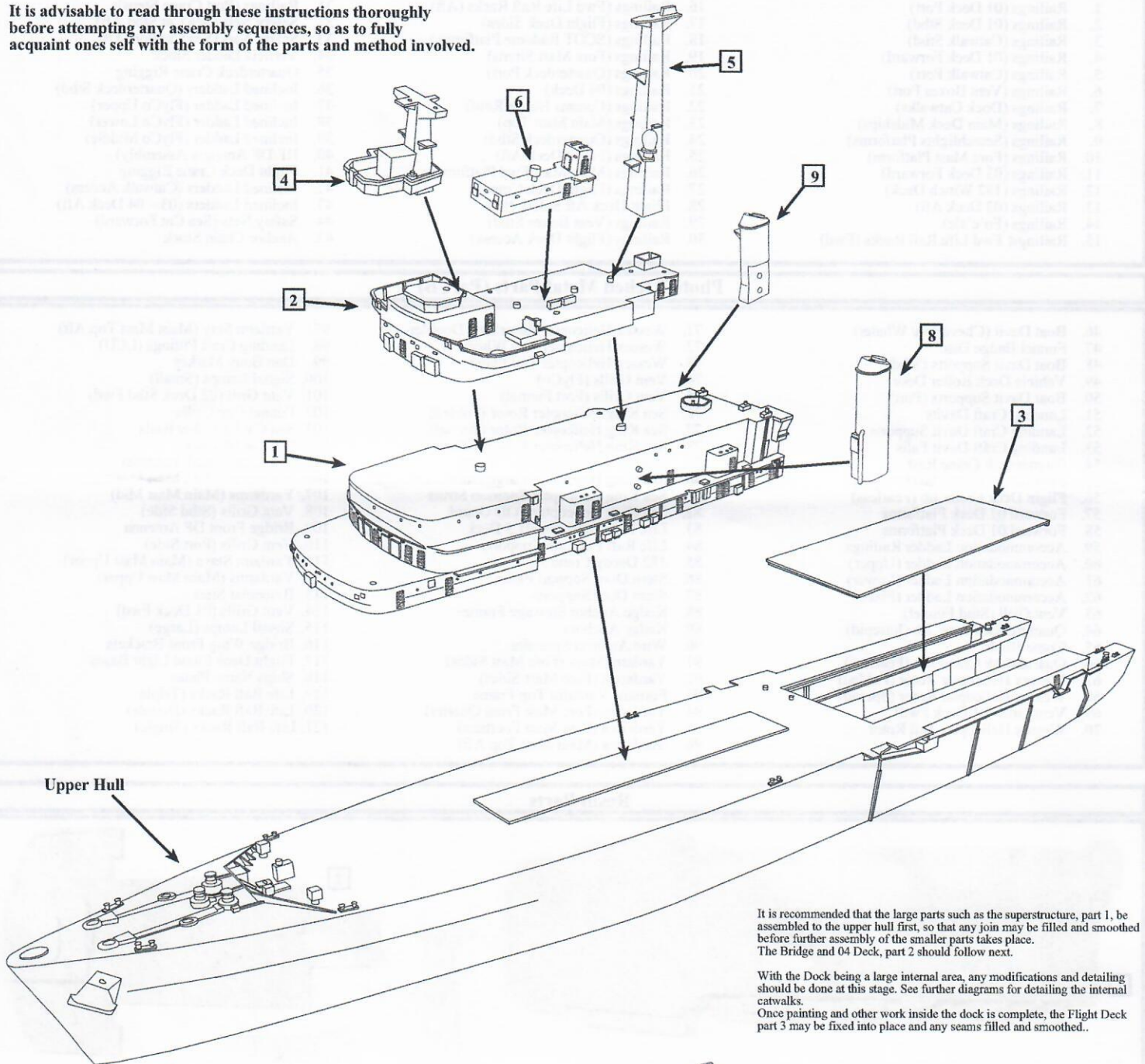

It is recommended that the large parts such as the superstructure, part 1, be assembled to the upper hull first, so that any join may be filled and smoothed before further assembly of the smaller parts takes place. The Bridge and 04 Deck, part 2 should follow next.

With the Dock being a large internal area, any modifications and detailing should be done at this stage. See further diagrams for detailing the internal catwalks.

Once painting and other work inside the dock is complete, the Flight Deck part 3 may be fixed into place and any seams filled and smoothed..

The remaining parts such as the masts and funnels may now be added so that the model reaches the stage as shown right. Take care to ensure that the Comm's House, part 6, is the correct way around when fitting as shown above. Further detailing and assembly may now commence as described in further sections of these instructions.

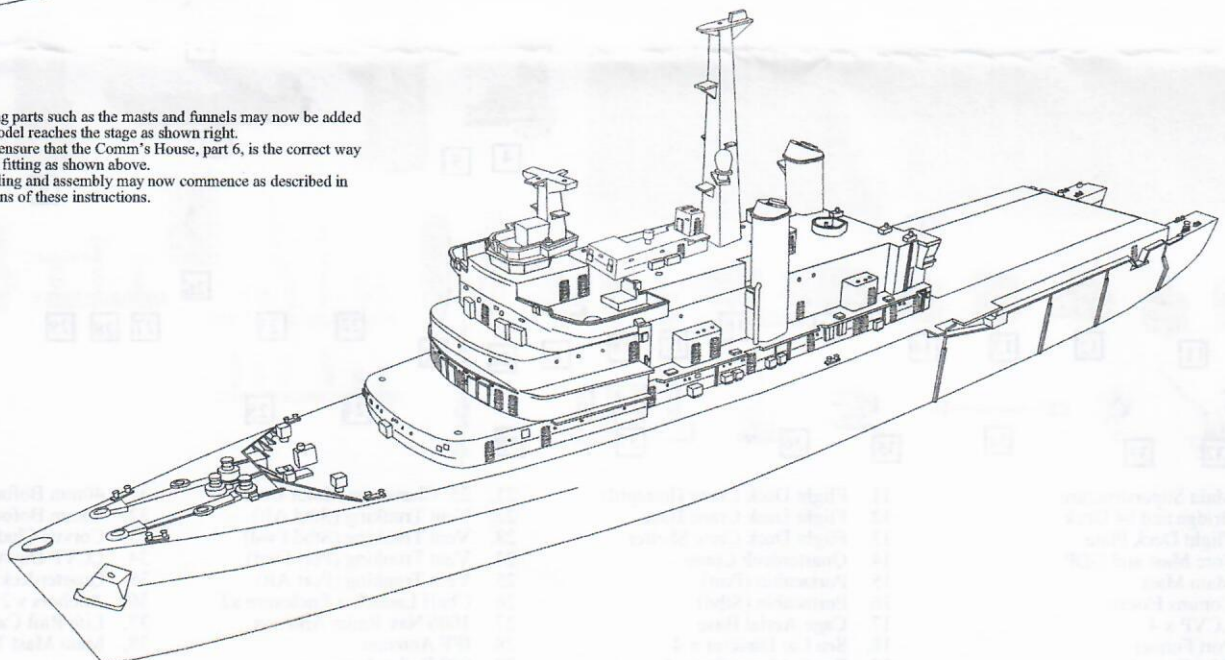

Sea Cat Missile Launcher

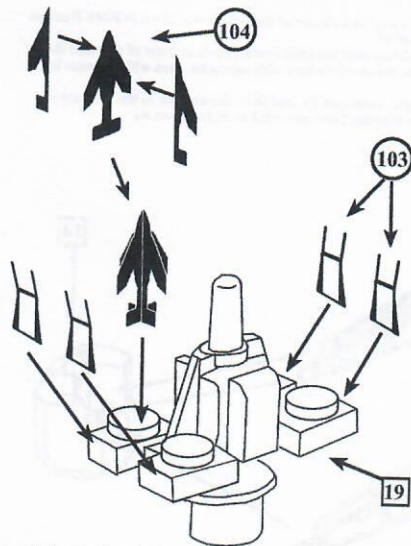

Assemble the Sea Cat missiles using etched parts 104 as shown above. These can be fitted to the launcher as desired. Fit the side rails, etched parts 103, to the short sides of the launcher.

40 mm Bofors Gun Mounting

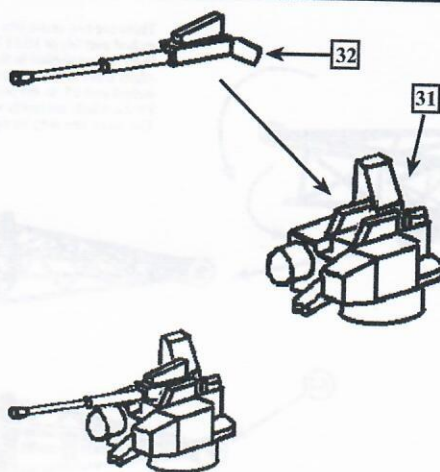

Fit the body of the 40mm Bofors gun, part 32, into the recess on the top of the Gun Mounting, part 31. The gun may be set at any desired angle of elevation before securing into place. Make 2 of these. Fit into place on the raised locating discs provided on the decks of the bridge wings.

Corvus Chaff Launcher Assembly

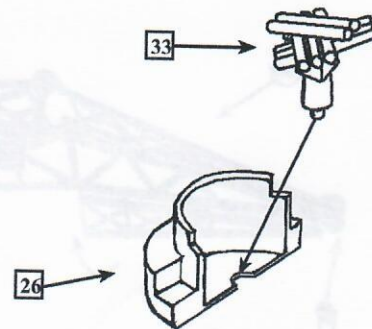

It is recommended that the Corvus Chaff Launcher enclosures be fitted to the deck on each side of the bridge wings before fitting the launcher. See later diagram for exact location. Cut out a rectangular notch in the bottom of the enclosure to receive the base of the launcher.

Life Ring Ejectors

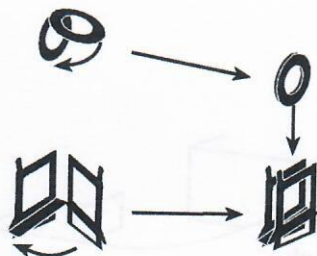

Fold the sides of the Life Ring Ejector around so that they are parallel. Twist up the central spacer so that the edges locate along the bottom rail on the two sides. Fix into place. Fold the life rings, in half so that they are double thickness, then place inside the ejector rack after painting.

Life Raft Canister Assembly

Fold up the sides of the life raft canister holders, to 90° as shown right so that they are parallel. This method is the same for all the canister holders provided. Note that the single canister holders have a hooked forward lower edge. This is so that they overhang the edges of the catwalks equally.

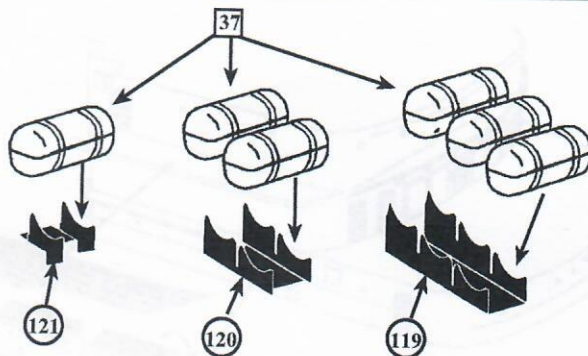

Mast Head DF Antenna

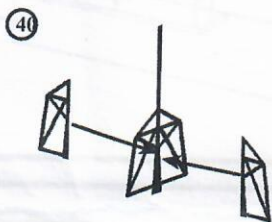

Assemble the mast top HF/DF Antenna, etched parts 52, so that the vertical pillars on the half frames fit onto the vertical centre pillar of the full frame on each side at 90°. This antenna fits to the top of the main mast antenna pole.

Dan Buoy Assembly

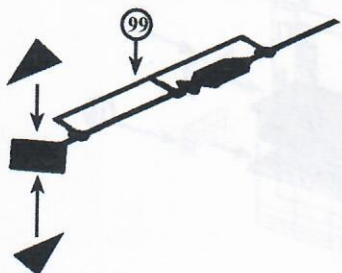

Assemble the radar reflectors on the Dan Buoys, etched parts 100, as shown above. Fit the rectangular bracket arrangement onto the side railings on each stern quarter. The colour of the reflector and body of the Dan Buoys varied from Dayglo Orange which was the most common, to Red and White 90° alternate sections.

Flight Deck Crane Assemblies

HMS Fearless Flight Deck Crane

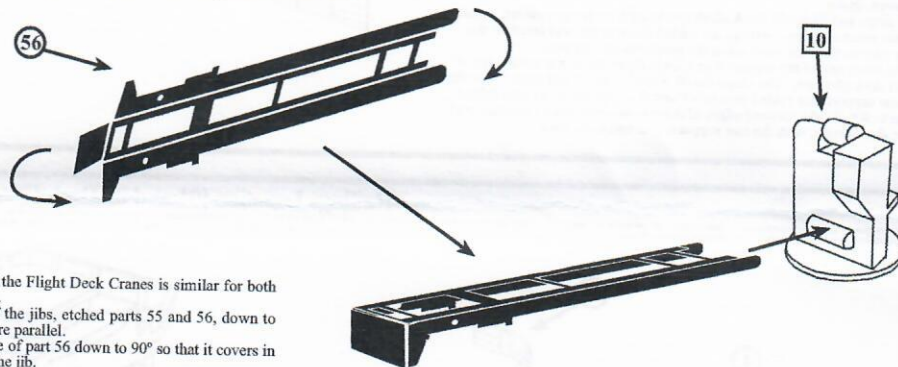

The assembly of the Flight Deck Cranes is similar for both ships of the class. Fold the sides of the jibs, etched parts 55 and 56, down to 90° so that they are parallel. Fold the end plate of part 56 down to 90° so that it covers in the outer end of the jib. Fold the bottom frame of etched part 55 around a further 90° so that the outer edge fits against the lower edge of the far side plate. Open the legs of the part 55 as shown below so that they fit onto the parallel sides of the crane cab.

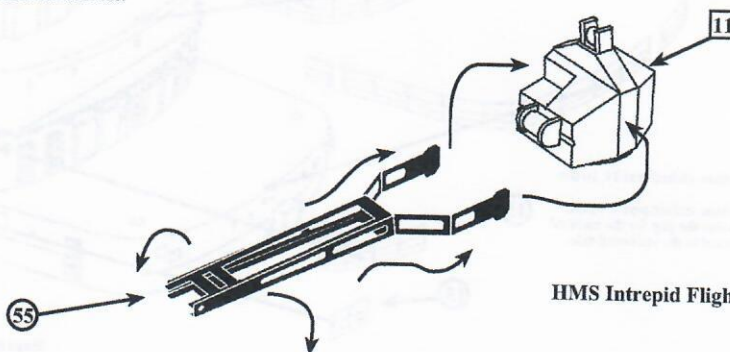

HMS Intrepid Flight Deck Crane

Quarterdeck Crane Assembly

There are two crane jibs supplied in this kit to give a choice of that which was fitted to HMS Fearless etched part 66, or HMS Intrepid etched part 64. Both are assembled in the same way by folding over the latticework panels in steps of 90° until the far edges meet to form an enclosed box lattice. Secure the edges with superglue, then add the crane hook etched part 65, to the outer end location. Fit the whole assembly to the crane cab base, resin part 14, and fit as shown later in the instructions. The crane jibs may be rigged by using the Rigging Lines provided as etched parts 41.

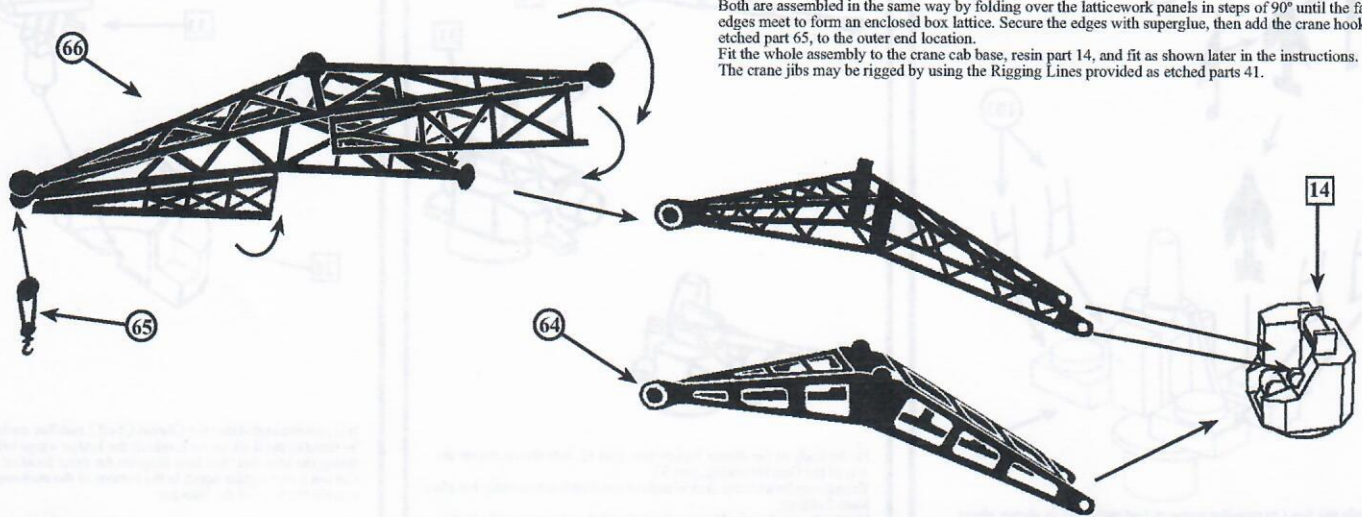

Forward Life Raft Platforms

Fit the 03 Deck platform, etched part 57, to the resin extension on the side of the superstructure as shown below left. Once in position this platform should rest on top of the upper rail on etched part 84. This diagram shows the assembly of the Port Side platforms. The Starboard Side platforms are assembled in the same way only a mirrored image.

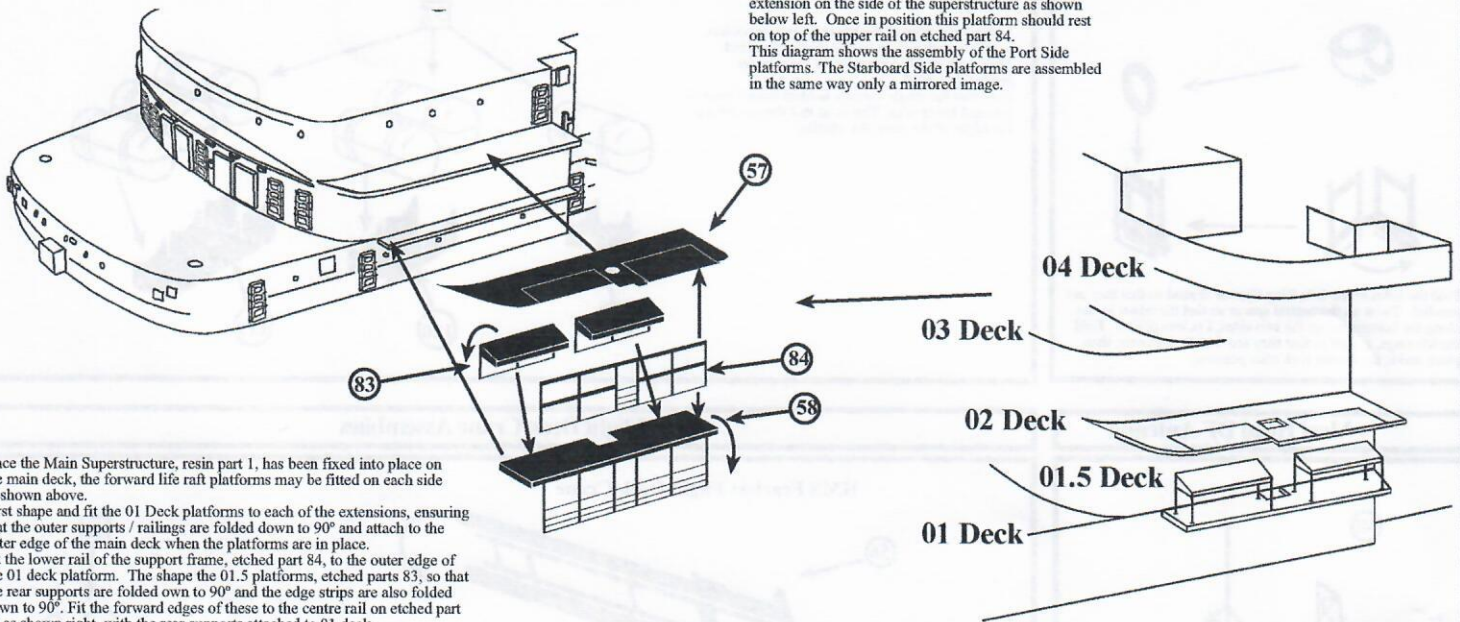

Once the Main Superstructure, resin part 1, has been fixed into place on the main deck, the forward life raft platforms may be fitted on each side as shown above. First shape and fit the 01 Deck platforms to each of the extensions, ensuring that the outer supports / railings are folded down to 90° and attach to the outer edge of the main deck when the platforms are in place. Fit the lower rail of the support frame, etched part 84, to the outer edge of the 01 deck platform. The shape the 01.5 platforms, etched parts 83, so that the rear supports are folded down to 90° and the edge strips are also folded down to 90°. Fit the forward edges of these to the centre rail on etched part 84 as shown right, with the rear supports attached to 01 deck.

Railings Location (01 and 03 Deck Forward)

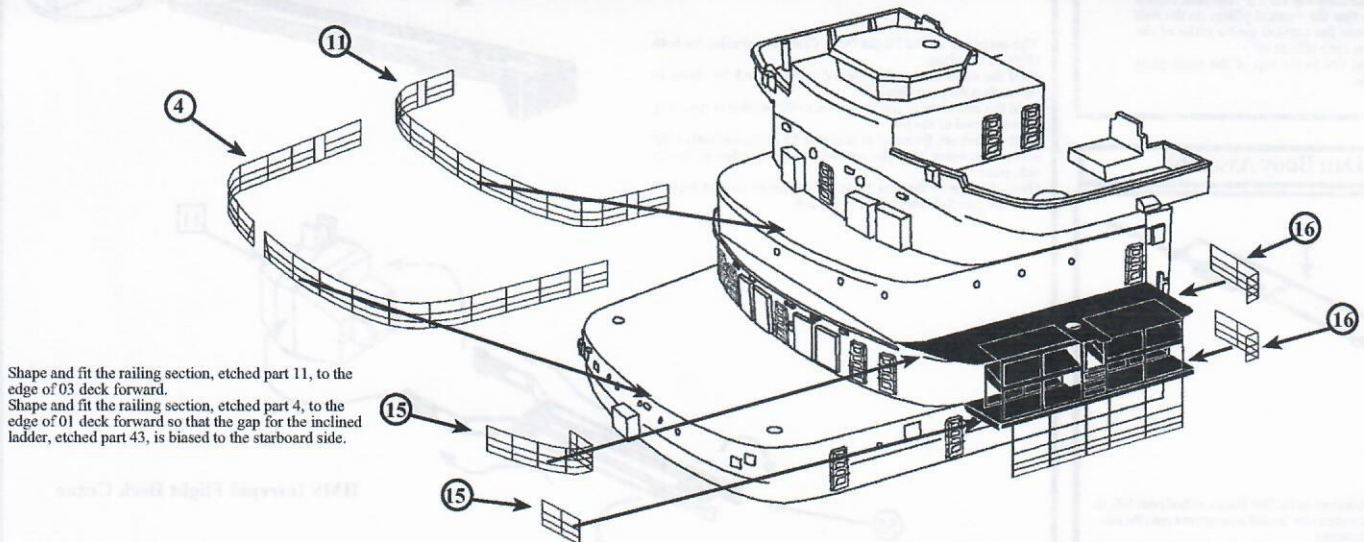

Shape and fit the railing section, etched part 11, to the edge of 03 deck forward. Shape and fit the railing section, etched part 4, to the edge of 01 deck forward so that the gap for the inclined ladder, etched part 43, is biased to the starboard side.

Shape the small railing sections, etched parts 15 and 16 to fit the forward and aft edges of the life raft canister platforms on both sides as shown above.

Fo'c'sle Fittings and Railing Location

Shape the railings sections, etched parts 14 to fit the edges of the fo'c'sle deck as shown below. The aft stanchion of these sections should fit against the first support post of the life raft platforms.

Drill out the hawse pipe holes from the anchor recesses on each side of the bow, using a 1.5mm drill bit, to allow the anchors, metal parts 36, to fit flush into the recesses.

Fit two of the Sea Cat Launcher Assemblies to the locating holes at the front of 01 deck.

Note: The railings immediately adjacent to the Sea Cat Launchers may be cut away and replaced with Safety Nets, etched parts 44, if desired.

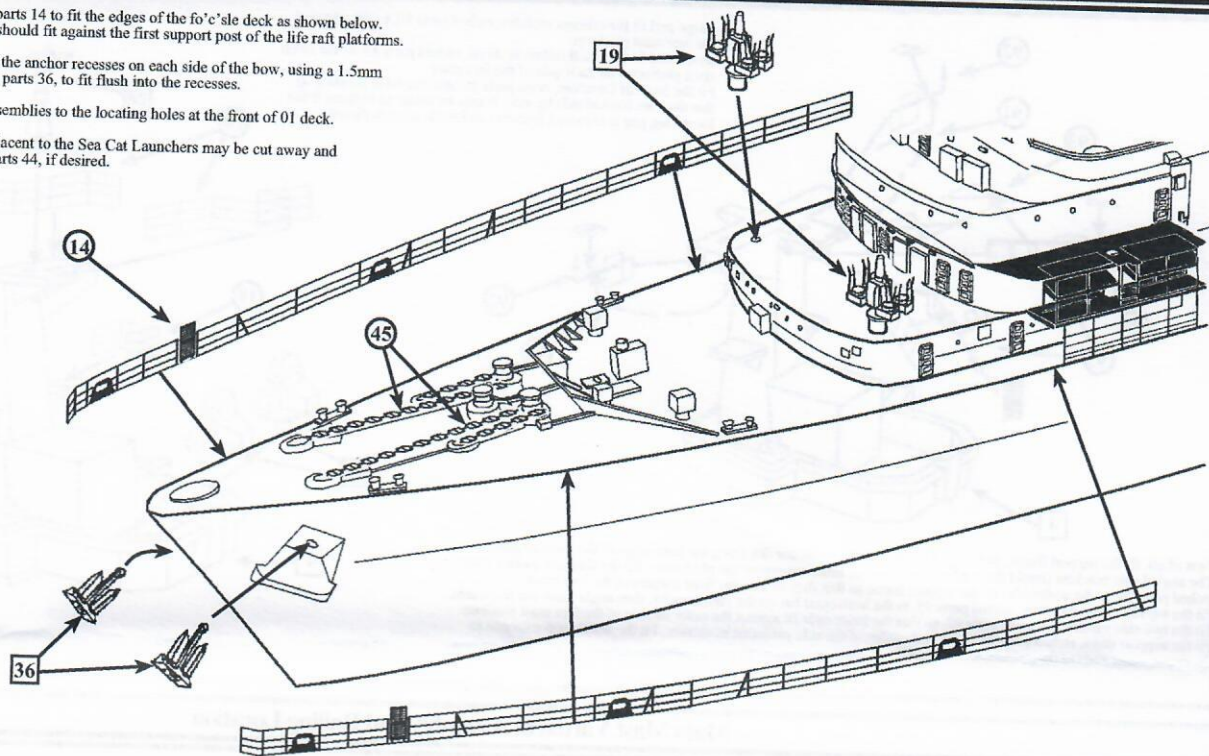

Railing Location (04 Deck and Comms House Roof)

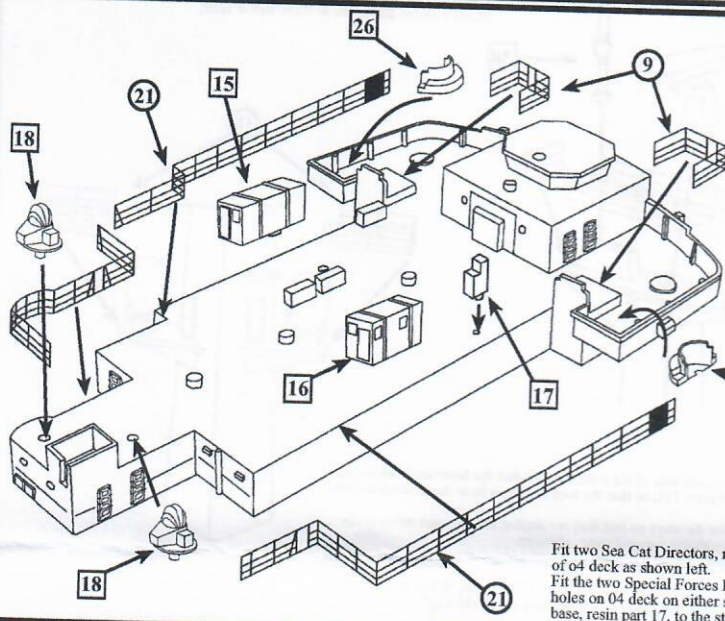

Shape and fit the railings sections, etched parts 21, to the edges of 04 deck as shown left. Shape and fit the small railing sections, etched parts 9 to the Searchlight Platforms.

Fit the Corvus Chaff Launcher Enclosures, resin parts 26, to each side of the bridge wings, outboard of the Searchlight Platforms. Once these are secured in place, the Chaff Launchers, metal parts 33, may be fitted into the enclosures as shown in an earlier diagram.

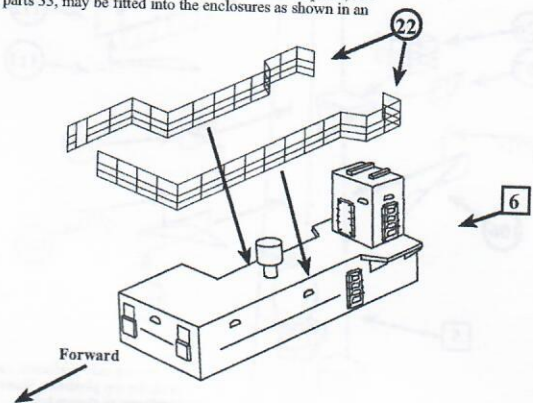

Shape and fit the railings sections, etched parts 22, to the edges of the Comm's House roof as shown above.

Fit two Sea Cat Directors, resin parts 18 into the locating holes at the rear of 04 deck as shown left. Fit the two Special Forces Portacabins, resin parts 15 and 16 to the locating holes on 04 deck on either side of the Comm's house. Fit the wire antenna base, resin part 17, to the starboard side of 04 deck.

Bridge Wing Fittings

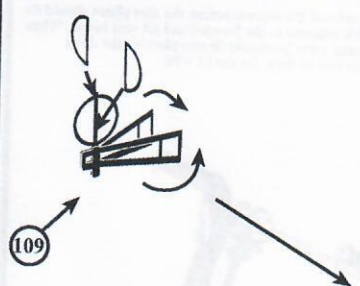

Fold the two legs of the DF Antenna bracket around to form a V when viewed from above. Pinch the forward end together and secure into place. Fit the two side half loops to the vertical bar as shown left. Fit the complete assembly centrally to the bridge front below the lower set of windows.

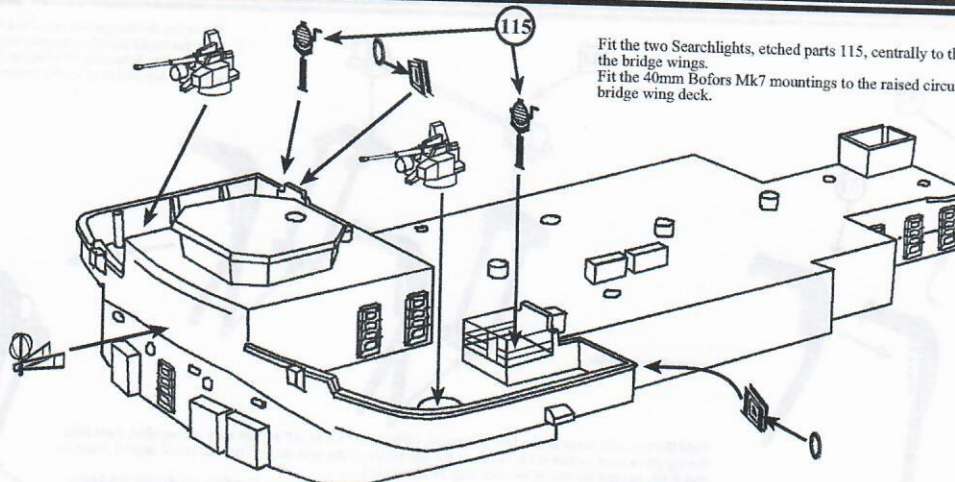

Fit the two Searchlights, etched parts 115, centrally to the platforms on the bridge wings. Fit the 40mm Bofors MK7 mountings to the raised circular discs on the bridge wing deck.

Fit the life ring ejector racks to the outsides of the rear bridge wing bulwarks

Fore Mast Yardarm Assembly and Railing Location

Shape and fit the railings sections, etched parts 10, to the edges of the fore mast platform.
Shape and fit the small railing sections, etched parts 19, to the small siren platforms on each side of the fore mast.
Fit the Sea Cat Directors, resin parts 18, into the GDP position so that they are located side by side. It may be easier to fit them if the locating peg is removed from the underside of each director.

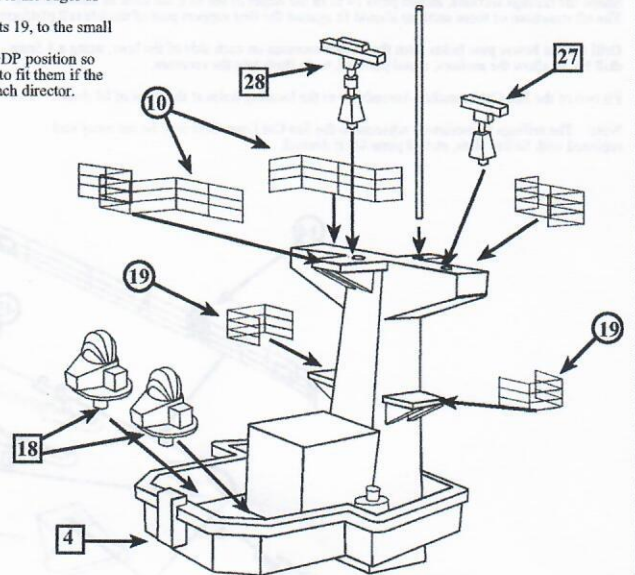
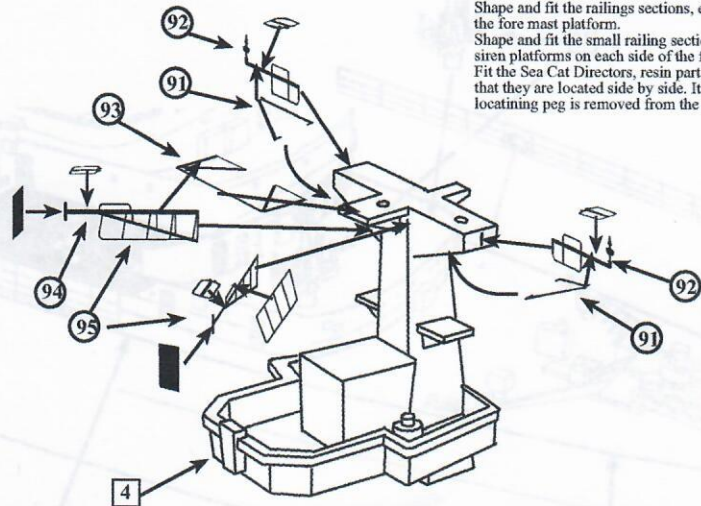

First of all, fit the support frame, etched part 93, so that the cross bar fits along the front edge of the forward platform. The angled side brackets should then radiate out from the inner corners of the platforms. Fit the forward quarter yards etched parts 94, to the undersides of the support frame so that they fit into the front corners of the fore mast. Fit the top rail of the foot bars, etched parts 95, to the horizontal bar on the yardarms 94, then angle them out rearwards. Fit the two side yardarms, etched parts 92, so that the inner ends fit against the outer surface of the fore mast platform. Fit the support stays, etched parts 91 to the undersides of the side yardarms as shown. Fit the small loop antennas to the upper, outer ends of the yardarms.

Main Mast Yardarm Assembly and Railing Location

Shape and fit the railings section, etched part 23, to the edges of the main mast top platform as shown below left. Fit the 993 Radar Antenna, resin part 29, to the locating hole at the front of the mast top platform. Fit the Pole Antenna, metal part 38, to the raised box section at the rear of the mast top platform.
Shape and fit the railings sections, etched parts 18, to the edges of the SCOT radome platforms as shown below right.

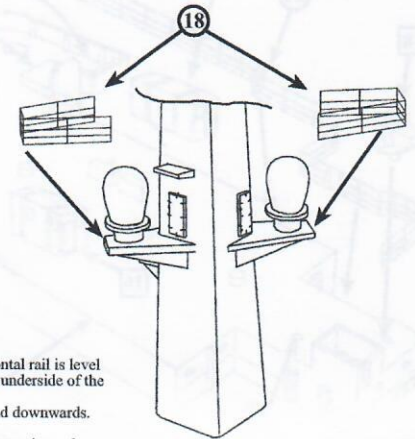
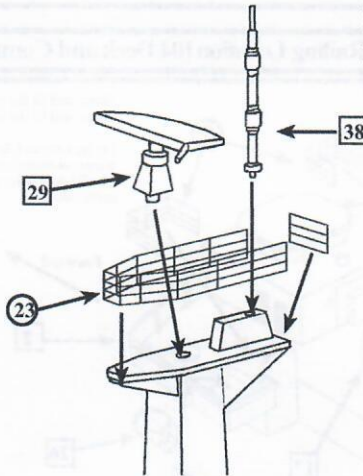
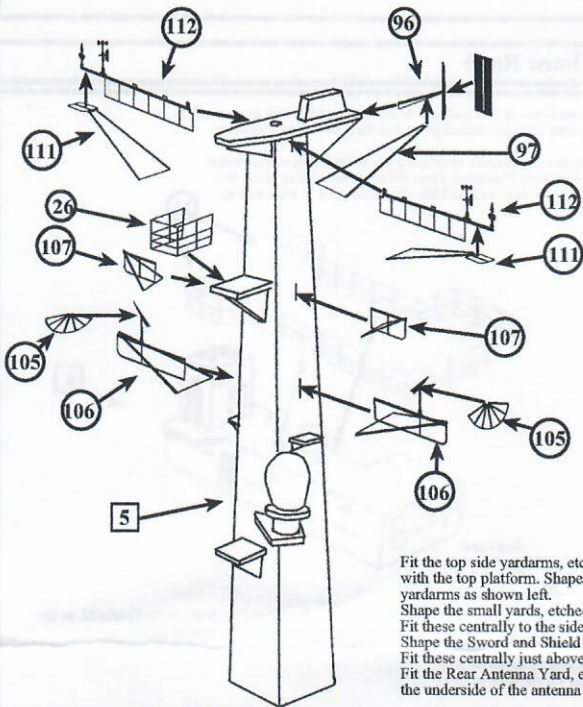

Fit the top side yardarms, etched parts 112, centrally to each side of the main mast so that the horizontal rail is level with the top platform. Shape the yardarm stays, etched parts 111, so that the loop antennas fit to the underside of the yardarms as shown left.
Shape the small yards, etched parts 107, by folding over the stays so that they are angled inwards and downwards.
Fit these centrally to the sides of the main mast, level with the forward upper platform.
Shape the Sword and Shield Antenna Yards, etched parts 106, in the same way by folding the stays over inwards.
Fit these centrally just above the small side platforms.
Fit the Rear Antenna Yard, etched part 96, centrally to the rear of the top platform. Fit the stay, etched part 97 to the underside of the antenna so that the inner end fits to the rear face of the mast, just below the angle.

LCVP Davit Assembly

When the davit supports are fitted to the sides of the superstructure, the foot plates should fix onto the raised rectangles on 01 deck adjacent to the forward and aft vent boxes. When in place the Actuating Mechanism bar, metal parts 34 should fit into place on the davit supports top plates as shown centre. Make four of these for the LCVPs.

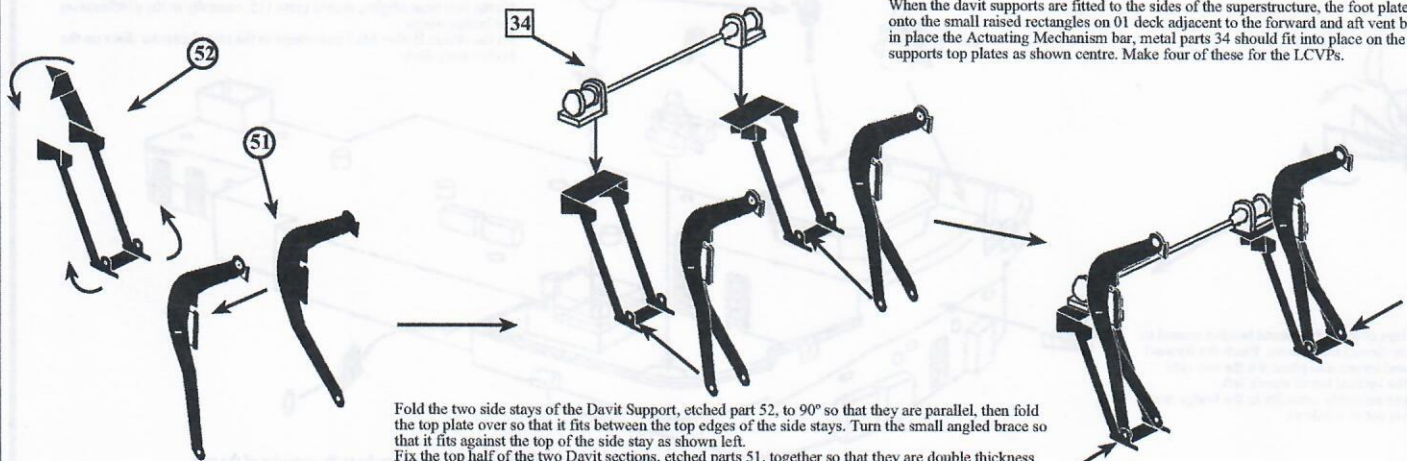

Fold the two side stays of the Davit Support, etched part 52, to 90° so that they are parallel, then fold the top plate over so that it fits between the top edges of the side stays. Turn the small angled brace so that it fits against the top of the side stay as shown left.
Fix the top half of the two Davit sections, etched parts 51, together so that they are double thickness but open the lower legs apart so that the feet fit inside the foot plate of the support stays. A wire hinge may be fed through the holes in the foot plate so that the davits may be set at an angle when fitted.

Ships Boats Davit Assembly

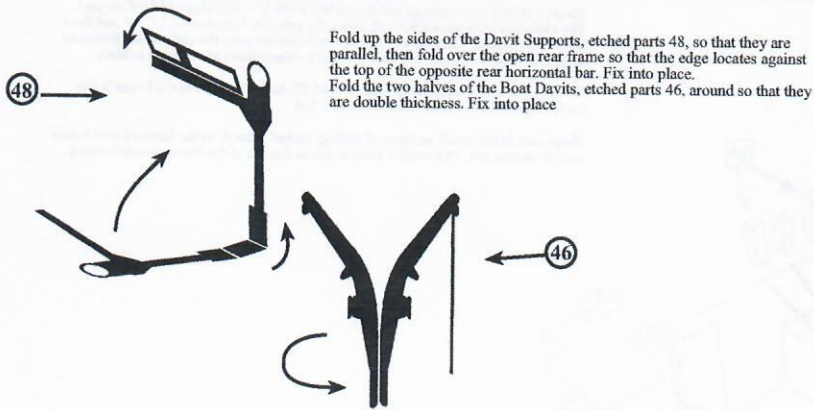

Fold up the sides of the Davit Supports, etched parts 48, so that they are parallel, then fold over the open rear frame so that the edge locates against the top of the opposite rear horizontal bar. Fix into place. Fold the two halves of the Boat Davits, etched parts 46, around so that they are double thickness. Fix into place.

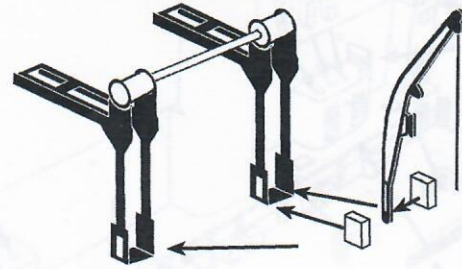

Cut small rectangular packers from plastic strip to locate the feet of the davits into place in the support frames. The davits can be fitted with boats stowed or deployed by angling the position to suit, keeping them parallel. Stretched sprue or Caenis thread may be used to rig the davits from the top of each, back to the cable drums. Do not remove the etched metal falls as they will be required to fit the boats into place.

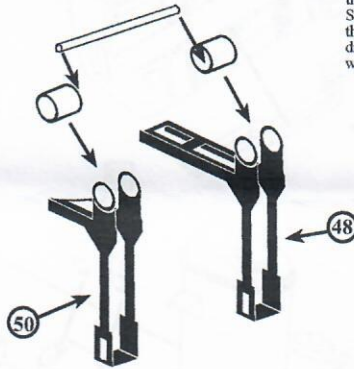
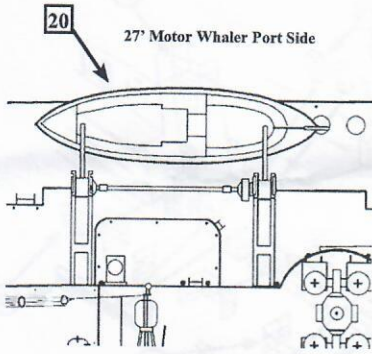

Using 2mm diameter plastic rod, cut two lengths to fit in between the tops of each davit support forming the cable drum for the boat falls. Measure out two joiner link bars 13.5mm long, that fit in between the two cable drums, making them from 0.75mm (30 thou) plastic rod. The foot plates of each davit fit onto 01 decks port and starboard at the locations shown in the diagrams on the left. The inner ends of the horizontal frames fit against the sides of the superstructure, except for the port forward davit that holds the Cheverton Motor Boat. This support frame is shaped to fit around the forward face of the port funnel and the etched part is unique and shown in the assembly diagram above in the form it should take.

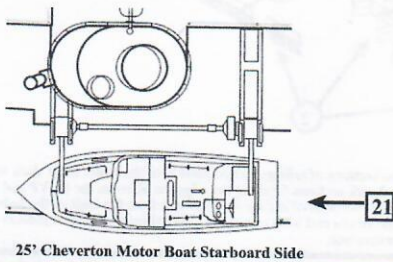

LCVP Assembly and Davit Location

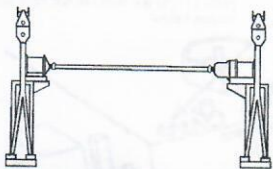

Fit the LCVP Davits to the small rectangular raised moldings in the deck on each side of the vent boxes, fore and aft as shown below. Fit the falls, etched parts 53, to the tops of the davits and ensure they are secure before fitting the LCVP's into place. This is done by twisting the falls so they are athwartships over the LCVP, they passing each LCVP up inside the falls until the desired height is reached. Tack the falls into place at the points shown on the sides of the LCVP then trim to length using a sharp blade.

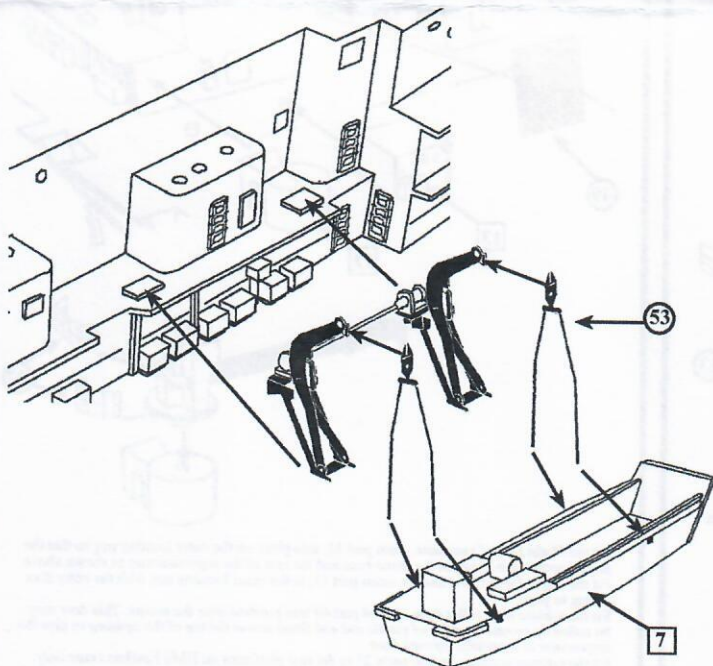

Ships Boats Davit Location

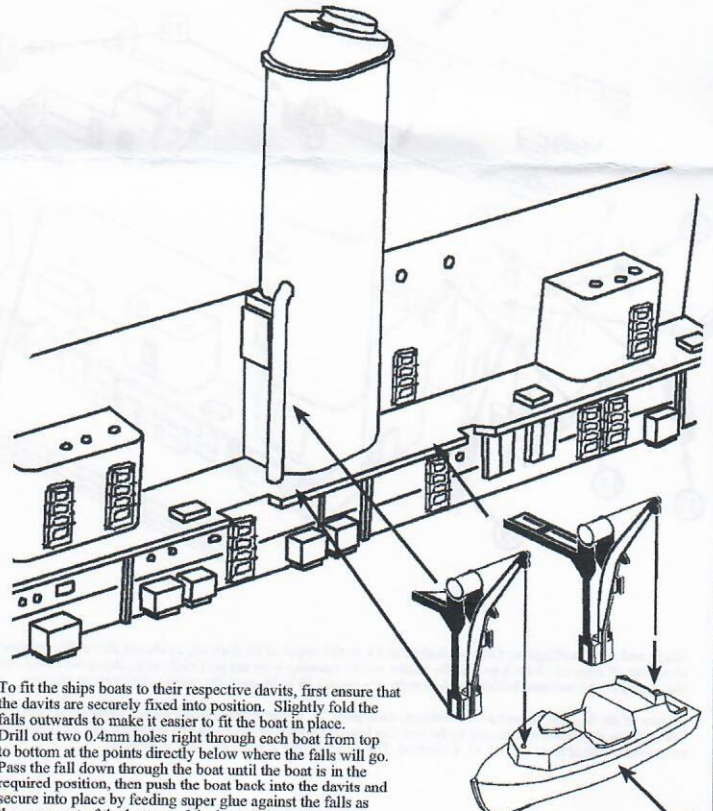

To fit the ships boats to their respective davits, first ensure that the davits are securely fixed into position. Slightly fold the falls outwards to make it easier to fit the boat in place. Drill out two 0.4mm holes right through each boat from top to bottom at the points directly below where the falls will go. Pass the fall down through the boat until the boat is in the required position, then push the boat back into the davits and secure into place by feeding super glue against the falls as they pass out of the bottom of the boat. Trim to length.

Ventilator Trunks and Railings Location (01 Deck Aft)

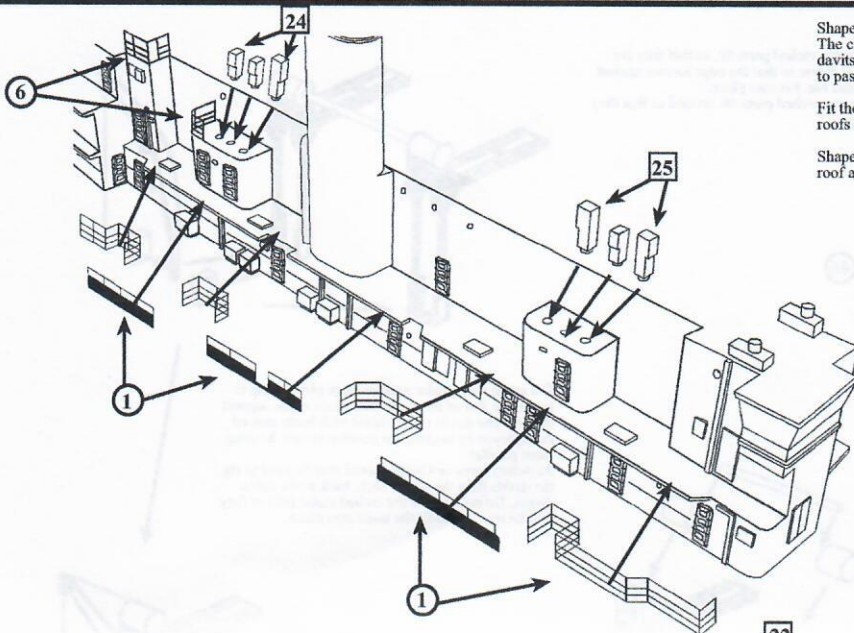

Shape and fit the sections of railing, etched parts 1, to the edges of 01 deck port. The closed in bulwark sections fit along the edges in between the LCVF and Boat davits. The smaller sections of railing feed inboard from the ends of the bulwarks to pass behind the davits and back around to where there are vertical ladders.

Fit the ventilator trunks, resin parts 24 and 25, to the forward and aft vent house roofs respectively. Locate these as shown left.

Shape and fit the small sections of railing, etched parts 6, to the forward vent house roof as shown left. The smaller section fits to the top of the forward vent conduit.

Fit the ventilator trunks, resin parts 22 and 23, to the aft and forward vent house roofs respectively. Locate these as shown right.

Shape and fit the small sections of railing, etched parts 29, to the forward and centre vent house roofs as shown left. The smaller section fits to the top of the forward vent conduit.

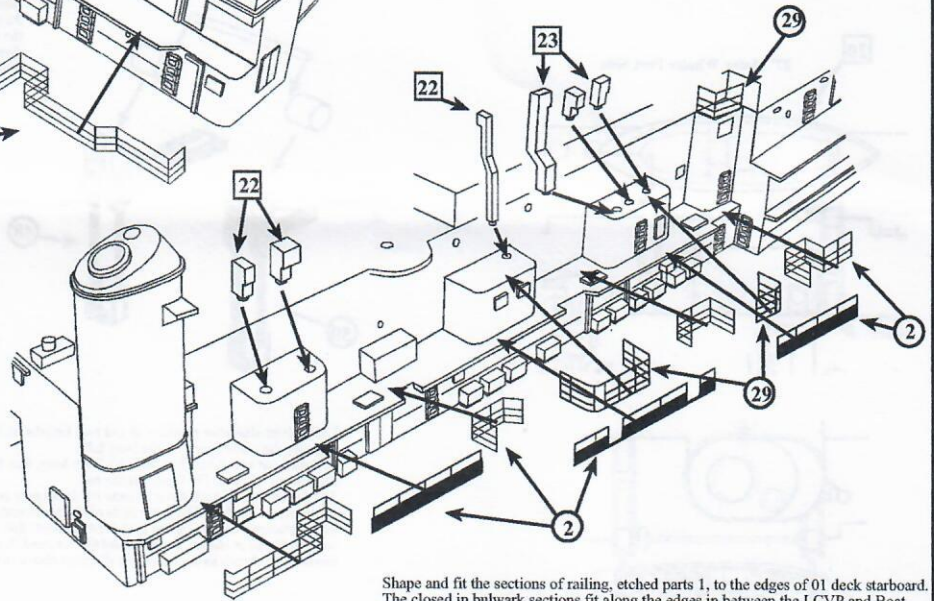

Shape and fit the sections of railing, etched parts 1, to the edges of 01 deck starboard. The closed in bulwark sections fit along the edges in between the LCVF and Boat davits. The smaller sections of railing feed inboard from the ends of the bulwarks to pass behind the davits and back around to where there are vertical ladders up the side of the superstructure.

Railings Location (03 Deck Aft)

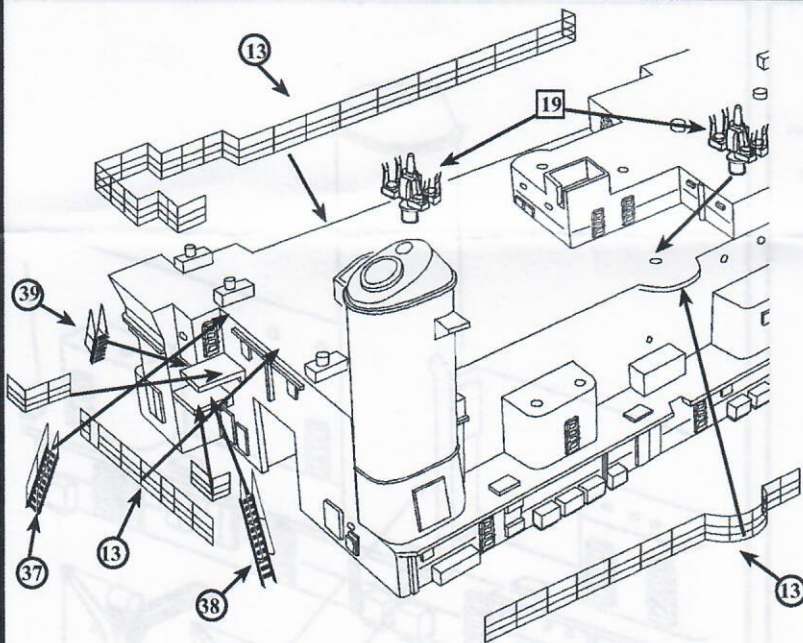

Shape and fit the railings sections, etched parts 13, to the edges of 03 deck aft, as shown above. Fit the shorter length along the aft edge of 03 deck so that the ladder access opening is on the port (left) side, above the Flyco entry platform. Shape and fit the inclined ladders, etched parts 37, 38 and 39 to fit on to the access platforms as shown.

Fit two of the Sea Cat Launcher Assemblies, resin parts 19, to the locating holes on each side of 03 deck. Note : The railings immediately adjacent to the Sea Cat launchers may be cut away and replaced with the retractable safety nets, etched parts 32 and 33, if desired. The larger fitting around the deck extension.

Flight Deck Crane and Crew Shelter Location

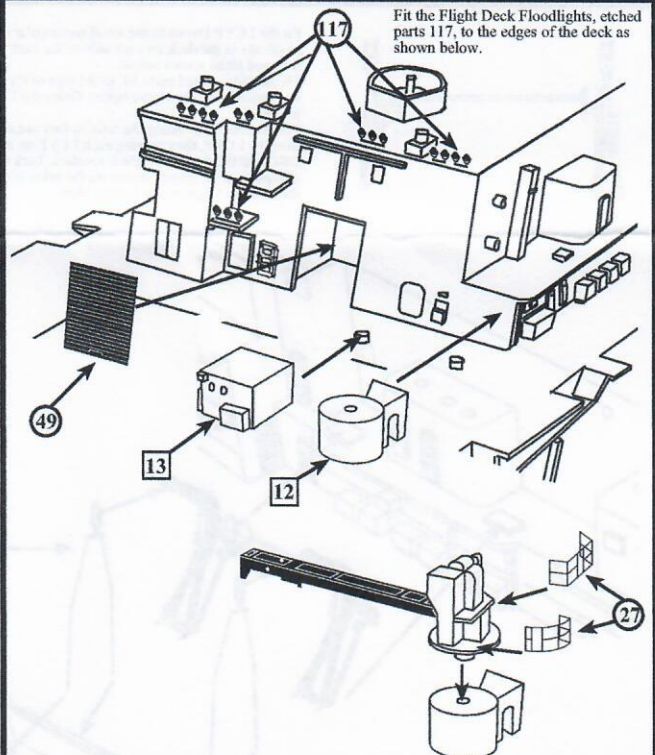

Fit the Flight Deck Floodlights, etched parts 117, to the edges of the deck as shown below.

Fit the Flight Deck Crane base, resin part 12, into place on the outer locating peg so that the angled archway is between the crane base and the rear of the superstructure as shown above. Fit the Flight Deck Crew Shelter, resin part 13, to the inner locating peg with the entry door facing to port. Fit the vehicle deck roller door, etched part 49 into position over the access. This door may be rolled up around a length of plastic rod and fitted across the top of the opening to give the impression of a partially opened door. Fit the railings sections, etched parts 27 to the rear platforms on HMS Fearless crane only. Fit the crane assembly on to the base in the position required

Railings Location (Dock and Starboard Catwalks)

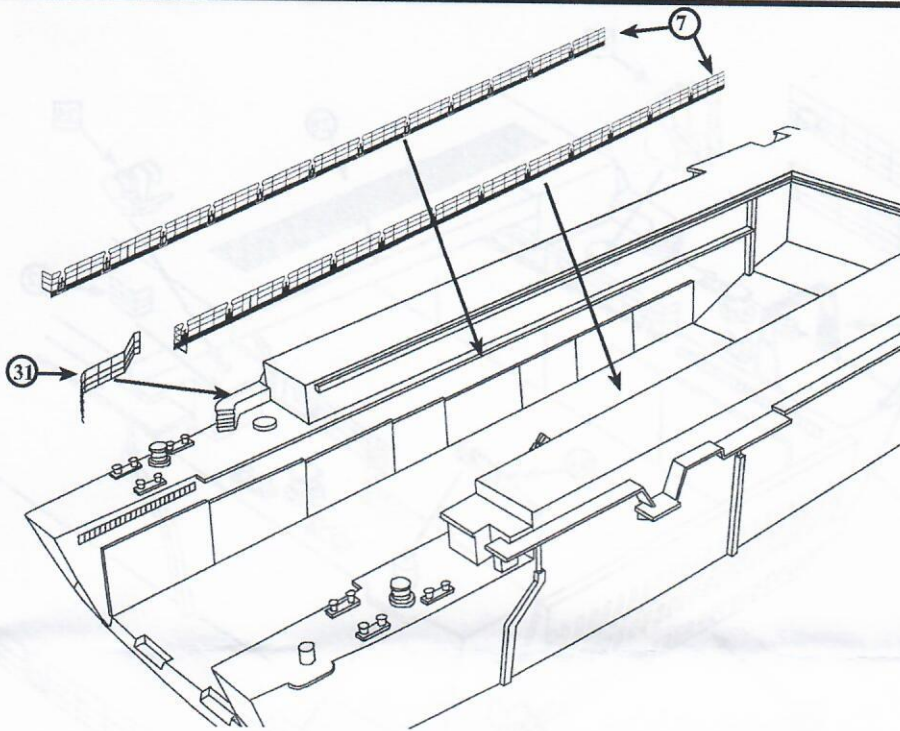

Fit the railings sections, etched parts 7, to the edges of the internal dock catwalks. Turn the aft ends of the railings outboard to 90° to cover the aft ends of the catwalks. These catwalk railings have stags head mooring points along the length that are numbered 1 to 12 from forward to aft on each side. Please note that these railings sections are mirrored to fit on each side of the dock. The top sections of railing may be angled outwards towards the dock if desired.

Shape and fit the small railing section, etched part 31, to fit outboard of the access steps on the port side quarterdeck.

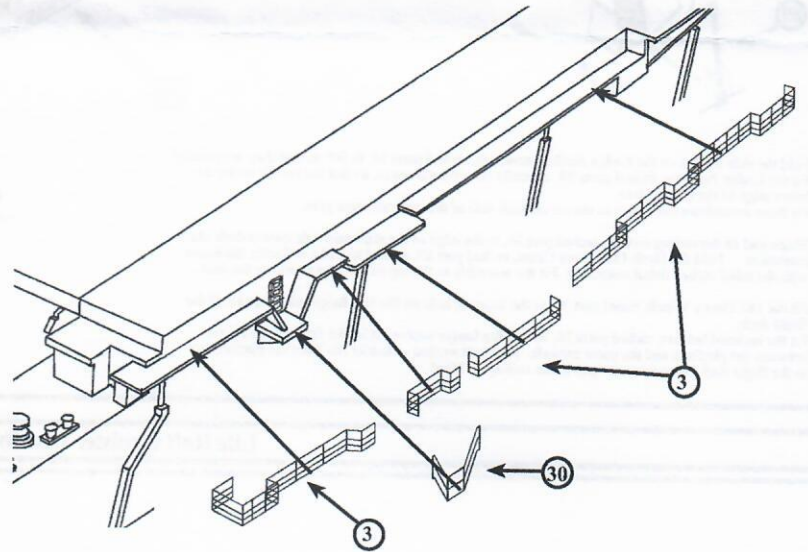

Shape and fit the sections of railing, etched parts 3, to the three edges of the starboard flight deck catwalk. The shape includes recesses for the positioning of lengths of life raft canister racks that will be shown in a further diagram.

Railings Location (Flight Deck and Port Catwalk)

Railings as provided with etched parts 17 and 25 would have been fitted in place during normal cruising, but would have been removed completely when assault or flying operations took place. The choice is to fit them or not depending on how the model is to be presented.

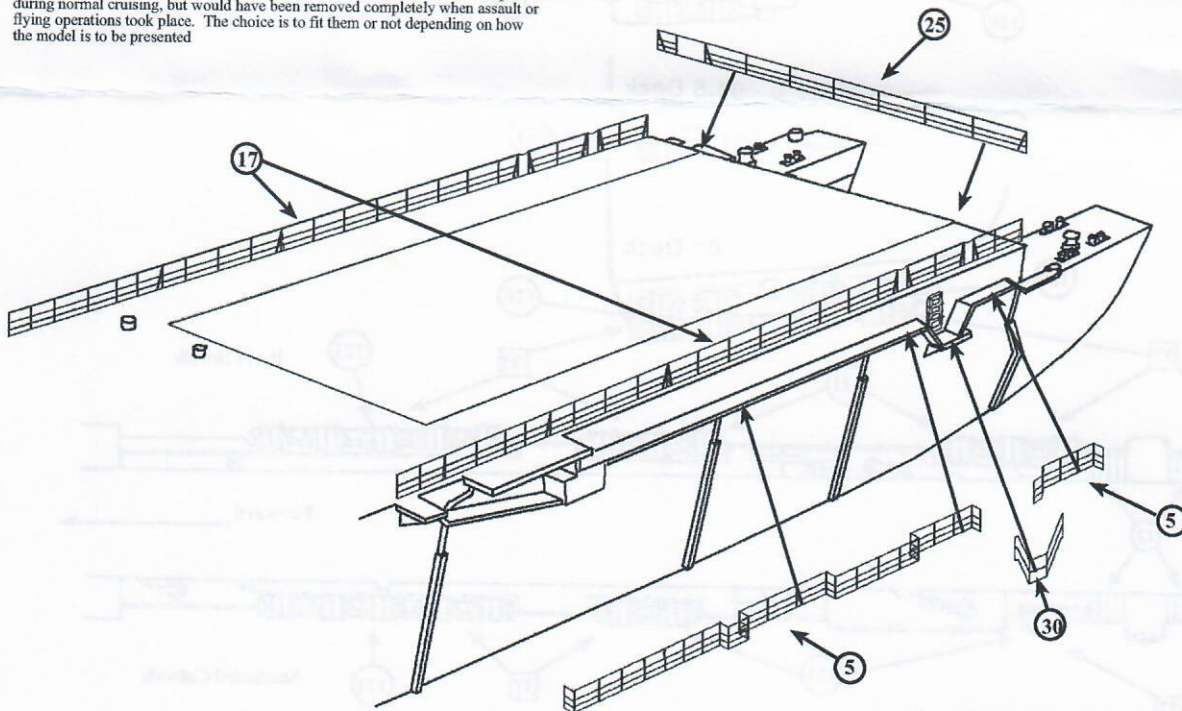

Shape and fit the sections of railing, etched parts 5, to the three edges of the port flight deck catwalk. The shape includes recesses for the positioning of lengths of life raft canister racks that will be shown in a further diagram.

Quarterdeck and Stern Gate Fittings

Fold down the sides of the Crane Rest, etched part 54, so that they are parallel, then fold down the small angled corner braces and fix into place. Fit the assembly into place as show right.

Shape the railing section, etched part 20, to the edges of the port side quarter deck/ dock extension as shown. Fit the crane base, resin part 14 to the raised circular locating point in the desired position.

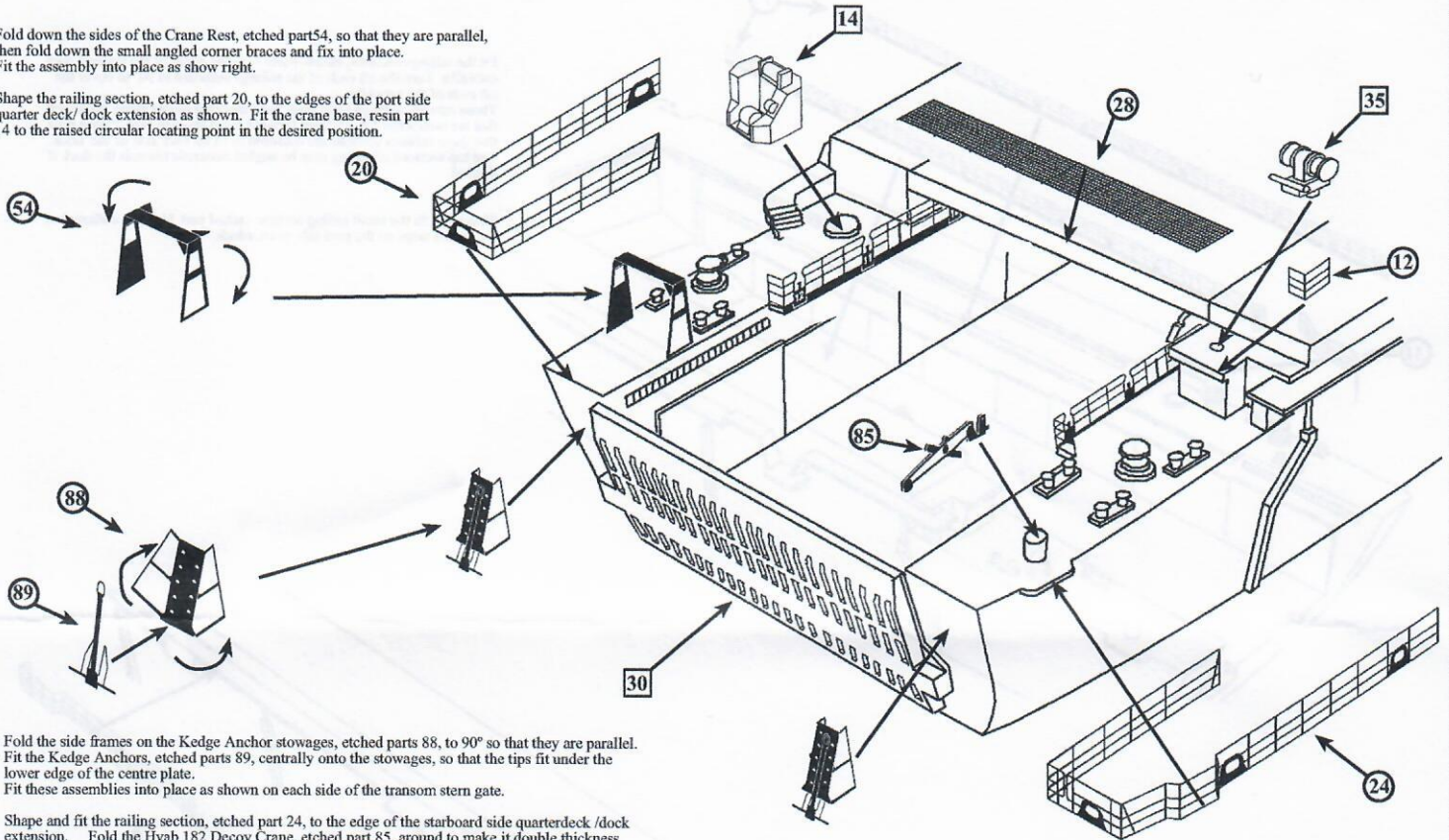

Fold the side frames on the Kedge Anchor stowages, etched parts 88, to 90° so that they are parallel. Fit the Kedge Anchors, etched parts 89, centrally onto the stowages, so that the tips fit under the lower edge of the centre plate. Fit these assemblies into place as shown on each side of the transom stern gate.

Shape and fit the railing section, etched part 24, to the edge of the starboard side quarterdeck /dock extension. Fold the Hyab 182 Decoy Crane, etched part 85, around to make it double thickness with the relief etched detail outermost. Fit the assembly to the top of the post mould to the deck.

Fit the 182 Decoy Winch, metal part 35, to the locating hole on the half height platform aft of the flight deck. Fit the inclined ladders, etched parts 36, so that the longer section of ladder fits into the recess between the platform and the outer catwalk. The short section of ladder fits from the platform up to the flight deck adjacent to the gap in the railings if fitted.

Life Raft Canister Distribution

Follow the diagram on the right to locate the correct positions of the various life raft racks on the forward life raft platforms on each side of the superstructure.

Single liferaft racks have a hooked outer section to allow the rack to overhang the edges slightly. This applies to all the single life raft racks.

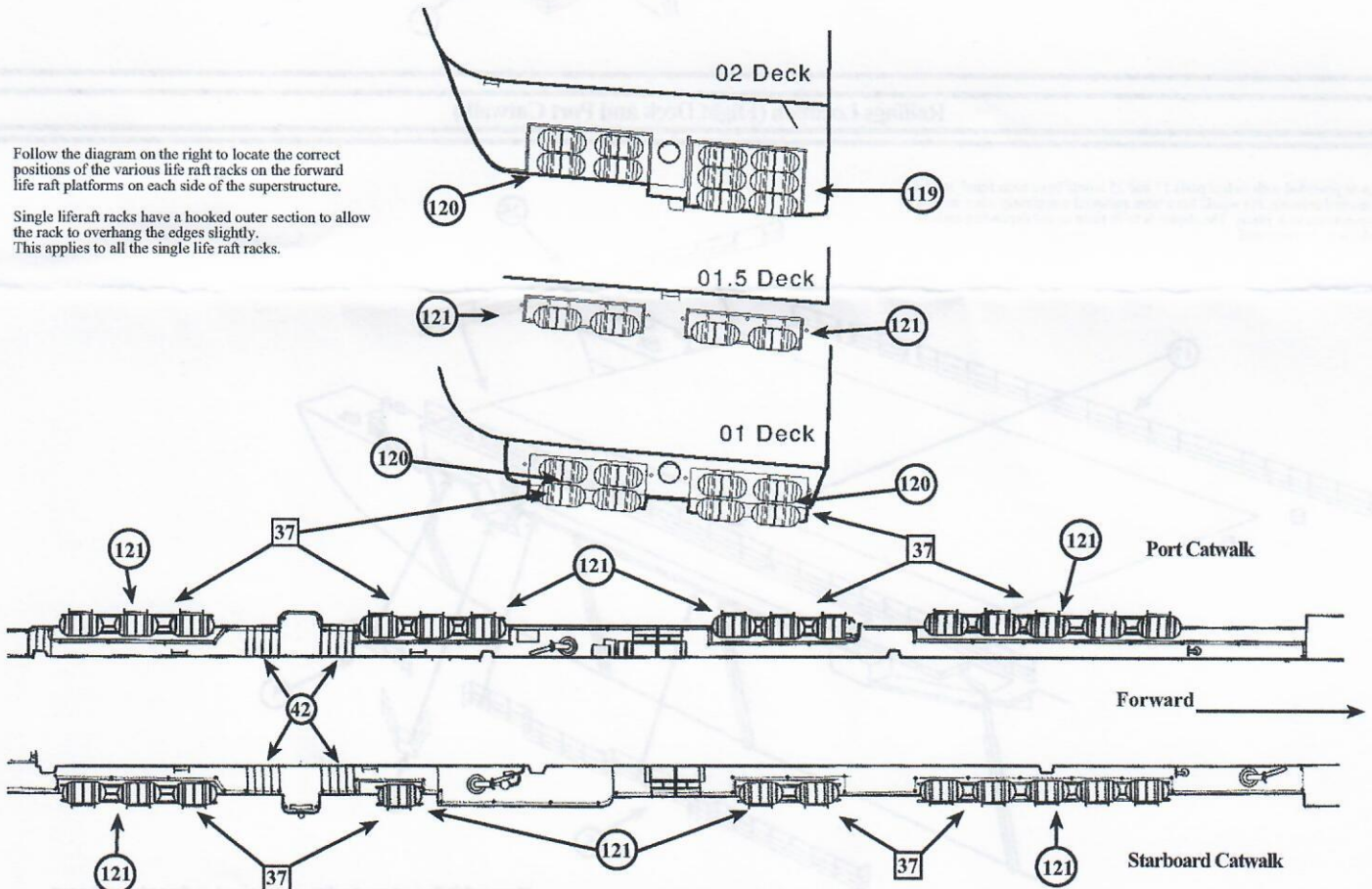

Inclined ladders, etched parts 42, may be shaped and used to replace the solid sections of angled moulding at the catwalk access points port and starboard if desired.

Landing Craft (LCU) Details

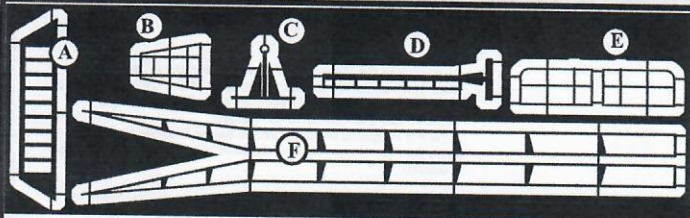

98

A small fret of parts has been provided to finish off the Landing Craft LCU's with some fine details. If any vehicles or tanks are needed to make up a diorama, it is recommended that Starling Models website is visited <https://starling-models.co.uk> where a range of armoured and soft skin vehicles can be found in 1/350 scale.

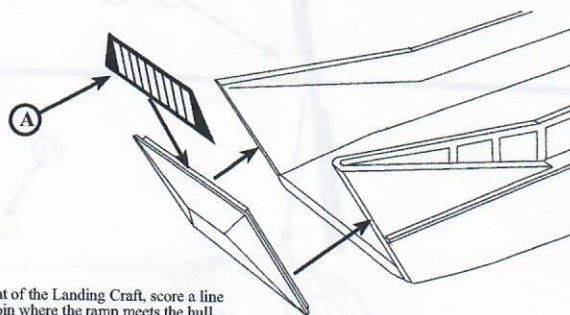

To close the ramp at the front of the Landing Craft, score a line along the under side at the join where the ramp meets the hull. When the line is deep enough the ramp will snap off cleanly and can then be fixed in the closed position.

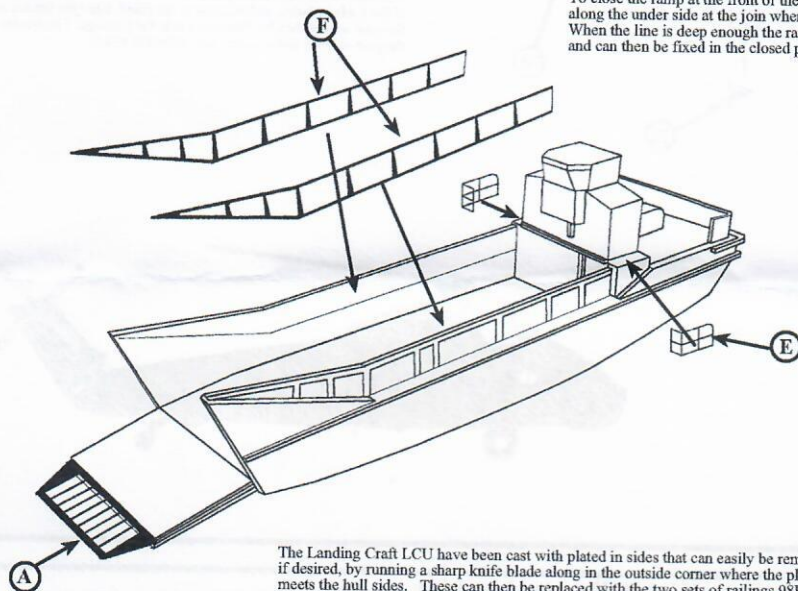

The Landing Craft LCU have been cast with plated in sides that can easily be removed if desired, by running a sharp knife blade along in the outside corner where the plating meets the hull sides. These can then be replaced with the two sets of railings 98F.

Shape and fit the two small sections of railing, etched parts 98E, to the edges of the bridge wing decks. Fold the sides of the Kedge Anchor stowage, etched part 98B, to 90° so that they are parallel, then fit centrally into place on the stem. Fit the Kedge Anchor, 98C, to the frame as shown right.

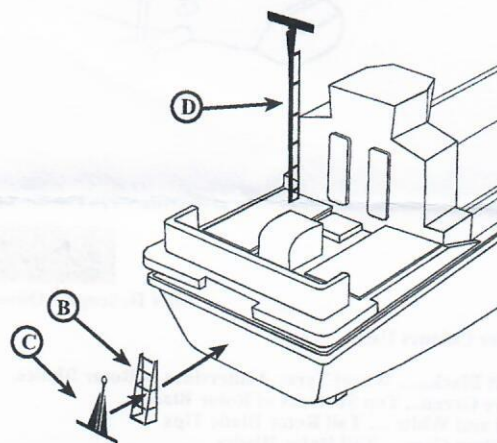

General Instructions

1. Etched parts 40, the HF/DF Antenna assembly has been included for fitting to the Fore Mast top pole if required as part of the fit being portrayed. It is assembled by locating the vertical bars on the half sections against the vertical central bar on the full section. The half sections should fit on each side at 90° to the central post.
2. A selection of ventilator grills of various shapes and sizes has been included in this set for fitting as desired. The locations of most of these are noted in the parts list on pages 2 and 3, but etched parts 108 and 110 are for general use on the port and starboard sides of the superstructure on 1 deck. These are all fitted in the same way, using the raised rectangular mouldings on the resin parts to correctly identify their location and provide a base onto which they are fitted.
3. Etched parts 113, Binocular sights are folded in half so that the relief detail is outer most. The binoculars at the top are folded outwards to give better 3D appearance. These are located at the front of 03 deck forward, below the bridge.
4. The Flight Deck Floodlights, etched parts 117, are supplied in strips of two, three and four lamp backs. To give a better 3D appearance, cut some small strips of plastic rod and attach to the lamp backs as the light shields would appear.
5. The small brackets, etched parts 116, form a tripod when shaped and are sometimes fitted with the feet to the fronts of the bridge wing bulwarks, single leg to the top. These are spaced equally, with two on each side.
6. Etched parts 47, have been supplied to fit on the outer sides of each funnel to mount the ships combined operations funnel badge. This badge comes in the form of a decal and is applied in the same way as the ships numbers and other markings.
7. The model has been cast with the side accommodation ladders moulded into the stowed position. However, if it is desired to build a diorama with these ladders deployed down to boats in the water, then etched parts have been provided to make these possible. First the resin mouldings must be cut away to the upper landing. Etched parts 62 are to represent the short top sections of ladder that are fixed in place leading down from the upper landing. These are shaped by folding the edges to 90° so that they are parallel, then turning each step out to the horizontal. The remaining ladder sections 60 and 61 are also shaped in this way. Etched parts 60 are the upper sections of the accommodation ladder and it is this section that is hinged on to the short ladder section 62. This is lowered down to the half way point, where after, ladder section 61 slides out from inside until the ladder is fully extended. The handrails on ladder section 61 will have to be fixed into place on the sides of ladders 60 to give extra strength.
8. Etched part 90 is the wire antenna spreader for the mast WT antennas. This fits into place centrally on 03 deck aft, just in front of the auxiliary conning position.

Westland Wessex HU5 Helicopter Assembly

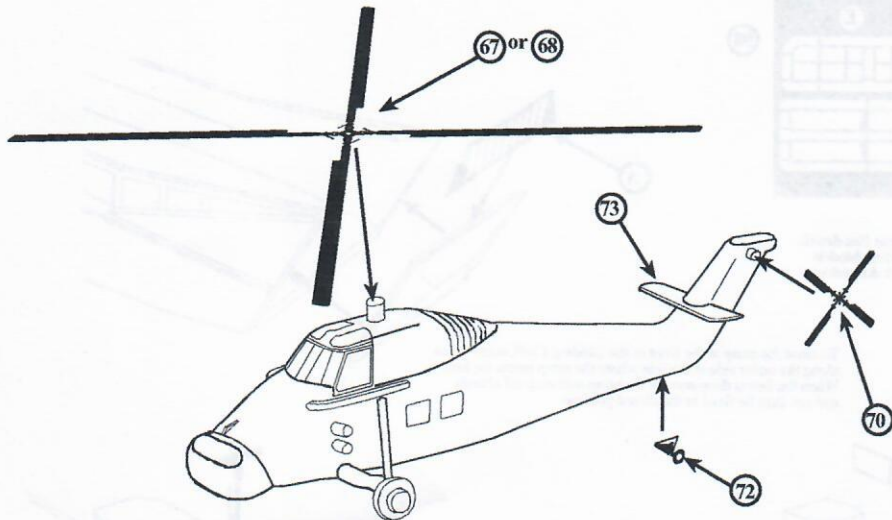

To assemble the Wessex helicopter, first clean off any casting flash that may be around the extremities, especially the pouring lug that has been situated where the tail wheel should go. Remove this and smooth in the surface.
A choice of spread or folded rotors has been given so that the modeller may choose to have the helicopter stowed in the hangar if desired.

Fit the tail rotor, etched part 2, in to place on the tail pylon as shown. To fold the tail a cut will have to be made down the fuselage just aft of the tail wheel and the tail folded along the port side of the fuselage.

Fit the tail wheel etched part 3, in to place. Etched part 5 has been supplied as a replacement in case of any casting damage to the horizontal stabiliser, and is not essential to fit otherwise.

Fit the main rotor blades, etched part 1, to the spindle on the top of the fuselage, so the rotation would be in an anti clockwise direction when viewed from above.
If the folded blades, etched parts 6, are fitted, bend the blades at the root so that they lay flat along side the fuselage. The blades on the port side lay outboard of the folded tail pylon

Hannants XTra Colour X028 BS 298



RN Helicopter Olive Drab

Other Colours Used

- Matt Black..... Wheel Tyres, Undersides of Rotor Blades.
- Olive Green... Top Surfaces of Rotor Blades
- Red and White Tail Rotor Blade Tips
- Medium Grey.... Tail Rotor Blades



Westland Sea King HC4 Helicopter Assembly

The kit parts depict the Seaking fitted with the Sandbox filter in front of the engine intakes. This is correct for the later fits, but the old style FOD shield have been supplied in case anyone wishes to model the Sea King as an earlier HC4

The top cover for the rotor head can be cut from a disc of plastic card. This also applies to the set of spread rotor blades provided as etched parts 77, that can be fitted instead of the folded ones.

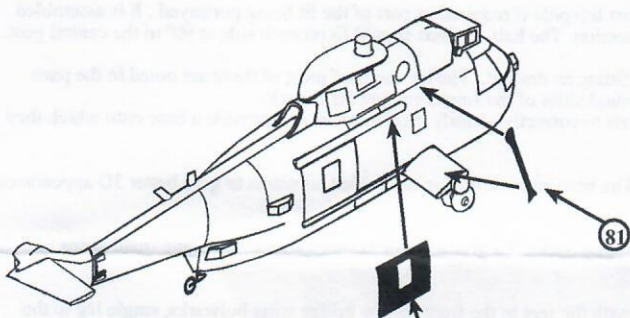

The large cargo door can be modeled in the open position, by carefully cutting the molded door out from the kit parts and replacing it with etched part 5.

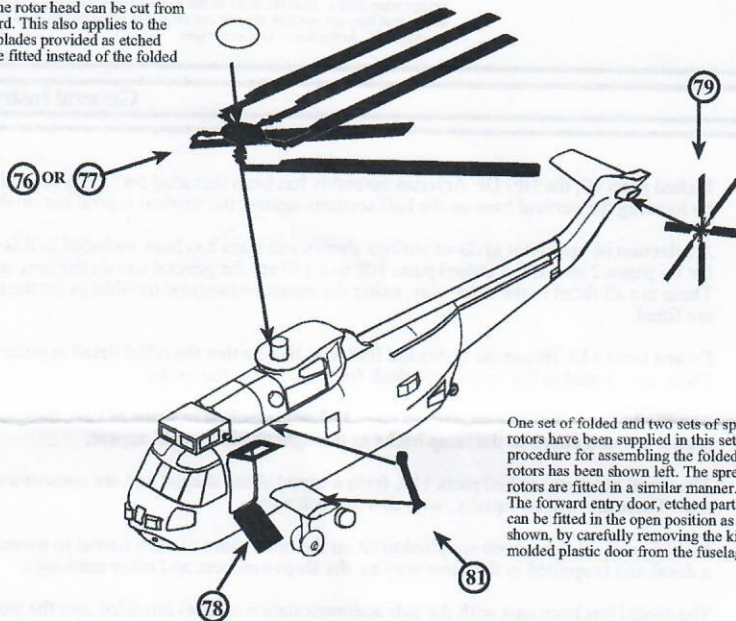

One set of folded and two sets of spread rotors have been supplied in this set. The procedure for assembling the folded rotors has been shown left. The spread rotors are fitted in a similar manner. The forward entry door, etched part 4, can be fitted in the open position as shown, by carefully removing the kit's molded plastic door from the fuselage.



Humbrol 116
RN Dark Green

Other Colours Used

- Matt Black..... Wheel Tyres, Undersides of Rotor Blades.
- Olive Green..... Top Surfaces of the Rotor Blades
- Red and White Tail Rotor Blade Tips
- Gloss Black.... Tail Rotor Blades



Main Colour Chart and Painting Guide

R.N. Light
Weatherwork
Grey
Humbrol 127

R.N. Light
Deck Grey
Humbrol 106

Dirty Wood Planking
Dark Earth
Humbrol 29

Anti Fouling Red
Humbrol 100

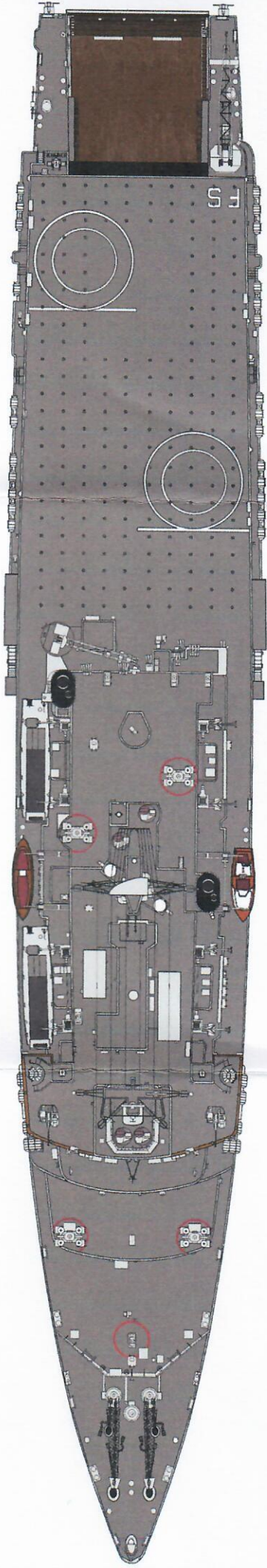
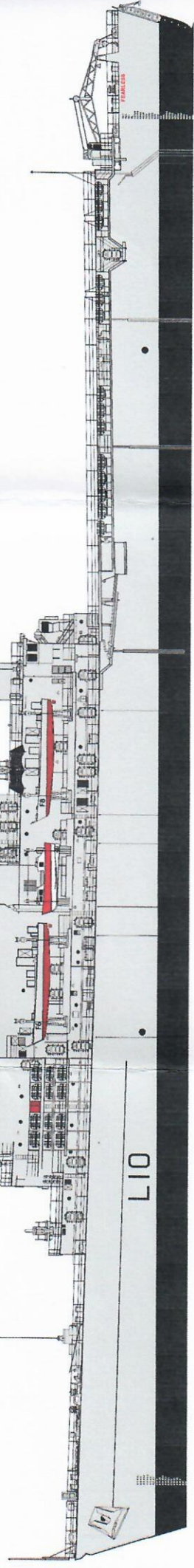

- The colour guide above shows the main scheme and the areas covered. There are smaller less obvious areas that are listed below.
- Matt Black. Upper parts of Exhaust Stacks. Gun Barrels. Waterline Boot Topping, Funnel Tops
 - Natural Wood. Insides of Whaler, Cheverton Decking, Wood Rubbing Strips Inside the Dock Walls
 - Matt White. SCOT Radomes, Whaler Below Waterline, Cheverton Motor Boat Coachwork and Lower Hull. Life Raft Canisters
 - Red. Sides of Whaler and Cheverton
 - Bronze. Propellers.

Pennant Numbers Flight Deck Code Letters for Ships of the Class
L10 HMS Fearless / FS L11 HMS Intrepid/ ID