



**INTERESTING FACTS ABOUT YOUR SURFACE-TO-AIR GUIDED MISSILE**

**NIKE**

Standing in readiness throughout the United States on the outskirts of our cities are Nike guided missile bases which guard our nation's vital centers from enemy aircraft.

**NIKE** (pronounced ni-key) is a major factor in the defense network system of our country. Radar bases located throughout the entire country will first detect the approach of enemy aircraft and transmit this information to various Nike bases. Within minutes they are ready for action. At the base, acquisition radar detects and keeps a running account of the approaching aircraft until the target crosses Nike's distant and invisible deadline at which time missile is fired. Simultaneously target radar locks on target and feeds data into missile control unit, which interprets combined data and activated controlling devices in missile until target is intercepted and destroyed.

**NIKE** is composed of two parts, namely booster and guided missile. The booster provides the power for initial take off and at a predetermined height falls away to earth. The guided missile which contains the war-head and guidance devices is then controlled by the ground radar.

**NIKE** is effective to a height of 60,000 feet and a range of 30 to 50 miles. At a speed of 1500 miles per hour it can out-manuever bombers and the fastest fighters.

Working as a team **NIKE** and **\*SKYSWEEPER** (radar-controlled Anti-Aircraft Gun) seek out and destroy enemy aircraft that have penetrated outer defenses.

*Frog SKYSWEEPER KIT ALSO AVAILABLE IN SERIES "M" SCALE*

INTERNATIONAL MODEL AIRCRAFT LTD. LONDON S.W.19



SERIES

**M**

SCALE

$\frac{3}{8}$  in. = 1 ft.

# NIKE assembly instructions

# FROG DE-LUXE MODELS

READ INSTRUCTIONS CAREFULLY BEFORE BEGINNING ASSEMBLY!

## YOUR FROG DE-LUXE MODEL

Every effort has been made to provide you, the hobbyist, with a model kit unparalled for strict adherence to actual official parts. Authentic details were generously furnished by the U.S. Army Ordnance Corps and the Office of the Chief of Information and Education. Without their cooperation, the development of your model embodying all the phases of authentic realism, would not have been possible.

Your model is one of our series "M" which are scaled to inch 1 foot, thus making possible a collection wherein all models are in true scale to each other.

The opening features will enable you to demonstrate the various steps Nike actually goes through. Nike Missile can be manually transported along slide rails onto elevating rail. At this point it is in a ready position. Missile can then be elevated and remain in any position up to 85° firing angle made possible by authentic operating piston design. Missile and booster assembly may be separated from Missile rail and in turn separated from Missile as in actual flight. Alerts and steering fins on Missile are free to rotate as required for operational control of post-Nike.

### GENERAL INSTRUCTIONS

A. Examine pieces and remove excess plastic with a sharp knife making sure all protrusions have been removed. Notice that most pieces have a small tab with part number for ease of identification. Remove when piece is properly identified.

Follow numbered steps carefully for ease of assembly

B. Purchase Frog cement for styrene plastic at your local store. Have a small cloth handy to wipe any cement you may accidentally get on your fingers.

C. See back of details for instructions on how to apply.

**PAINTING YOUR MODEL**—Essentially, your model has been molded in the authentic colors of olive drab for the launcher and white for the missile and booster assembly. However, it is recommended that certain small parts be painted to supply additional realism, if you wish to display your model. If you are going to paint your model, paint these parts before assembling pieces. Use only enamel paints and allow sufficient drying time. Color recommendations appear on instructions.



Keep paint from remaining areas. Recommended tools for painting are a small (#1) artists brush, and the end of a toothpick or opened paper clip for minute detailing, such as eyes, rivet heads, etc.

### "NO-SHOW" CEMENT TECHNIQUE

"NO-SHOW" CEMENTING is designed into your kit. The parts have been specifically engineered to enable you to complete a model which is free of burrs and smears. The instructions and drawings have also been designed to carry out the "NO-SHOW" cementing feature, through the use of blue lines to indicate cementing areas. These design features will enable you to obtain favorable results and reward you with a model you will be proud to display.

1. First, locate and fit pieces together, prior to cementing.
2. Then, APPLY CEMENT SPARINGLY ONLY TO THE AREAS INDICATED IN BLUE ON THE INSTRUCTION DRAWINGS. Hold or clamp parts until a permanent bond is assured.

NOTE: Circled numbers are ONLY for parts identification, and have no bearing on assembly sequence.

## 1 piston, elevating rail, power unit, cylinder

### CHECK FIT OF PIECES & PAINT NECESSARY PARTS BEFORE ASSEMBLY

Fit Cylinder Cap (20) over Piston Rod (31) as shown. Slip Piston Ring (29) over end of Piston Rod seating it at shoulder. Place cement into Piston (28) and press over end of Piston Rod locking Piston Ring in place. Set aside to dry thoroughly.

Cement Front Cylinder Hinge (22) to other Cylinder Cap (20). Fit hole in Front Cylinder Hinge over pin in left half of Hydraulic Power Plant (21) and cement to right half of Hydraulic Power Plant (21) being careful not to get cement on Cylinder Hinge. Cement Stanchion Cap (26) Mounting Disc (27) and Footing (28) to studs on Power Plant as shown. Set aside to dry.

Fit hole in Piston Rod over pin on right half of Elevating Rail (32) and cement to left half of Elevating Rail (32) being careful not to get cement on pin. Apply cement to Elevating Slide Rails (44) and insert Slide Rails into slots in Elevating Rail. Apply cement to pin on Elevating Rail, and cement Pivot Pin Guard (34) to pin on Elevating Rail.

Now fit two halves of Cylinder (24-27) together, making certain raised rings on Cylinder match as shown. Apply cement sparingly to inside of Cylinder Cap on Power Plant and press combined Cylinder halves into cap. Now insert Piston Rod assembly into Cylinder. Apply cement very carefully to Cylinder ends (as shown in blue) and press Cylinder Cap previously fitted over Piston Rod over Cylinder.

SCALE  
M 1/4 in. = 1 ft.

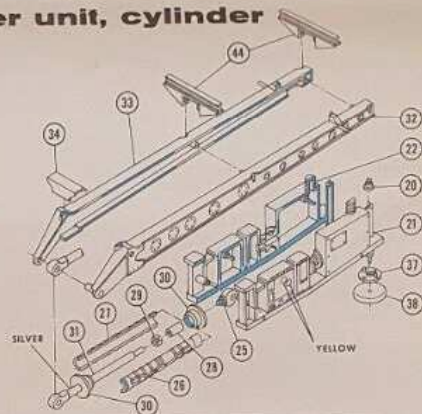

## 2 launcher frame

### CHECK FIT OF PIECES & PAINT NECESSARY PARTS BEFORE ASSEMBLY

Place left Launcher Frame (24) on flat surface. Apply cement to large area only (as shown in blue). Cement Power Plant assembly and position Cylinder and fit pivot hole in Elevating Rail over pivot pin on Launcher Frame.

Apply cement to all pins, holes and other contact points on left half Launcher Frame (24) including large blue area shown on Power Plant. Then join to right half of Launcher Frame (23). Bind with rubber bands until dry.

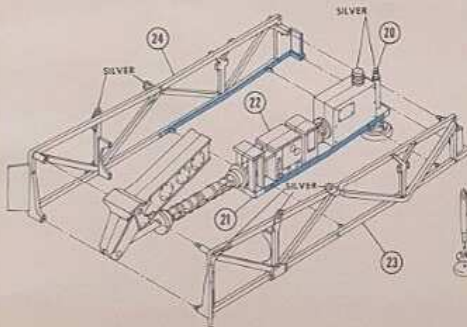

## 3 launcher supports, slide rails

### CHECK FIT OF PIECES & PAINT NECESSARY PARTS BEFORE ASSEMBLY

Cement Mounting Disc (27) and Footing (28) to pins on left and right Launcher Supports (39, 40). Now cement supports to Launcher Frame by applying cement to tabs as shown.

Cement Launcher Base (43) to locating pin on left front Slide Rail (41). Cement Launcher Hilt (44) over Launcher Base. Cement left and right front Slide Rails (41, 41) as shown. Cement rear Slide Rail (40).

Cement Mounting Disc (27) and Footing (28) to pins on End Rails (39) as shown. Now cement End Rails to Slide Rails. NOTE: Additional End Rails are not required between installations if you are combining two or more Nike installations in series.

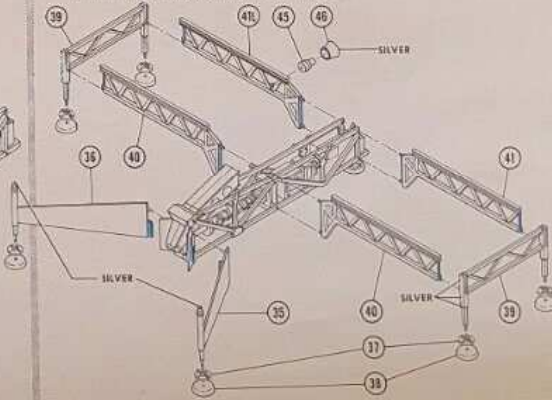

## 4 missile rail

### CHECK FIT OF PIECES & PAINT NECESSARY PARTS BEFORE ASSEMBLY

Apply cement to pins and edges of right Missile Rail half (18) and insert pin on Support Flap (47) into hole in front half as shown. Avoid getting cement on Support Flap. Cement left Missile Rail half (19) and bind with rubber bands until dry.

Now join two left Saddle Halves (42) with two right Saddle Halves (43) by applying cement as shown. Assembled Saddles can now be cemented to Missile Rail by applying cement to areas shown and pressing Saddles into Missile Rail slots.

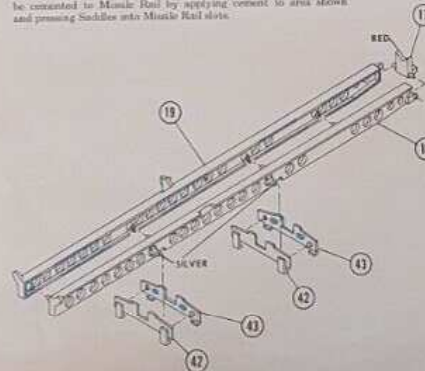

## 5 missile booster body

### CHECK FIT OF PIECES & PAINT NECESSARY PARTS BEFORE ASSEMBLY

Carefully cement left and right Booster Body Halves (3-4) together by applying cement to contact points shown. Bind with rubber bands until dry.

Apply cement to Booster Body front end and assemble Booster Cap (4) by slipping it in Cap with slot in Booster Body.

Assemble three Booster Stabilizers (2) into Booster Body slots by gently sliding Stabilizers forward and down until flush with left and right Booster Body contour. Place cement on collar of exhaust Screen (1) and insert into rear of Booster Body by pushing forward until firmly seated in the slots of the three Stabilizers. The Exhaust Screen will locate itself approximately 1/8 inch inside Booster Body. This unique design will firmly lock all of the parts in proper position.

Apply cement to pin on Booster Socket (6), and cement to Booster Cap (4) (previously assembled to Booster Body), making sure flat on pin lines up with flat in hole.

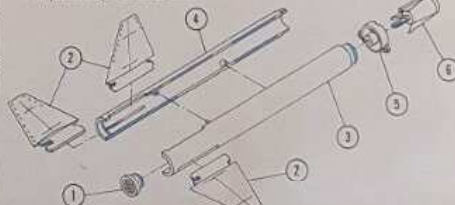

## 6 NIKE guided missile

### CHECK FIT OF PIECES & PAINT NECESSARY PARTS BEFORE ASSEMBLY

Insert Aileron Socket (10) into hole between rear circular grooves in right half of Missile Fuselage (12) making sure that tab on socket faces nose end of Missile Fuselage as shown. Now place Dual Aileron (7) across rear circular grooves. Repeat above procedure by inserting Steering Fin Socket (11) into hole between front circular grooves (making certain that tab on socket faces nose end of Missile Fuselage). Then position Dual Steering Fin (14) across front circular grooves in same manner as Dual Aileron assembly.

Missile Fuselage left half (13) may now be cemented to right half by carefully applying cement to contact points shown, taking care to avoid getting cement on Aileron and Steering Fin pivot points. Join fuselage halves, making sure Steering Fin Socket and Aileron Socket project thru holes in Fuselage halves. Bind with rubber bands.

NOTE: Providing previous instructions were carefully followed, Ailerons and Steering Fins will be free to rotate similar to actual missile.

Cement Missile Nose (47) to Fuselage by applying cement to Fuselage as shown.

Place small amount of cement on pins of two Steering Fins (15) and insert into Steering Fin Socket holes. Repeat procedure for Ailerons (8) into Aileron Socket, making sure they are positioned as shown.

Apply cement to pins and tabs of four Roll Stabilizers (9) individually, and insert into holes at rear Missile Fuselage.

Apply cement to tabs of four Antenna (16), and insert into Missile Fuselage, making sure they are positioned as shown.

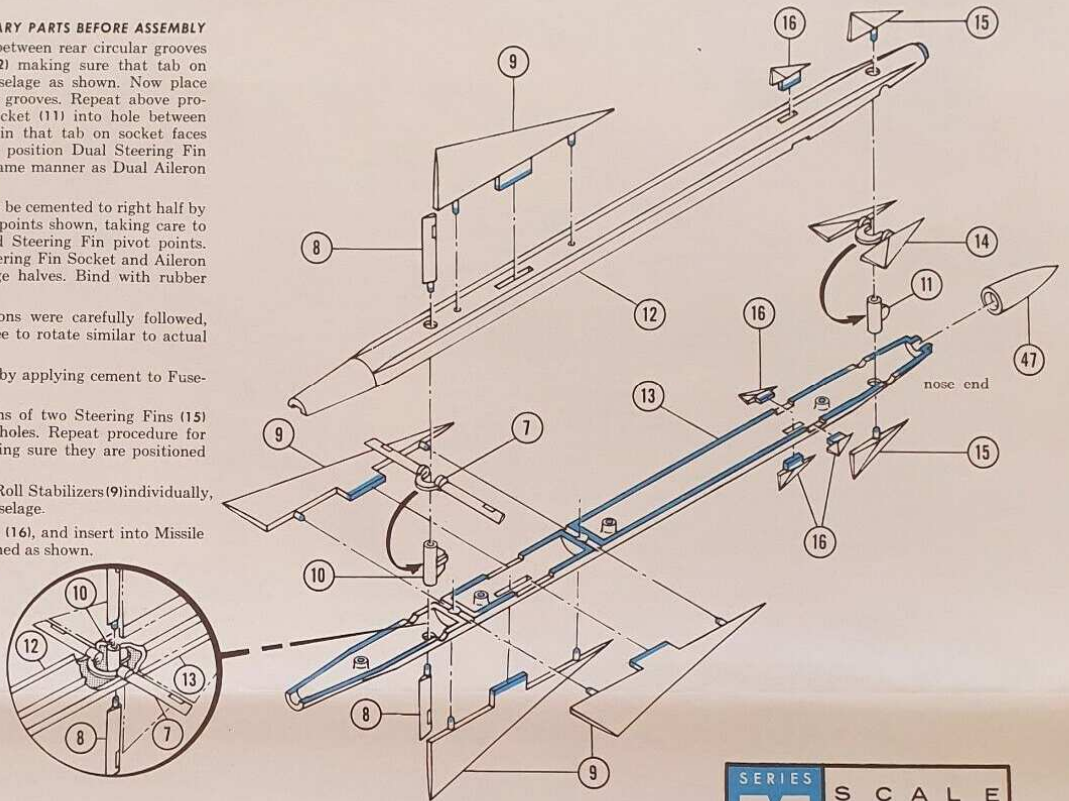

## 7 decals (ON BOOSTER BODY AND MISSILE)

At this point Decals can be applied to Missile Fuselage and Booster assemblies as shown.

Booster and Missile may be joined without cement by turning Missile in Booster Socket until flat on pin in socket matches flat in hole on Missile and gently pressing Missile and Booster together.

Nike Missile and Booster assembly can now be mounted on Missile Rail by fitting projecting pins on Rail to matching holes in Missile Booster Cap as shown.

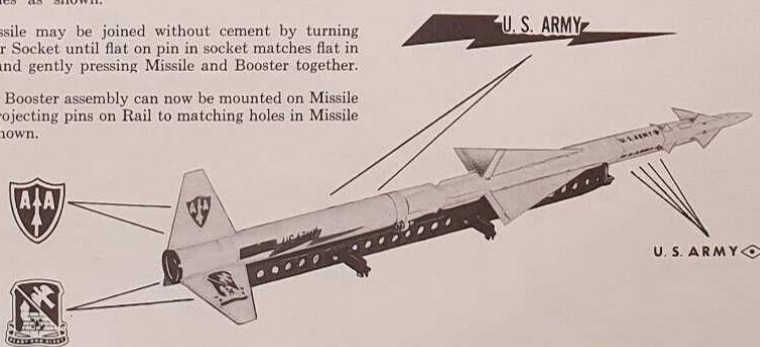

SERIES  
**M** SCALE  
3/8 in. = 1 ft.

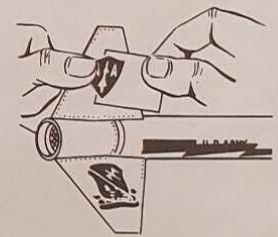

**TO APPLY DECALS** - First see instructions on back of decals. Then cut decals apart INSIDE the dotted lines. See illustration for correct location, then apply one subject at a time. Slide decal partly off paper backing, hold decal in correct position on model, then slip backing from beneath decal. Adjust position if necessary, smooth out any wrinkles and blot with a soft cloth.

**Your NIKE guided missile installation  
is complete and ready for operation!**



# GUARDIAN OF AMERICA'S FIRST LINE OF DEFENSE

M550  
SURFACE-TO-AIR  
GUIDED MISSILE  
NIKE

8/9 each

The famous Nike now reproduced in dramatic, museum-quality detail. 81 parts, molded in authentic white and olive drab colors. In exact scale, this model is 14½" long and 8½" wide. Projectile, missile rail, elevating rail, elevating mechanism completely operative when model is assembled. This kit is designed so that additional kits can be joined to form realistic battery of launchers. Kit complete with 3 lifelike crew members—Commander, sentry, technician. Authentic decals.



INTERNATIONAL MODEL AIRCRAFT LTD.  
MORDEN ROAD, LONDON, S.W.19

**THE MISSILE AND RAIL** are now ready to be placed on launcher by slipping the missile rail saddles over slide rails and sliding assembly along rails until it is flush with the elevating slide rail mounts. Lowered, the missile is in a ready position. Raised to maximum elevated position of 85°, the missile is ready to fire and track down relentlessly any flying object.

**SOLDIERS** may be positioned as shown or as desired. Also entire assembly may be mounted on a wooden board if you so desire.

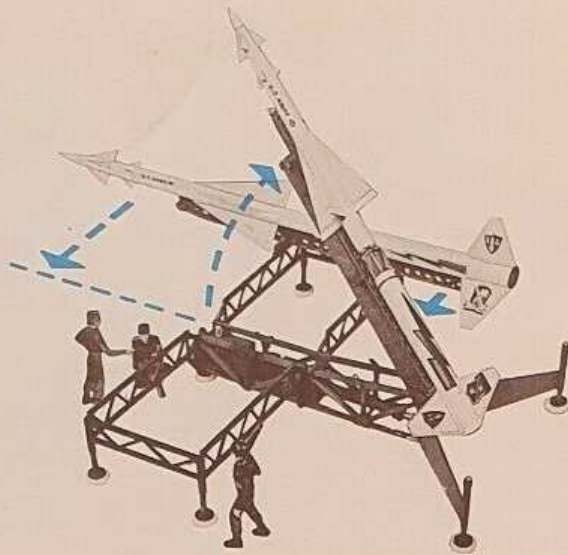

## OTHER FROG SERIES "M" KITS

*Guardian of the sky*

### M552 SKYSWEEPER 75 MM RADAR ANTI- AIRCRAFT GUN

A foremost protector from hostile aircraft. Kit includes 34 individual operating assemblies, precision engineered to exacting specifications. 134 parts.



*Supremacy in the field*

### M551 SELF PROPELLED 8 INCH HOWITZER

A new Atomic mobile fortress for ground encounter. Richly detailed and unsurpassed for genuine operational features. 138 parts.



### BUILD A BATTERY OF NIKES!

Kit has been designed to enable you to mount NIKES in series as is shown in the actual photo of a U. S. Army NIKIE battery.

*Giant of them all!*



### M553 ATOMIC CANNON

280 MM GUN - Man's creation of a super mobile artillery weapon consisting of over 300 super-detailed pieces. The completed model incorporates the ultimate in combat operational features. Overall length 32".

## PARTS LIST FOR YOUR SERIES M NIKIE

- |                           |                                |                            |                                  |
|---------------------------|--------------------------------|----------------------------|----------------------------------|
| 1. EXHAUST SCREEN         | 14. DUAL STEERING FIN          | 27. CYLINDER—L.H.          | 40. REAR SLIDE RAIL (2)          |
| 2. BOOSTER STABILIZER (3) | 15. STEERING FIN (2)           | 28. PISTON                 | 41. RIGHT FRONT SLIDE RAIL       |
| 3. BOOSTER BODY—R.H.      | 16. ANTENNA FIN (4)            | 29. PISTON RING            | 41L. LEFT FRONT SLIDE RAIL       |
| 4. BOOSTER BODY—L.H.      | 17. MISSILE SUPPORT FLAP       | 30. CYLINDER CAP (2)       | 42. MISSILE RAIL SADDLE—L.H. (2) |
| 5. BOOSTER CAP            | 18. MISSILE RAIL—R.H.          | 31. PISTON ROD             | 43. MISSILE RAIL SADDLE—R.H. (2) |
| 6. BOOSTER SOCKET         | 19. MISSILE RAIL—L.H.          | 32. ELEVATING RAIL—R.H.    | 44. ELEVATING SLIDE RAIL (2)     |
| 7. DUAL AILERON           | 20. STANCHION CAP              | 33. ELEVATING RAIL—L.H.    | 45. LOUDSPEAKER BASE             |
| 8. AILERON (2)            | 21. HYDRAULIC POWER PLANT—R.H. | 34. PIVOT PIN GUARD        | 46. LOUDSPEAKER HORN             |
| 9. ROLL STABILIZER (4)    | 22. HYDRAULIC POWER PLANT—L.H. | 35. RIGHT LAUNCHER SUPPORT | 47. MISSILE NOSE                 |
| 10. AILERON SOCKET        | 23. LAUNCHER FRAME—R.H.        | 36. LEFT LAUNCHER SUPPORT  | 48. BATTERY COMMANDER            |
| 11. STEERING FIN SOCKET   | 24. LAUNCHER FRAME—L.H.        | 37. MOUNTING DISC (7)      | 49. SENTRY                       |
| 12. MISSILE FUSELAGE—R.H. | 25. FRONT CYLINDER HINGE       | 38. FOOTING (7)            | 50. TECHNICIAN                   |
| 13. MISSILE FUSELAGE—L.H. | 26. CYLINDER—R.H.              | 39. END RAIL (2)           | 51. DECALS (10)                  |