



## Eurocopter EC 145 REGA

Die EC 145 ist ein leichter zweimotoriger Hubschrauber der in Zusammenarbeit von Eurocopter und der japanischen Firma Kawasaki Heavy Industries unter der Bezeichnung BK 117C-2 entwickelt wurde. Dabei war die BK 117C-1 - die von diesen Firmen bereits in Kooperation gebaut wurde - das Ausgangsmuster für einen neuen Hubschrauber der besonders die Ansprüche der französischen Sécurité Civile (Zivilschutz und SAR) erfüllen sollte die nach einem Nachfolger für die bisher verwendeten Typen suchte. (siehe Revell Bausatz 04481) Aus dem internationalen Wettbewerb ging im Dezember 1997 die als EC 145 bezeichnete Maschine als Sieger hervor und am 23. July 1998 wurden die ersten 32 Maschinen von der Sécurité Civile bestellt. (Sie können aus einem anderen Revell-Bausatz gebaut werden.) Gegenüber der BK 117C-1 hat die EC 145 einen neuen Rumpf mit einer geräumigeren Kabine. Teile der Elektronik, der Heizung und der Avionik zur Flugsteuerung und Navigation basieren ebenso auf Bauteilen und Erfahrungen mit der EC 135, wie auch das neue Hauptrotorsystem das mit den optimierten Profilen der Rotorblätter mehr Auftrieb bringt und zugleich wesentlich weniger Fluglärm erzeugt. Ein weiterer Vorteil der neuen Rotorblätter an der EC 145 sind wesentlich geringere Vibrationen und eine um 25% größere Reichweite. Die EC 145 ist für Blindflug zugelassen und kann wahlweise mit einem oder mit zwei Piloten betrieben werden. Beim Internationalen Luftfahrtsalon in Le Bourget im Juni 2001 wurde die EC 145 zum ersten Mal der Öffentlichkeit vorgestellt und bei dieser Gelegenheit bestellte auch der schweizerische Luftrettungsdienst REGA seine ersten EC 145. Die Rega wurde am 27. April 1952 von dem Arzt Dr. Rudolf Bucher innerhalb der SLRG - Schweizerische Lebensrettungsgesellschaft gegründet - zu einem Zeitpunkt als Luftrettung für die meisten noch ein utopische Unterfangen war. Seit her hat man bei Rega für eine ganze Reihe weiterer Meilensteine gesorgt. 1957 stellte man den ersten Hubschrauber - eine Bell 47J in Dienst, die im Wallis von dem berühmtesten Rettungspiloten Hermann Geiger geflogen wurde. Im Juni 1973 kaufte sie als weltweit erster ziviler Rettungsdienst eine Learjet 24D „Henri Dunant“ als Ambulanz-Jet - nachdem man bereits 1960 mit einer gemieteten Piaggio P 166 die ersten Rückführflüge verunfallter Schweizer begonnen hatte. Im November 1973 nahm man mit der Bo 105C den ersten Ambulanzhubschrauber mit zwei Triebwerken in Dienst der auf dem Dach des Zürcher Kinderspitals stationiert wurde und bald wegen seines ständigen Einsatzes als Transporter für Risiko-Neugeborene in Isolbetten („Brutkästen“) den Spitznamen „Babyheli“ erhielt. Am 12. Dezember 2002 erhielt die Rega bei Eurocopter in Donauwörth die ersten ihrer fünf EC 145. Markierungen für alle diese fünf Maschinen liegen dem REVELL - Bausatz bei. Die EC 145 der Rega sind in Basel (seit 12. 3. 2003), Lausanne (seit 4.4.2003), Bern (30.6. 2003) und Zürich-Dübendorf (seit 23. Oktober 2003) im Einsatz. Dabei spielt die EC 145 der Rega-Basis Zürich-Dübendorf eine besondere Rolle da sie sehr oft für Patiententransporte nach und von Deutschland eingesetzt wird. Die fünfte EC 145 dient als Reservemaschine, kann aber auch jederzeit zusätzlich eingesetzt werden.

### EC 145 Technische Daten:

Rumpflänge	10.19 m
Länge über alles	13.03 m
Breite über alles	3.12 m
Rumpfbreite	1.85 m
Höhe über alles	3.96 m
Hauptrotor Durchmesser	11.0 m
Heckrotor Durchmesser	1.96 m
Kabinenlänge	3.45 m
Kabinenhöhe	1.27 m
Triebwerke	2 x Turbomeca Arriel 1E2
Startleistung	2 x 771 WPS
Leergewicht	1 742 kg
Außenlast max.	1 500 kg
Rettungswinde	max. 270 kg, Seillänge 90 m
Kraftstoff max.	864 Liter
Startgewicht max.	3 550 kg
Reisegeschwindigkeit	250 km/h
Höchstgeschwindigkeit	268 km/h
Dienstgipfelhöhe	5 485 m
Reichweite	670 km
Einsatzdauer	3h 30 min
Besatzung - Rega	1 Pilot und 1 Rettungssanitäter, sowie ein Arzt 1 Trage sowie ein freier Sitz

## Eurocopter EC 145 REGA

The EC 145 is a light twin-engine helicopter that was developed under the designation BK 117C-2 by Eurocopter in collaboration with the Japanese firm Kawasaki Heavy Industries. The BK 117C-1 that had already been built by the same two firms in co-operation (see Revell model kit 04481) is the predecessor of this new helicopter, which would meet the requirements of the French Sécurité Civile (Civil Protection and Search and Rescue), who were looking for a successor to the previous types used. The winner in the international tendering procedure in December 1997 was the machine designated the EC 145 and on 23rd July 1998 the first 32 machines were ordered by the Sécurité Civile. (They can be built with another Revell model kit). Compared with the BK 117C-1 the EC 145 had a new fuselage with a more spacious cabin. Parts of the electronics, the heating and the flight control and navigation avionics were based on components used and experience gained with the EC 135, as was the new main rotor system with improved rotor blade profiles that gave more lift at the same time as it generated considerably less noise. Another advantage of the new rotor blades of the EC 145 is a considerable reduction in vibrations and a 25% increase in range. The EC 145 is certified for blind flight and can be operated by one or two pilots. The EC 145 was shown to the public for the first time at the International Air Show at Le Bourget in June 2001, when REGA the Swiss air rescue service ordered its first EC 145. The REGA was founded on 27th April 1952 by Dr Rudolf Bucher within the SLRG - Swiss Life Saving Company - at a time when air rescue for the most part was still a Utopian dream. Since then the REGA has passed a whole series of other milestones. In 1957 their first helicopter - a Bell 47J went into service and was flown at Valais by the most famous rescue pilot Hermann Geiger. In June 1973, they were the first civil emergency service in the world to buy a Learjet 24D "Henri Dunant" as an ambulance - as far back as 1960 they had begun their first flights to pick up Swiss people who had had accidents in a rented Piaggio P 166. In November 1973, the first twin-engine ambulance helicopter the Bo 105C went into service and was stationed on the roof of the Zürich children's hospital. Due to its permanent availability it was soon being used as a transporter for at-risk new-born babies in incubators and gained the nickname "Babyheli". On 12th December 2002 the REGA received the first of their five EC 145s from Eurocopter in Donauwörth. The Revell model kit contains markings for all five of these machines. The REGA EC 145s have been in use at Basel (since 12.3.2003), at Lausanne (since 4.4.2003), at Bern since (30.6.2003) and at Zürich-Dübendorf (since 23.10.2003). The EC 145 at the REGA base at Zürich-Dübendorf plays a special role as it is very often used to transport patients to and from Germany. The fifth EC 145 serves as a stand-by that can also be used at any time.

### Technical data:

Fuselage length	10.19 m
Overall length	13.03 m
Overall width	3.12 m
Fuselage width	1.85 m
Overall height	3.96 m
Main rotor diameter	11.0 m
Tail rotor diameter	1.96 m
Cabin length	3.27 m
Cabin height	1.27 m
Engines	2 x Turbomeca Arriel 1E2
Take-off power	2 x 770 shp
Weight empty	1,742 kg
Max. external load	1,500 kg
Rescue winch	max 270 kg, cable length 90 m
Max. fuel capacity	864 litres
Max. take-off weight	3,550 kg
Cruising speed	250 km/h
Max. speed	268 km/h
Service ceiling	5,485 m
Range	670 km
Operating time	3 hr 30 min
Crew - REGA	1 pilot and 1 paramedic plus a doctor 1 stretcher and one free seat

Form hergestellt und in Eigentum von Revell GmbH & Co. KG/Revell Monogram Inc. Widerrechtliche Nachahmungen werden gerichtlich verfolgt.  
Ce produit est propriété de la société Revell GmbH & Co. KG/Revell Monogram Inc. Toute utilisation ou duplication frauduleuse fera l'objet de poursuites en justice.  
Modelado y en propiedad de Revell GmbH & Co. KG/Revell Monogram Inc. Imitaciones ilícitas serán perseguidas por la ley.  
Forma prodotta dalla Revell GmbH & Co. KG/Revell Monogram Inc. e di proprietà della stessa impresa, la quale procederà legalmente contro ogni imitazione abusiva.  
Malli on Revell GmbH & Co. KG/Revell Monogram Inc. valmistama ja omaisuutta. Laittoaman kopiointiin tullaan puuttamaan oikeudellisiin toimin.  
Formen er produsert og eies av Revell GmbH & Co. KG/Revell Monogram Inc. Etterligging uten tillatelse vil bli gjenstand for rettslig forfølgelse.  
Produkcja i prawa własności firmy Revell GmbH & Co. KG/Revell Monogram Inc. Nielegalne podrobienie jest zabronione pod odpowiedzialnością sądową.  
Model, Revell GmbH & Co. KG/Revell Monogram Inc. firmasının mülkiyeti altında imal edilmiştir. Kanuna aykırı taklitler mahkemeye takip edilecektir.  
A forma előállításja és a tulajdonjog birtokosa a Revell GmbH & Co. KG/Revell Monogram Inc. A jogszegítő utaztatásokat bírósági útdíjazók.) útdíjazók.) útdíjazók.)

Mould manufactured by and property of Revell GmbH & Co. KG/Revell Monogram Inc. Illegal imitations are subject to prosecution.  
Vorm vervaardigd door en eigendom van Revell GmbH & Co. KG/Revell Monogram Inc. Onrechtmatige nabootsing worden gerechtelijk vervolgd.  
Formas produzidas e de propriedade da Revell GmbH & Co. KG/Revell Monogram Inc. Cópias não autorizadas serão processadas juridicamente como determinado na lei.  
Modellen tillverkad av och tillhör Revell GmbH & Co. KG/Revell Monogram Inc. All kopiering beivras enligt lagen om upphovsrätt.  
Formen er fremstillet af Revell GmbH & Co. KG/Revell Monogram Inc. som også har ejendomsret. Lovstridige efterligninger sagsøges.  
Μοδελι κατασκευαστηκε και περιλαμβανει την ιδιοκτησια της Revell GmbH & Co. KG/Revell Monogram Inc. Οι παρανομες μιμισεις θα καταβληκονται δικαστικως.  
Твар был вытуплен фирмой Revell GmbH & Co. KG/Revell Monogram Inc. а је јелим власничким. Прои нејаконим пародобинишм се буде постлуповат соудни цестпоу.  
Forma je proizvedena i je vlasništvo Revell GmbH & Co. KG/Revell Monogram Inc. Neovlađene kopije bodo pravno kāžnjene.





# Benötigte Farben / Used Colors

Benötigte Farben  
Required colours

Peintures nécessaires  
Benodigde kleuren

Pinturas necesarias  
Tintas necessárias

Colori necessari  
Använda färger

Tarvittavat värit  
Du trenger følgende farger

Nødvendige farger  
Необходимые краски

Potrzebne kolory  
Απαιτούμενα χρώματα

Gerekli renkler  
Potřebné barvy

Szükséges színek  
Potrebne barve

## A

hellgrau, seidenmatt 371

light grey, silky-matt  
gris clair, satiné mat  
lichtgrijs, zijdemat  
gris claro, mate seda  
cinzento claro, fosco sedoso  
grigio chiaro, opaco seta  
lysegrå, sidenmatt  
vaaleanharmaa, silkinihmeä  
lysegrå, silkematt  
lysgrå, silkematt  
светло-серый, шелковисто-матовый  
jasnoszary, jedwabisto-matowy  
ανοιχτό γκρι, μεταξωτό ματ  
açık gri, ipek mat  
svētīēšēdā, hedvābnē matnā  
vilāgosszürke, selyemmatt  
svetlo siva, svila mat

## B

grau, seidenmatt 374

grey, silky-matt  
gris, satiné mat  
grijs, zijdemat  
gris, mate seda  
cinzento, fosco sedoso  
grigio, opaco seta  
grå, sidenmatt  
harmaa, silkinihmeä  
grå, silkematt  
grå, silkematt  
серый, шелковисто-матовый  
szary, jedwabisto-matowy  
γκρι, μεταξωτό ματ  
gri, ipek mat  
šēdā, hedvābnē matnā  
szürke, selyemmatt  
siva, svila mat

## C

gelb, matt 15

yellow, matt  
jaune, mat  
geel, mat  
amarillo, mate  
amarelo, fosco  
giallo, opaco  
gul, matt  
keltainen, himmeä  
gul, mat  
gul, matt  
желтый, матовый  
žółty, matowy  
κίτρινο, ματ  
sari, mat  
žlutá, matnā  
sárga, matt  
rumena, mat

## D

schwarz, seidenmatt 302

black, silky-matt  
noir, satiné mat  
zwart, zijdemat  
negro, mate seda  
preto, fosco sedoso  
nero, opaco seta  
svart, sidenmatt  
musta, silkinihmeä  
sort, silkematt  
sort, silkematt  
черный, шелковисто-матовый  
czarny, jedwabisto-matowy  
μαύρο, μεταξωτό ματ  
siyah, ipek mat  
černá, hedvābnē matnā  
fekete, selyemmatt  
črna, svila mat

## E

weiß, glänzend 4

white, gloss  
blanc, brillant  
wit, glansend  
branco, brillante  
branco, brilhante  
bianco, lucente  
vit, blank  
valkoinen, kiiltävä  
hvid, skinnende  
hvit, blank  
белый, блестящий  
biały, błyszczący  
λευκό, υαλιστερό  
beyaz, parlak  
bilá, lesklá  
fehér, fényes  
bela, bleskajoča

## G

steingrau, matt 75

stone grey, matt  
gris pierre, mat  
steengrijs, mat  
gris pizarra, mate  
cinzento pedra, fosco  
grigio roccia, opaco  
stengrå, matt  
kivenharmaa, himmeä  
stengrå, mat  
steingrå, matt  
серый каменный, матовый  
szary kamień, matowy  
γκρι πέτρας, ματ  
taş grisi, mat  
kamenň šedá, matnā  
kőszürke, matt  
kamen siva, mat

## H

aluminium, metallic 99

aluminium, metallic  
aluminium, métallique  
aluminium, metallic  
aluminio, metalizado  
aluminio, metálico  
aluminio, metalico  
aluminium, metallic  
alumiini, metallikiito  
aluminium, metallak  
aluminium, metallic  
алюминиевый, металл  
aluminium, metaliczny  
αλουμίνιου, μεταλλικό  
alüminyum, metalik  
hliníková, metaliza  
aluminium, metall  
aluminium, metalik

## I

anthrazit, matt 9

anthracite grey, matt  
anthracite, mat  
antraciet, mat  
antracita, mate  
antracite, fosco  
antracite, opaco  
antracit, matt  
antrasiitti, himmeä  
koksgrå, mat  
antrasit, matt  
антрацит, матовый  
antracyt, matowy  
ανθρακί, ματ  
antrasit, mat  
antracit, matnā  
tanno siva, mat

## J

eisen, metallic 91

steel, metallic  
coloris fer, métallique  
ijzerkleurig, metallic  
ferroso, metalizado  
ferro, metálico  
ferro, metalico  
järnfärg, metallic  
teräksenväriinen, metallikiito  
jern, metallak  
jern, metallic  
стальной, металл  
żelazo, metaliczny  
σιδηρού, μεταλλικό  
demír, metalik  
železná, metaliza  
vas, metall  
železna, metalik

## K

rot, klar 731

red, clear  
rouge, clair  
rood, helder  
rojo, claro  
vermelho, claro  
rosso, chiaro  
röd, klar  
punainen, kirkas  
röd  
красный  
czerwien  
κόκκινο, διαυγές  
kırmızı, şeffaf  
červená, čirá  
piros, áttetsző  
rdeča, jasna

## L

Blau, klar 752

Blue, clear  
Bleu, transparent  
Blauw, transparent  
Azul, transparente  
Azul, claro  
Blu, trasparente  
Blå, klar  
Sininen, kirkas  
Blå, klar  
Blå, klar  
Синий, прозрачный  
Niebieski, przejrzysty  
Mlæ, καθαρό  
Mavi, açık  
Kék, átlátszó  
Modrá, jasná

## 98 %

hellgrau, seidenmatt 371

light grey, silky-matt  
gris clair, satiné mat  
lichtgrijs, zijdemat  
gris claro, mate seda  
cinzento claro, fosco sedoso  
grigio chiaro, opaco seta  
lysegrå, sidenmatt  
vaaleanharmaa, silkinihmeä  
lysegrå, silkematt  
lysgrå, silkematt  
светло-серый, шелковисто-матовый  
jasnoszary, jedwabisto-matowy  
ανοιχτό γκρι, μεταξωτό ματ  
açık gri, ipek mat  
svētīēšēdā, hedvābnē matnā  
vilāgosszürke, selyemmatt  
svetlo siva, svila mat

## M

## 2 %

patinagrün, seidenmatt 365

patina green, silky-matt  
vert patine, satiné mat  
patinagroen, zijdemat  
verde patina, mate seda  
verde patina, fosco sedoso  
verde patina, opaco seta  
patinagrön, sidenmatt  
patinavhrea, silkinihmeä  
patinagrön, silkematt  
patinagrön, silkematt  
зеленый патина, шелк.-матовый  
zielony-patyna, jedwabisto-matowy  
πράσινο ενυ. σκουριάς, μετ. ματ  
limon küfü, ipek mat  
patinová zelená, hedvābnē matnā  
patinazöld, selyemmatt  
staro zelena, svila mat

## N

leuchtorange, matt 25

luminous orange, matt  
orange voyant, mat  
lichtoranje, mat  
naranja fosfor, mate  
laranja fosforec, fosco  
arancione chiaro, opaco  
lysorange, matt  
hóthoráncsi, himmeä  
lysende orange, mat  
lysende orange, matt  
оранжевый светящийся, матовый  
pomarańczowy świecący, matowy  
πορτοκαλί φωτεινό, ματ  
açık portakal, mat  
svítici oranžová  
világító narancs, matt  
svetlo pomorandžast, mat

## O

feuerrot, glänzend 31

fiery red, gloss  
rouge feu, brillant  
rood helder, glansend  
rojo fuego, brillante  
vermelho vivo, brilhante  
rosso fuoco, lucente  
eldröd, blank  
tulipunainen, kiiltävä  
ildröd, skinnende  
ildröd, blank  
огненно-красный, блестящий  
szermwony ognisty, błyszczący  
κόκκινο φωτιάς, υαλιστερό  
ateş kırmızısı, parlak  
ohnivě červená, lesklá  
tűzpiros, fényes  
ogęńj rdeča, bleskajoča

## 75 %

## P

## 25 %

eisen, metallic 91 +  
steel, metallic  
coloris fer, métallique  
ijzerkleurig, metallic  
ferroso, metalizado  
ferro, metálico  
ferro, metalico  
järnfärg, metallic  
teräksenväriinen, metallikiito  
jern, metallak  
jern, metallic  
стальной, металл  
żelazo, metaliczny  
σιδηρού, μεταλλικό  
demír, metalik  
železná, metaliza  
vas, metall  
železna, metalik

rost, matt 83

rust, matt  
rouille, mat  
roest, mat  
orin, mate  
ferrugem, fosco  
color ruggine, opaco  
rost, matt  
ruoste, himmeä  
rust, mat  
rust, matt  
ржавчина, матовый  
rdzawy, matowy  
χρώμα σκουριάς, ματ  
pas rengi, mat  
rezavá, matnā  
rozśda, matt  
rjava, mat

## R

gelb, glänzend 12

yellow, gloss  
jaune, brillant  
geel, glansend  
amarillo, brillante  
amarelo, brilhante  
giallo, lucente  
gul, blank  
keltainen, kiiltävä  
gul, skinnende  
gul, blank  
желтый, блестящий  
żółty, błyszczący  
κίτρινο, υαλιστερό  
sarı, parlak  
žlutá, lesklá  
sárga, fényes  
rumena, bleskajoča

## S

dunkelgrau, seidenmatt 378

dark grey, silky-matt  
gris foncé, satiné mat  
donkergrijs, zijdemat  
gris oscuro, mate seda  
cinzento escuro, fosco sedoso  
grigio scuro, opaco seta  
mörkgrå, sidenmatt  
harmaa, silkinihmeä  
mørkegrå, silkematt  
серый, шелковисто-матовый  
szary, jedwabisto-matowy  
γκρι, μεταξωτό ματ  
gri, ipek mat  
šedá, hedvābnē matnā  
szürke, selyemmatt  
siva, svila mat

## T

silber, metallic 90

silver, metallic  
argent, métallique  
zilver, metallic  
plata, metalizado  
prata, metálico  
argento, metalico  
silver, metallic  
hopea, metallikiito  
sølv, metallak  
sølv, metallic  
серебристый, металл  
srebro, metaliczny  
οσημί, μεταλλικό  
gümüş, metalik  
ezüst, metall  
srebrna, metalik

## W

orange, glänzend 30

orange, gloss  
orange, brillant  
oranje, glansend  
naranja, brillante  
naranja, brilhante  
arancione, lucente  
orange, blank  
oranssi, kiiltävä  
orange, skinnende  
orange, blank  
оранжевый, блестящий  
pomarańczowy, błyszczący  
πορτοκαλί, υαλιστερό  
portakal, parlak  
oranžová, lesklá  
narancsszínű, fényes  
pomorandžast, bleskajoča

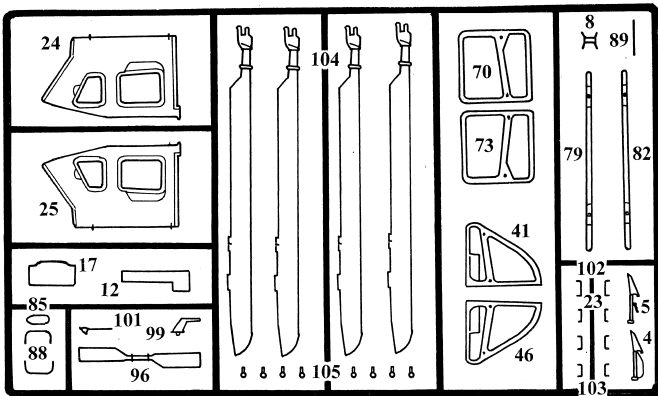
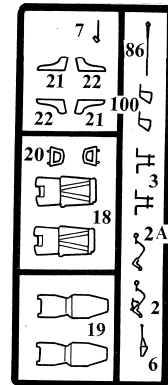
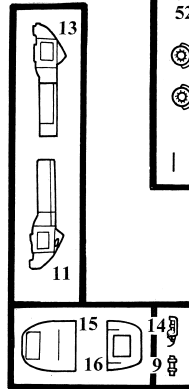
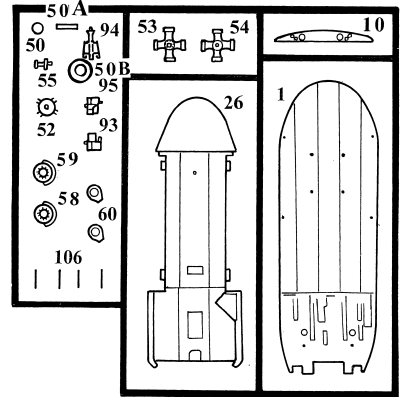
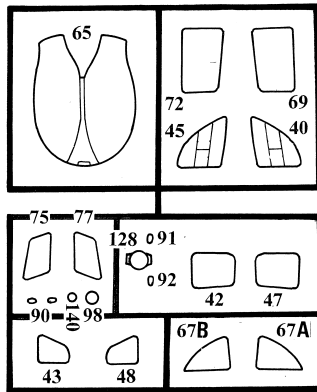
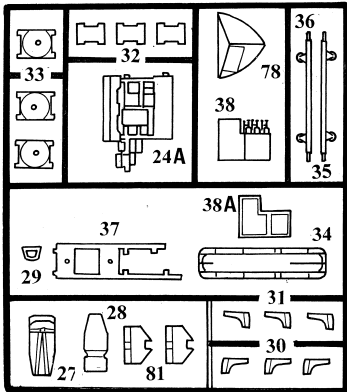
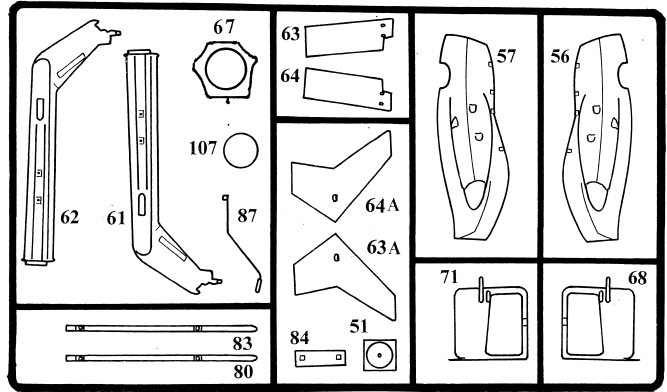
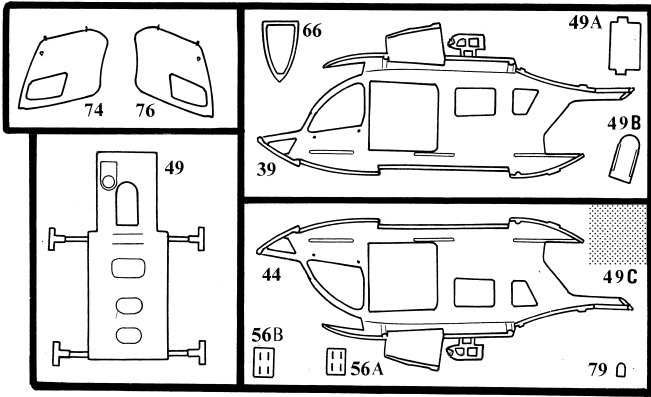

Nicht benötigte Teile  
 Parts not used  
 Pièces non utilisées  
 Niet benodigde onderdelen  
 Piezas no necesarias  
 Peças não utilizadas  
 Parti non usate  
 Inte använda delar  
 Tarpeetomat osat  
 Ikke nødvendige dele  
 Deler som ikke er nødvendige  
 Неиспользованные детали  
 Elementy niepotrzebne  
 μη χρειαζούμενα εξαρτήματα  
 Gereksiz parçalar  
 Nepotrebné dily  
 fel nem használt alkatrészek  
 Nepotrební deli

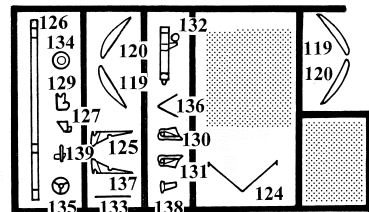
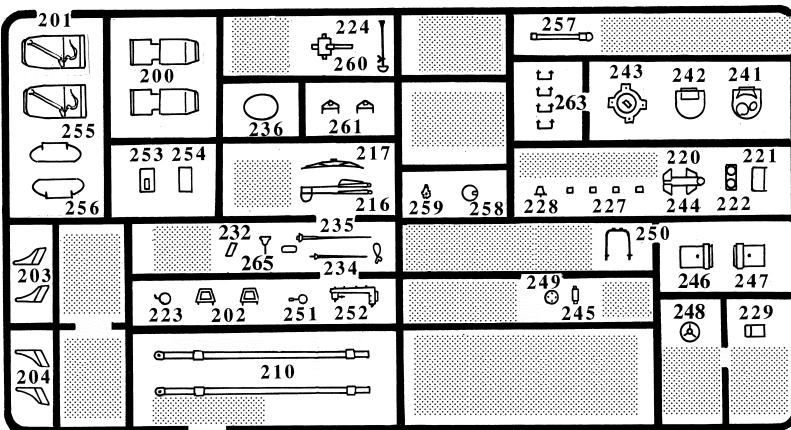

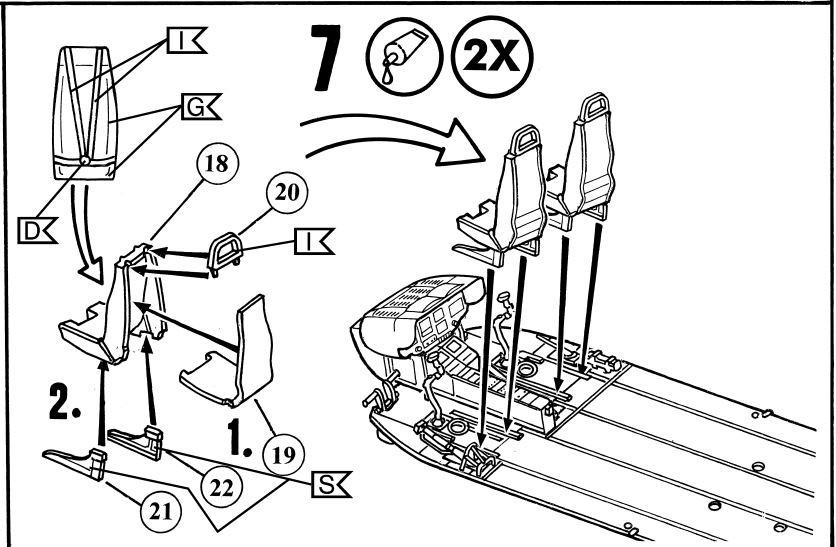
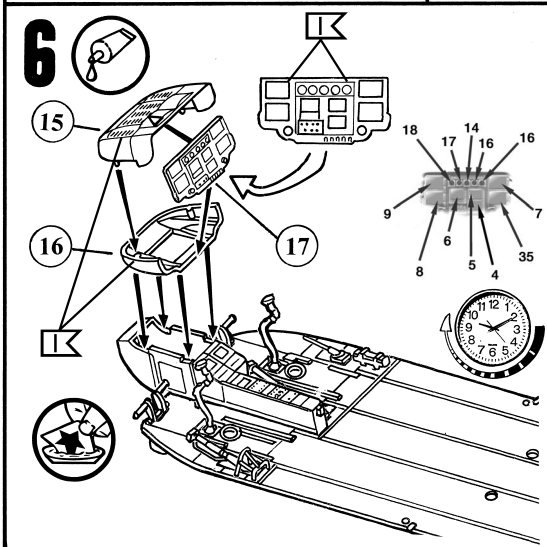
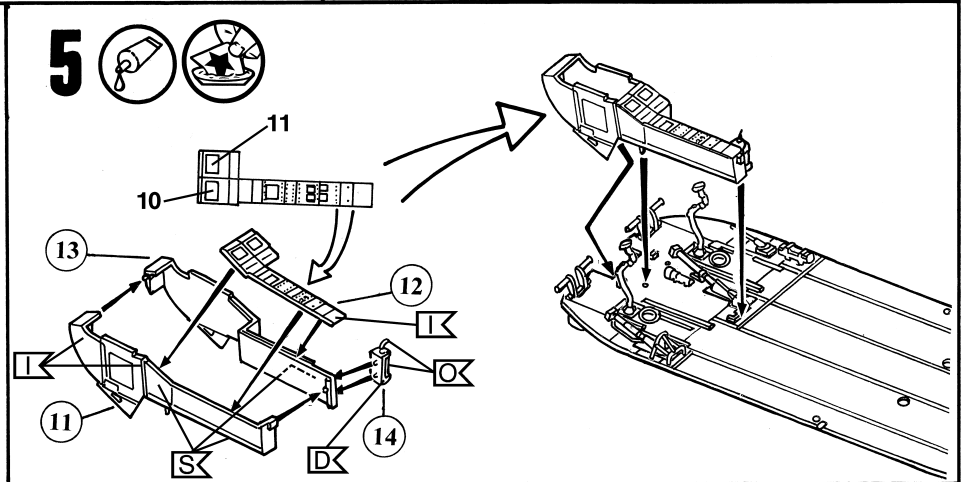
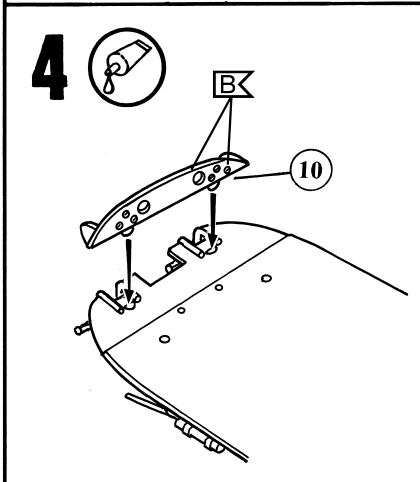
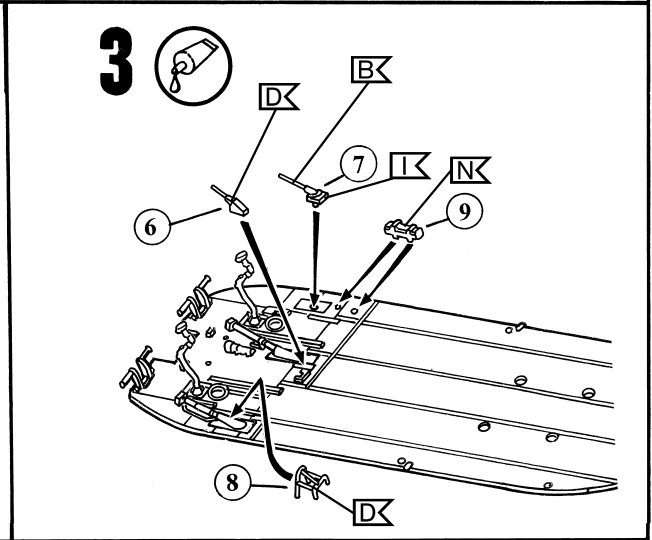
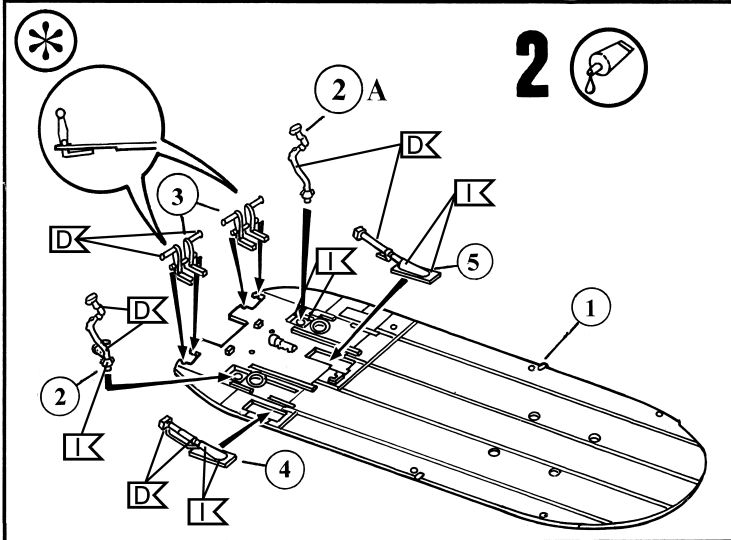
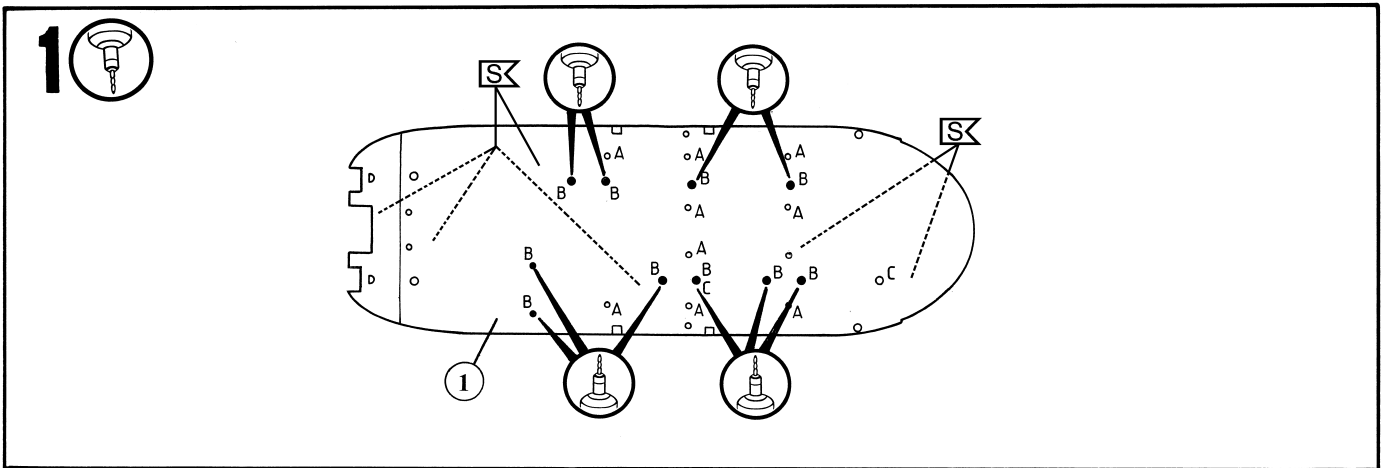

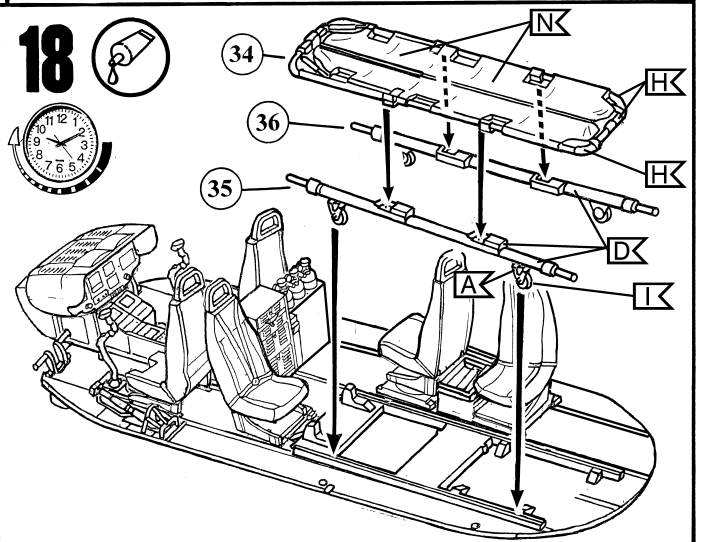
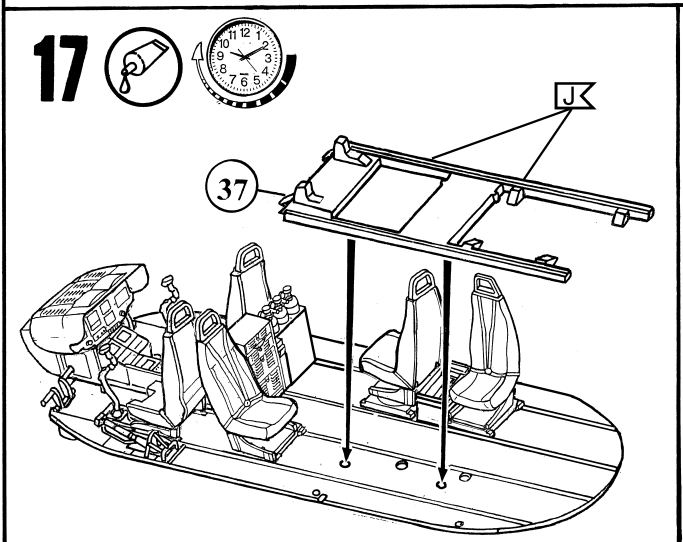
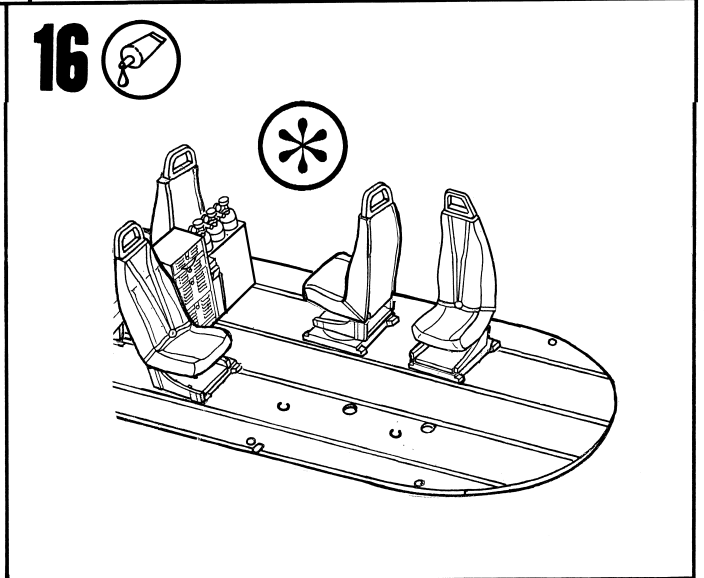
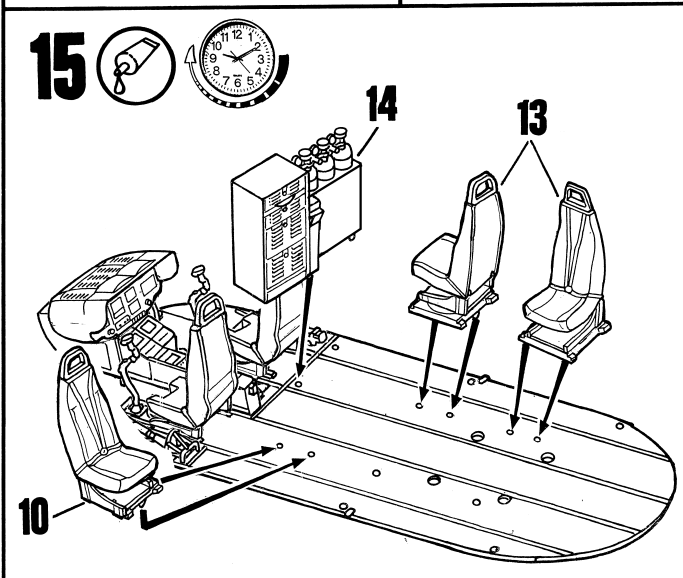
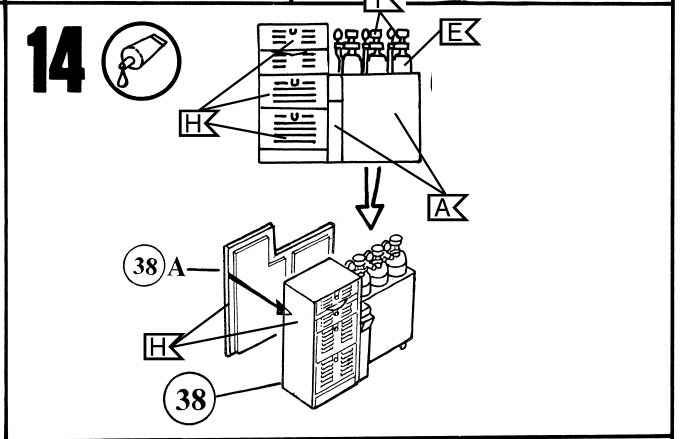
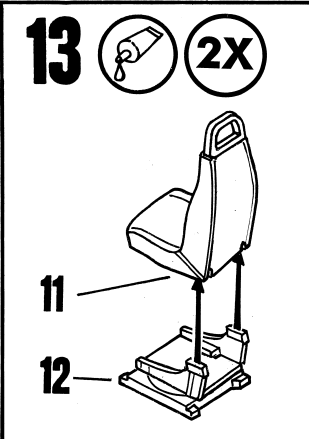
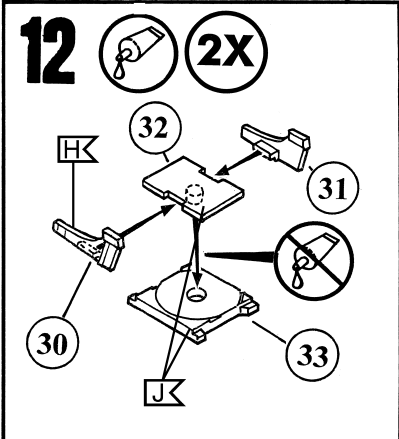
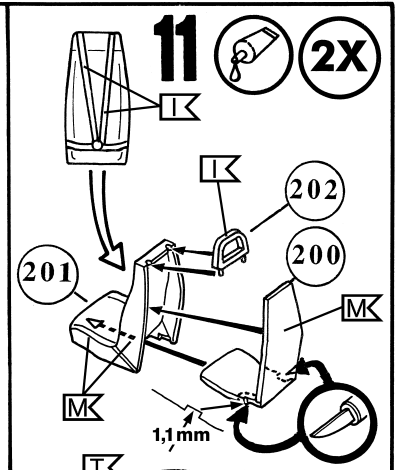
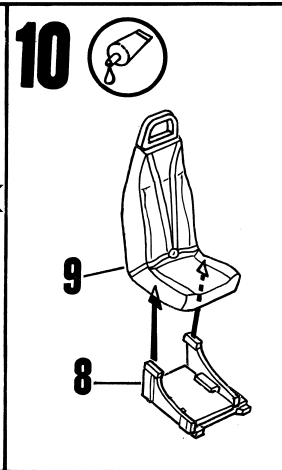
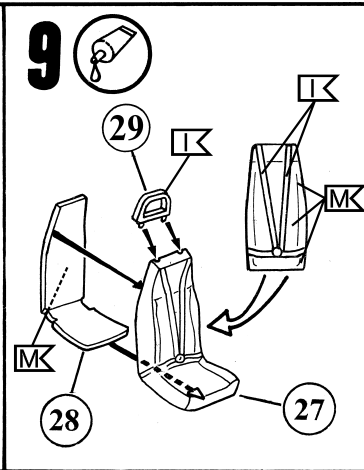
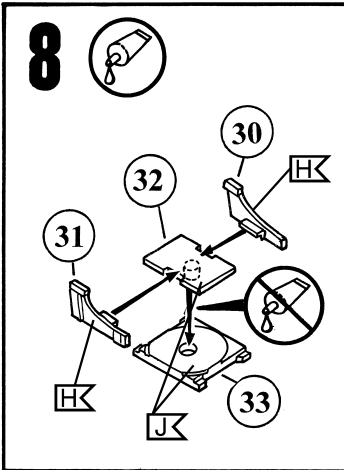

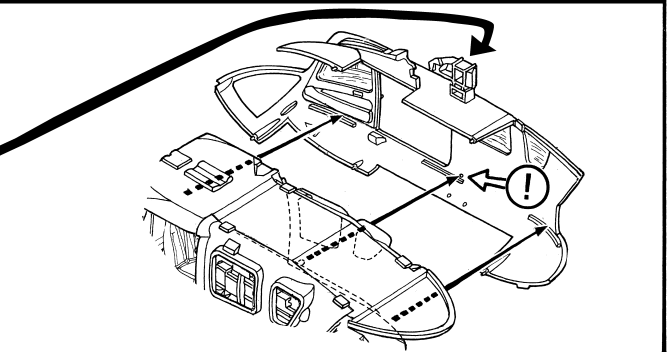
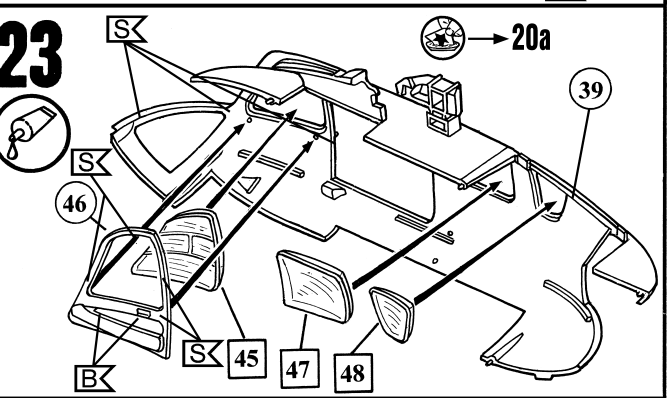
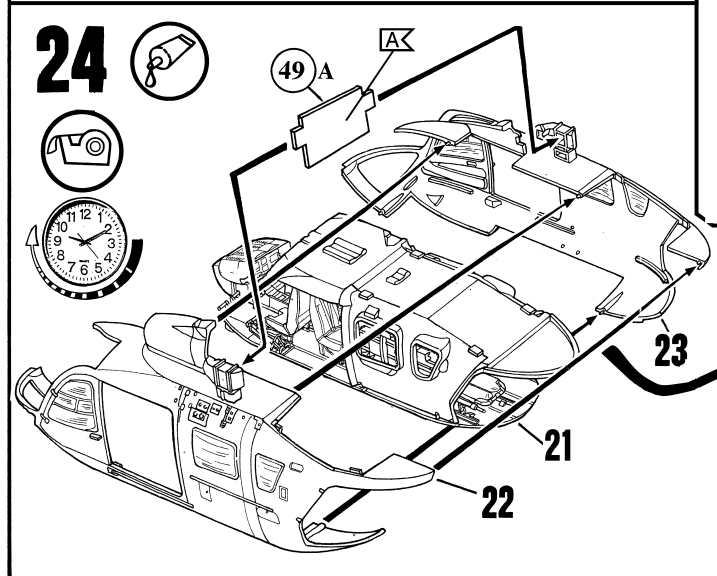
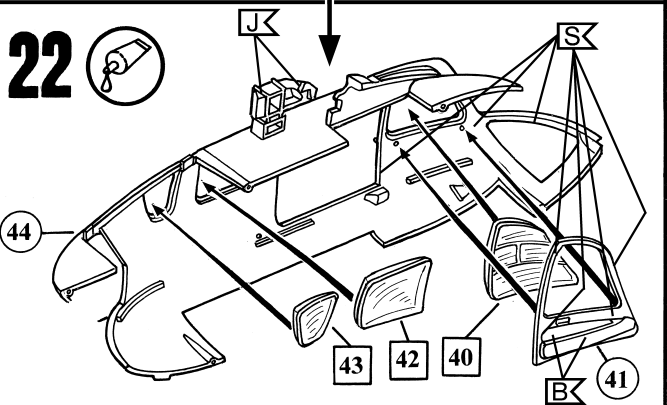
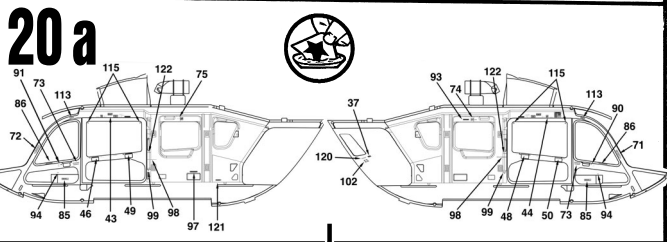
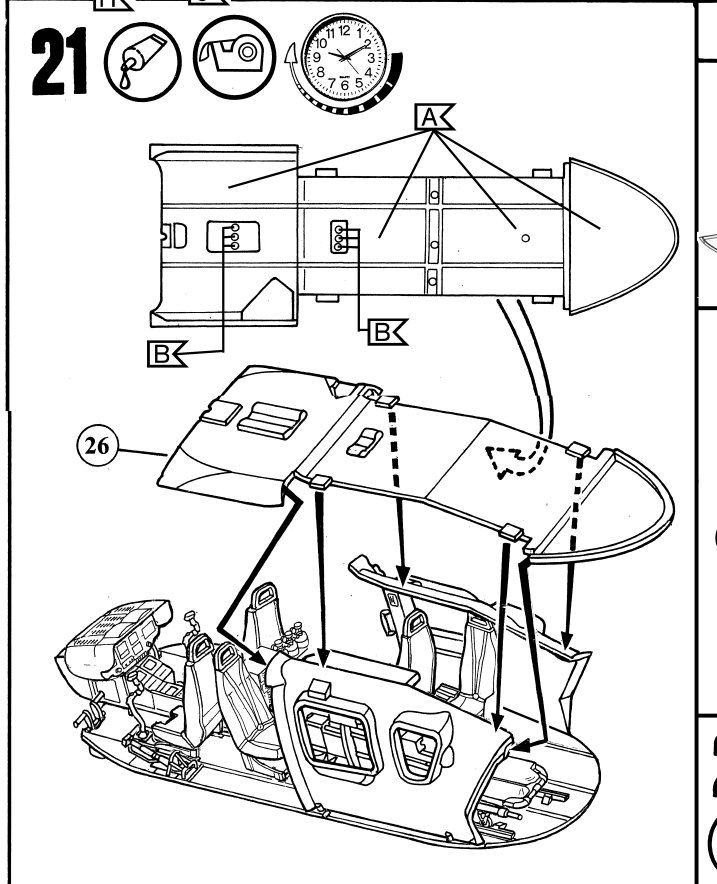
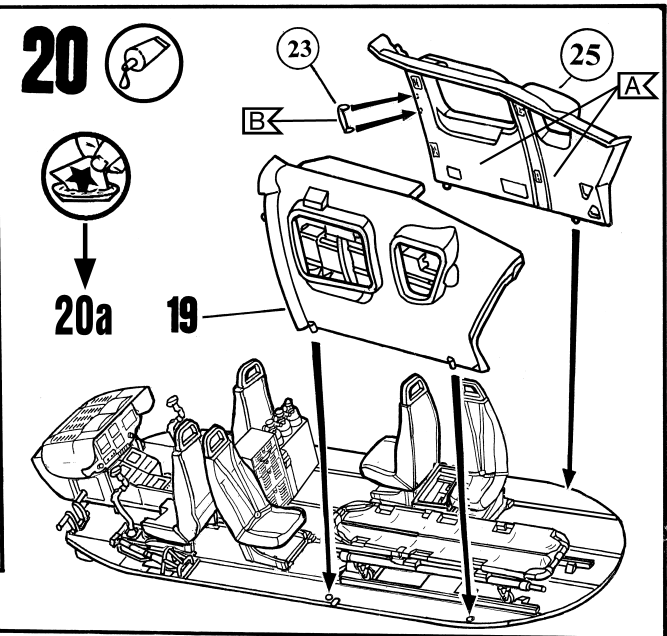
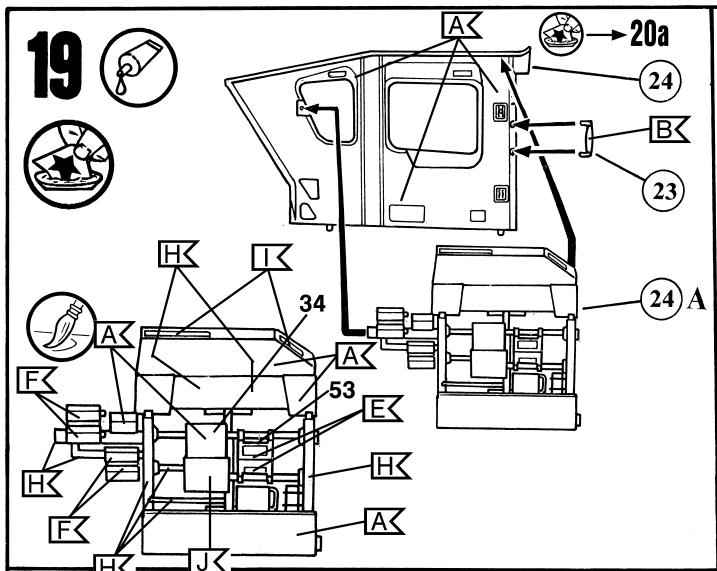



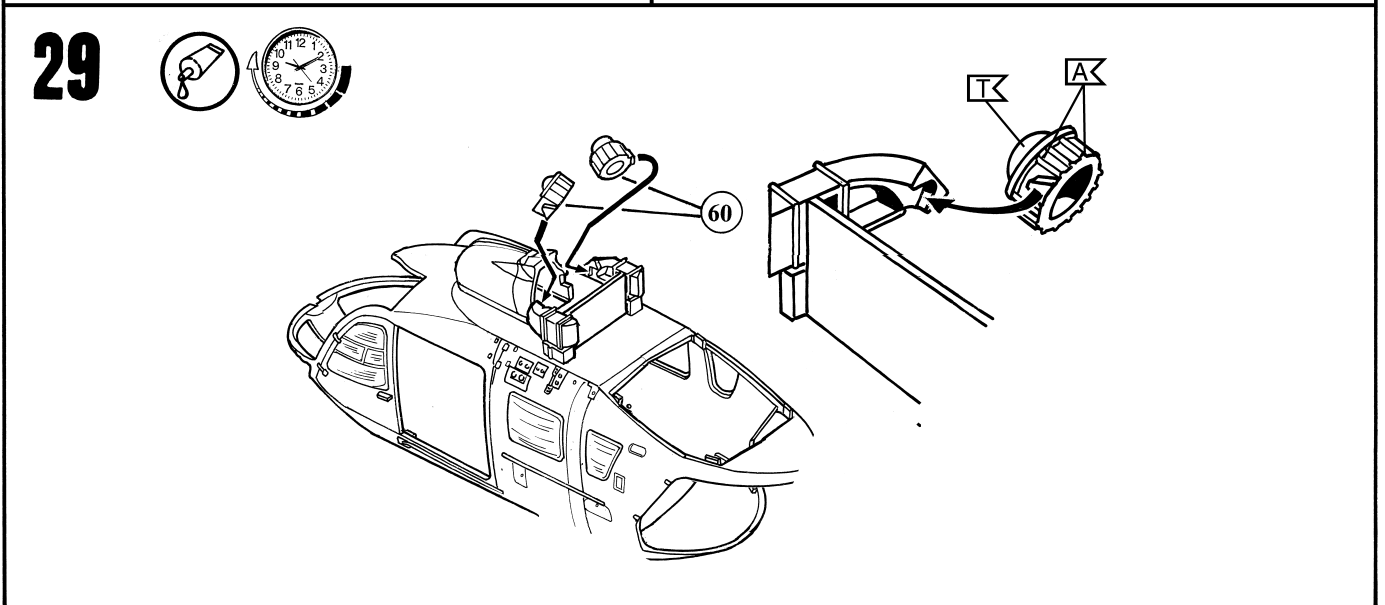
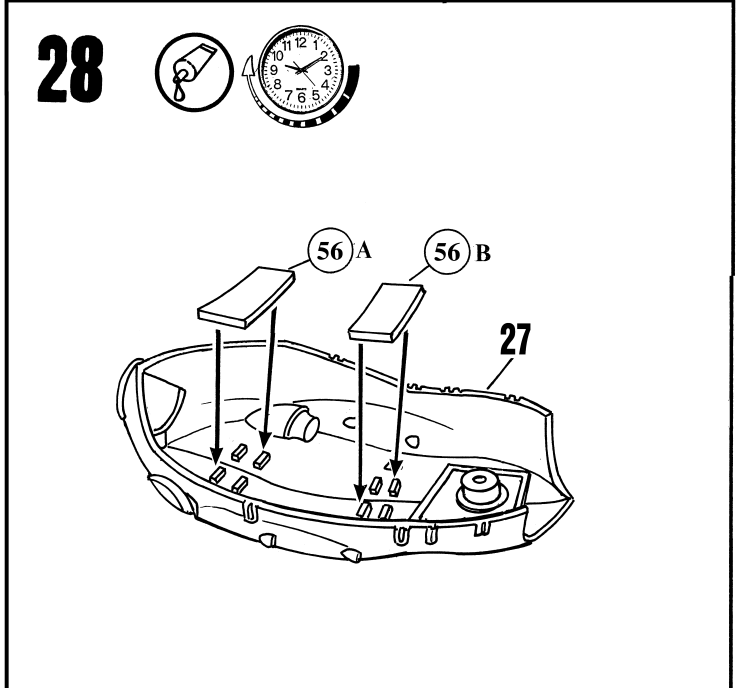
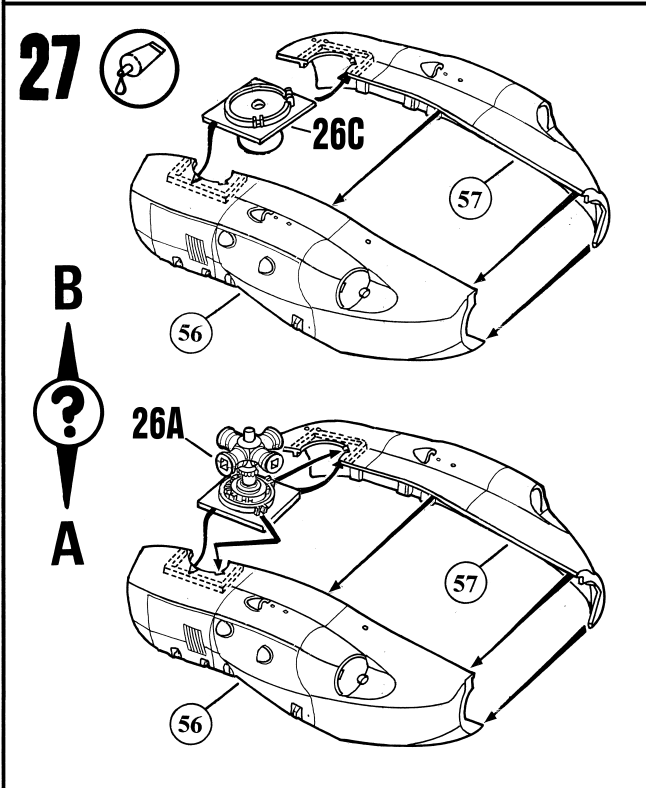
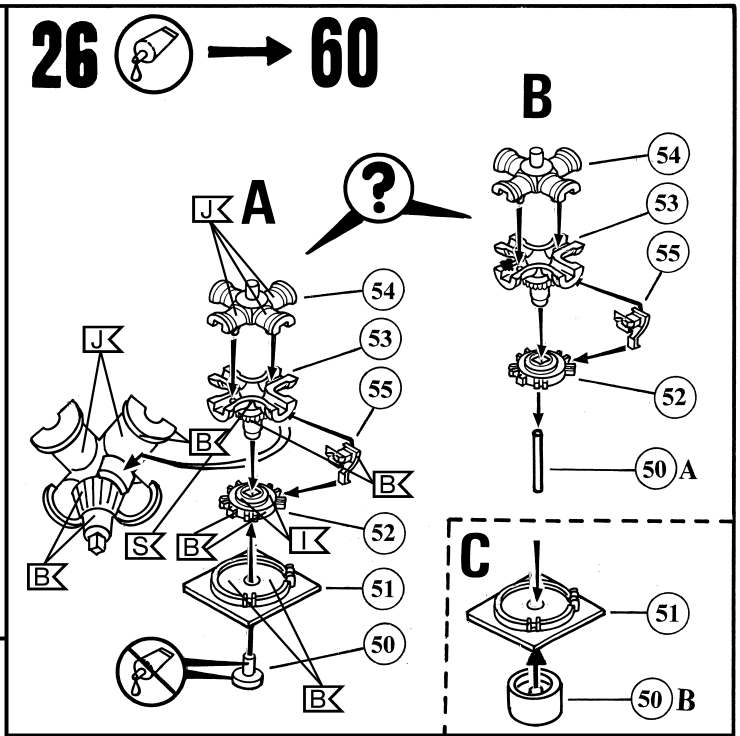
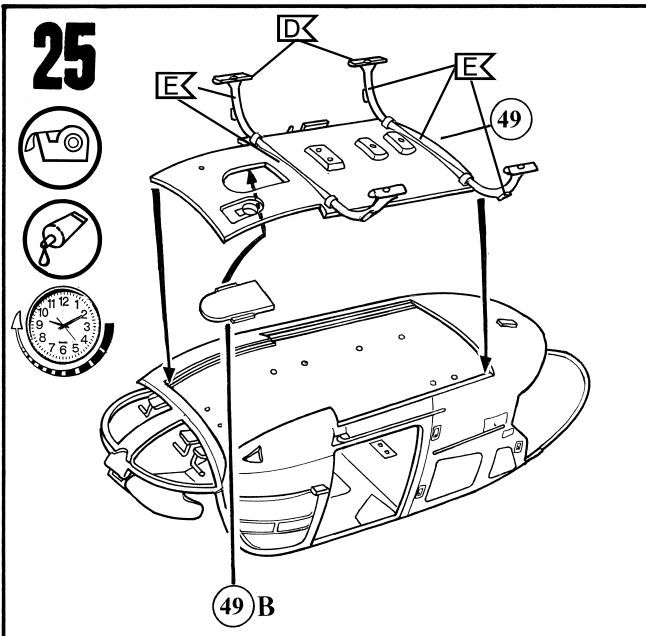

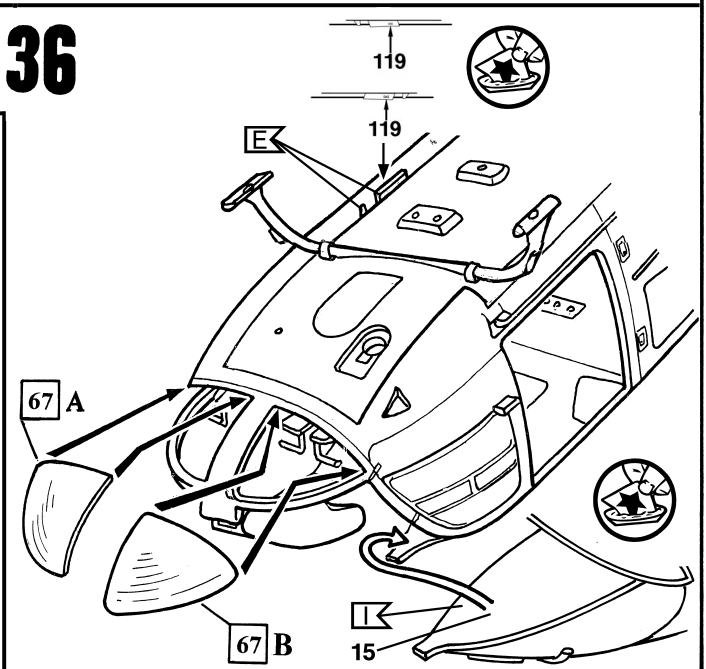
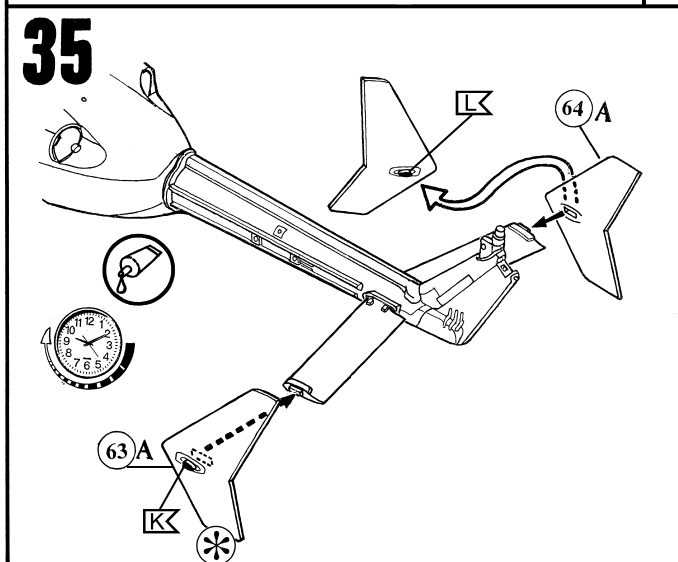
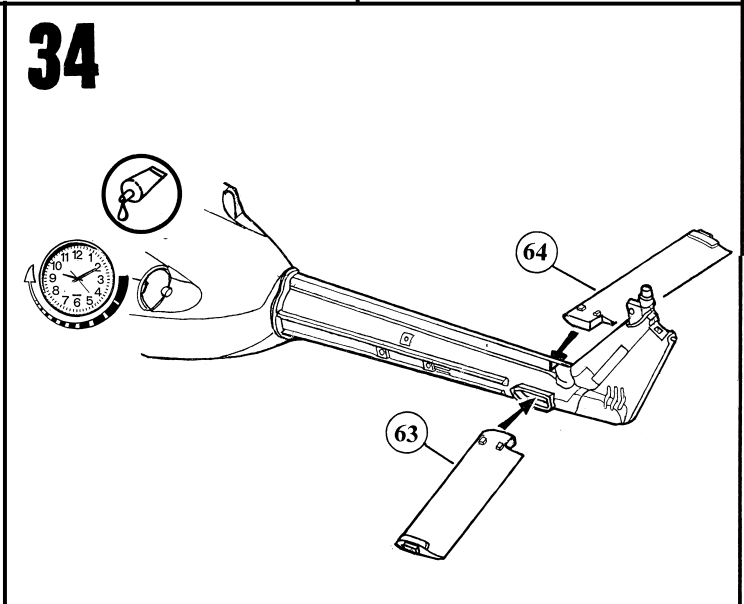
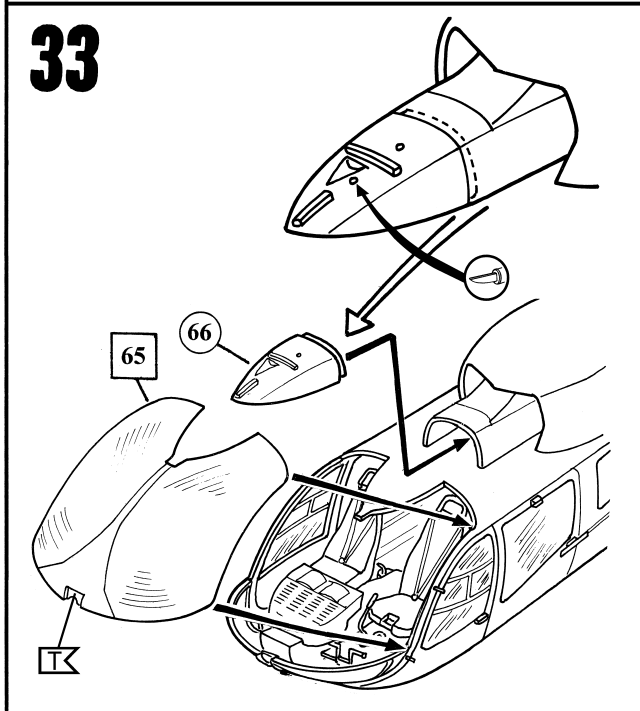
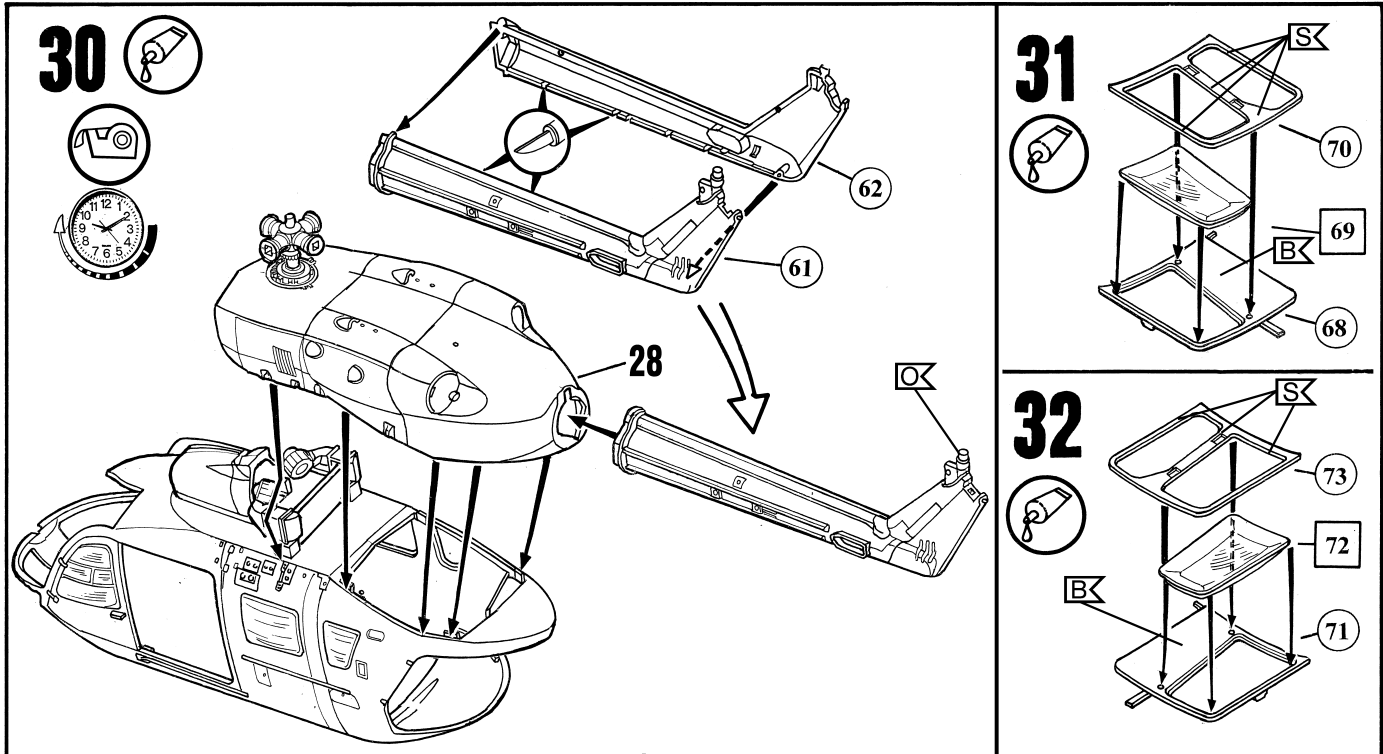

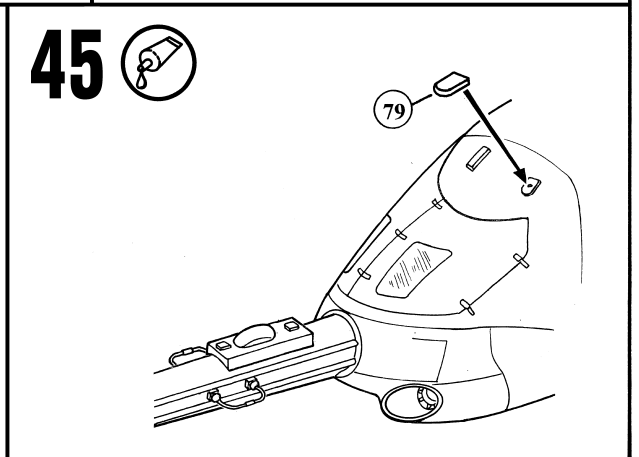
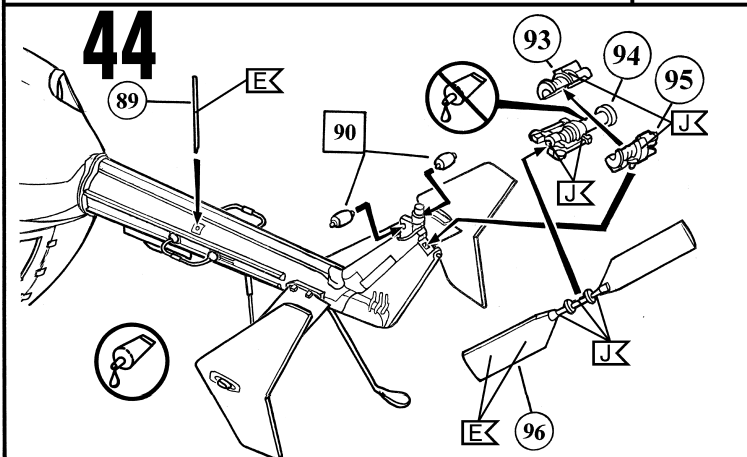
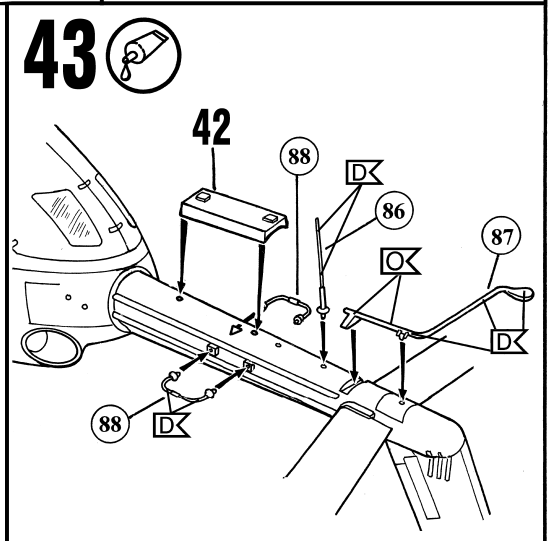
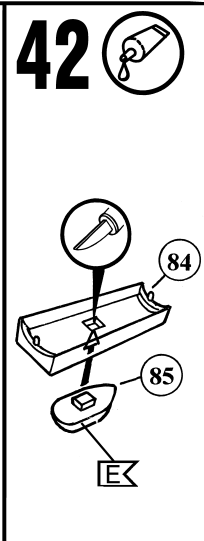
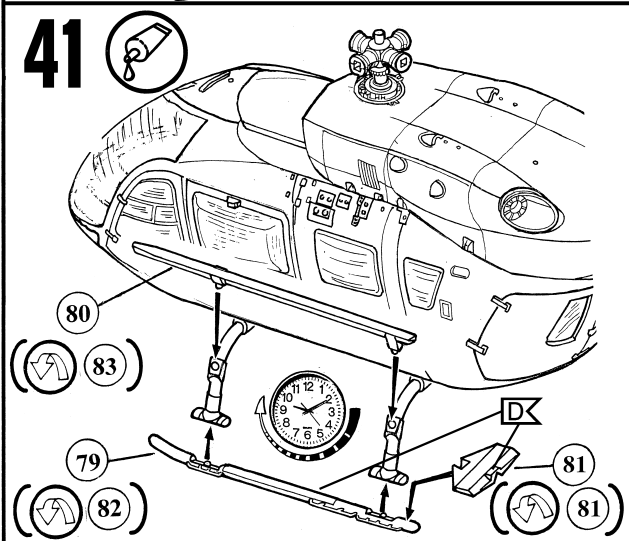
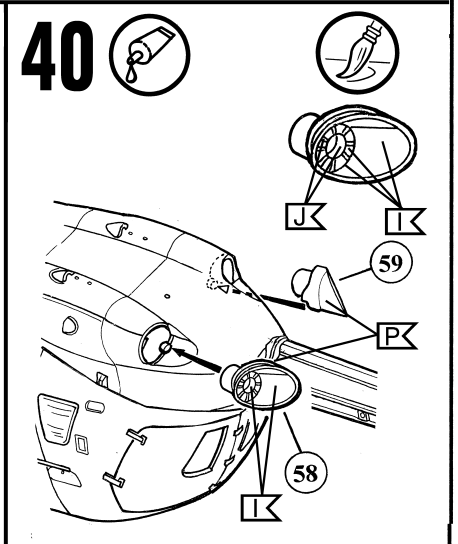
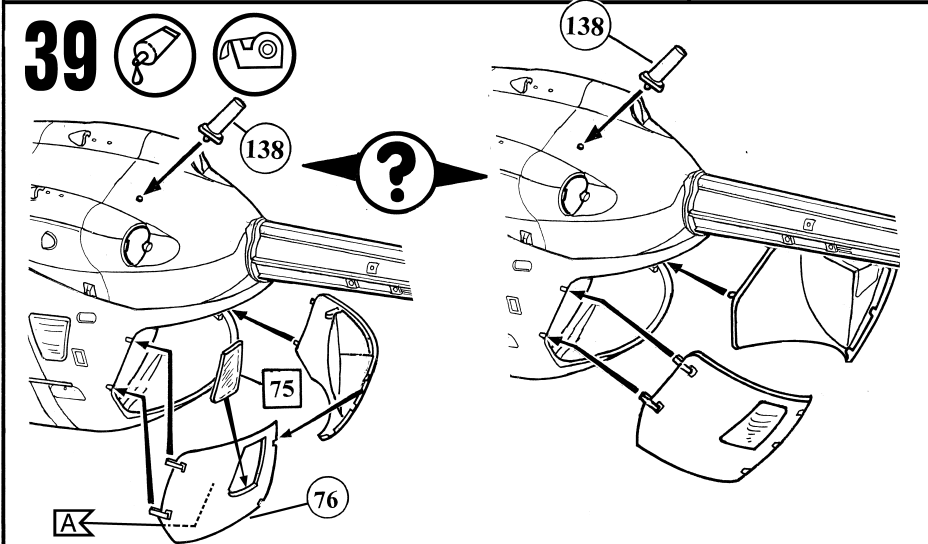
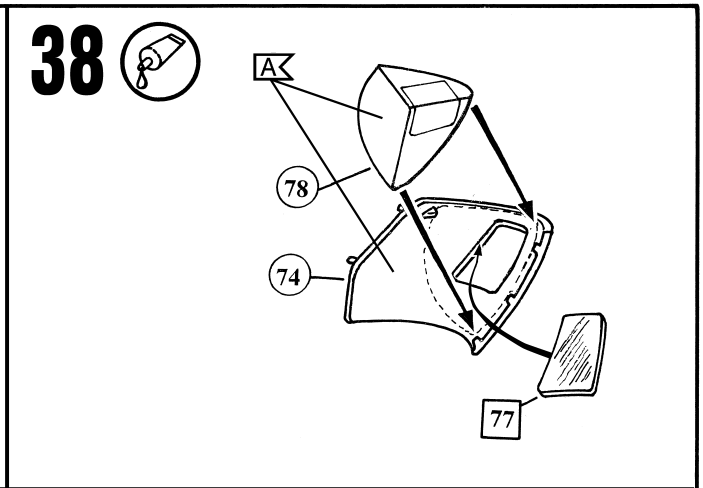
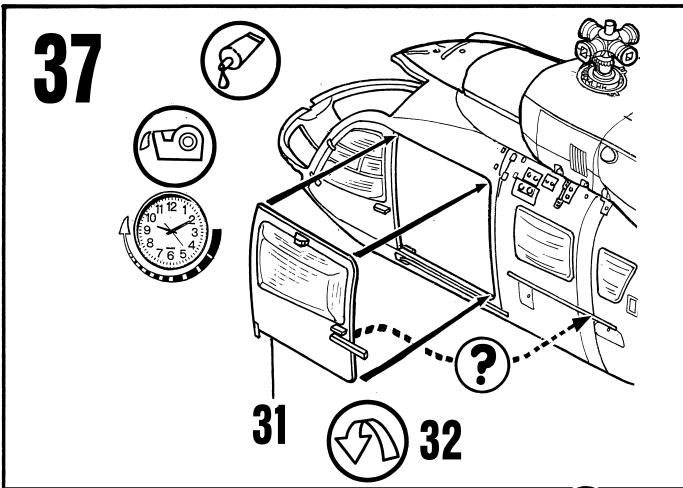

46

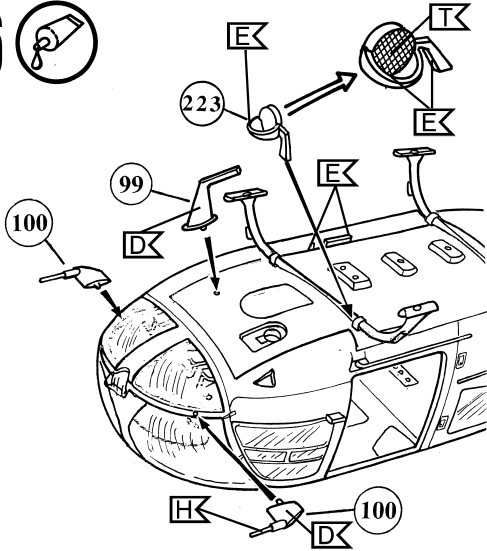

47

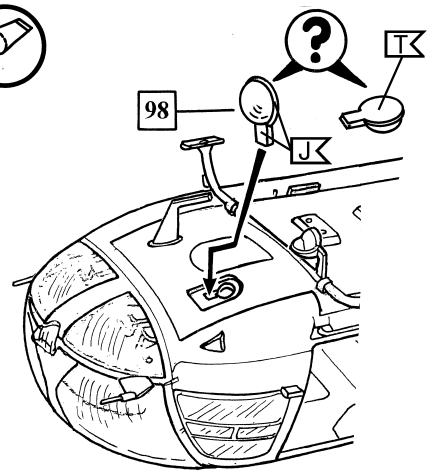

48

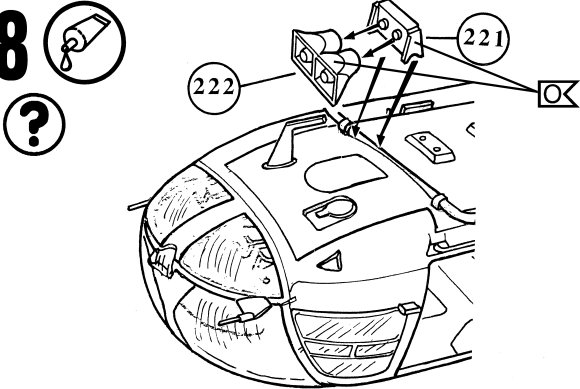

49

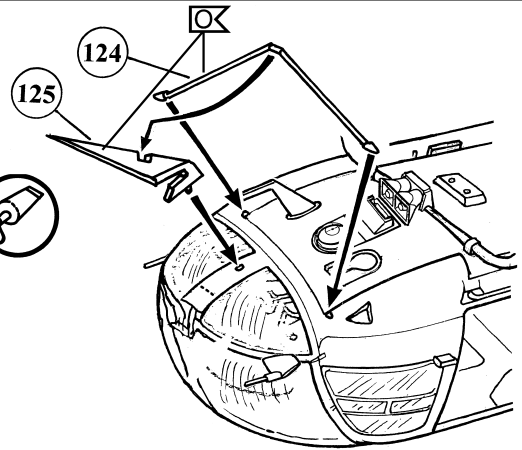

50

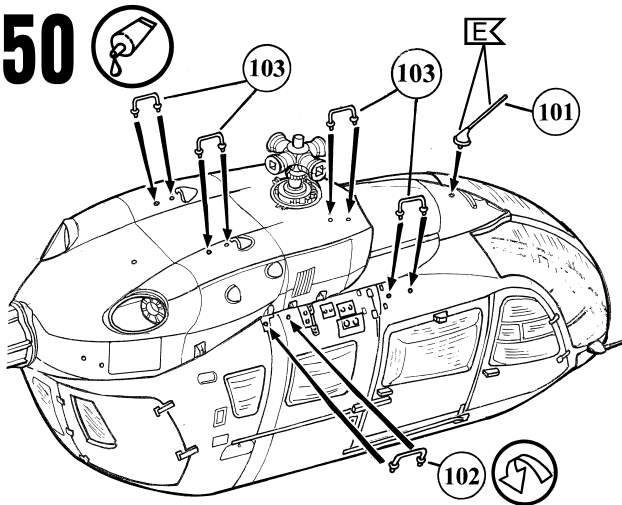

51

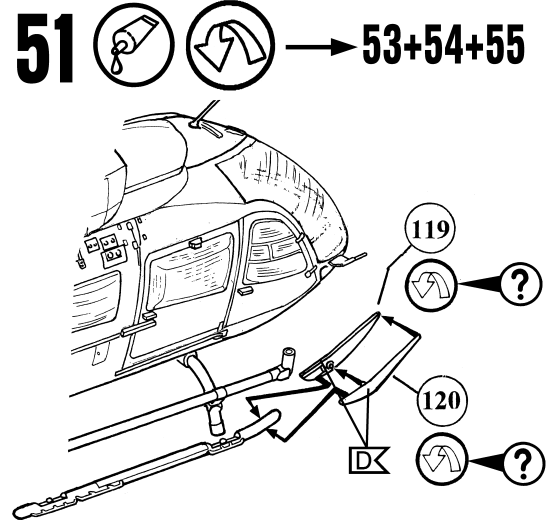

52

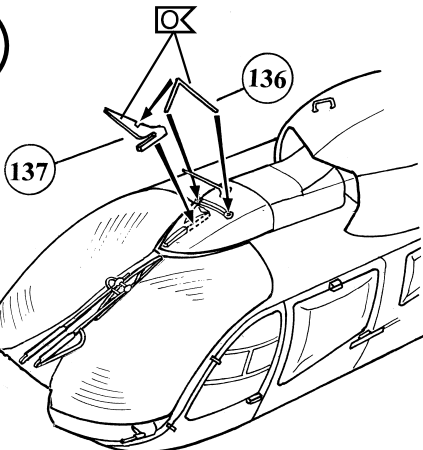

53

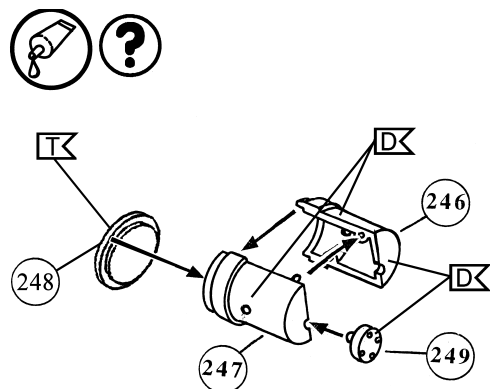

# 54

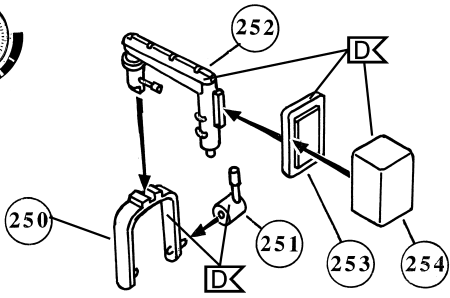

# 55



64

63

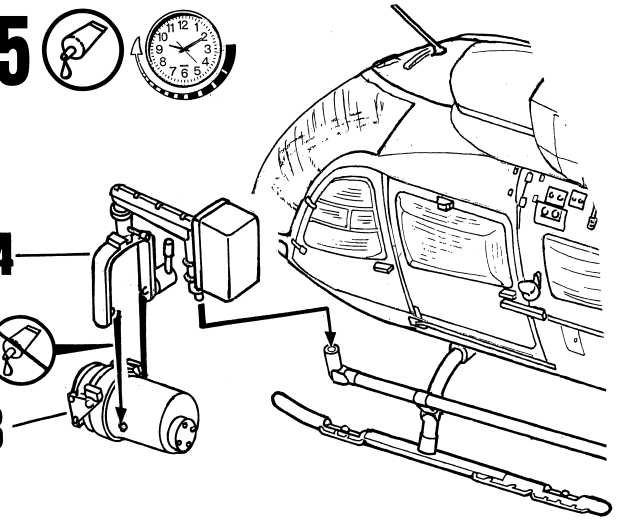

# 56

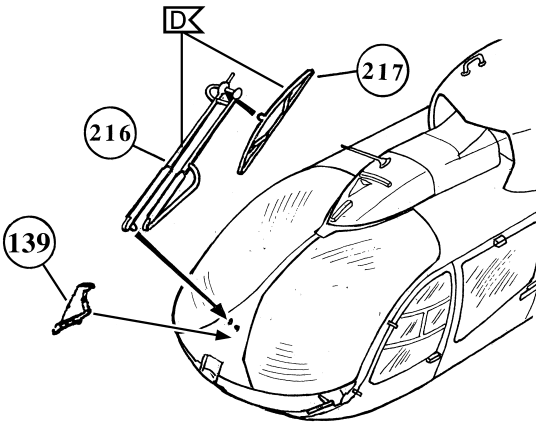

# 57

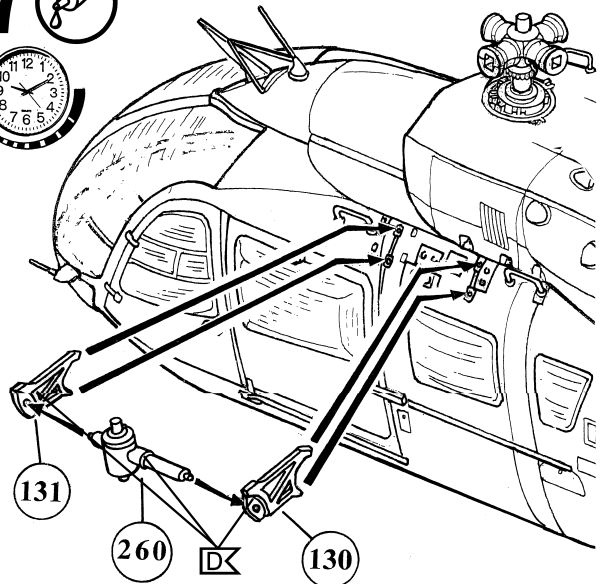

# 58

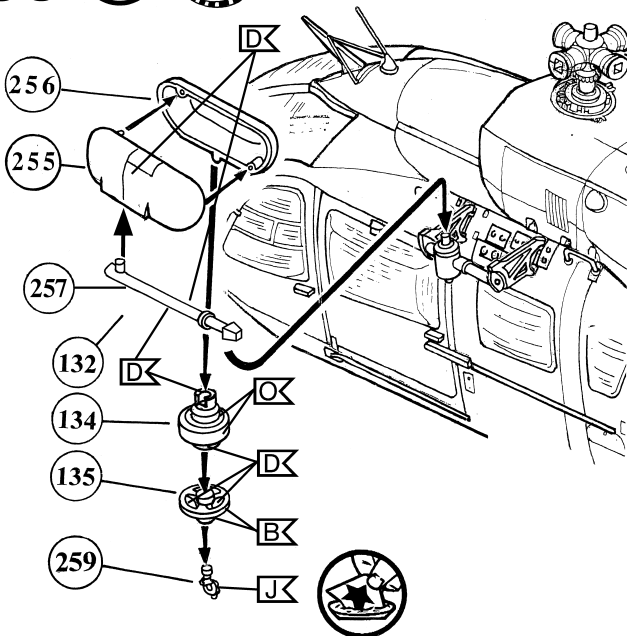
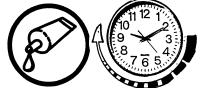

# 59

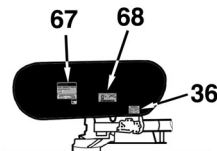
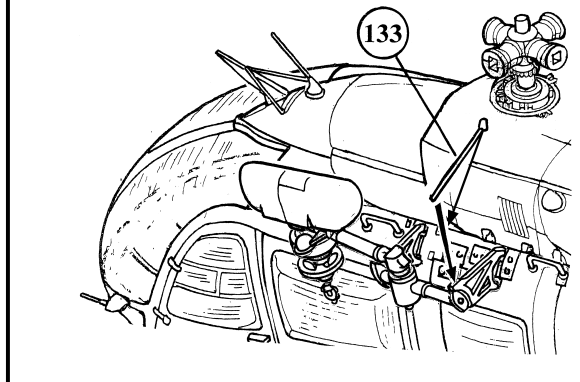

Winch - Backside-Markings

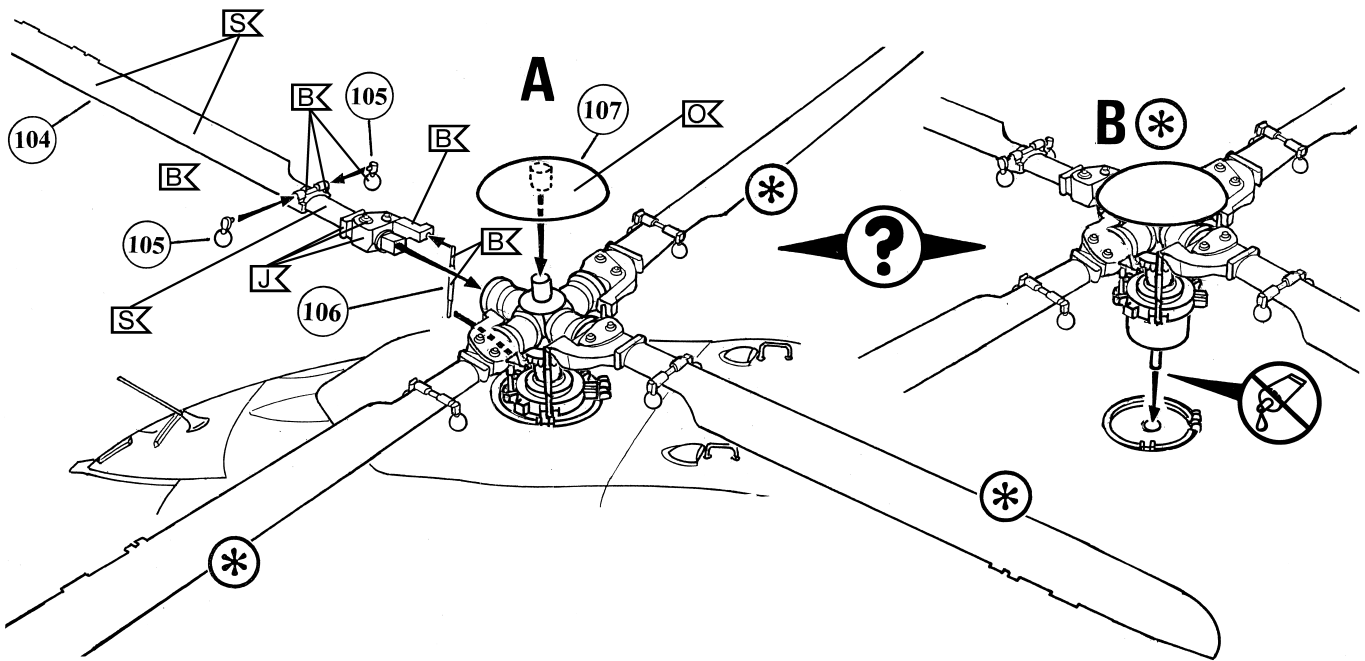
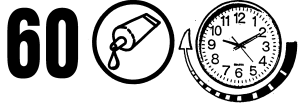

Underside

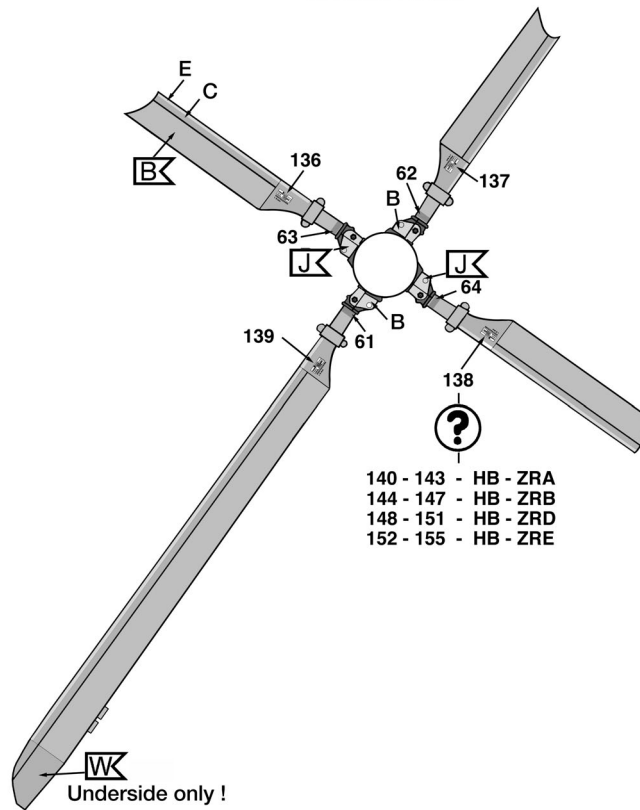

- 140 - 143 - HB - ZRA
- 144 - 147 - HB - ZRB
- 148 - 151 - HB - ZRD
- 152 - 155 - HB - ZRE

# 62



## Eurocopter EC 145 Rega, Switzerland, 2005

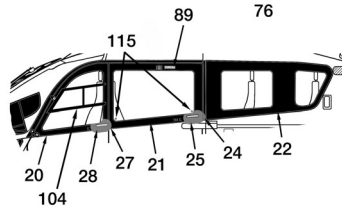
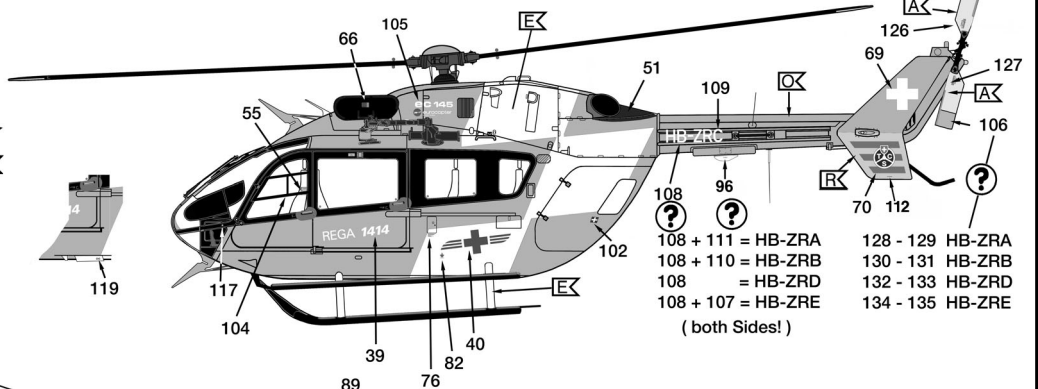
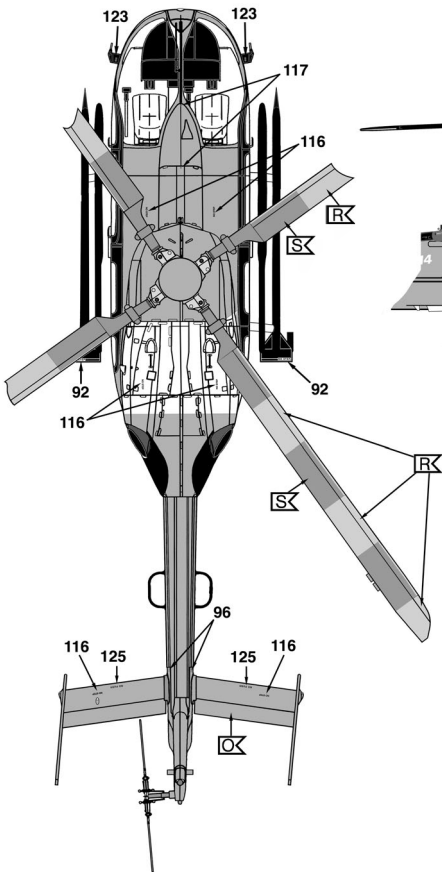
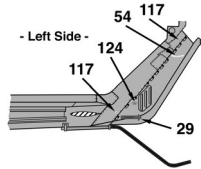

Zürich - Dübendorf, only !

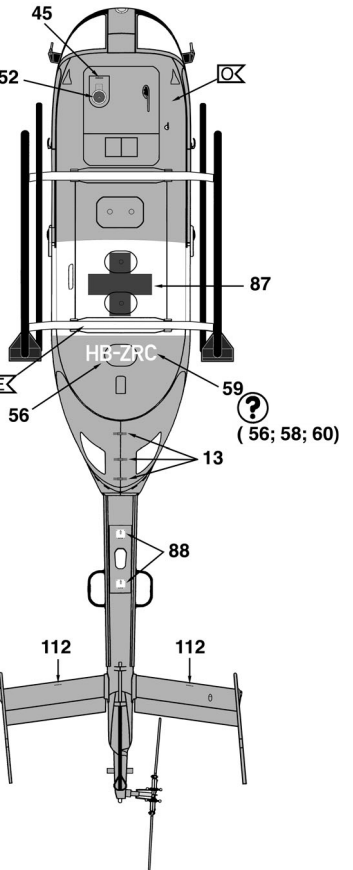

- 108 + 111 = HB-ZRA
- 108 + 110 = HB-ZRB
- 108 = HB-ZRD
- 108 + 107 = HB-ZRE (both Sides!)
- 128 - 129 HB-ZRA
- 130 - 131 HB-ZRB
- 132 - 133 HB-ZRD
- 134 - 135 HB-ZRE

