

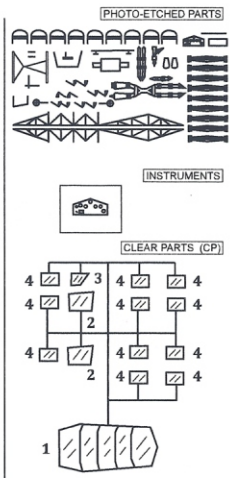

DFS 230 (Unternehmen Eiche)

scale 1/72

DFS 230 byl nákladní kluzák německé Luftwaffe během druhé světové války. Vyvinut a vyráběn byl Deutsche Forschungsanstalt für Segelflug (DFS - Německý výzkumný ústav bezmotorového létání) pod vedením konstruktéra Hanse Jacobse. Německý kluzák se později stal inspirací pro britský kluzák Horsa. V leteckém závodě Českomoravských strojů v Praze-Karlíně bylo za války vyrobeno dle různých zdrojů 450 až 500 kusů těchto kluzáků. The DFS 230 was a German transport glider operated by the Luftwaffe in World War II. It was developed in 1933 by the Deutsche Forschungsanstalt für Segelflug (DFS - "German Research Institute for Sailplane Flight") with Hans Jacobs as the head designer. The glider was the German inspiration for the British Horsa glider and was intended for paratrooper assault operations.

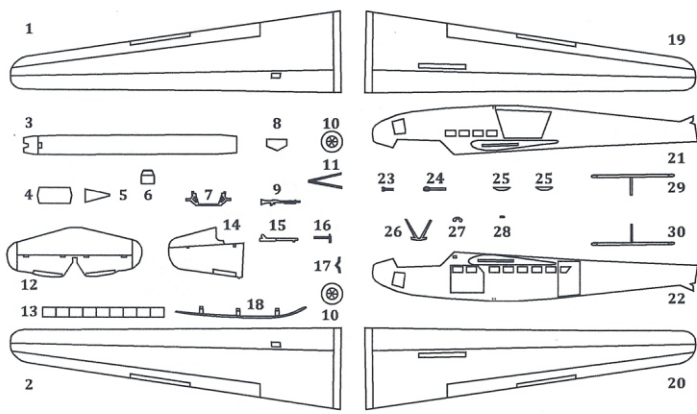

- | | | | |
|-----------------------------|--------------------------|------------------------|------------------------------|
| A Černá Black | C Kůže Leather | E RLM 02 | G Kovová Gun metal |
| B Stříbrná Silver | D Plátno Linen | F Bílá White | H Barva pneu Tyres |

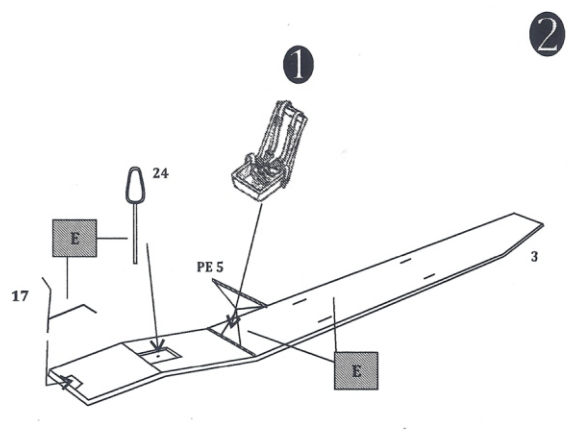
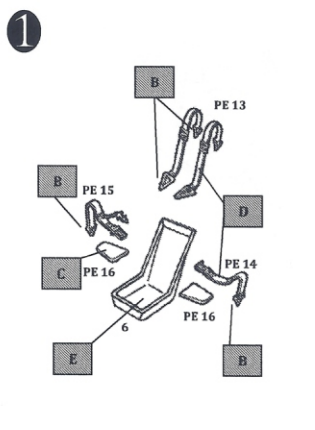

92172

3

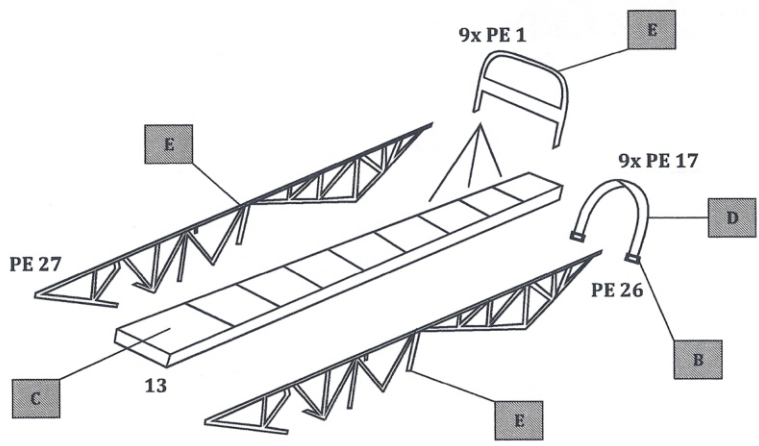
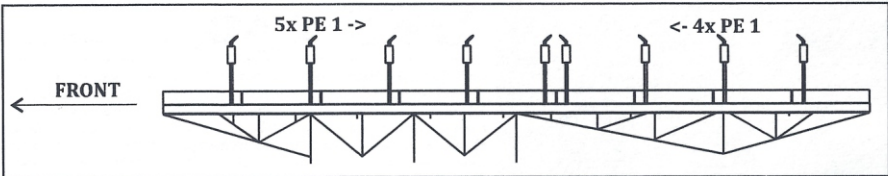

4

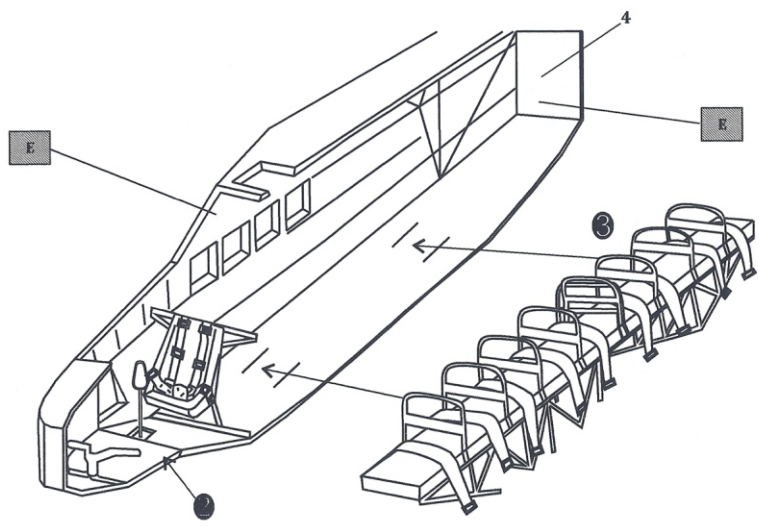

5

Palubní deska
Instrument panel

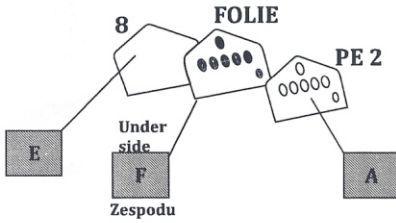

6

Střeliště
Gunner stand

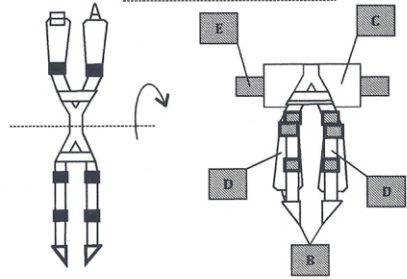

7

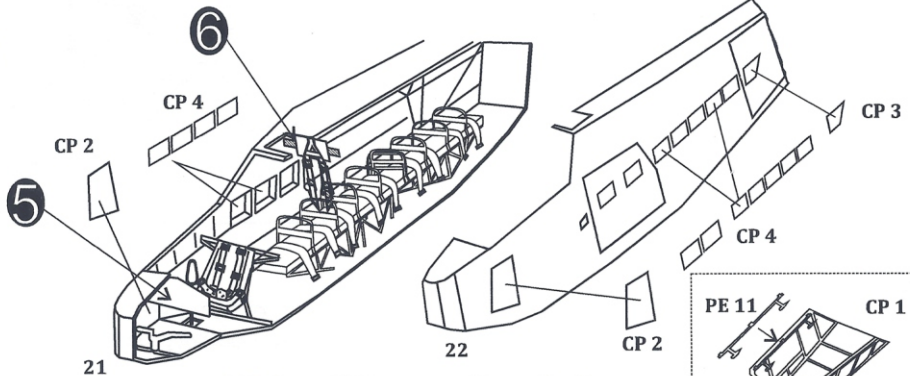

CP 3 použít jen u markingu č. 2!
CP 3, use only at marking no. 2!

8

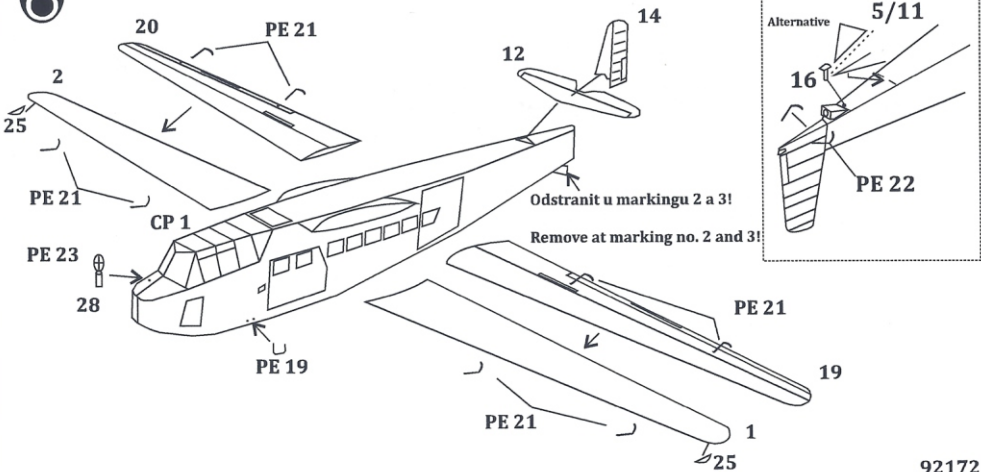

92172

9

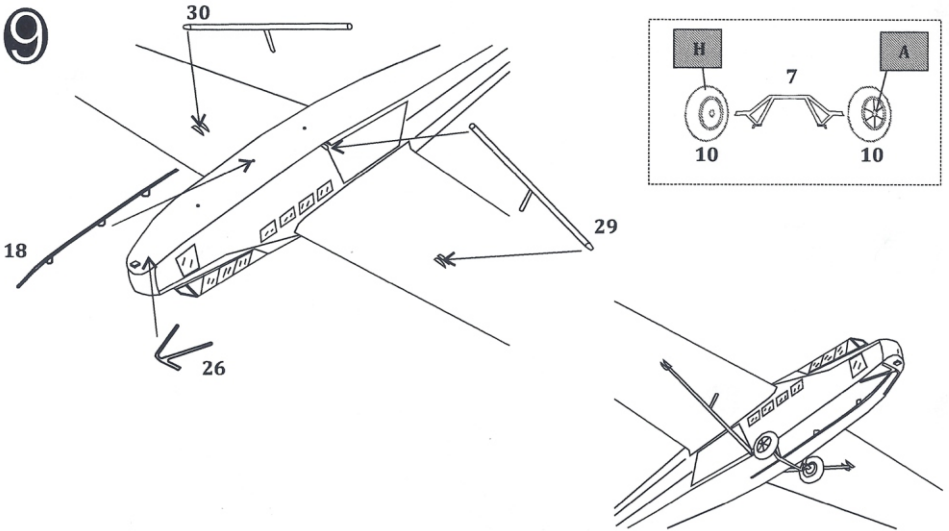

10

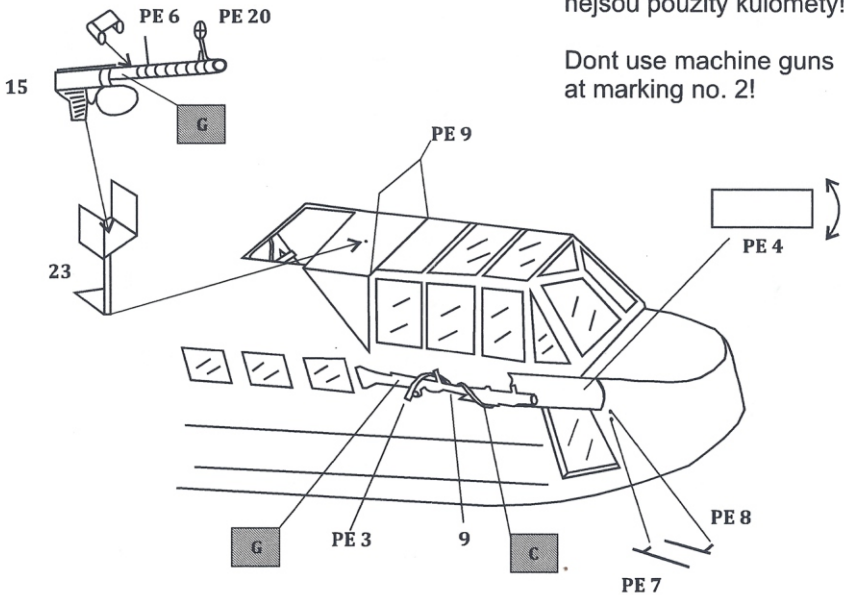

U kamuflážní verze č. 2
nejsou použity kulomety!

Don't use machine guns
at marking no. 2!