

EagleCals
EC#53

□ 1/72

● 1/48

eagle
EDITIONS LTD.

Major Hans "Assi" Hahn
Special Airbrushed Edition Part 4

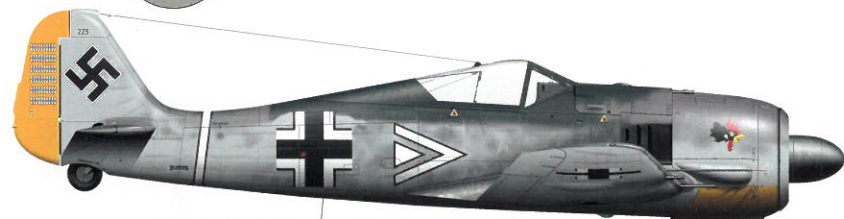
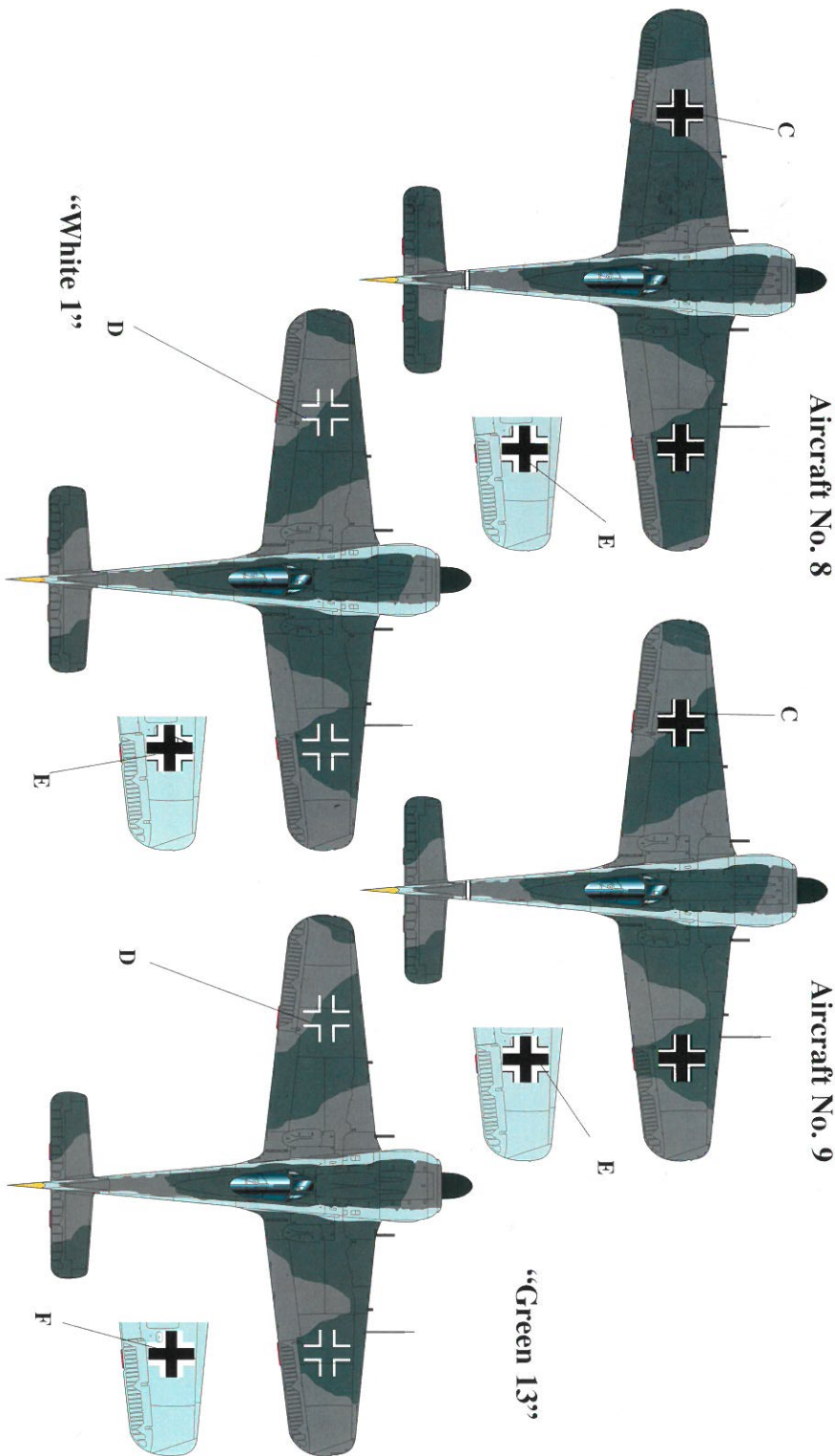

Fw 190 A-2
Assi hahn Aircraft No. 8

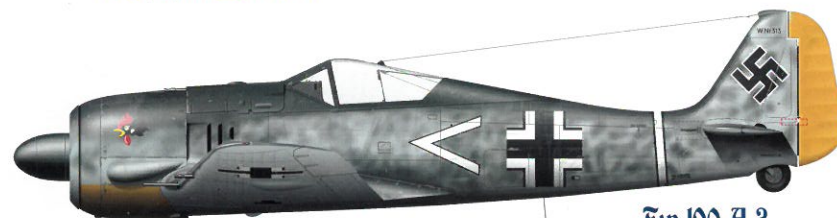

Fw 190 A-3
Assi hahn Aircraft No. 9

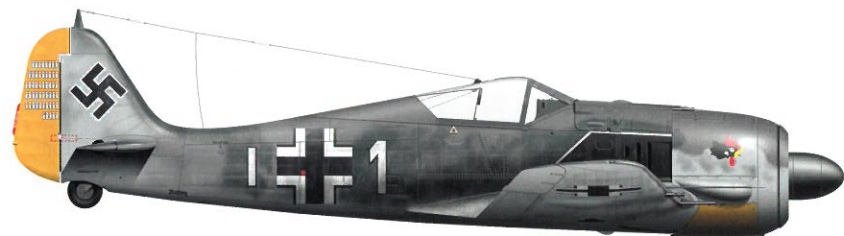

Fw 190 A-4 “White 1”
Obfw. Kurt Knappe 7./JG 2



Fw 190 A-5 “Green 13”
Obst. Walter Oesau Stab JG 2

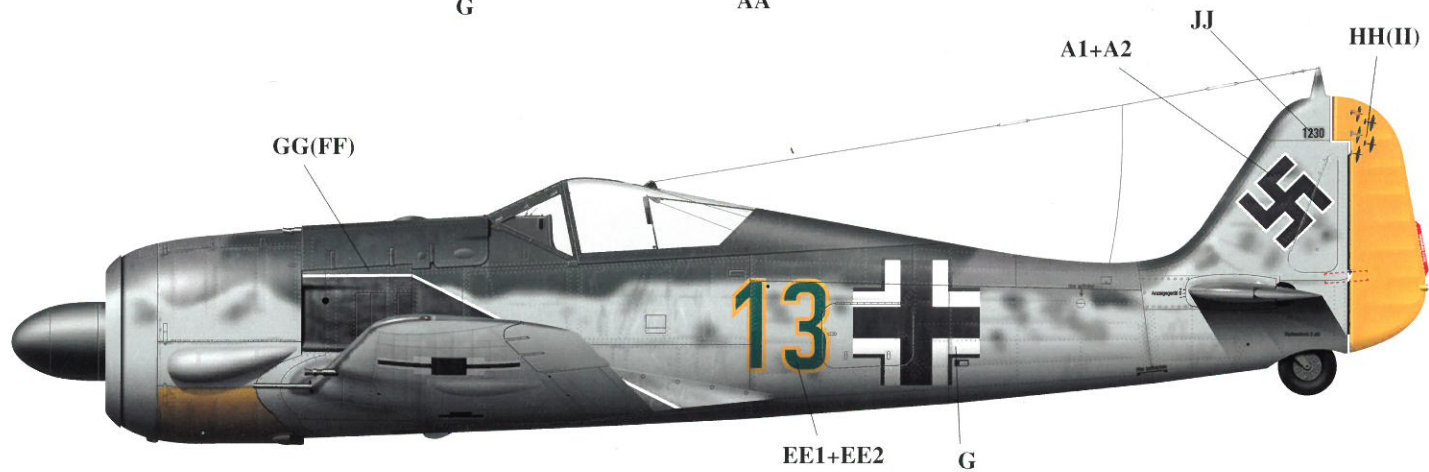
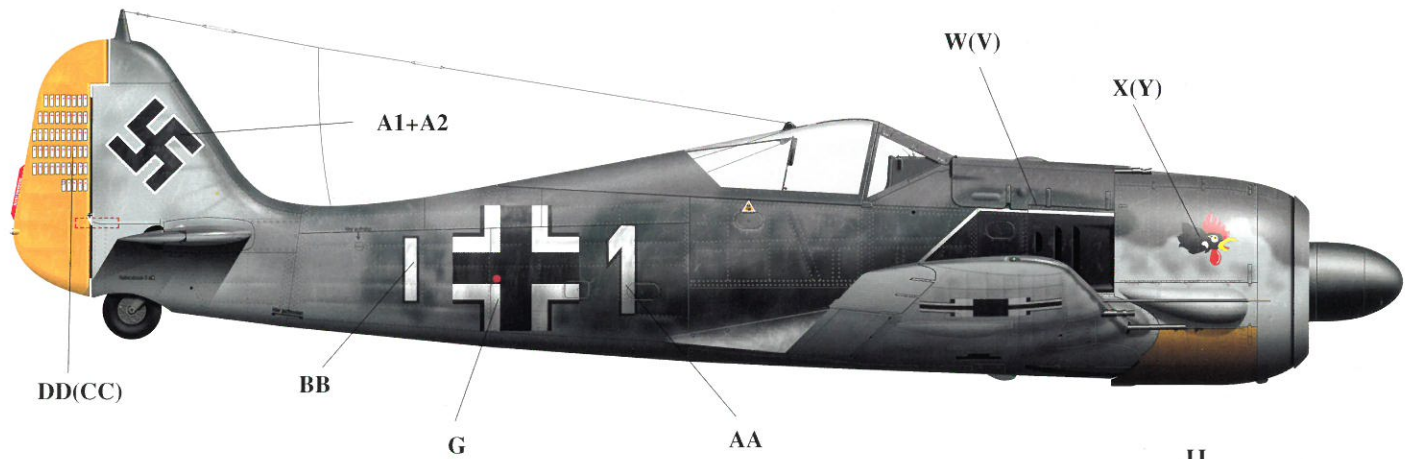
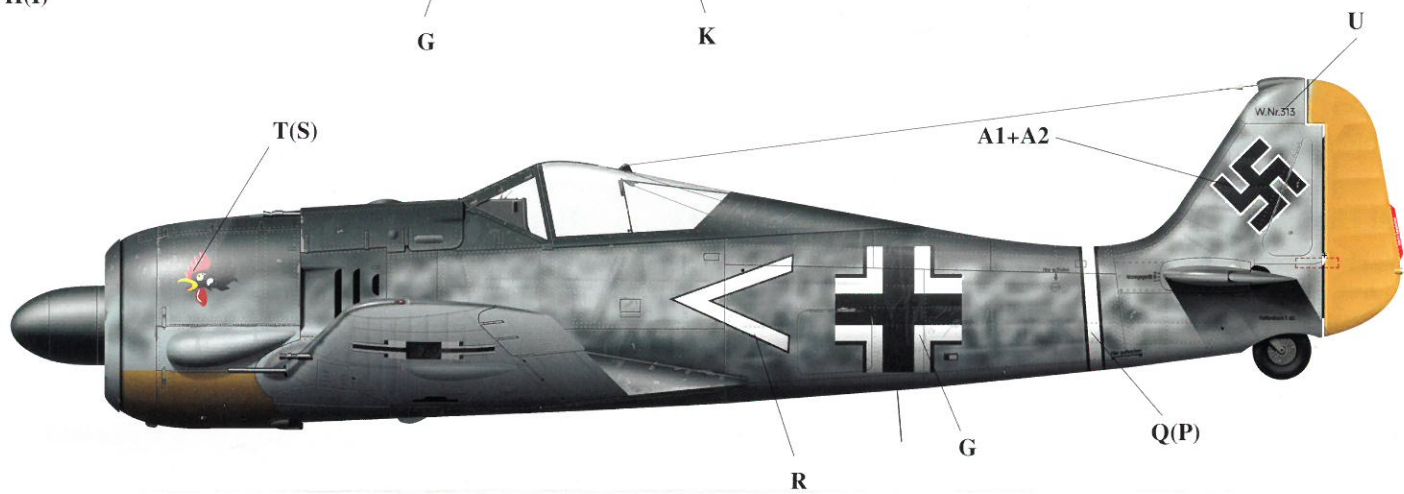
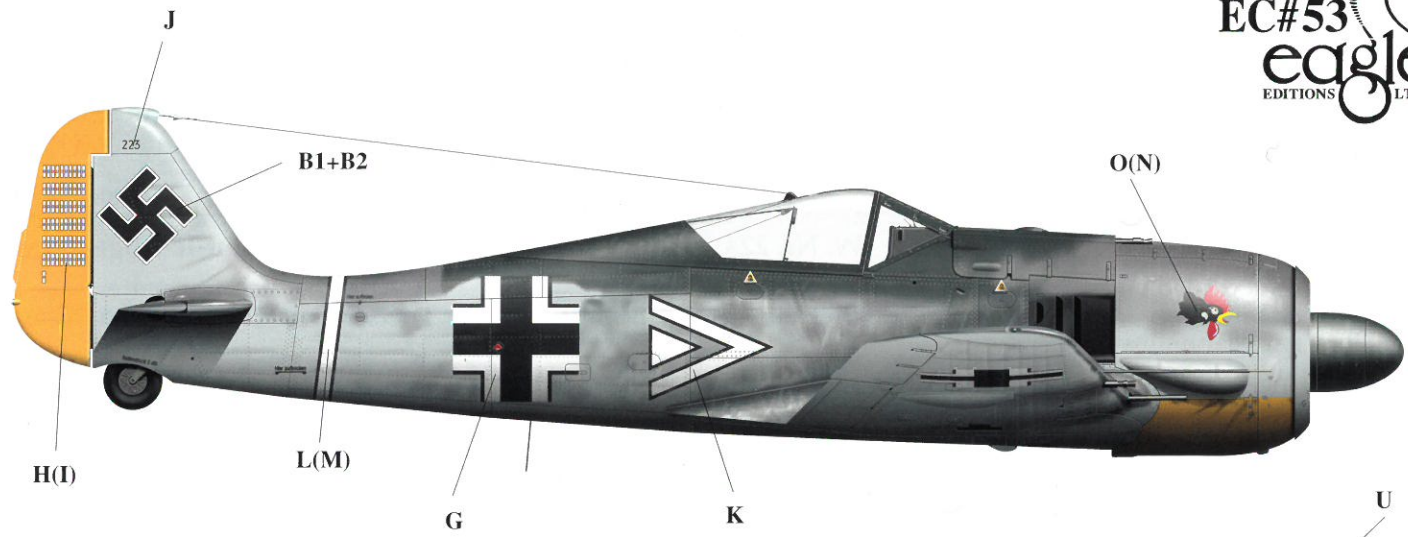

EagleCals #53 Major Hans "Assi" Hahn Part 4 Fw 190 As

This series of aircraft were flown by the colorful and dynamic *Luftwaffe* fighter *Experten*, Assi Hahn and some of his fellow pilots. Refer to the book *Major Hans "Assi" Hahn, the Man and his Machines* by Jerry Crandall available from Eagle Editions for additional information.

Assi Hahn Aircraft No. 8 Fw 190 A-2 W. Nr. 223 III./JG 2 May 1942 Beaumont-le-Roger, France

The 61 victories recorded on the Yellow rudder indicate the date to be after 6 May 1942. Also, the French victories have now been corrected to numbers 3, 4 and 5. Compare this to Hahn's earlier Bf 109 F-4 rudder. FuG 25a antenna mast intact. Note typical small rectangular bump on rear of gun cowl.

COLORS: Undersurfaces, RLM 76 Light Blue or RLM 65 Light Blue; Uppersurfaces, Some sources indicate these early Fw 190s inherited the Bf 109 E camouflage color combination of RLM 02 Gray/RLM 71 Dark Green. Other sources claim the combination of Grays to be RLM 75 Gray-Violet/RLM 74 Gray-Green. RLM 04 Yellow rudder and undercowling. Spinner and prop blades, RLM 70 Black-Green. Streamlined rooster head personal emblem on both sides of engine cowl.

NATIONAL MARKINGS: Fuselage, B2 style 800 mm Black/White crosses with thin Black outline
H2 Black/White *Hakenkreuz* with thin Black outline
Wings: Upper; B2 style 910 mm Black/White crosses with thin Black outline
Lower; B2 style 900 mm Black/White crosses with thin Black outline.

STENCILLING: Factory standard. W. Nr. 223 on both sides of fin.

Assi Hahn Aircraft No. 9 Fw 190 A-3 W. Nr. 5 313 III./JG 2 May/June 1942 Cherbourg, France

Assi Hahn occasionally flew this *Stab* machine. This was the famous aircraft inadvertently delivered to the RAF on 23 June 1942 by Oblt. Armin Faber, *Stab* officer of III. JG 2. Notable features include: FuG 25 a antenna mast intact. Typical small rectangular bump plus a round distinctive bump on rear of gun cowl.

COLORS: Undersurfaces, RLM 76 Light Blue, or RLM 65 Light Blue, uppersurfaces, RLM 75 Gray-Violet/RLM 74 Gray-Green or RLM 02 Gray/ RLM 71 Dark Green. RLM 04 Yellow undercowling and rudder. At the time Faber landed in England, the louvered exhaust panel was painted Black. Color profile illustrated in 74/75/76 combination. Spinner and prop blades, RLM 70 Black-Green. Streamlined rooster head personal emblem on both sides of engine cowl.

NATIONAL MARKINGS: Fuselage; B2 style 800 mm Black/White crosses with thin Black outline
H2a Black/White *Hakenkreuz*
Wings: Upper; B2 style 910 mm Black/White crosses with thin Black outline
Lower; B2 style 900 mm Black/White crosses with thin Black outline

STENCILLING: Factory Standard. W. Nr. 313 on both sides of fin. Actual W. Nr. is 5 313, Arado dropped the first number.

"White 1" Fw 190 A-4 W. Nr. 2413 Obfw. Kurt Knappe 7./JG 2 Early 1943 France

Obfw. Knappe, Knight's Cross recipient after 51 victories in Russia with JG 51. KIA September 1943.

COLORS: Undersurfaces, RLM 76; Uppersurfaces, RLM 75/RLM 74. spinner and prop blades RLM 70. Yellow undercowl and rudder, slightly lighter than undercowl. Black exhaust area trimmed with White.

NATIONAL MARKINGS: Fuselage; B2 style 800 mm Black/White crosses with thin black outline
H2a Black/White *Hakenkreuz*
Wings: Upper; B6 style 910 mm White outline crosses;
Lower; B2 style 900 mm Black/White crosses with thin Black outline

STENCILLING: Standard. 51 victory bars on both sides of rudder.

"Green 13" Fw 190 A-5 W. Nr. 1230 Obslt. Walter Oesau Stab JG 2 June 1943 Beaumont-le-Roger, France

Walter Oesau achieved 123 victories, was *Kommodore* of JG 2 until June 1943. KIA 11 May 1944 as *Kommodore* of JG 1. FuG 25a antenna.

COLORS: Undersurfaces, RLM 76; Uppersurfaces RLM 75/RLM 74. Spinner and prop blades RLM 70 Black-Green. Yellow undercowl and rudder. Black exhaust area trimmed in White.

NATIONAL MARKINGS: Fuselage; B2 style 800 mm Black/White crosses with Black outline
H2a Black/White *Hakenkreuz*
Wings: Upper; B6 style 910 mm White outline crosses;
Lower; B3 style 900 mm Black/White crosses

STENCILLING: Standard. Photo shows drawings of five bombers on fin, representing victories 101-105, two of which are on fire, port side only.

© 2003 Eagle Editions Ltd. All images/photos copyrighted by Eagle Editions Ltd.

No copies may be reproduced without written consent from publisher Eagle Editions Ltd. P.O. Box 580 Hamilton MT 59840

The color schemes depicted are the artist's interpretations of the available photographic references only. The final decision resides with the modeler.

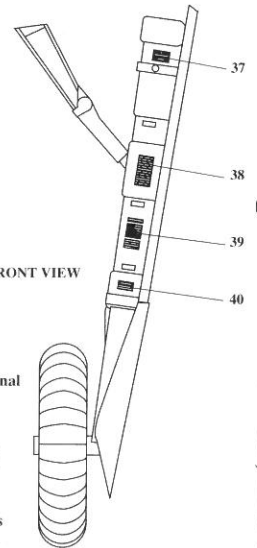
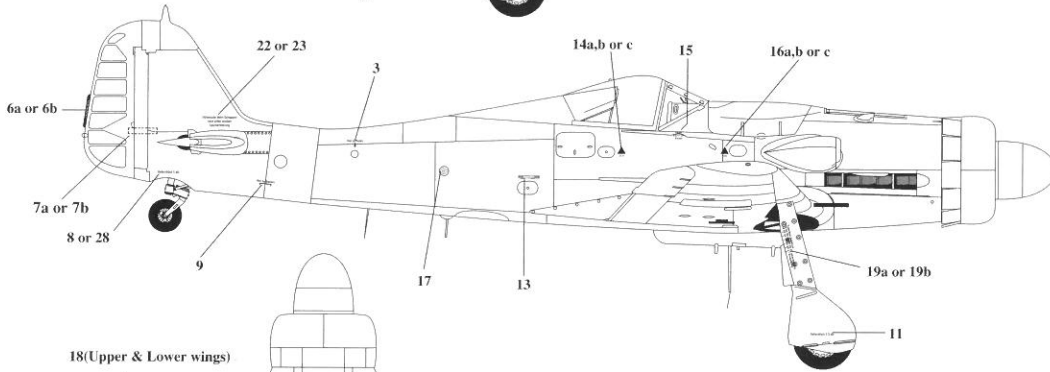
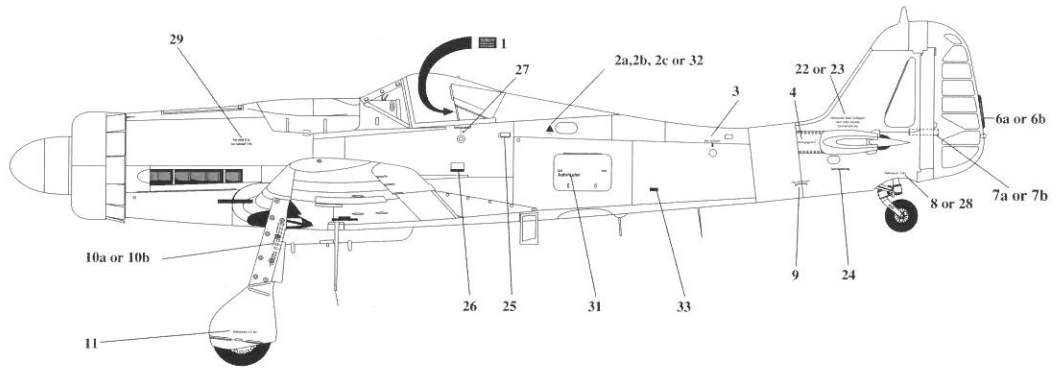

FRONT VIEW

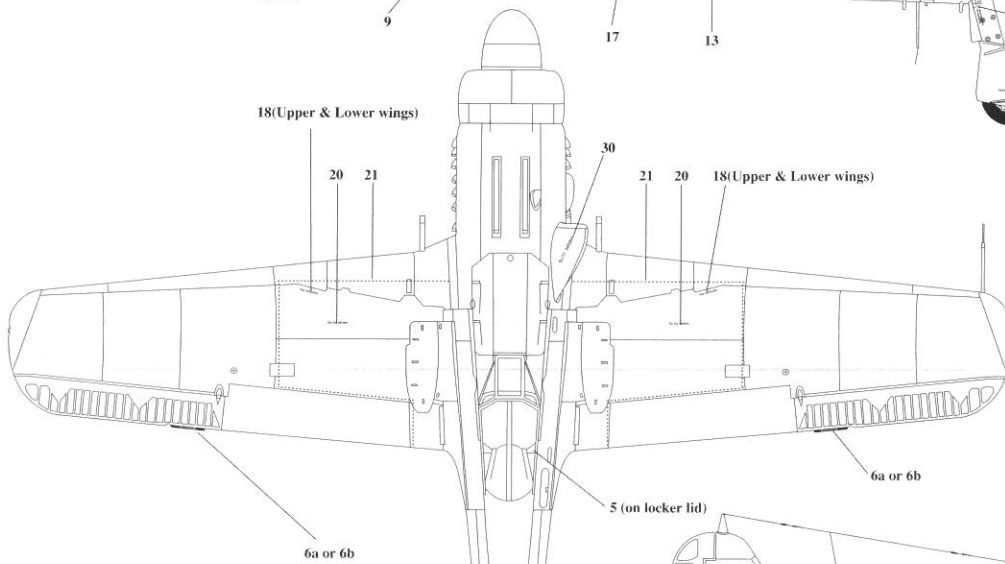

Propeller drawings are provisional
 not to scale

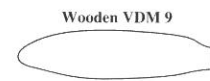

Wooden VDM 9

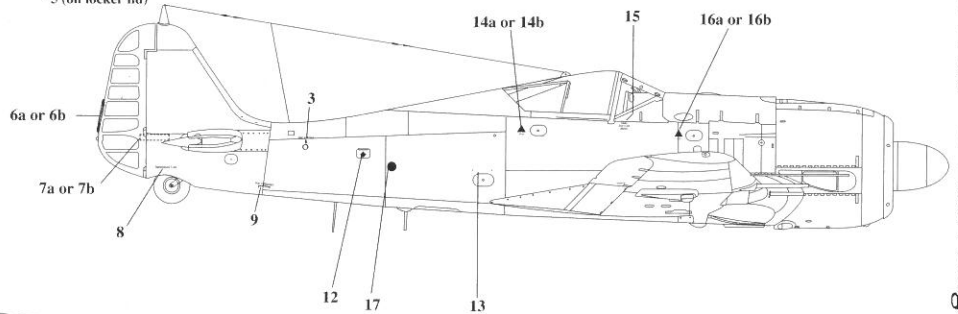

- Fw 190A-1 thru A-4 use 41
- Fw 190A-7 thru A-8 with EXTERNAL WEIGHTS use 42
- Fw 190A-5 thru A-9 use 43



REAR VIEW

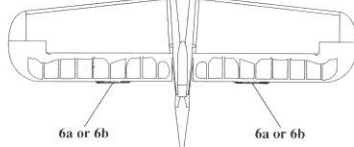

44 (bottom center of front cowl ring)

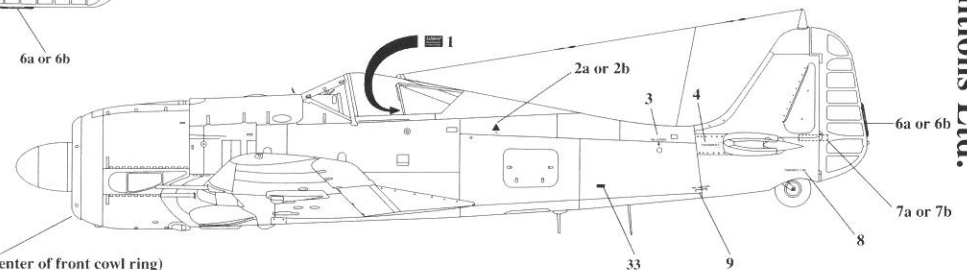

Stencils no. 22 thru 32 not used on Fw 190A aircraft.

NOTE: Stencil diagram drawings are representational only. Check your references for the specific details and differences between variants.



223 225

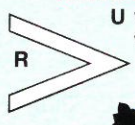
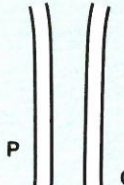
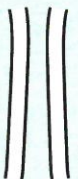

U W Nr. 313
W Nr. 313



V

13
13

EE1



DD



CC BB



AA

W



X

13
13

EE2



II

1230 1230

JJ



HH

GG

FF



F



G



E

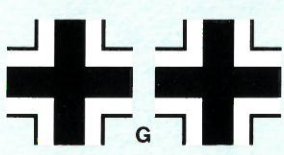

G

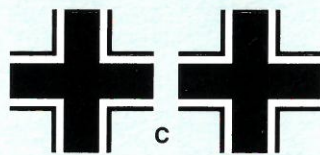

C

1	2a	2b	2c	3	4	5	6a	9	10a	10b	11b											
12	13	14a	14b	14c	15	16a	16b	16c	21	17	18	19a	19b	20								
22	23	24	25	26	27	28	29	30	31	32	33	34	35	36	37	38	39	40	41	42	43	44



A1



B1