

ACADEMY

HOBBY MODEL KITS

ISRAELI AIR FORCE MIRAGE IIIC 1/48 scale

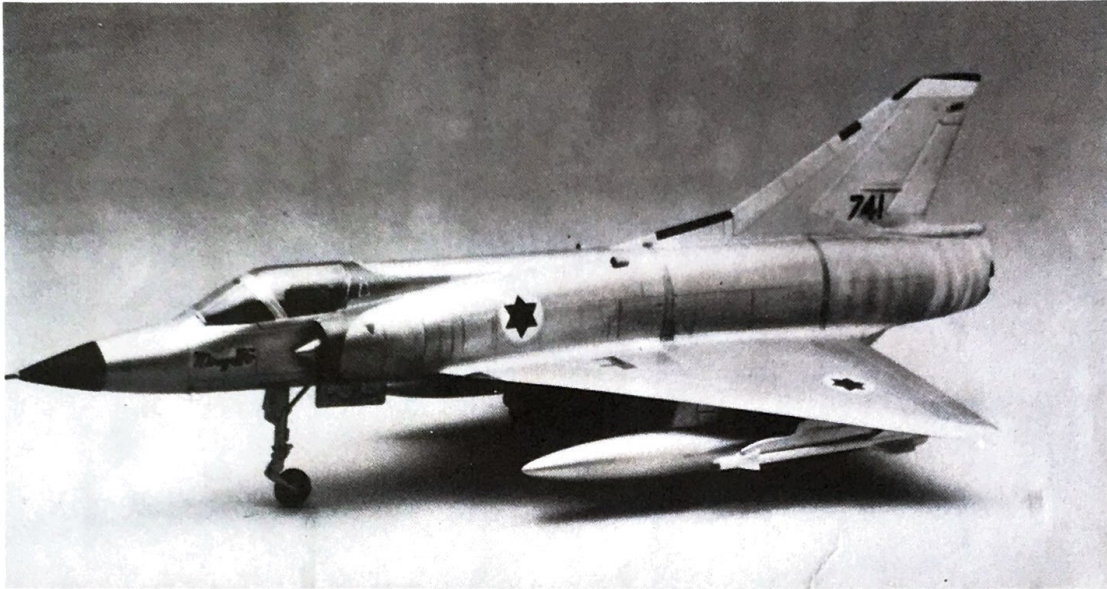

The delta-winged Dassault Mirage III can be found in many air forces throughout the world. This popular French fighter was first flown in 1956 and became operational with the French *Armee de l'Air* in the early '60's. The Mirage's first combat experience came during the Middle East war of 1967, where the Israeli pilots demonstrated their superb flying skill in maneuvering the Mirages to a high-scoring victory.

The proven combat ability of the Mirage quickly led to foreign sales and the French fighter soon found itself in the markings of ten countries.

As popular as it is from a commercial point

of view, the Mirage does suffer from some rather severe limitations. The design was developed during an era when the highest speed attainable was the main objective, to the detriment of maneuverability. The Mirage IIIC is fast, but it requires a rather long runway, especially if a heavy weapons load is aboard. In a tight turn the delta wing causes the speed to drop severely, but an experienced pilot can use this to his advantage and force his enemy to overshoot.

The Mirage IIIC is powered by an afterburning SNECMA Atar 9 engine giving a maximum thrust of 13,225 lbs and a top speed of 1,460 mph at 39,375 feet.

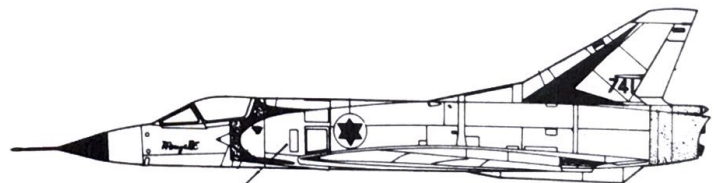
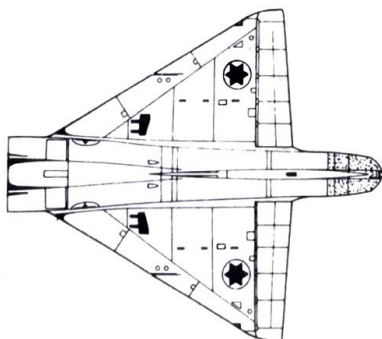
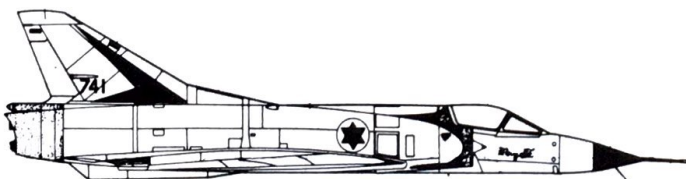

NATURAL METAL
BLACK NOSE & ANTENNA

ACADEMY
HOBBY MODEL KITS

ACADEMY
ACADEMY PLASTIC MODEL CO., LTD.
521-1, Yonghyeon-dong, Uijeongbu-si, Gyeonggi-do, Korea
090-969-7000

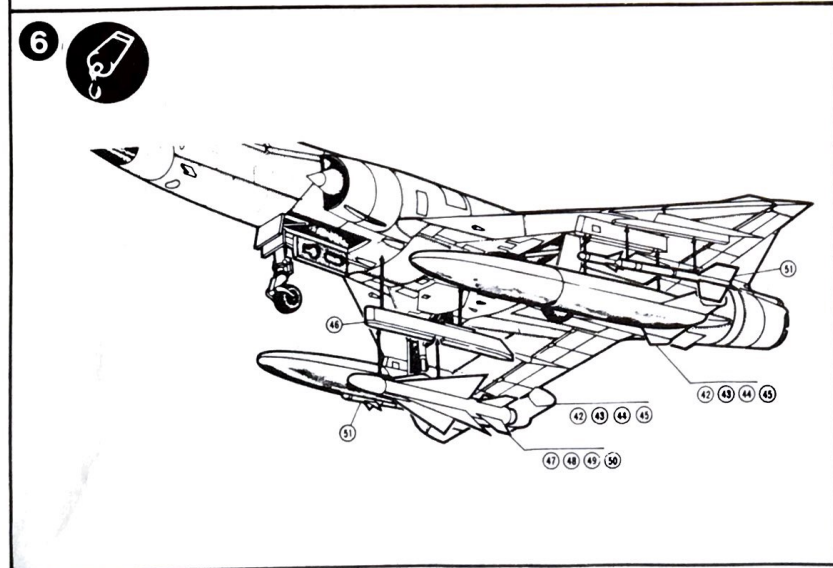
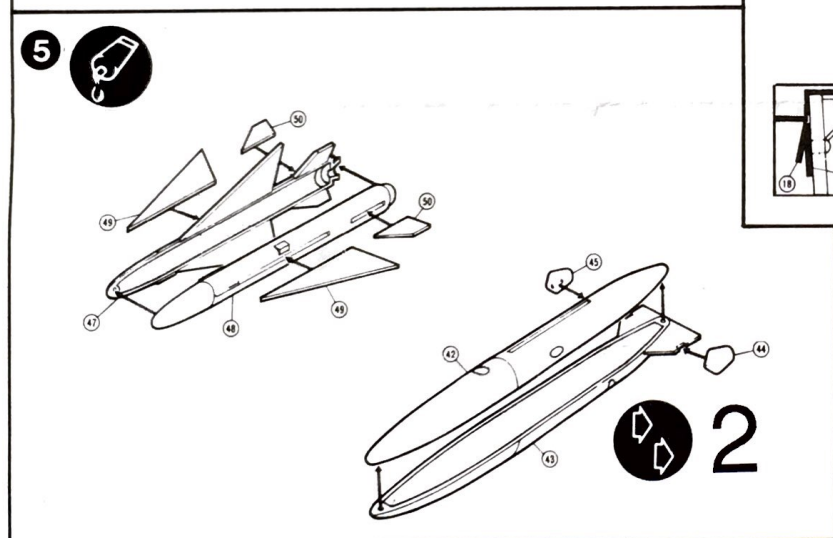
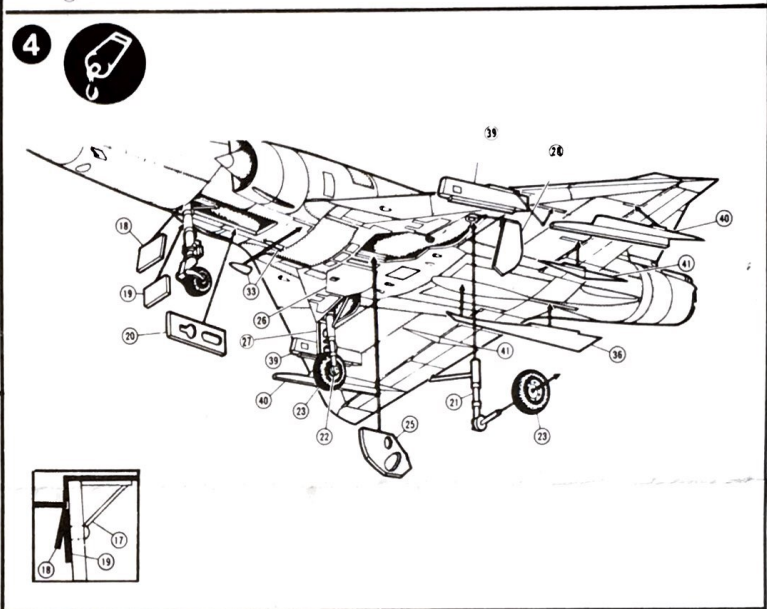
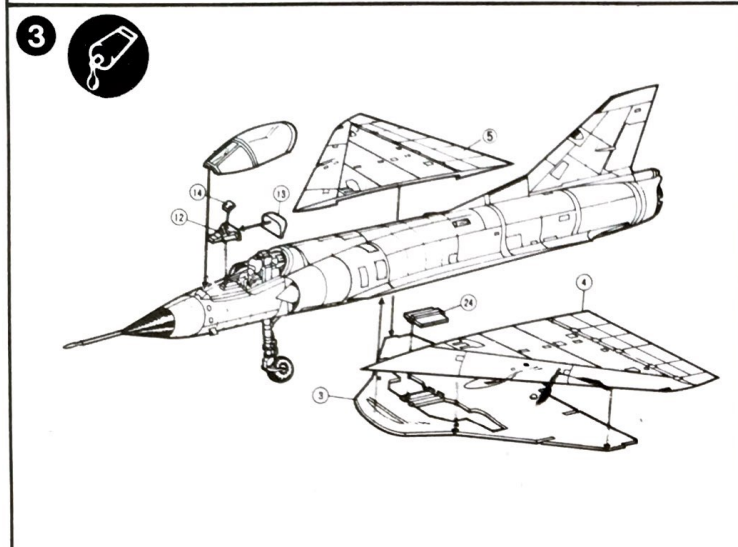
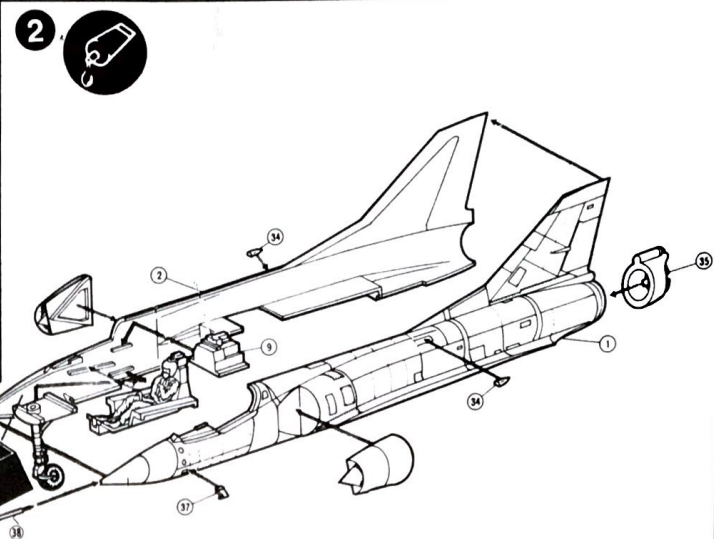
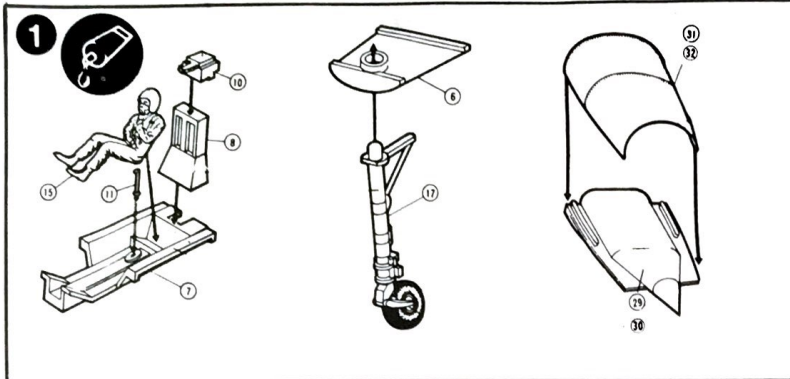

Cement Parts
Coller
Kleben
Pegar
Incollare
Colar
Kleven



DO NOT cement
Ne pas coller
Nicht kleben
No pegar
Non incollare
Não colar
Niet kleven



Cut away
Couper
Scheiden
Cortar
Tagliare
Cortar
Snijden



Optional parts
Choix
Auswahlmöglichkeit
Eleccion
Scelta
Opcao
Keuze



Repeat operation
Répéter l'opération
Vorgang wiederholen
Repitir la operacion
Ripetere
Repitir a operação
Herhalen