

**AZmodel**  
Plastic kits

# Supermarine Spitfire

## MK I/II

Spitfire Mk I Early    Spitfire Mk II a  
Spitfire Mk I Late    Spitfire Mk II LR  
Spitfire Mk I G

Plastic model    AZ 7287    AZ 7288    AZ 7289    AZ 7290    AZ 7295    scale :1/72

The Supermarine Spitfire was the only of the to fight in front line service, from the beginnings of the conflict, in September 1939, through to the end in August 1945. In 1936, before the first flight of the prototype, the placed an order for 310 Spitfires. The early Mk Is were powered by the 1,030 hp (768 kW) engine driving an Aero-Products "Watts" 10 ft 8 in (3.3 m) diameter two-blade wooden fixed-pitch propeller, weighing 83 lb (38 kg).

In the summer of 1939 an early Mk I K9788 was fitted with a new version of the Merlin, the XII. This engine included a , instead of the electric system of earlier and some later versions of the Merlin, and it required a small "teardrop" blister on the forward starboard cowling. A small number of Mk IIs were converted to "Long Range" Spitfires in early 1941. These could be recognised by the fixed 40 gal (182 l) fuel tank which was fitted under the port wing. With a full tank manoeuvrability was reduced, maximum speed was 26 mph (42 km/h) lower and the climb rate and service ceiling were also reduced. Several squadrons used this version to provide long-range bomber escort.

The producer express a sincere word of thanks to Mr Robert Humphreys of SAMI, for his help provided during the preparation of this kit. This model kit was prepared using the plans drawn by Mr A. Granger, M.I.S.T.C., in 1977.

### Plastic parts

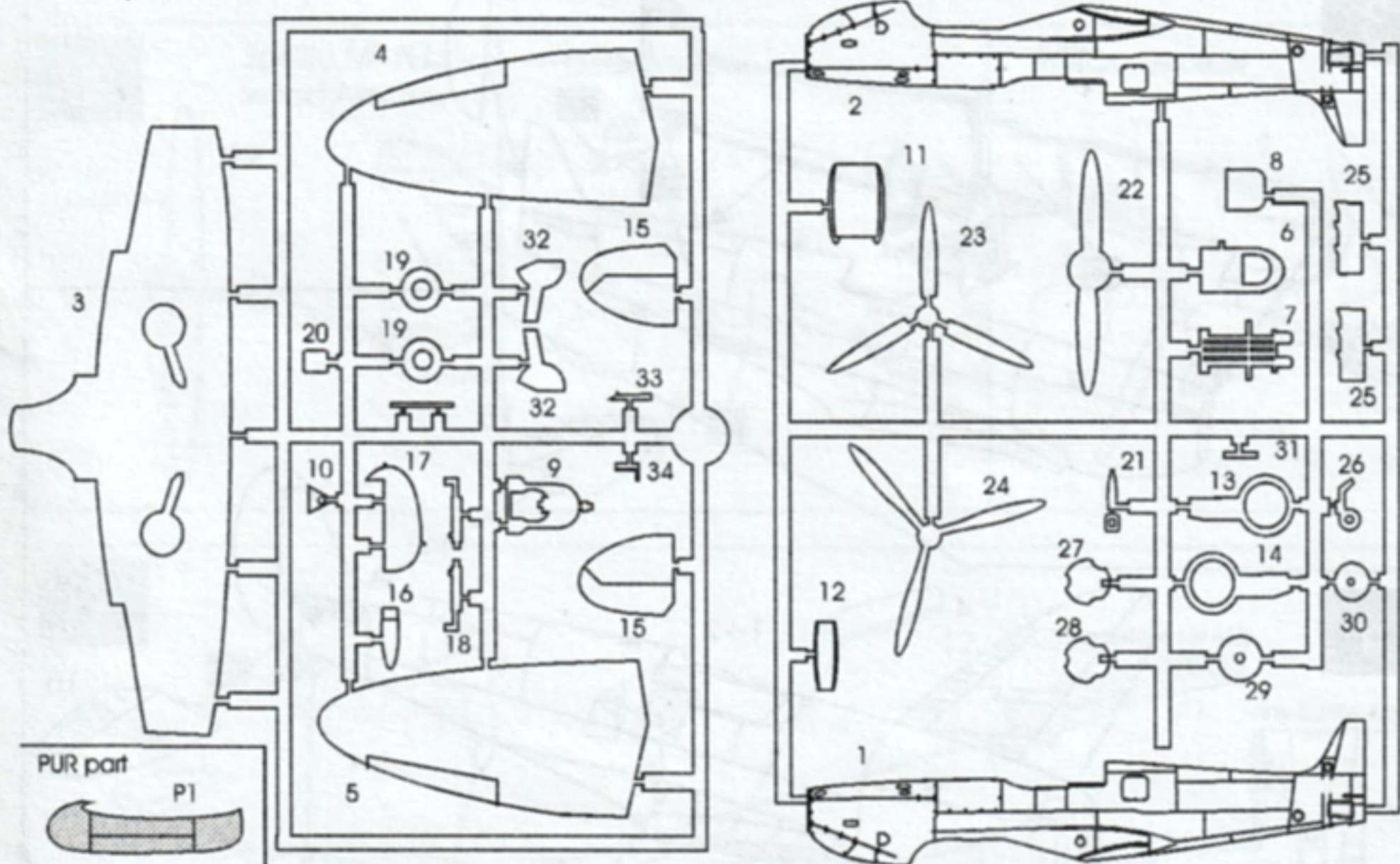

PUR part

P1

Transparent parts

T1 only Spitfire I Early



T2 Spitfire II



Decals

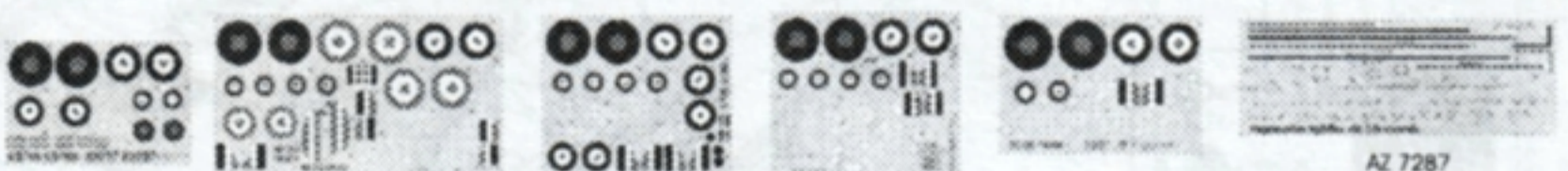

AZ 7287

AZ 7295

AZ 7289

AZ 7288

AZ 7290

AZ 7287  
AZ 7288  
AZ 7289  
AZ 7290  
AZ 7295



OPTIONAL

VOLBA



BEND

OHNOUT



OPEN HOLE

VYVRTAT OTVOR



SYMETRICAL ASSEMBLY

SYMETRICKÁ MONTÁŽ



A NOTH

ŽÁREZ



REMOVE

ODŘÍZNOUT



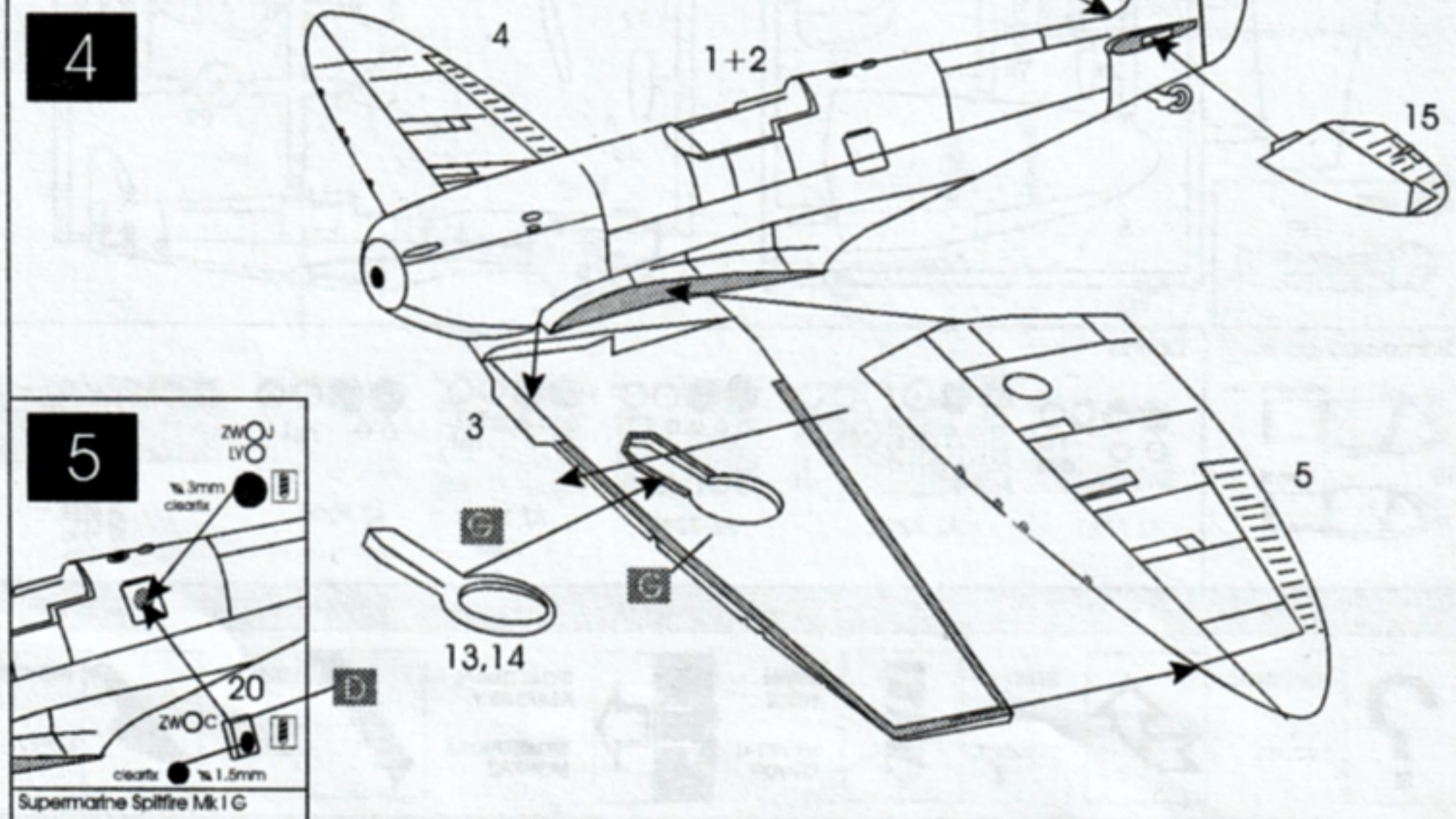
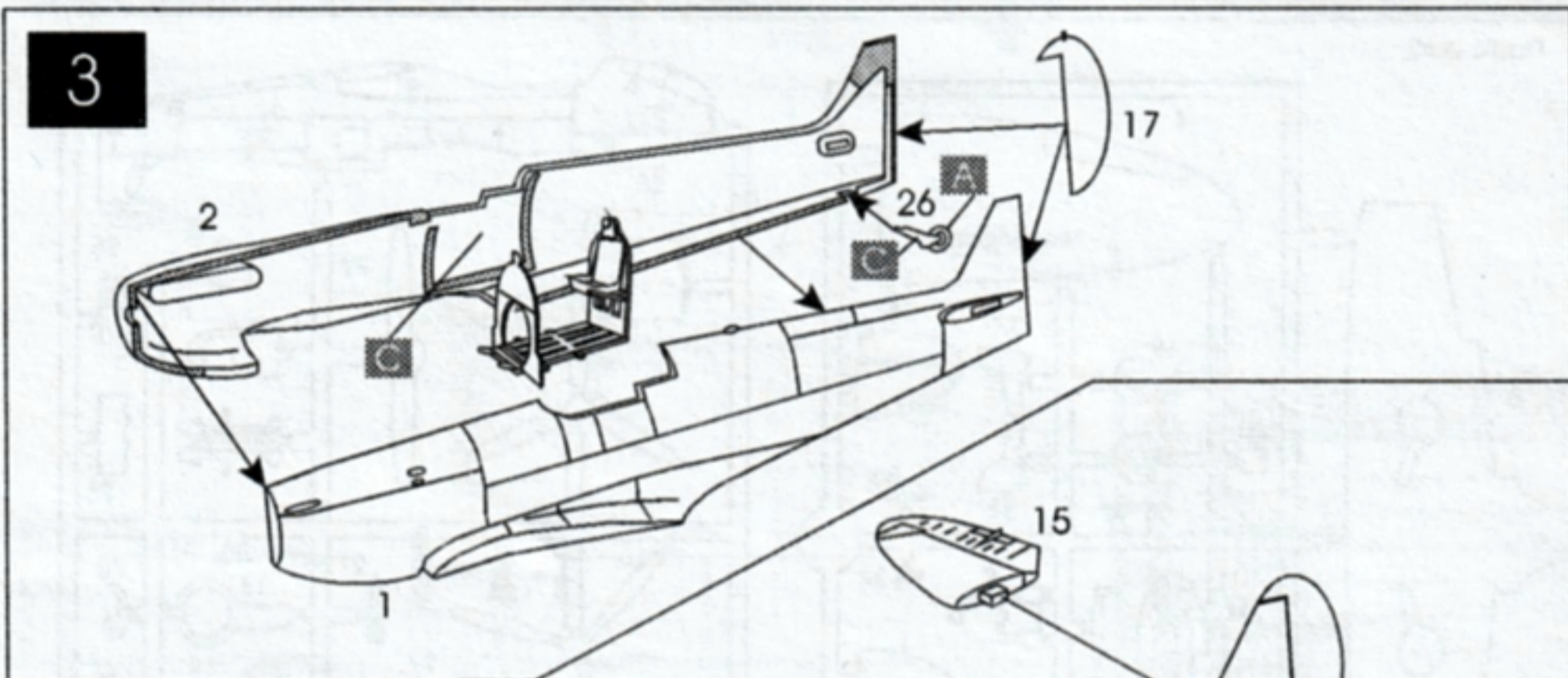
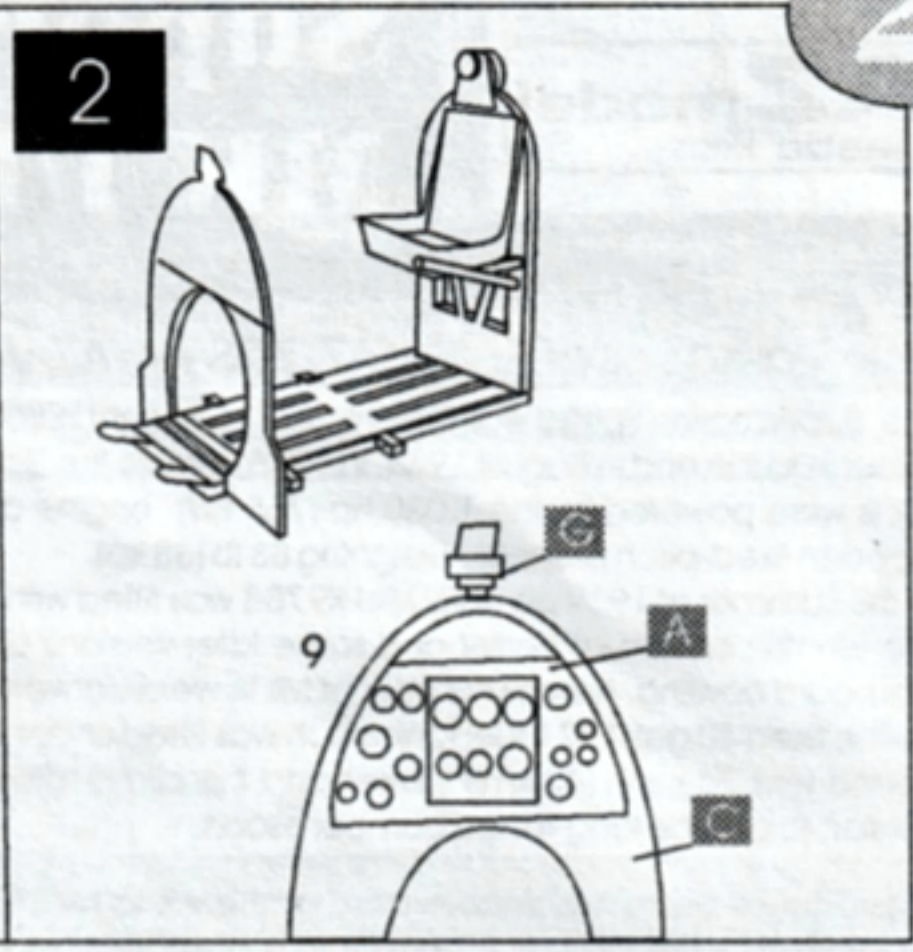
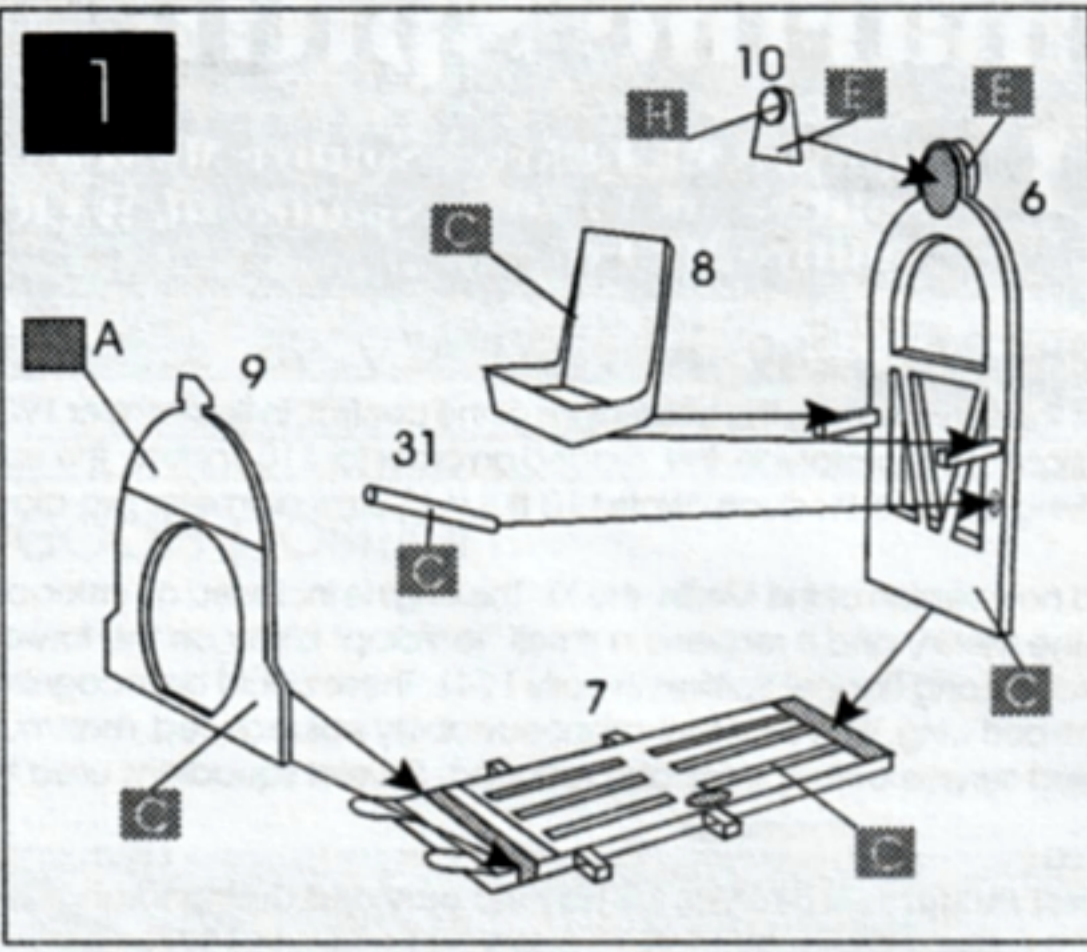



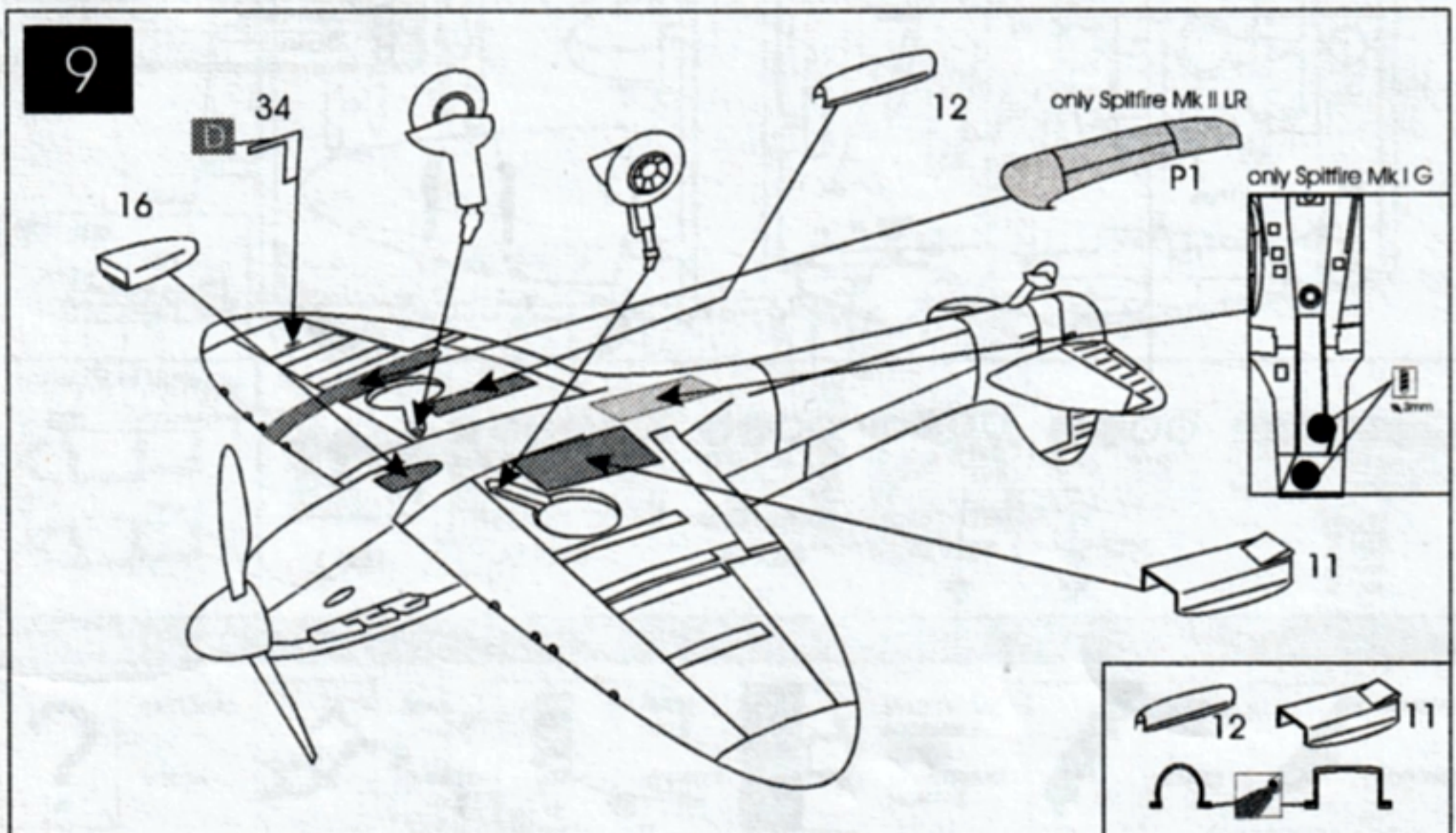
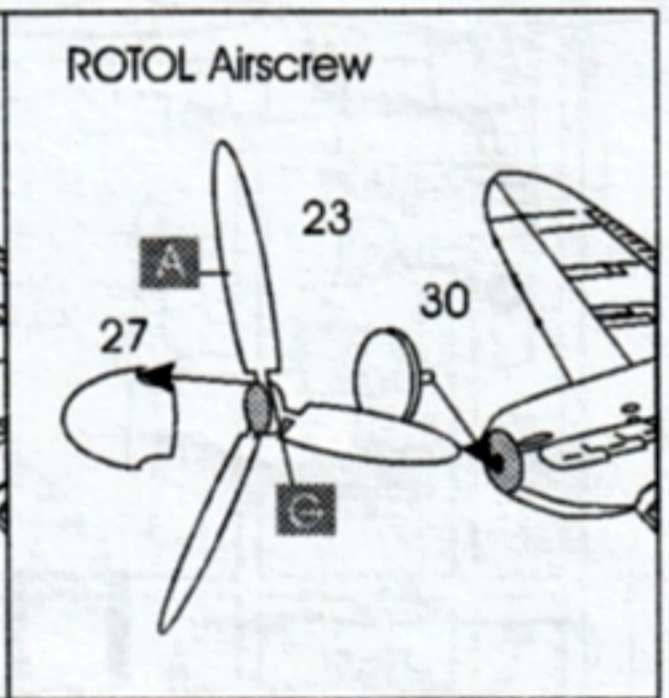
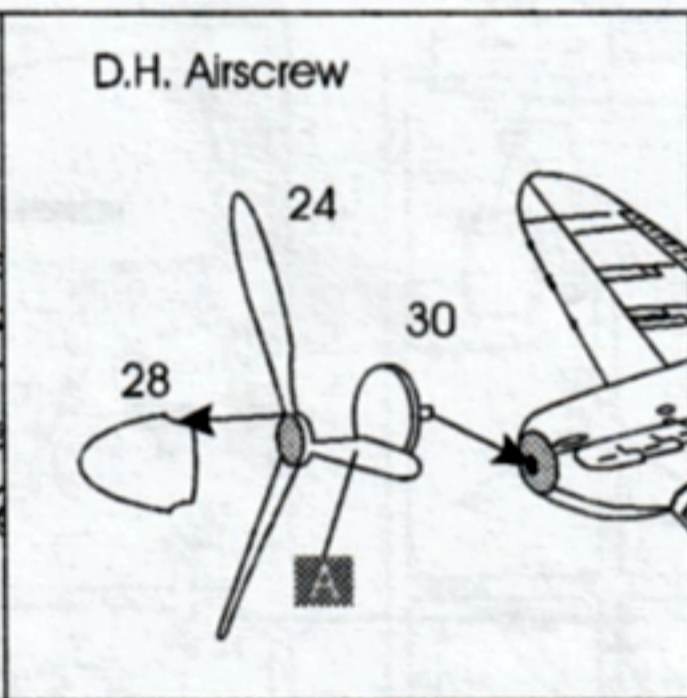
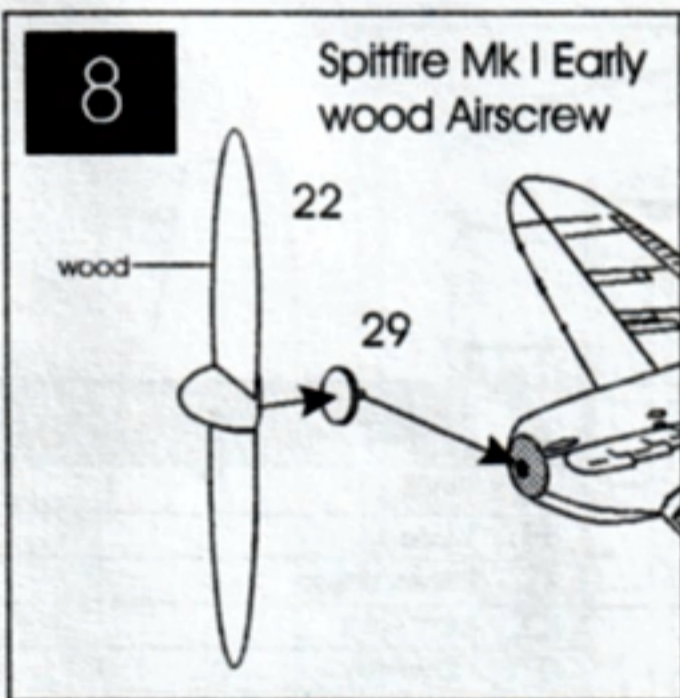
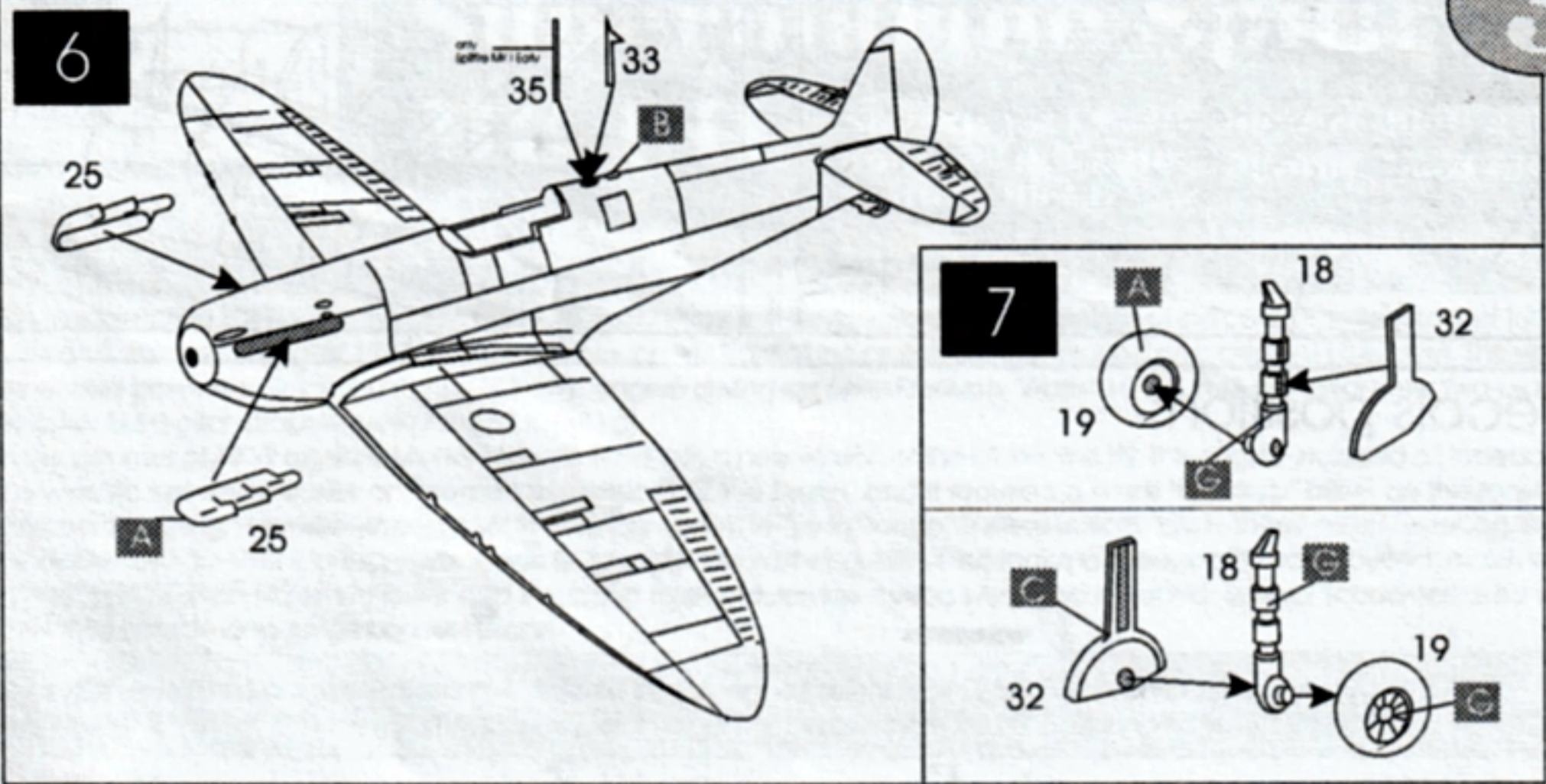





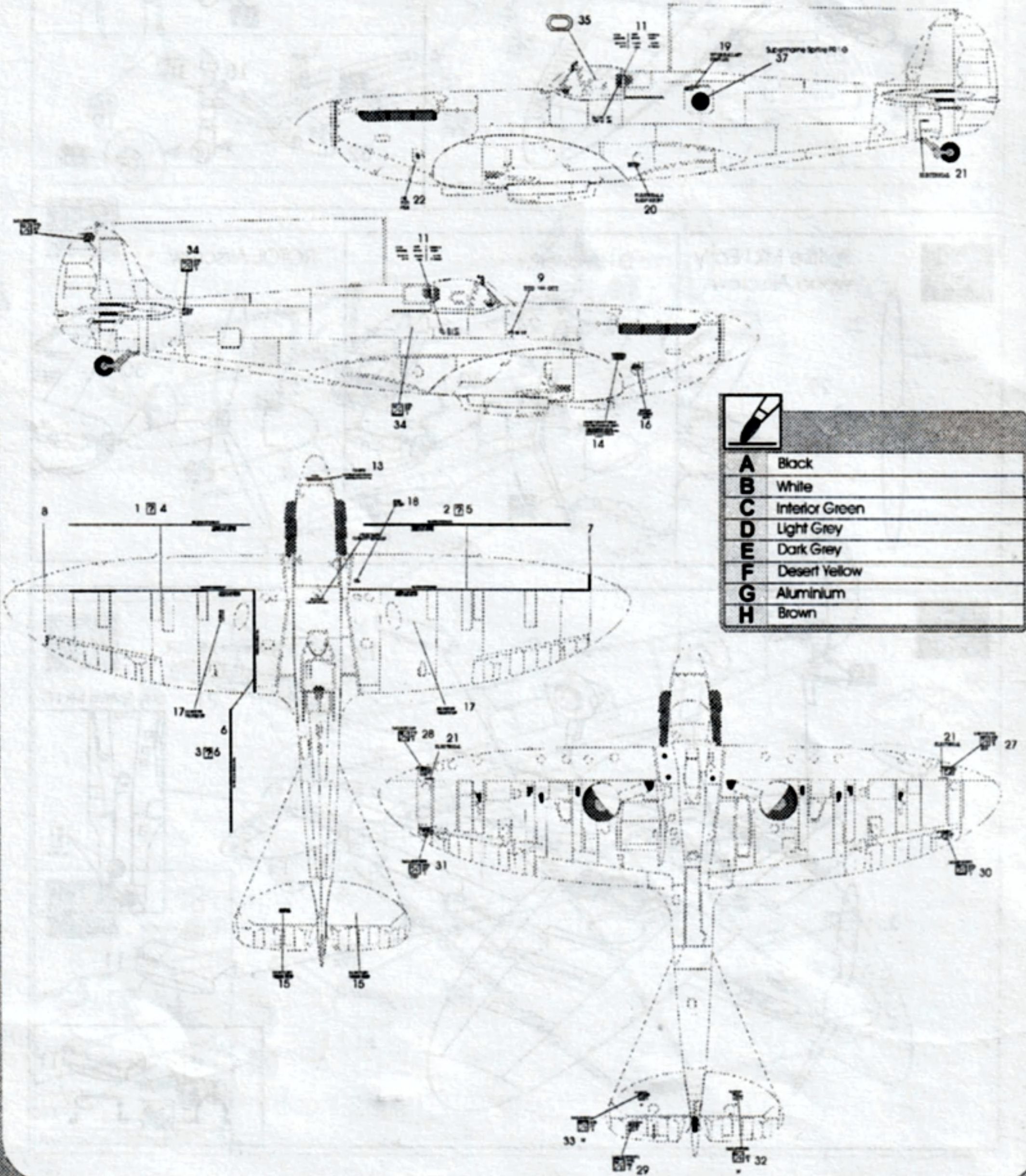

Decals position:



	<b>A</b> Black
	<b>B</b> White
	<b>C</b> Interior Green
	<b>D</b> Light Grey
	<b>E</b> Dark Grey
	<b>F</b> Desert Yellow
	<b>G</b> Aluminium
	<b>H</b> Brown



# Supermarine „Spitfire” Mk.I „Late”

1

Supermarine Spitfire Mk I , AR 212 ,LV-N ,57 OTU squadron, Hawarden 16.3.1942

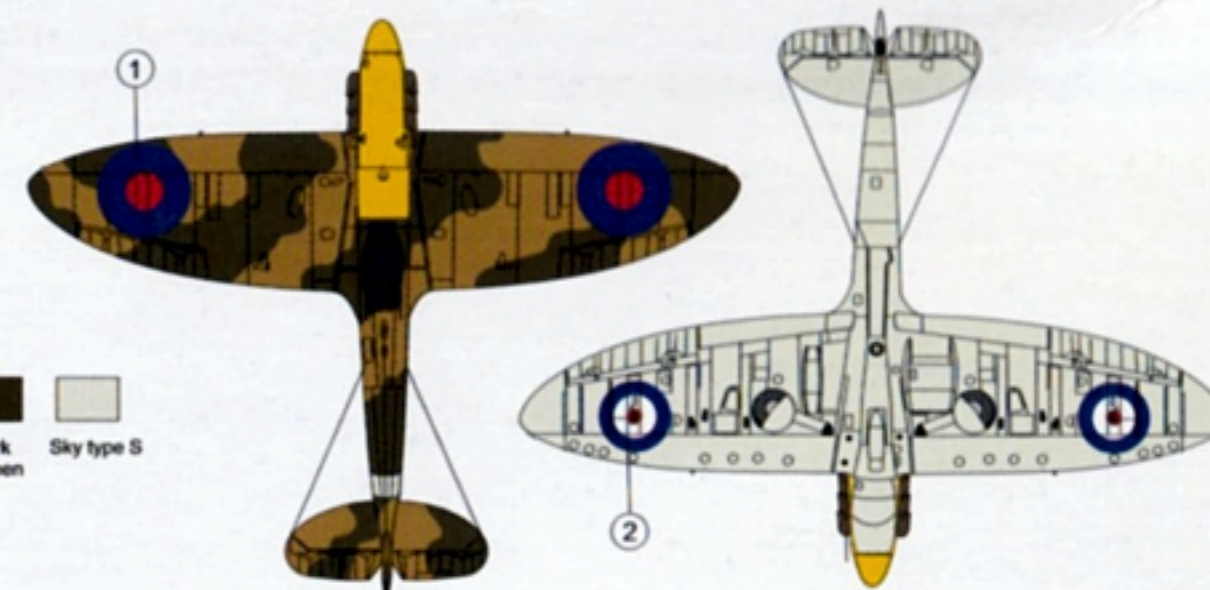
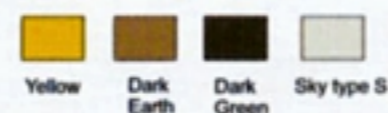
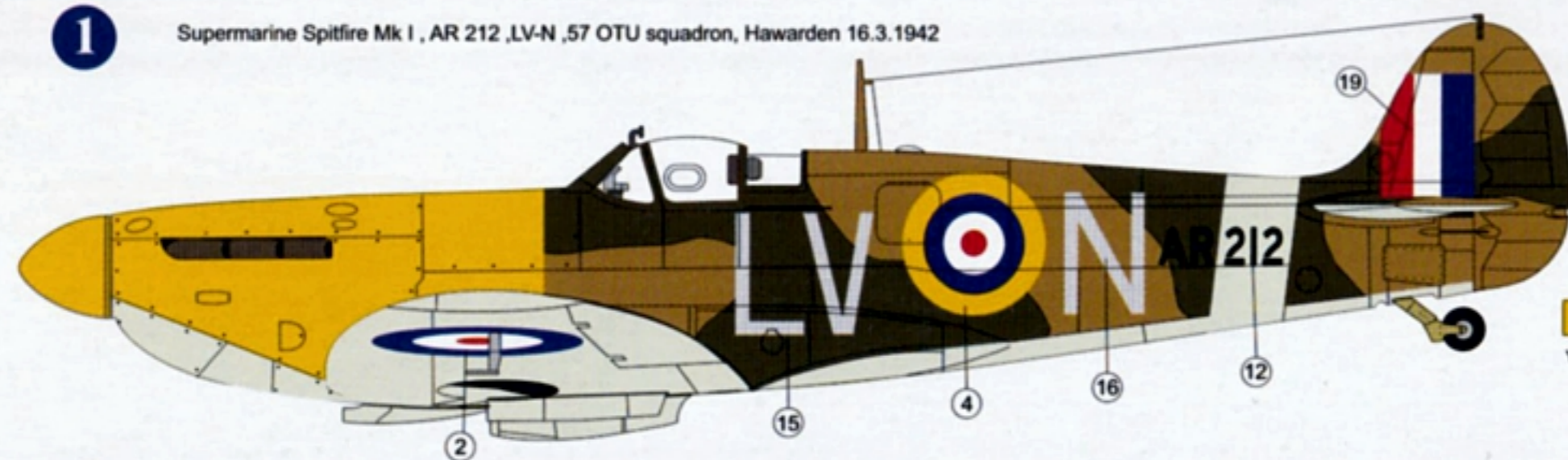

2

Supermarine Spitfire Mk I, HK 854,1 Middle East Training School ,airport El Ballah ,Egypt 1942

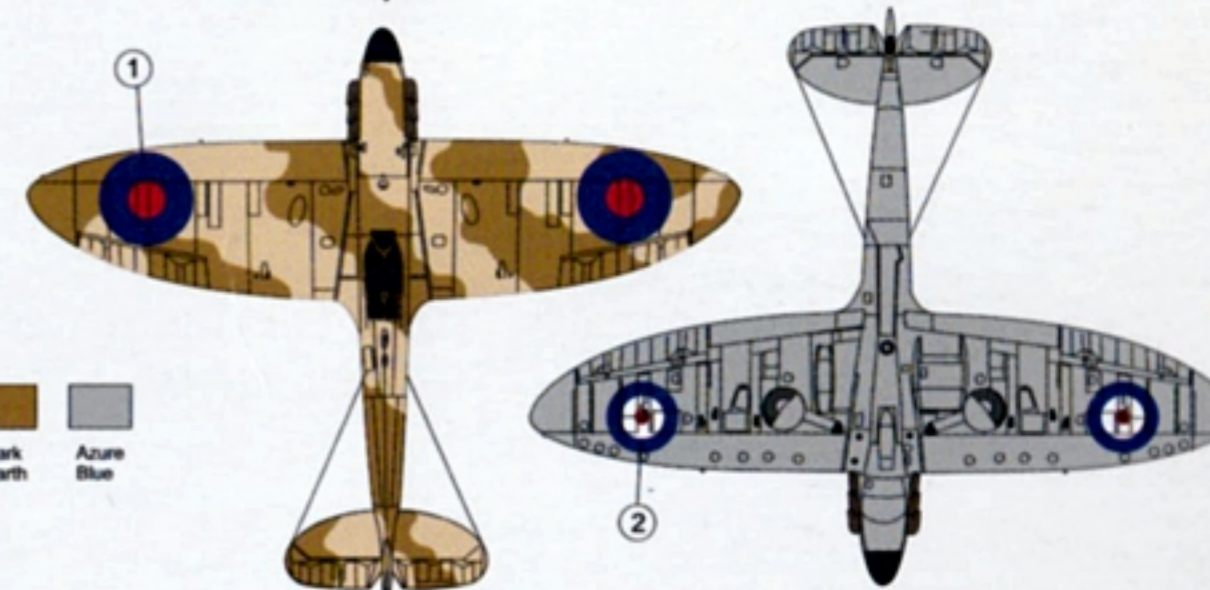

3

Supermarine Spitfire Mk I , 01 , FWB  
He spitfire delivered it the France, of the day 18.6.1940 phellem it the airport Orleans-Briecy  
it the germane arm.

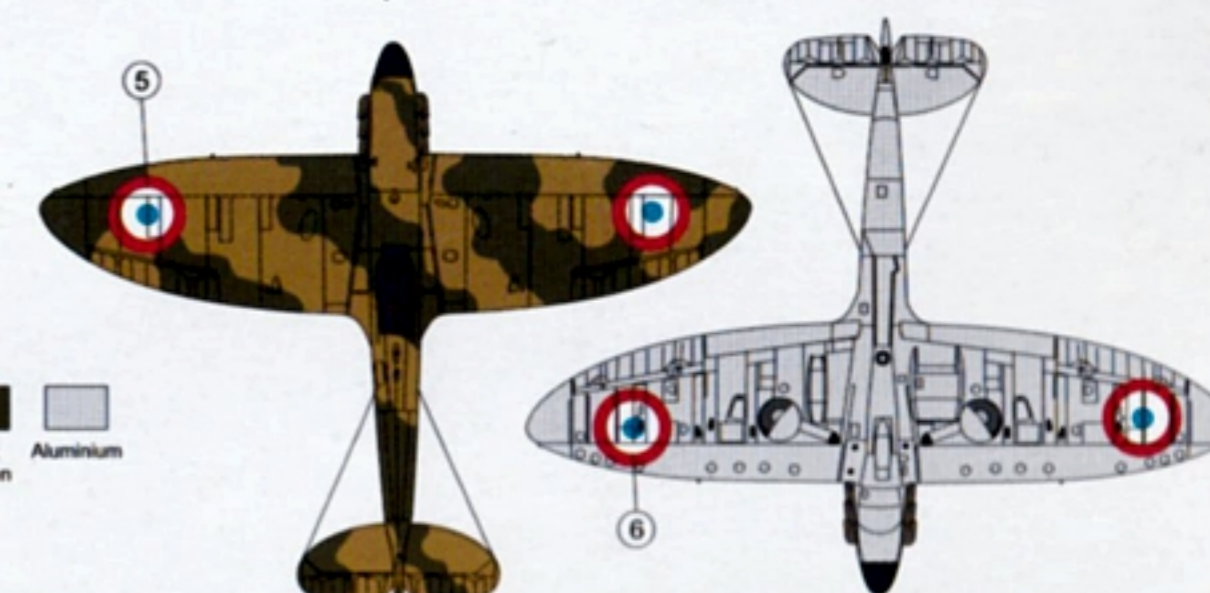
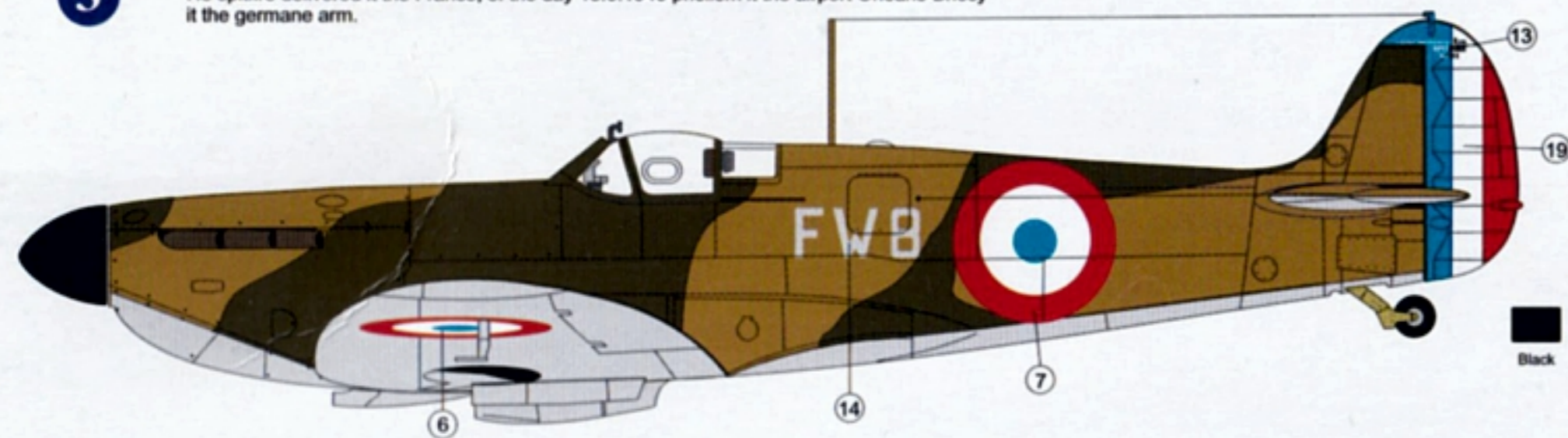

4

Supermarine Spitfire Mk I , X4031 ,RY-H ,313.czech squadron,from June would August 1941.  
Pilot F/Lt. Karel Mrazek

