

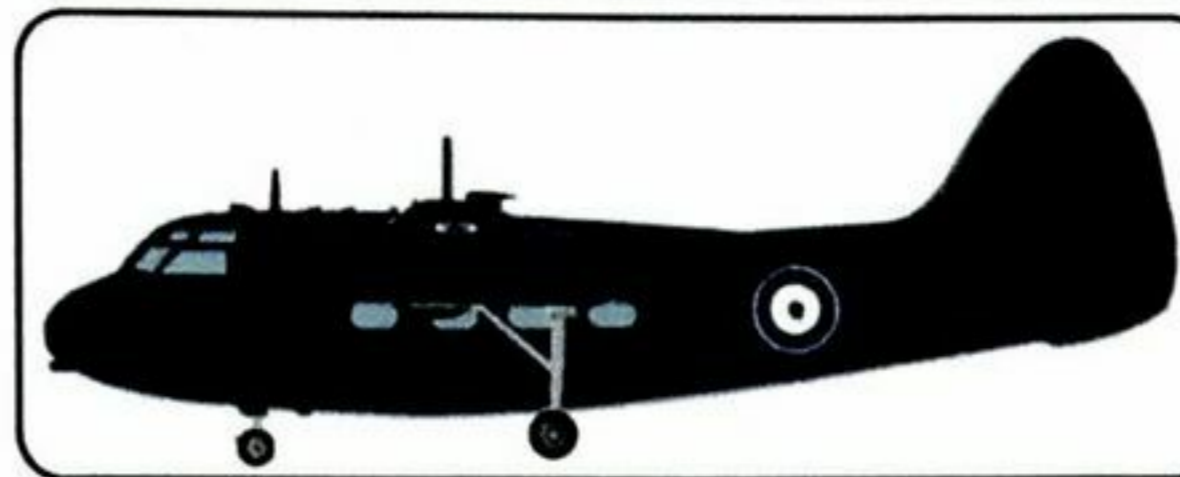

72157 Percival P.50 Sea Prince 172



	Humbrol	Agama	Model Master	Gunze Sangyo	FS 592b
A stříbrná Silver	11	08Me	1546	H8	17178
B hliník Aluminium	56	46Me	1781	H339	17178
C černá Black	33	07	1749	H12	37038
D bílá White	34	121	1768	H11	37875
E barva pneumatik Tyre	182	36	1592	H77	35030
F interierová zelená Interior Green	78	B10	2062	H58	34151
G výfuky Exhaust Tubs	113	54	106	H344	30111
H motorová šedá Engine Gray	128	A46	1715	H339	26031
J světlá šedá Light Gray	129	A31	1730	H325	26440
K zinchromatová Zinkchromat	63	A11	1735	H346	33275
L letadlová modrá Air Blue	65	N5	2078	H41	35114
M modrá Blue	190	34	1772	H90	15050
N signální červená Signal Red	174	17	1705	H90	11310
O signální zelená Signal Green	208	19	1524	H94	13591
P signální žlutá Signal Yellow	69	15	2717	H91	13591

Percival P.50 Sea Prince C1 (Royal Navy)



obtisk
Decals

Stručná historie Percival Prince

Vývoj letounu Percival Prince byl zahájen v těsně poválečném období. Vycházel z předchůdce Percival Meganser, kterému byl dost podoben, jen byl mnohem těžší a větší. Jednalo se o lehký dvoumotorový hornokřídý transportní letoun se zatahovacím třikolovým podvozkem. Dva motory každý o výkonu 520 hp byly instalovány od firmy Alvis Leonides s označením 501/4, později 502/4.

Prototyp P.50 Prince poprvé vzlétl 13. května 1948 v Lutonu. První tři letouny Sea Prince C1 vstoupily do služby v únoru 1953 a sloužily u Royal Navy. Během několika let firma Percival upravila letouny pro produkci dalších 6 verzí. Sea Prince C1 byl následován cvičnou verzí s označením Percival P.57 Sea Prince T.1 s prodlouženou příďí. V dubnu 1953 vstoupila do operační služby vylepšená verze Percival P.57 Sea Prince C.2. Letouny v Royal Navy sloužily pro cvičné, navigační, protiponorkové a transportní účely.

Percivaly verzí C1, T.1 a C.2 byly v polovině 60. let 20. století nahrazeny letouny De Havilland Sea Devon a De Havilland Sea Dove. Přesto řada z nich ještě dosluhovala v 70. letech 20. století.

Bylo celkem postaveno 75 letadel ve všech verzích. Sloužily v civilních operacích ve 13. zemích světa. Ve vojenské službě byly provozovány kromě Spojeného království v Austrálii pod označením Percival Prince Mk.3 a v Thajsku jako Percival P.50 Prince 3A.

Technická data:

Rozpětí (m)	17,07
Délka (m)	14,12
Výška (m)	4,90
Max. rychlost (km/hod)	359
Dolet (km)	740
Dostup (m)	6700

A brief history of the Percival Prince

The development of the Percival Prince aircraft began in the immediate post-war period. It was based on its predecessor, the Percival Merganser, to which it was quite similar, only much heavier and larger.

It was a light twin-engine, high-wing transport aircraft with retractable tricycle landing gear. Two Alvis Leonides engines of 520 hp each were installed with the designation 501/4, later 502/4.

The prototype P.50 Prince first flew on 13 May 1948 at Luton. The first three Sea Prince C1s entered service in February 1953 and served with the Royal Navy. Within a few years, Percival modified the aircraft to produce 6 more variants. The Sea Prince C1 was followed by a trainer version designated the Percival P.57 Sea Prince T.1 with an extended nose. In April 1953, an improved version of the Percival P.57 Sea Prince C.2 entered operational service.

The Percival versions C1, T.1 and C.2 were replaced by the De Havilland Sea Devon and De Havilland Sea Dove in the mid-1960s. Nevertheless, many of these were still in service in the 1970s.

A total of 75 aircraft were built in all versions. They served in civilian operations in 13 countries. In military service, apart from the United Kingdom, they were operated in Australia as the Percival Prince Mk.3 and in Thailand as the Percival P.50 Prince 3A.

Technical data.

Span (ft)	56
Length (ft)	46 4'
Height (ft)	16 1'
Max. speed (mph)	223
Range miles	460
Service ceiling (ft)	22000

PLASTIKOVÉ DÍLY

PLASTIC PARTS

4

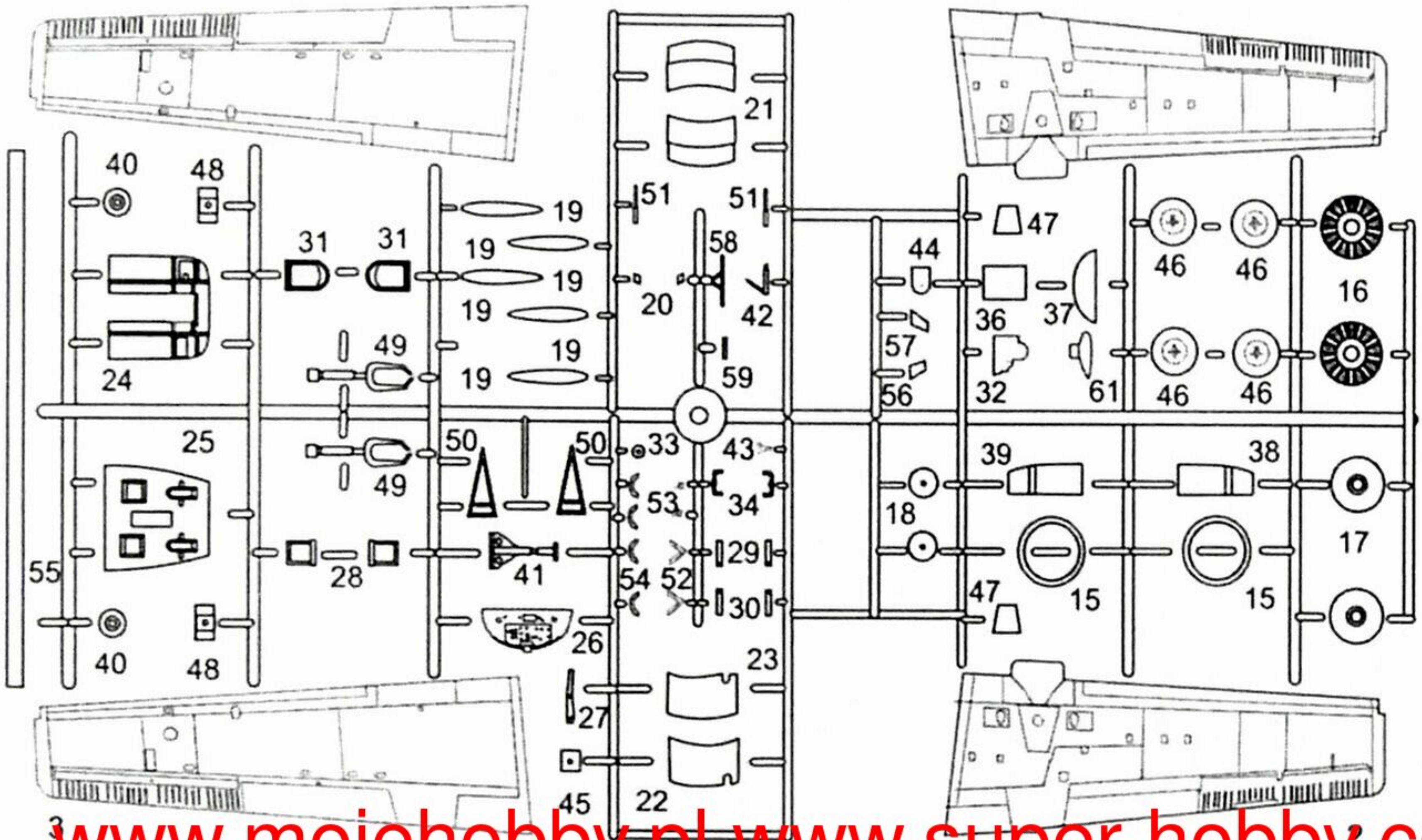

www.mojeobby.pl www.super-hobby.com

5

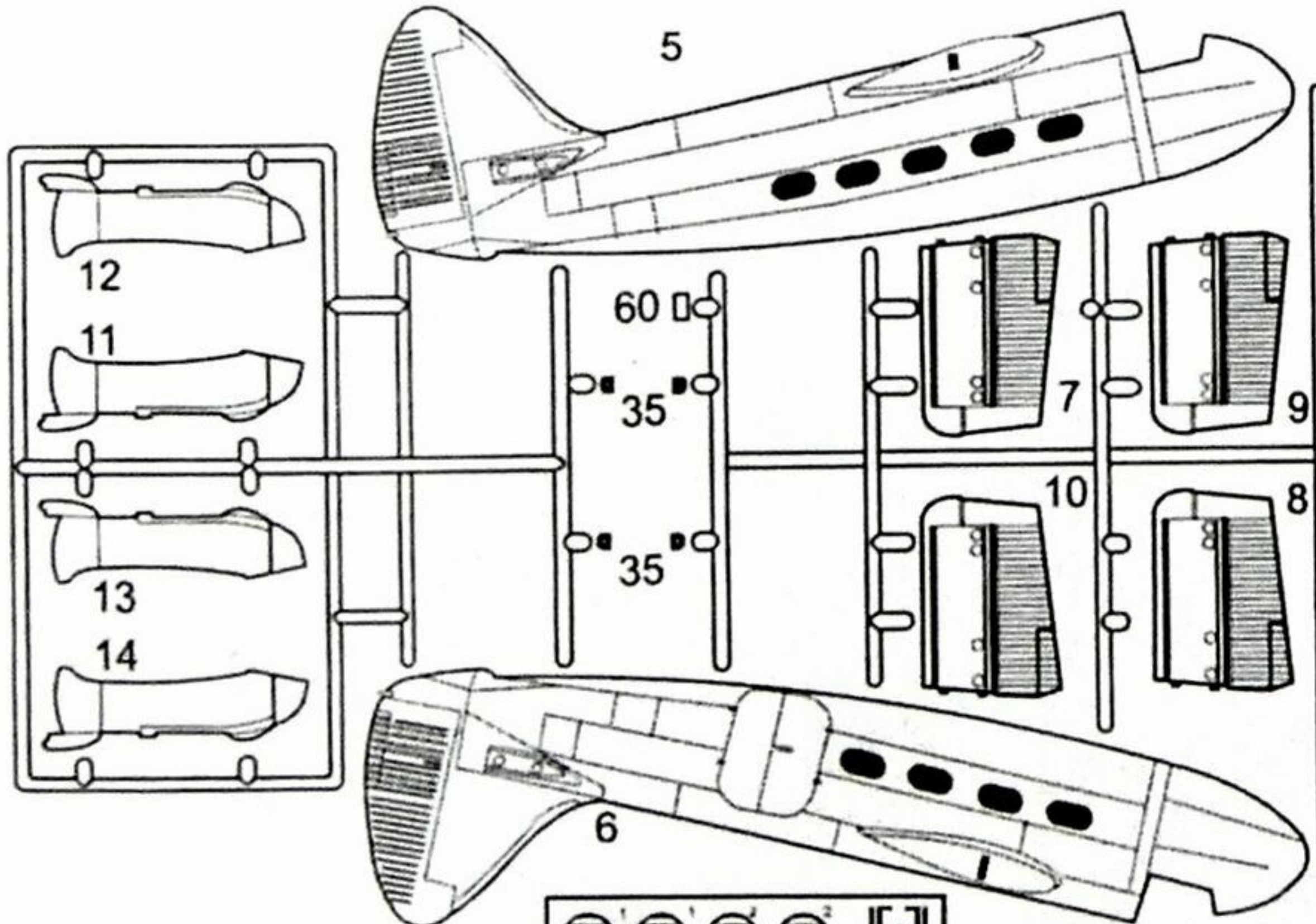

PRŮHLEDNÉ DÍLY

CLEAR PARTS

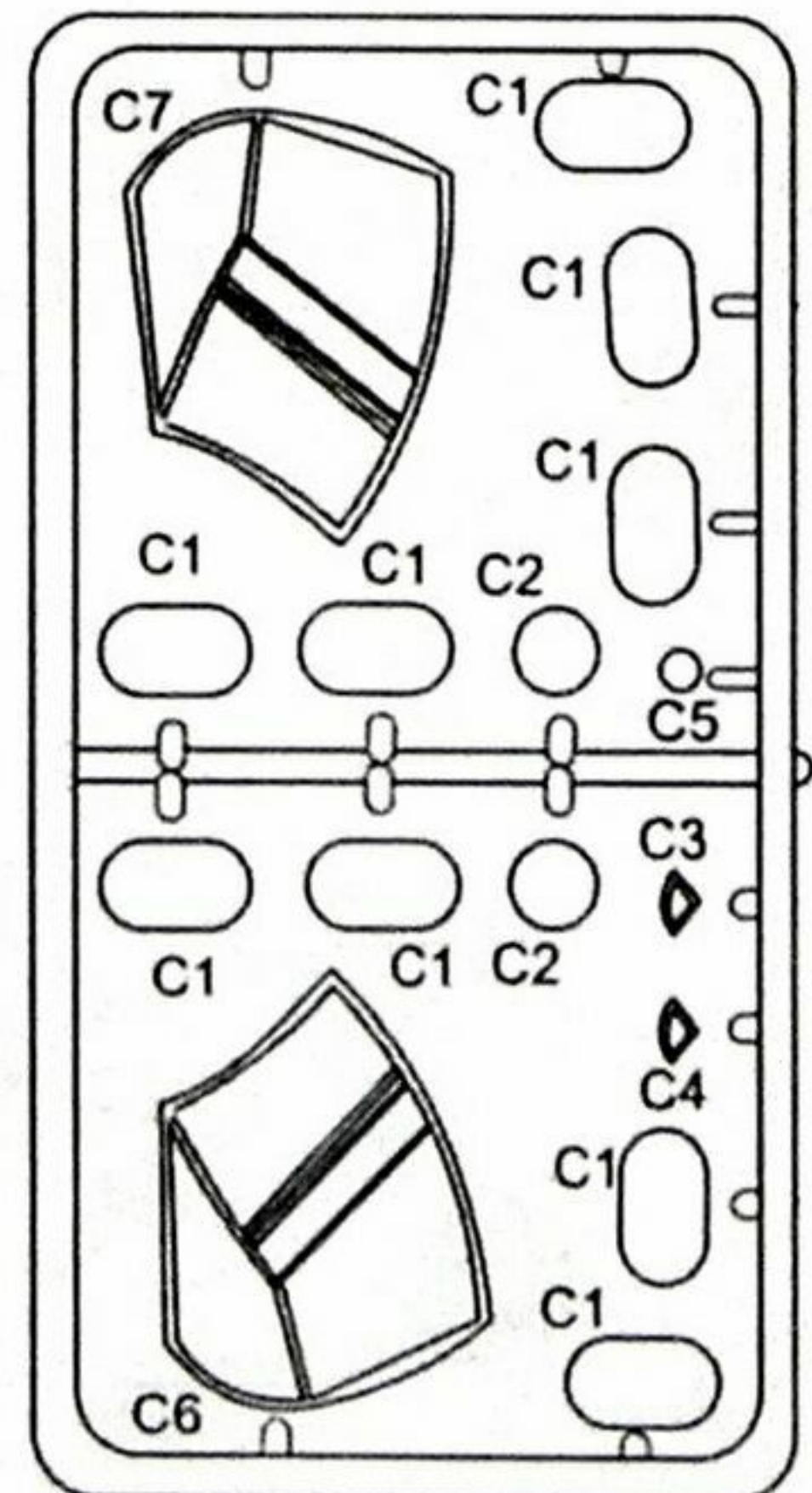

drawing is not to scale 1/72
kresba není v měřítku 1/72

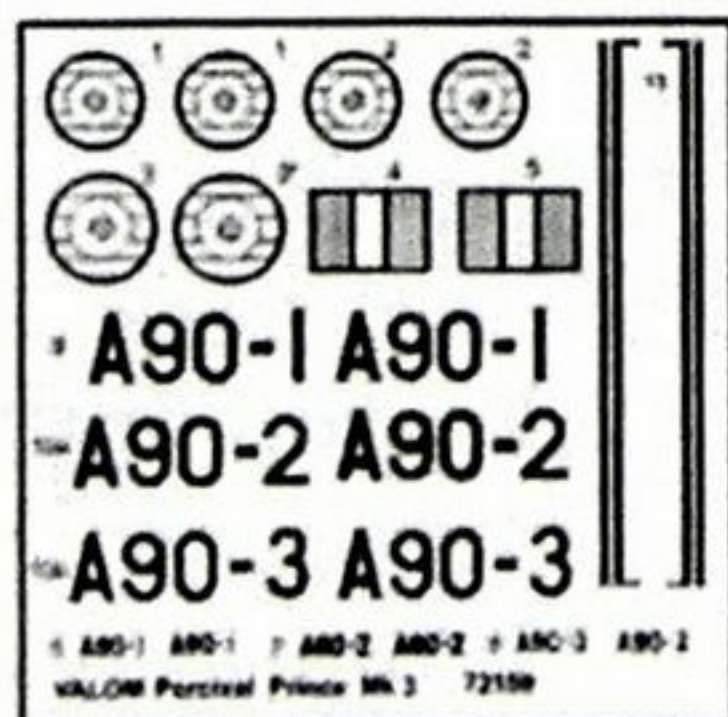
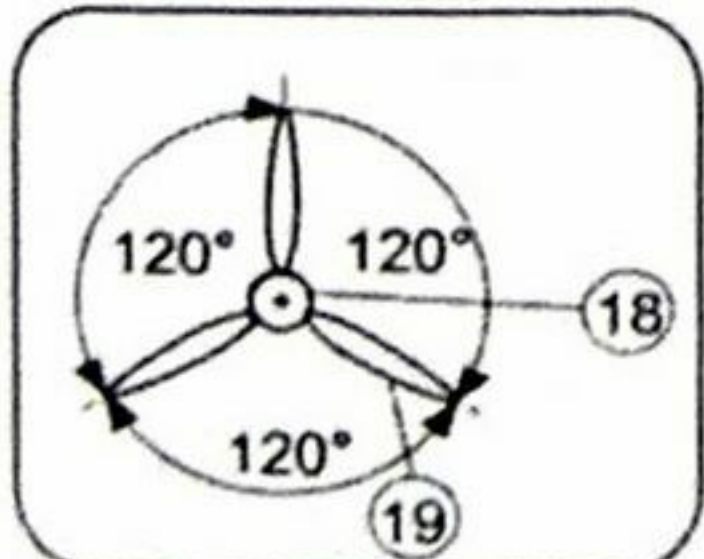

obtisky decals

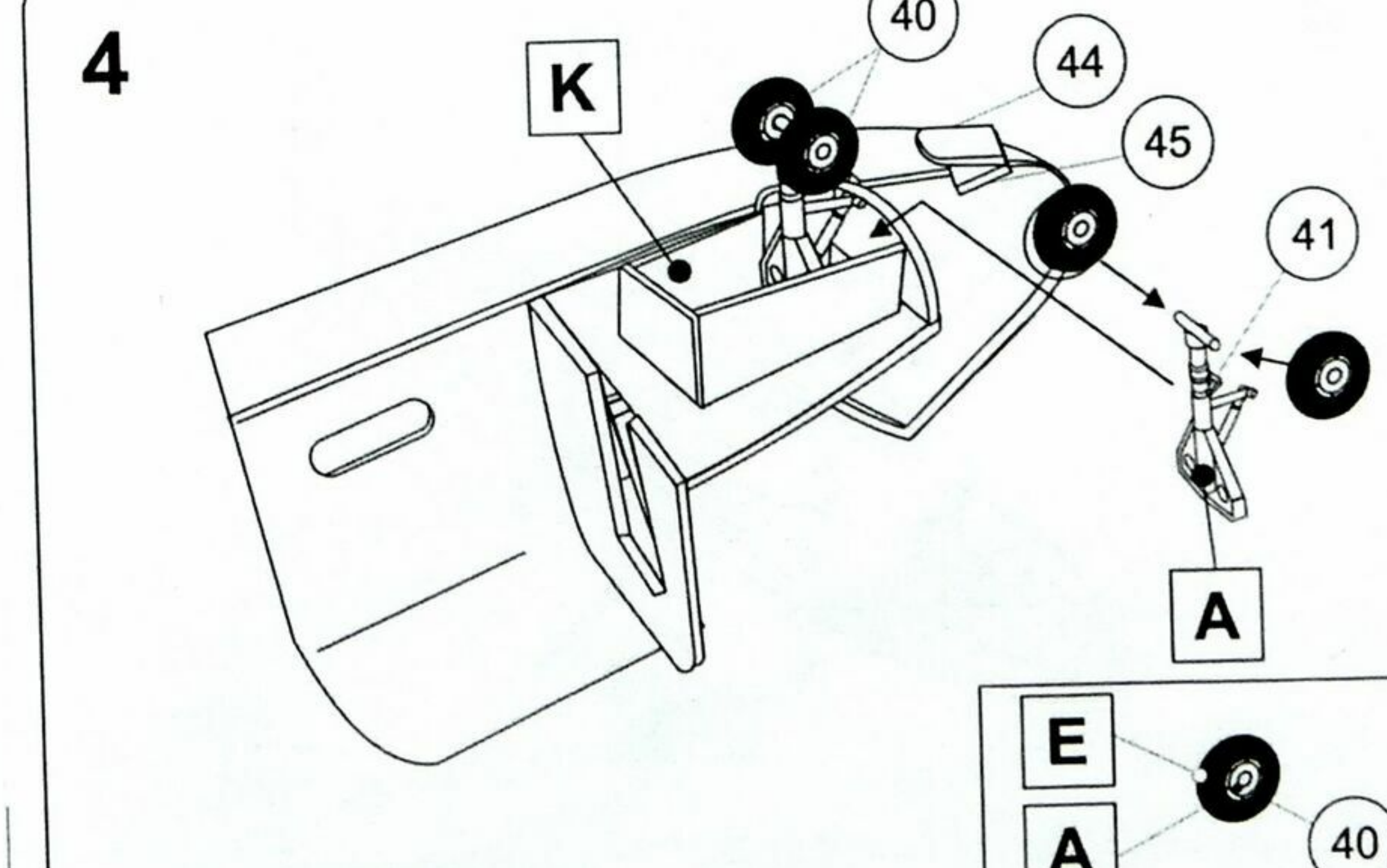
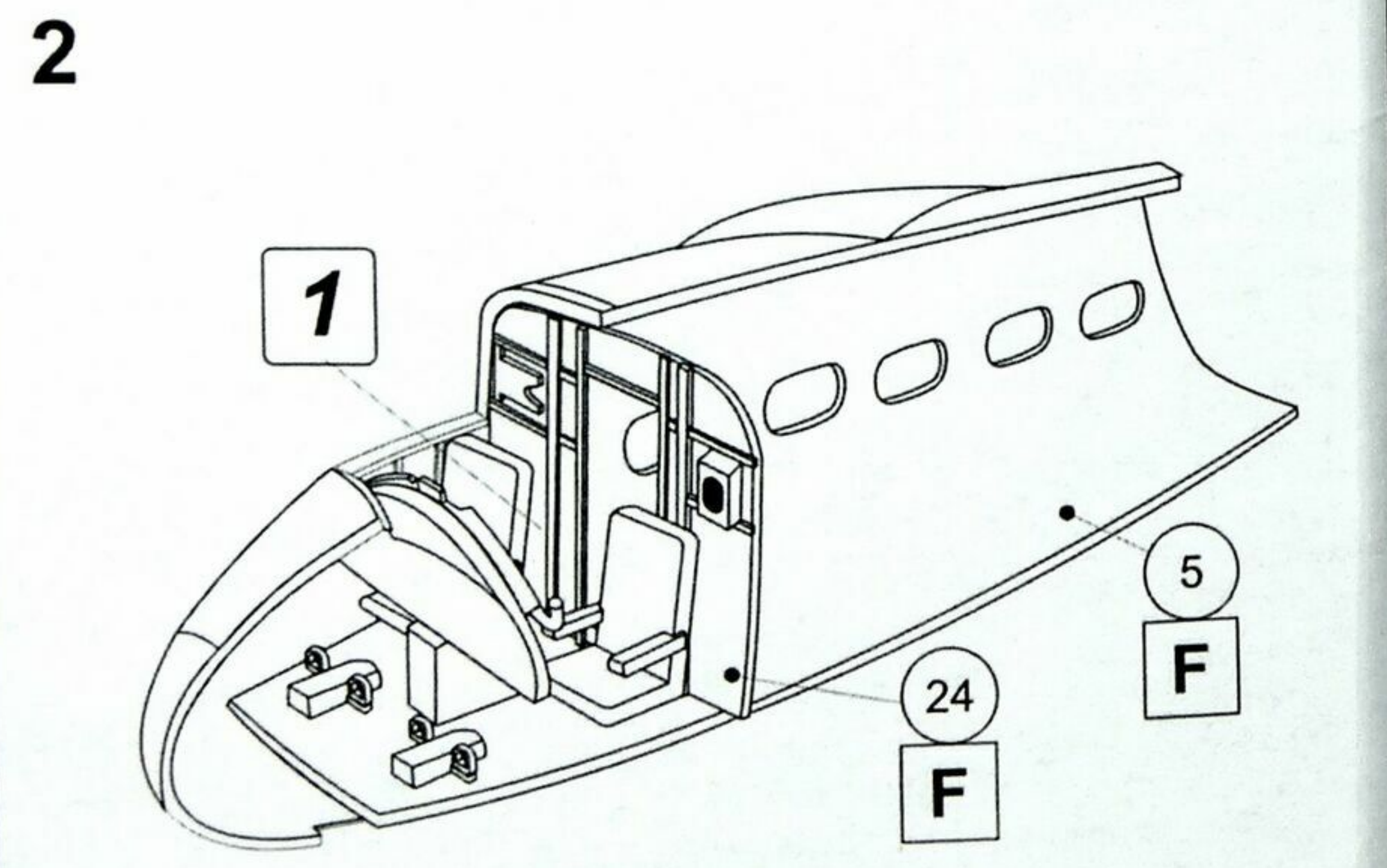
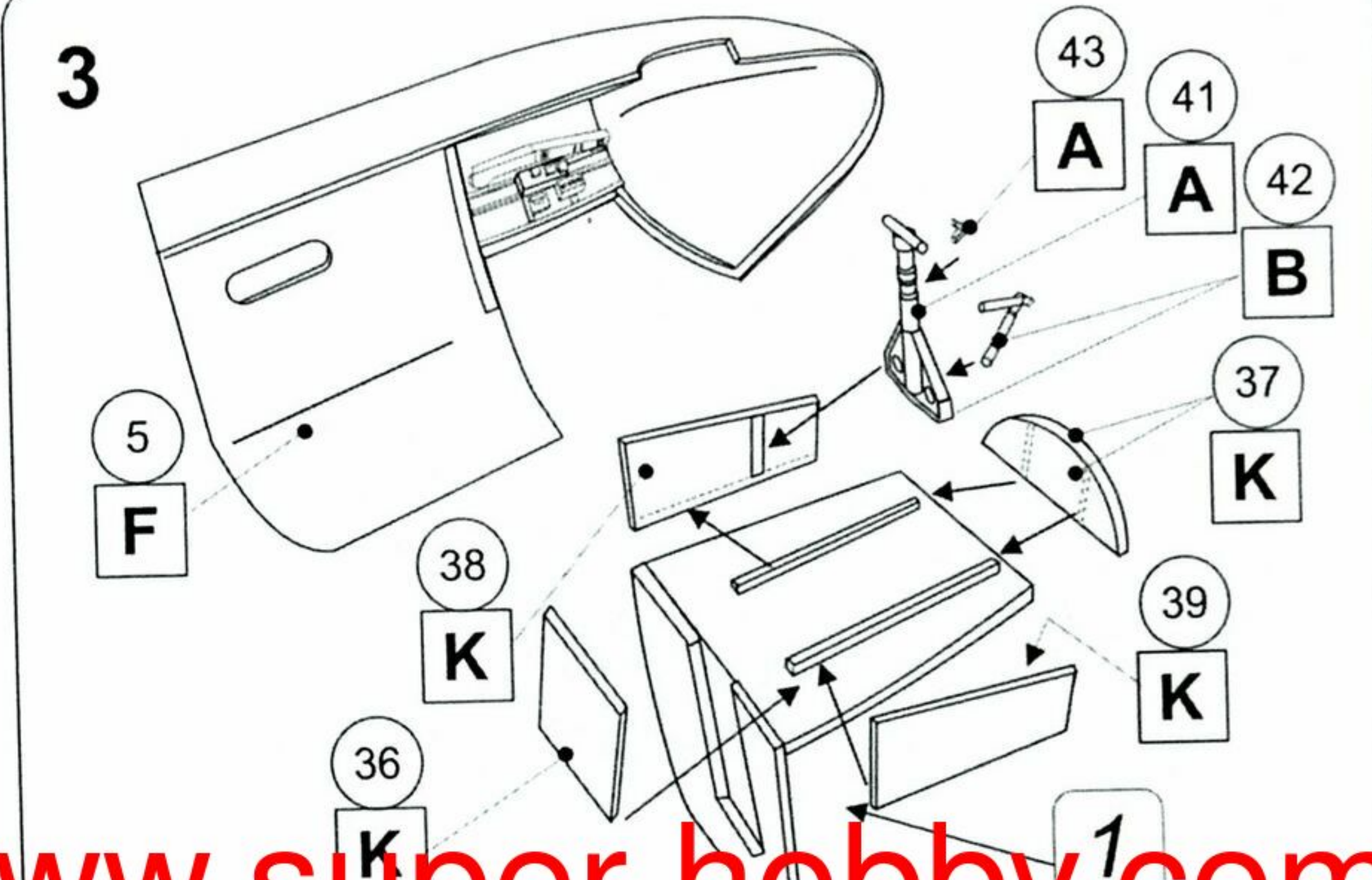
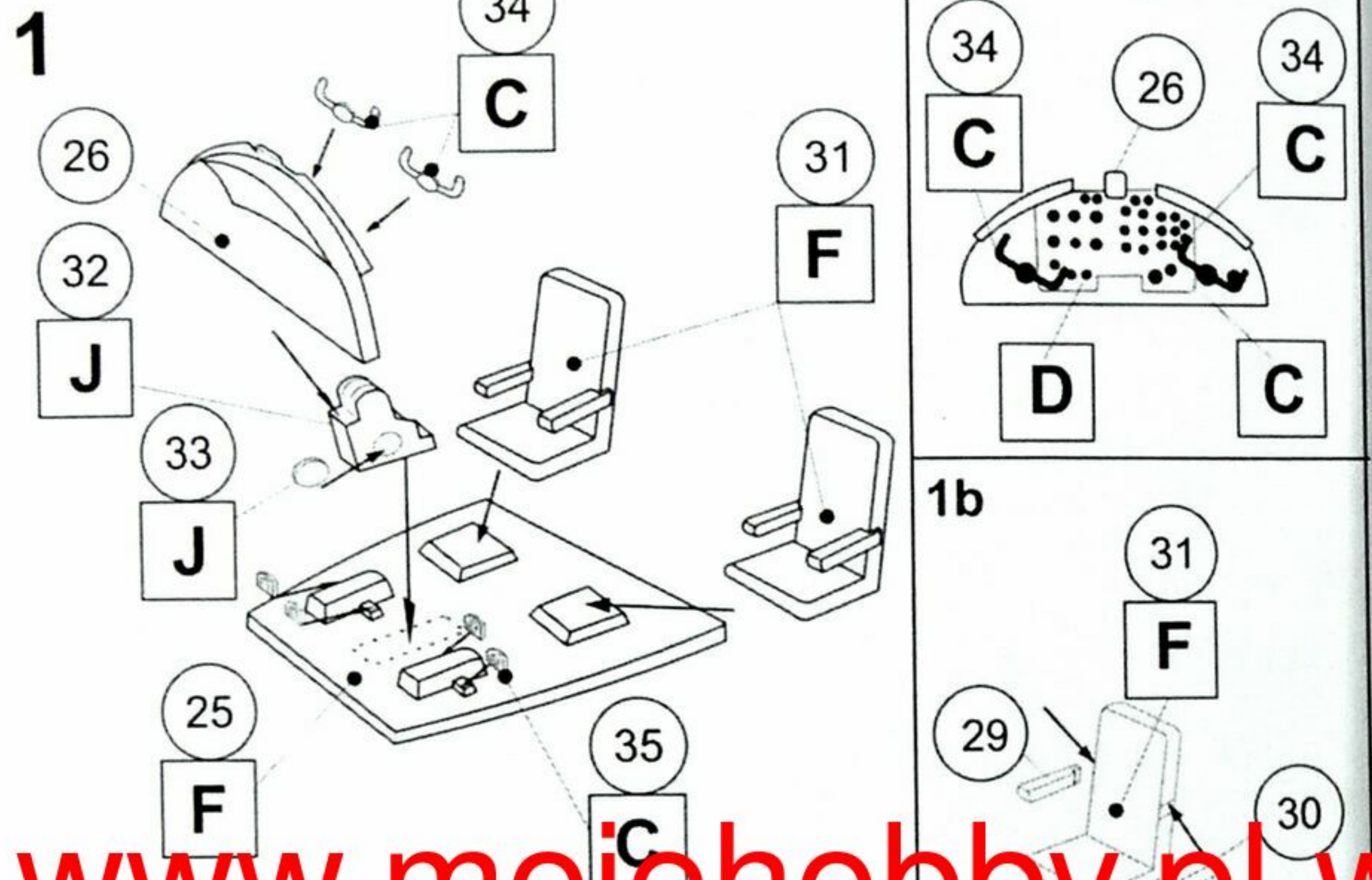

www.mojehobby.pl www.super-hobby.com

5

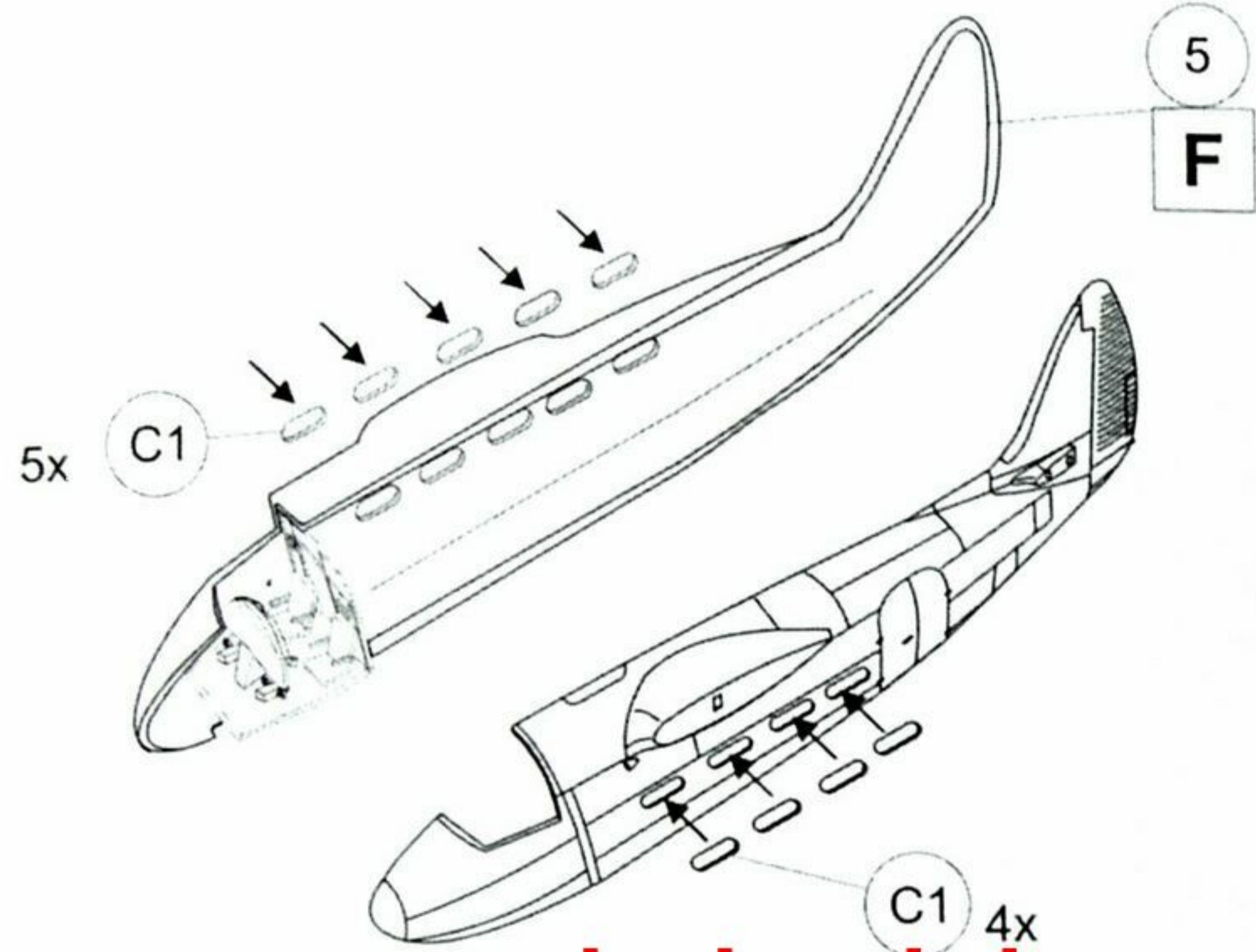

7

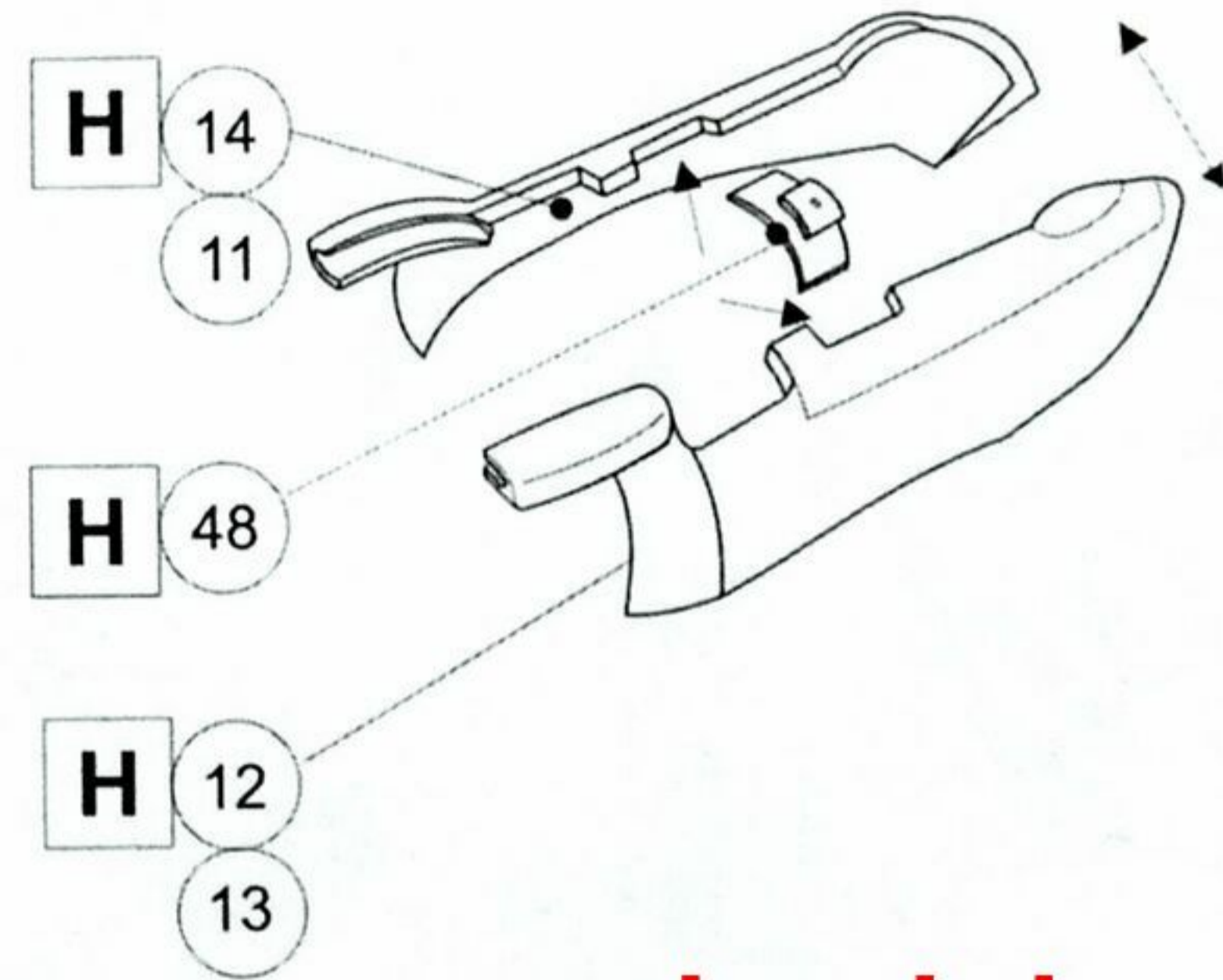

www.moje hobby.pl www.super-hobby.com

6

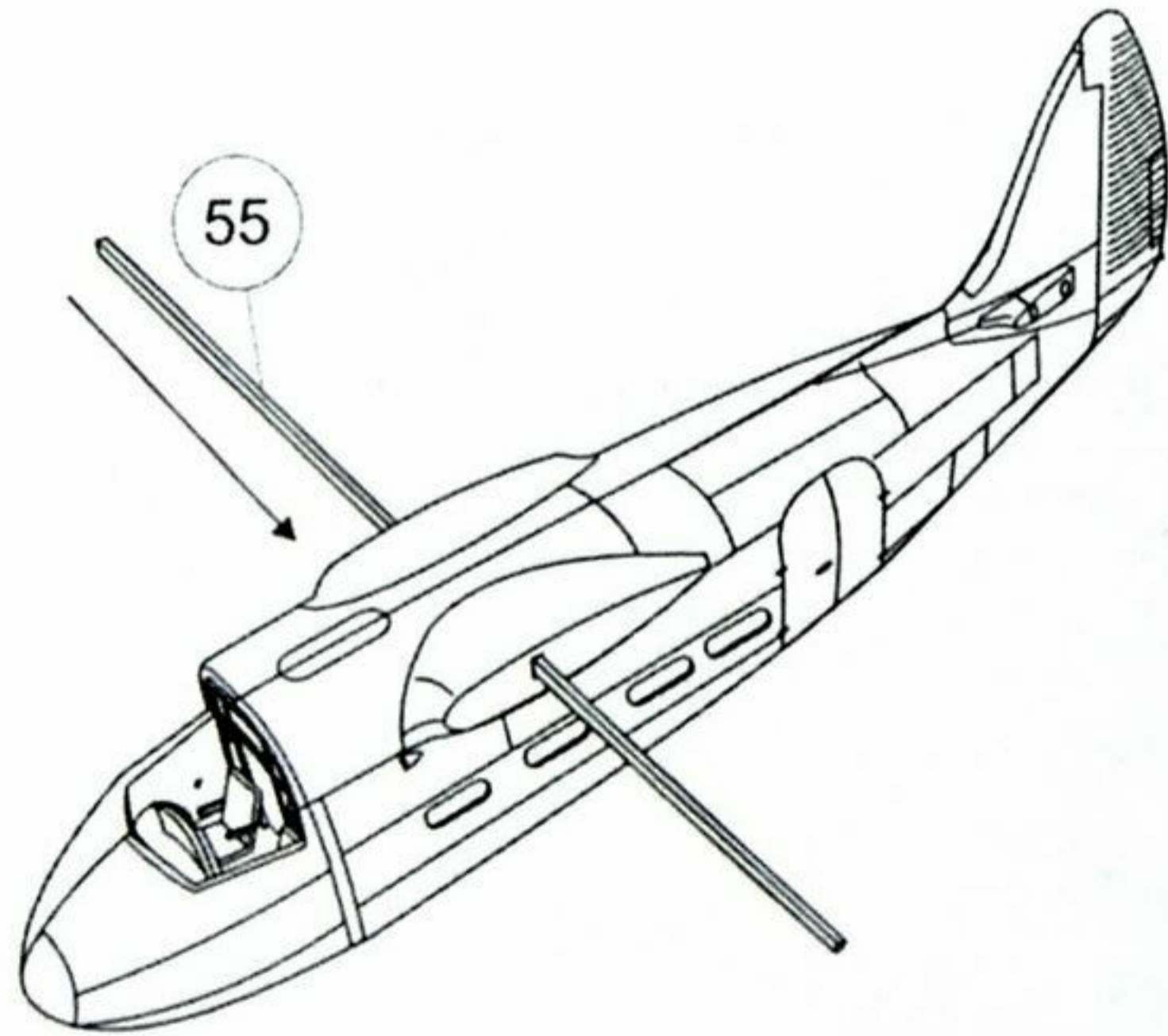

8

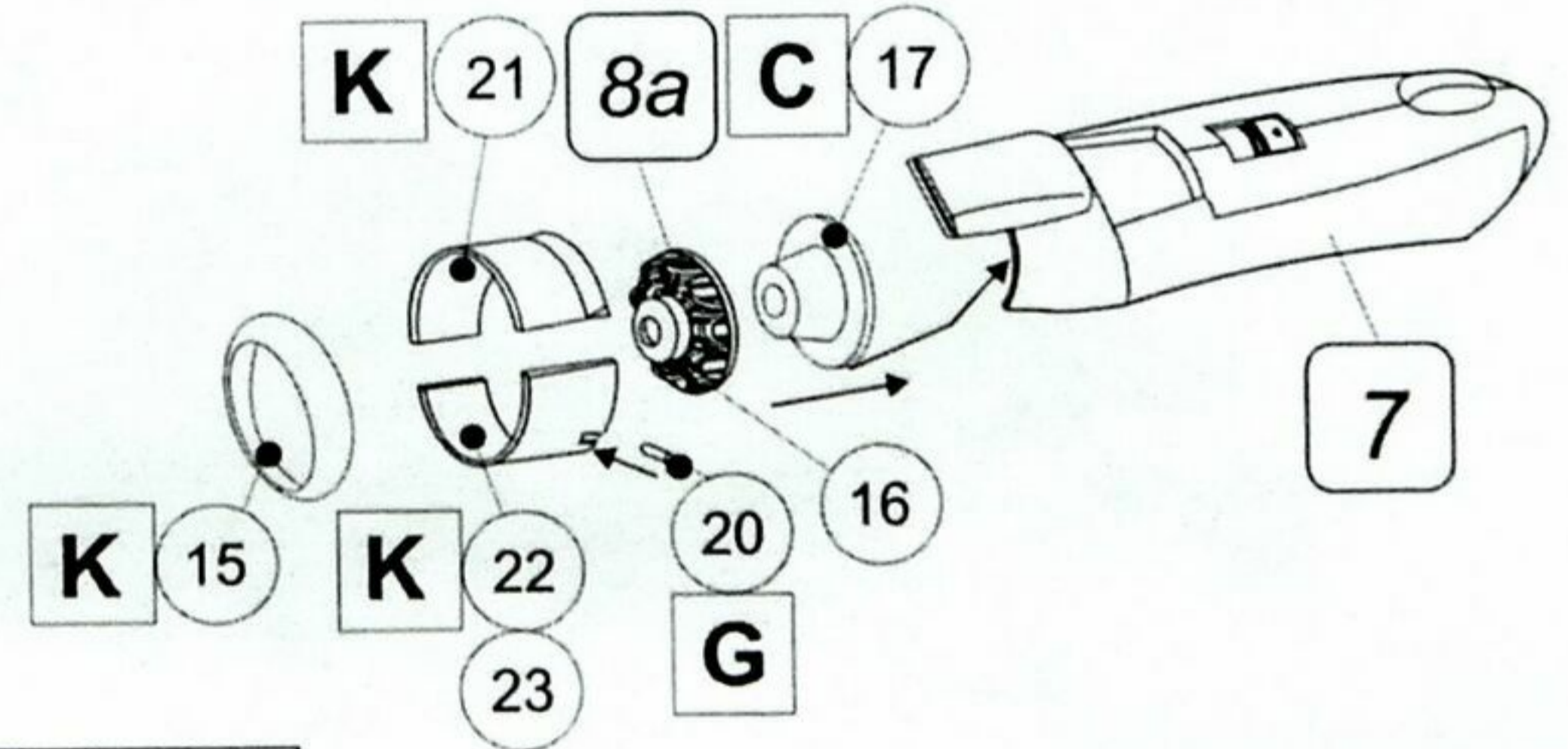

8a

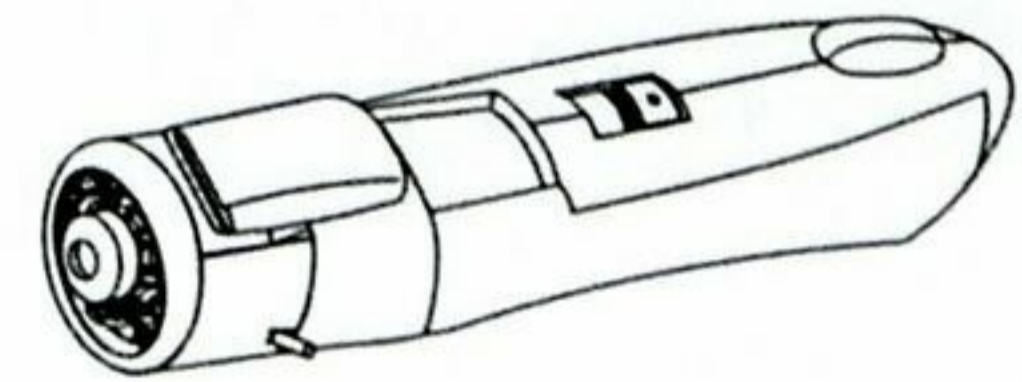
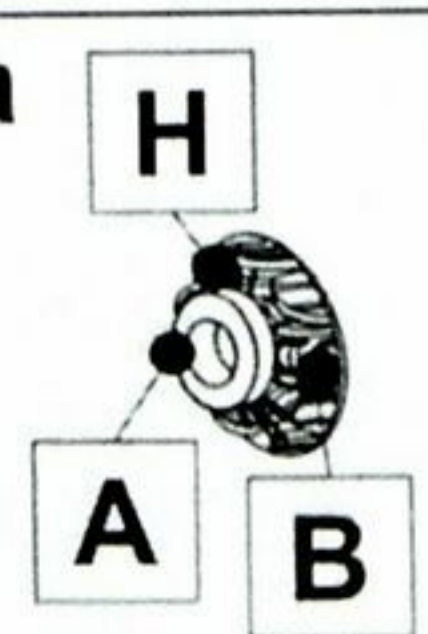

9

levá left

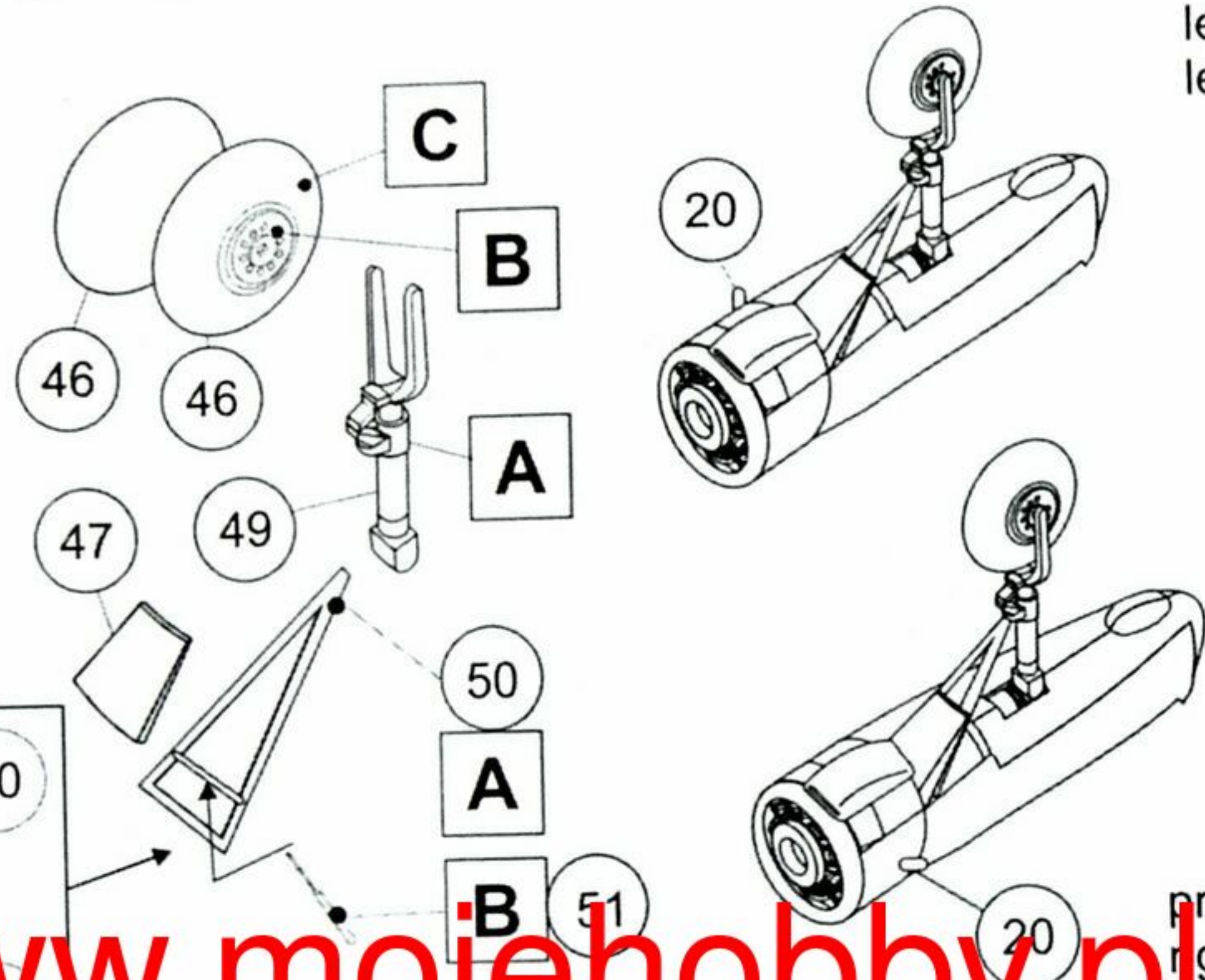

9a

www.moje Hobby.pl www.super-hobby.com

11

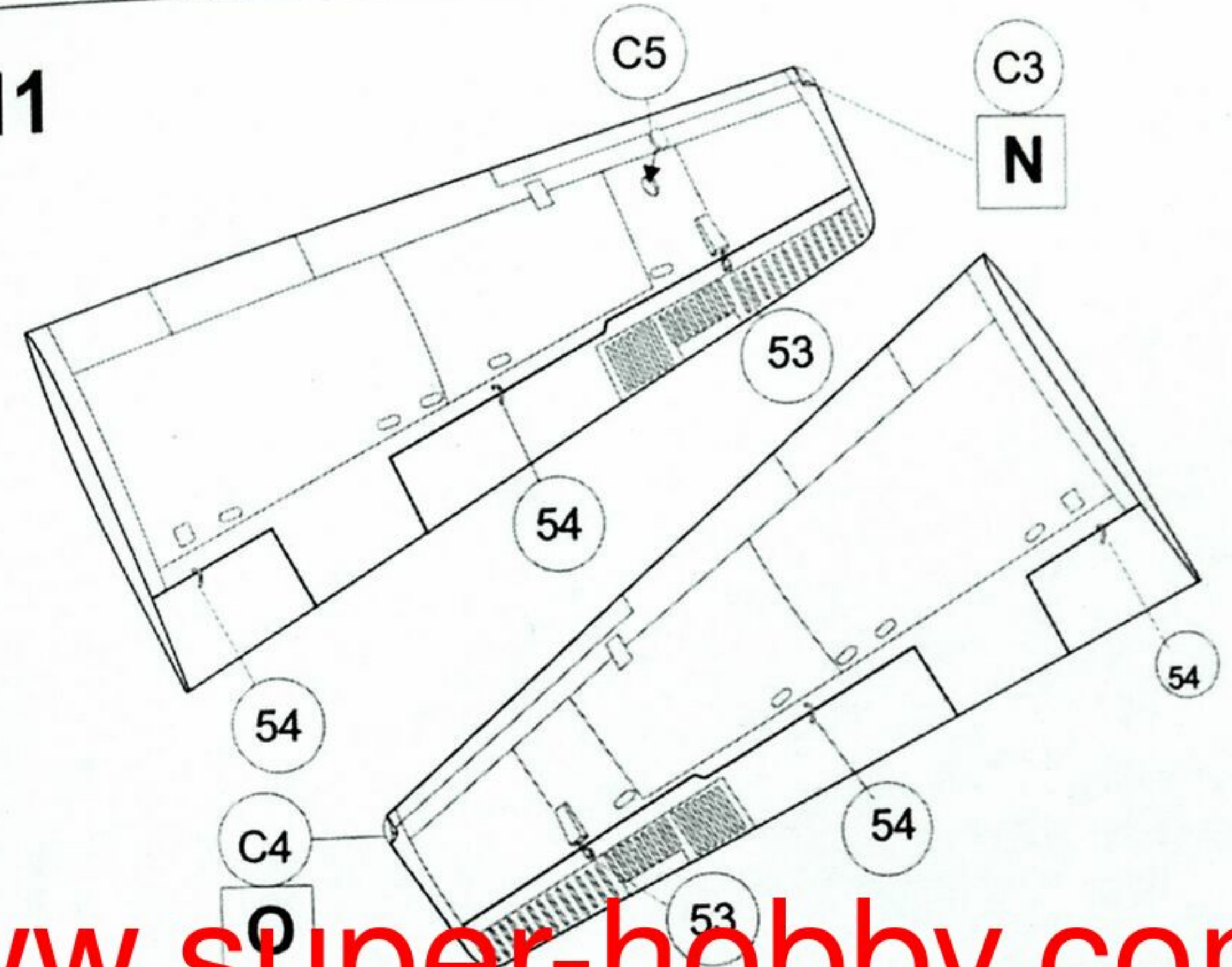

10

levá left

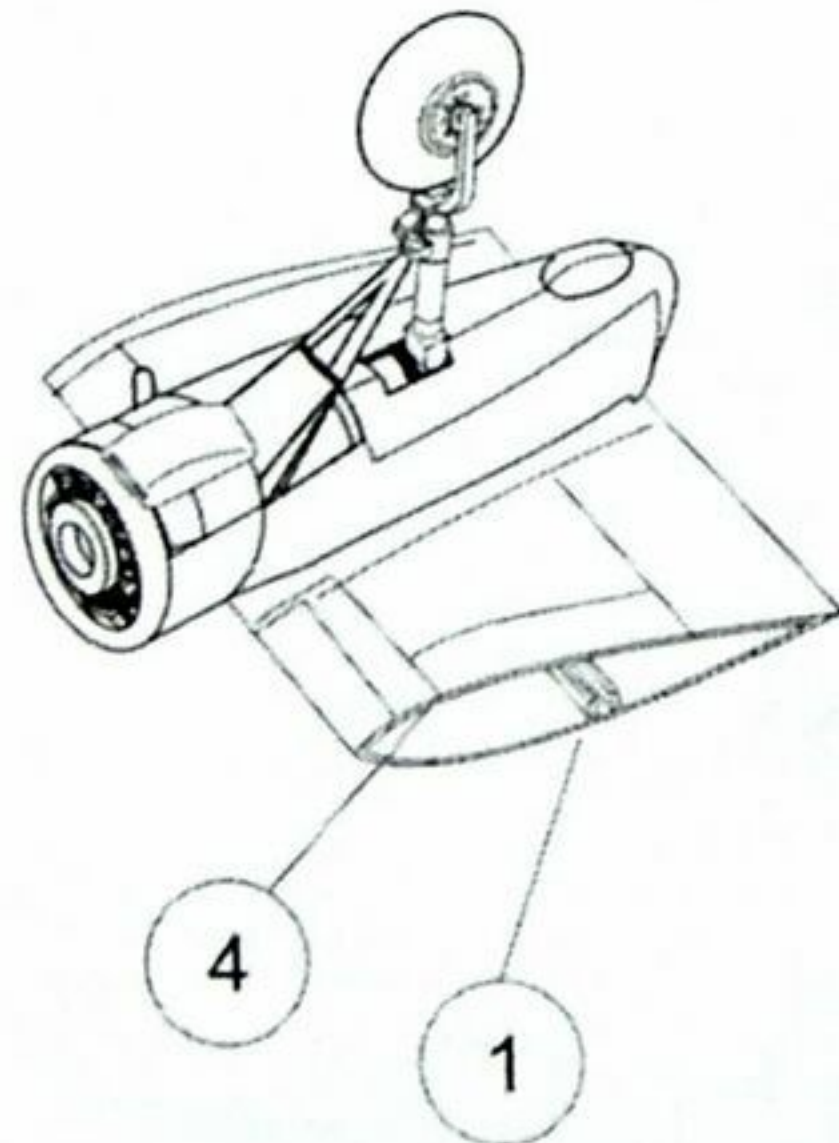

pravá right

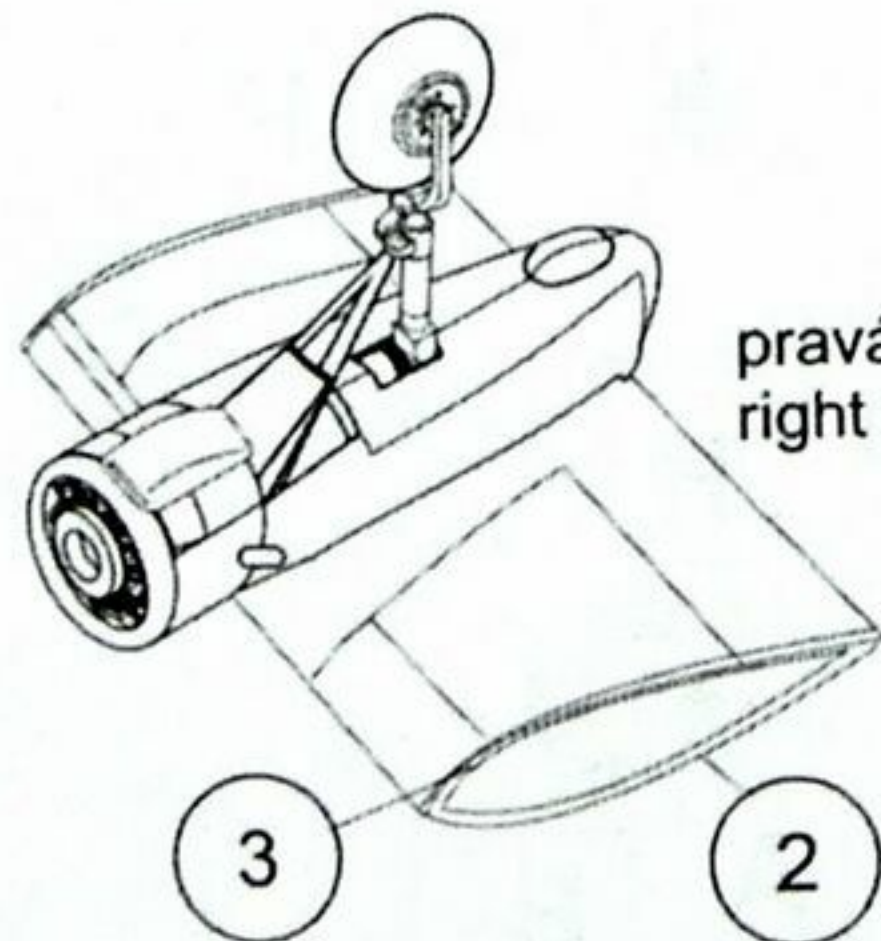

12

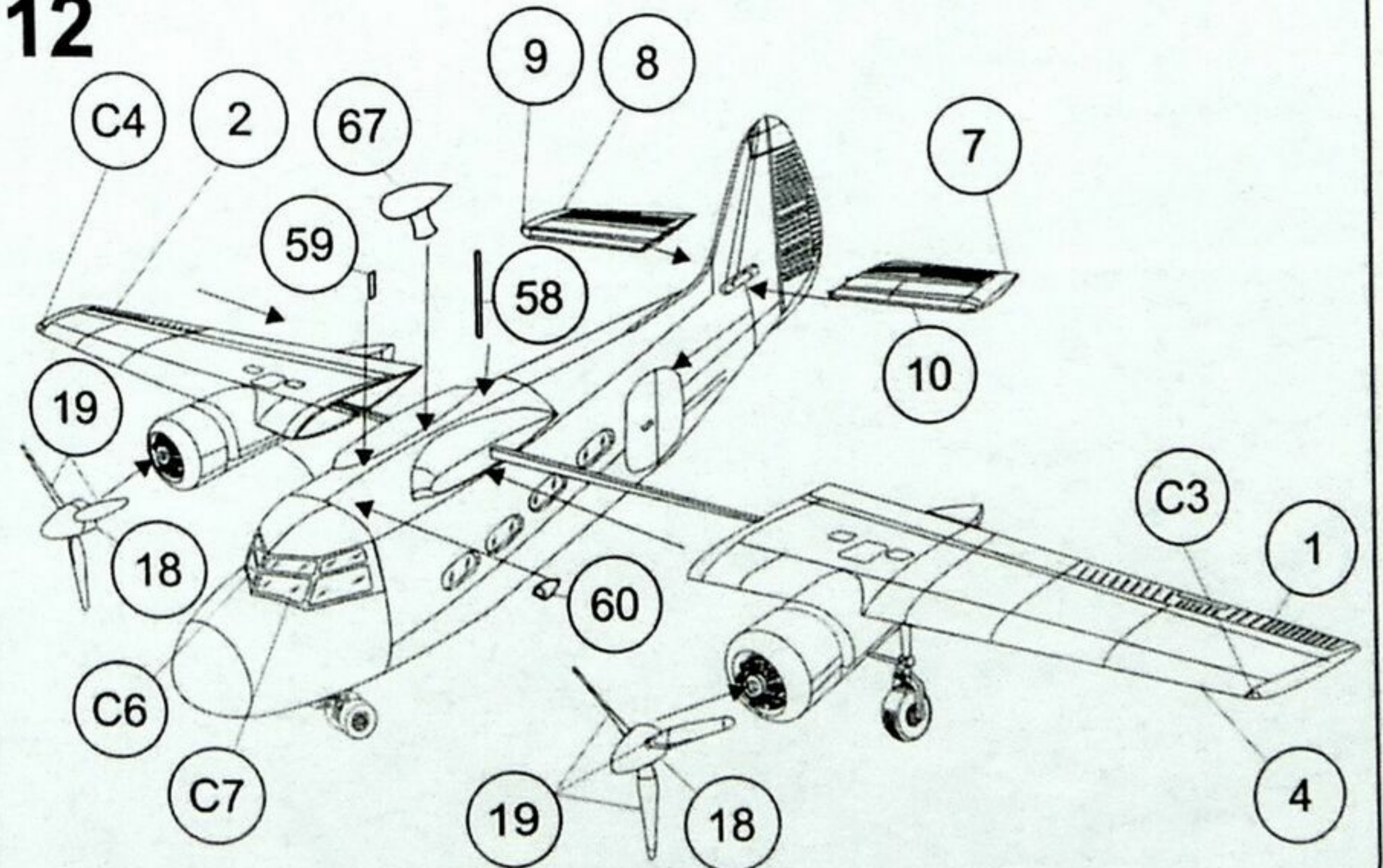

13

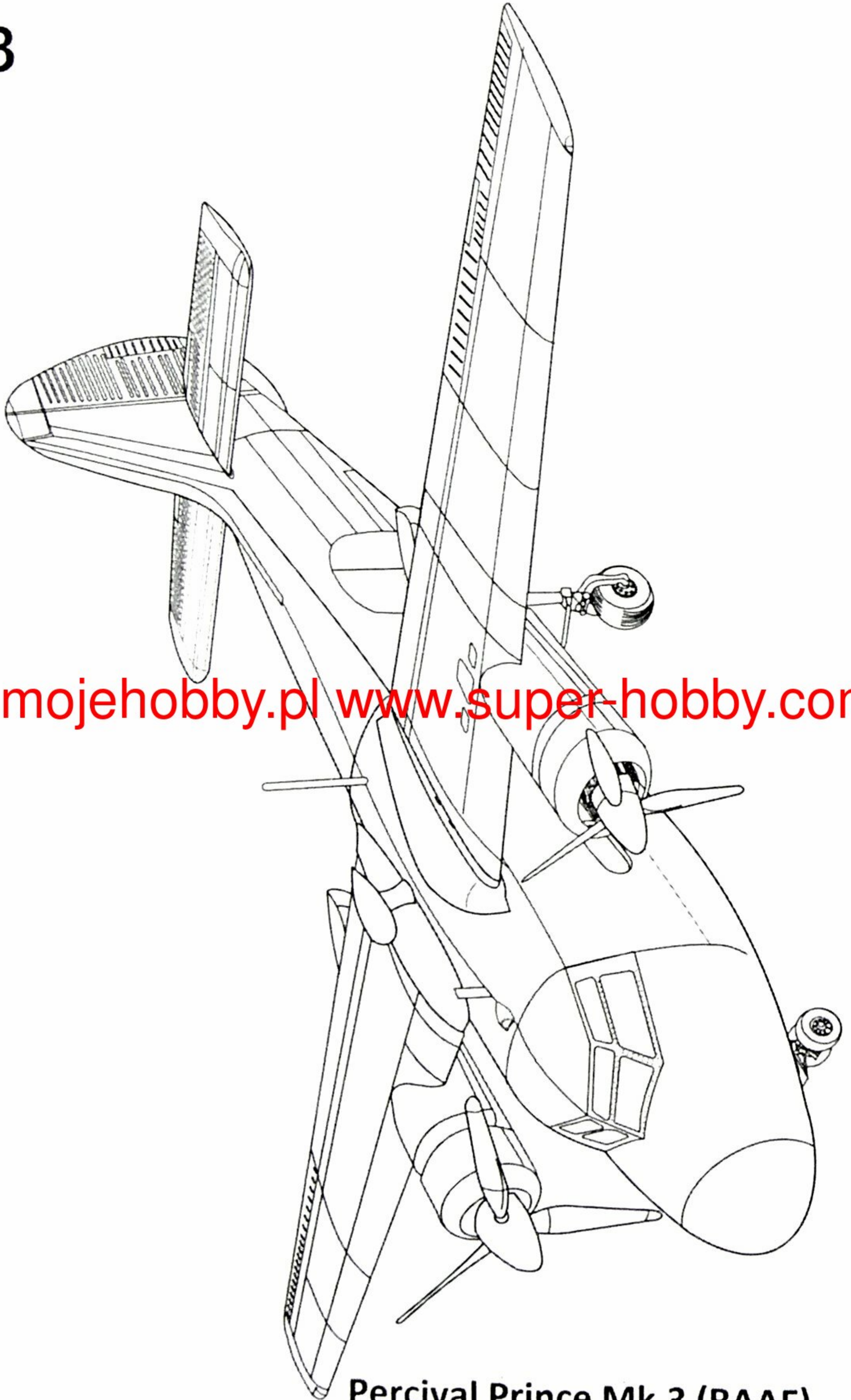

www.mojehobby.pl www.super-hobby.com

Percival Prince Mk.3 (RAAF)

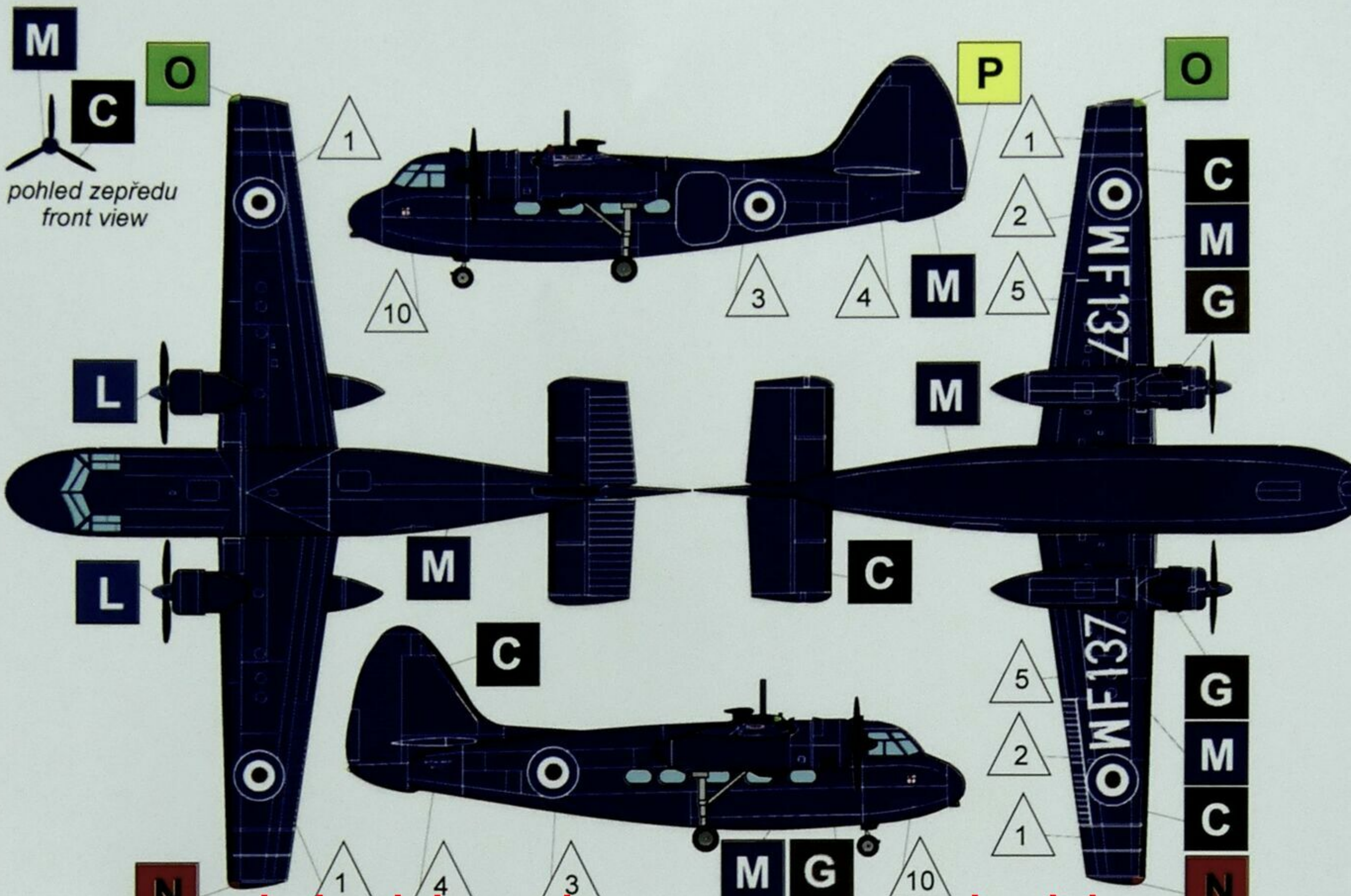

www.moje hobby.pl www.super hobby.com

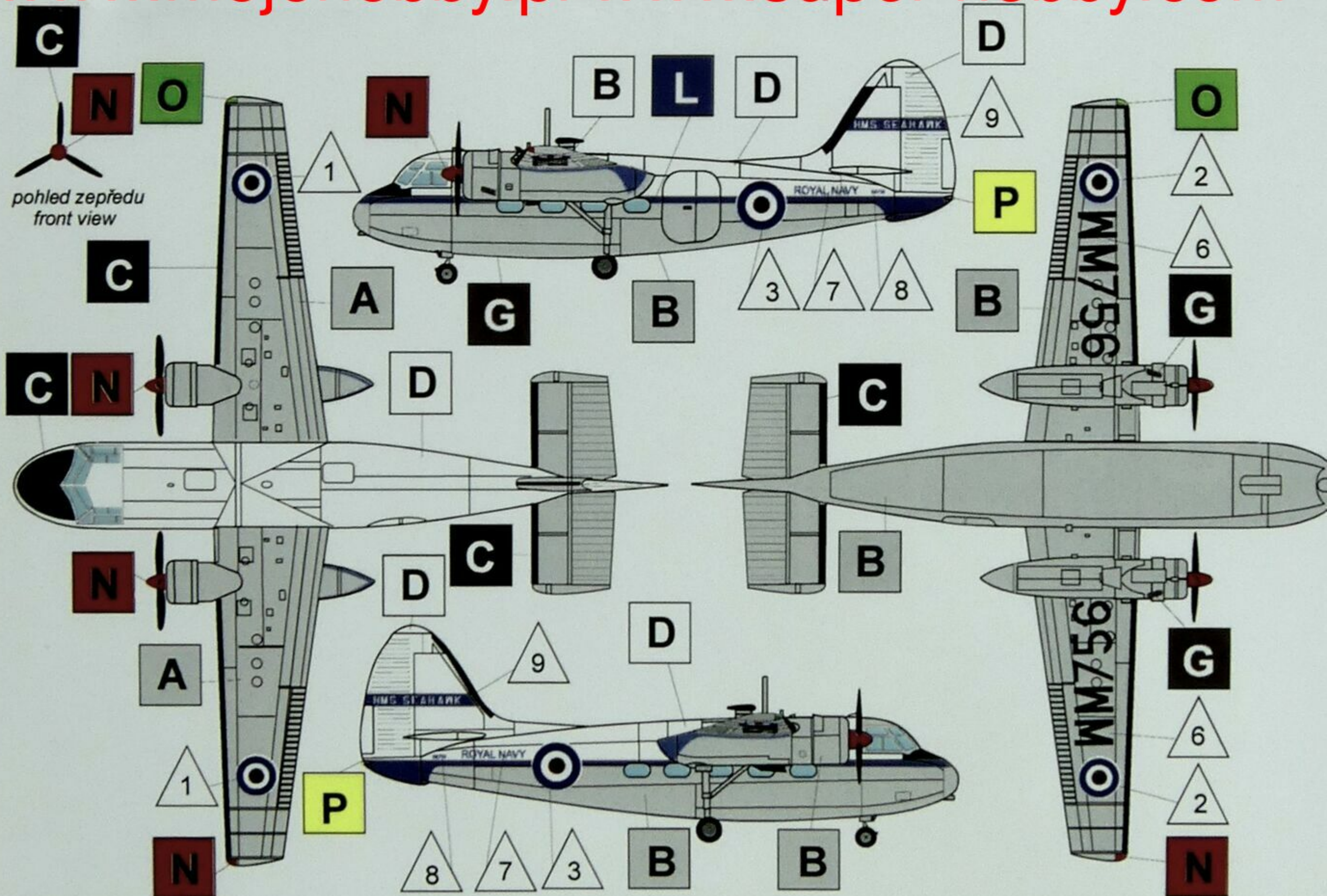

Percival P.50 Sea Prince C1, WM756, RNAS Culdrose (HMS Seahawk)