

AIR CANADA

McDONNELL DOUGLAS DC-9

5 STEP NUMBERS
NUMÉROS DES INSTRUCTIONS

Plastic Part Numbers
Numéros des pièces en plastique

Optional
Facultatif

No Not Cement
Ne Pas Coller

Cement here only
Coller ici seulement

21 Repeat several times
Répéter plusieurs fois

Remove
Enlever

Refer to ...
Se référer à

Decal
Décalcomanie

The McDonnell Douglas DC-9 can justifiably claim to be by far the best-selling twin-jet airliner in production today. A total of 1,034 DC-9s were on order by December 1979, and six basic models are now in service or in production. A fuselage stretch of 15ft (for up to 115 seats maximum), an increase in operating weights and modified wing flap and slat arrangement produced the Series 30, the type depicted by this kit. All versions of the DC-9 are offered in all-freight, quick-change cargo-passenger or mixed-traffic passenger-cargo layouts. Performance for the DC-9-30 includes a maximum cruise speed of 497kt at 25,000ft (7,620m), an economical cruise range of 1,370n.m. and a maximum take-off weight of 108,000lb (48,987kg). Powerplant: two 14,500lb (6,577kg) thrust Pratt & Whitney JT8D-9 engines. Dimensions: span 93ft 4in (28.45m), length 119ft 4 in (36.37m), height 27ft 5in (8.35m).

CARMICHAEL AIRLINER MODELS LTD.

Leduc (Alberta) Canada T9E 3J3

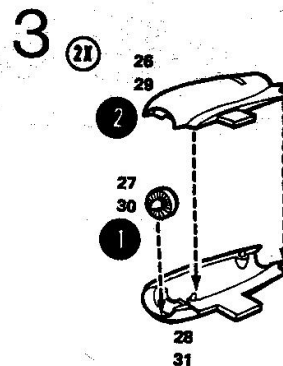
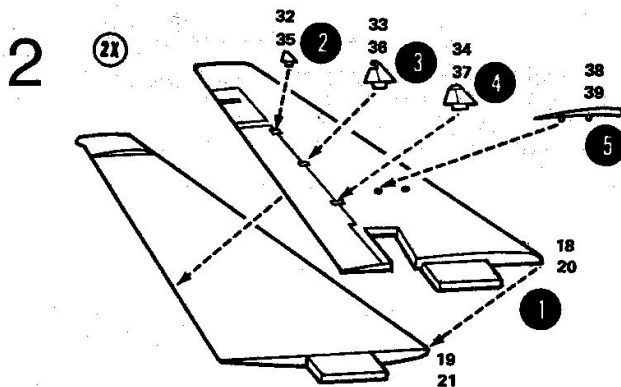
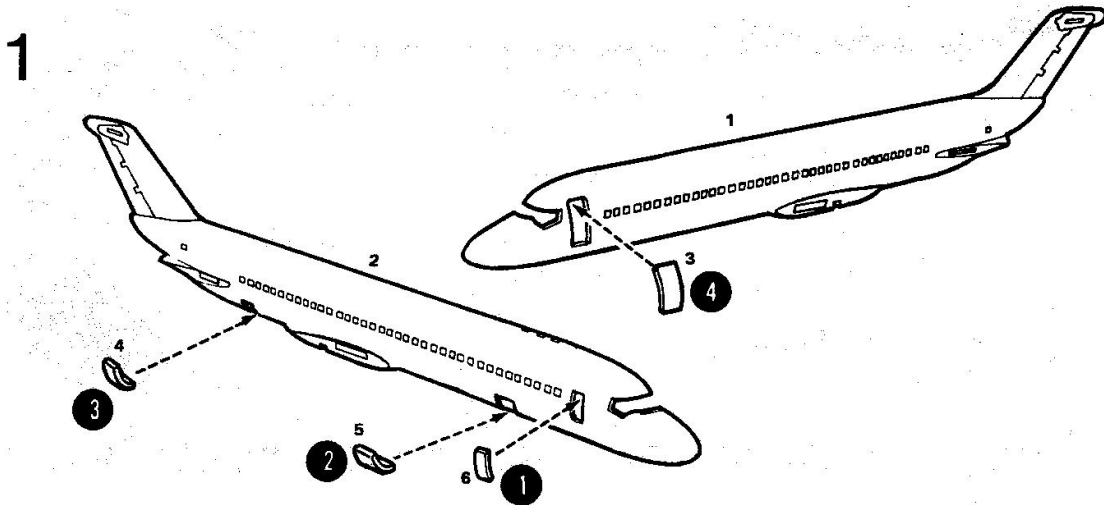

4

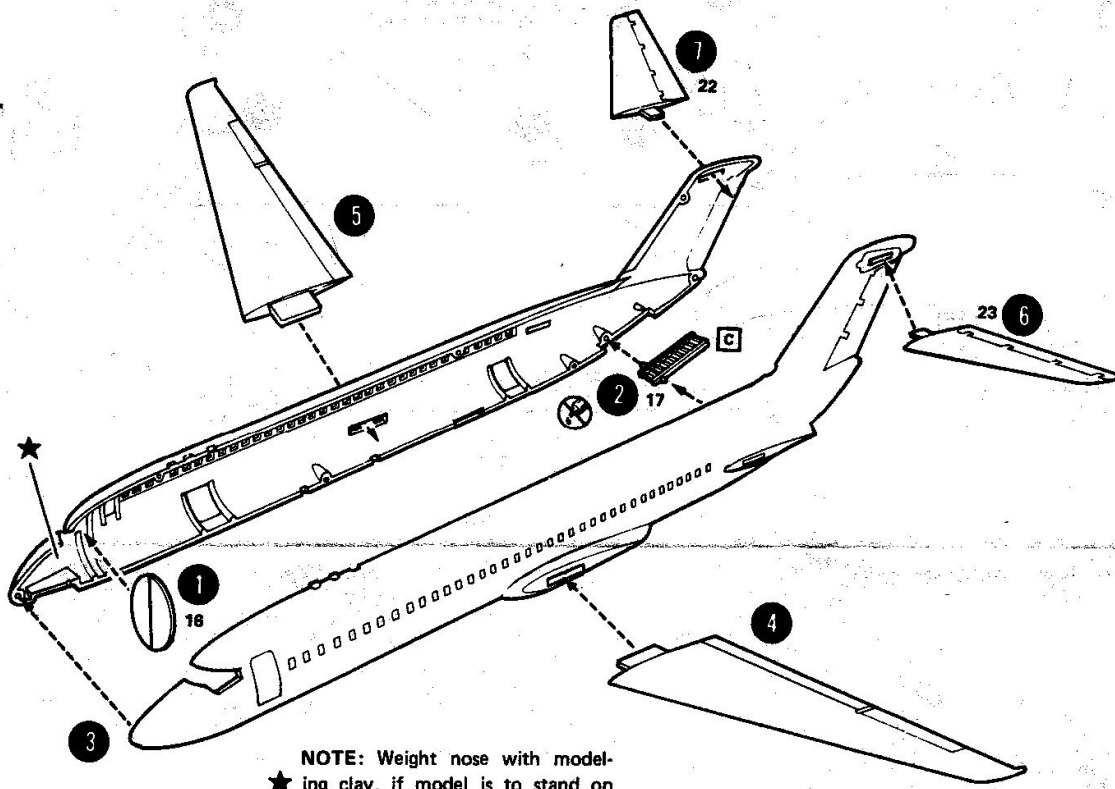

NOTE: Weight nose with modeling clay, if model is to stand on landing gear.
★

5

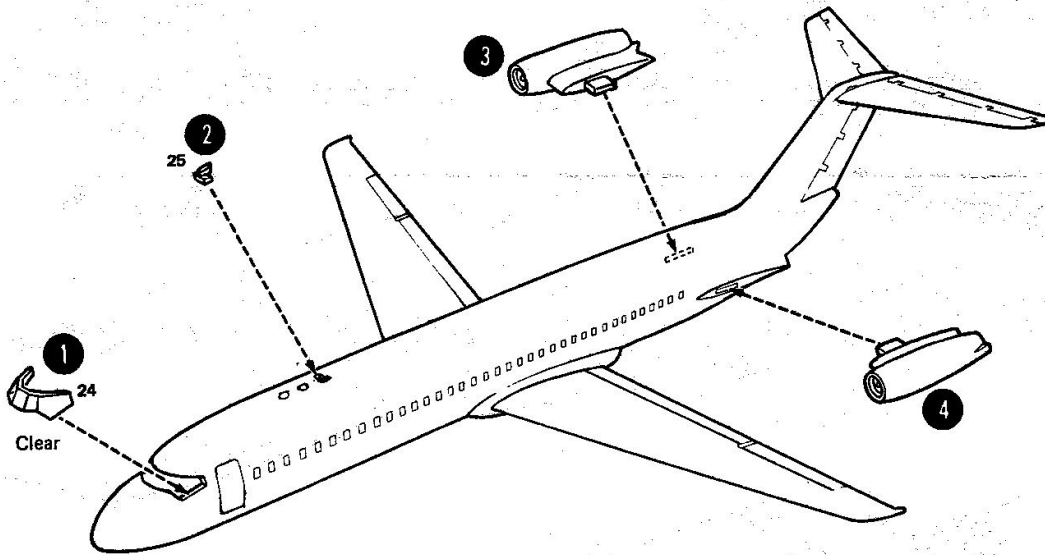

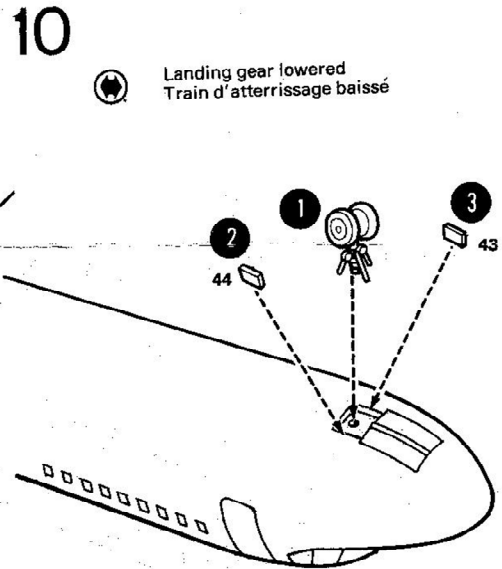
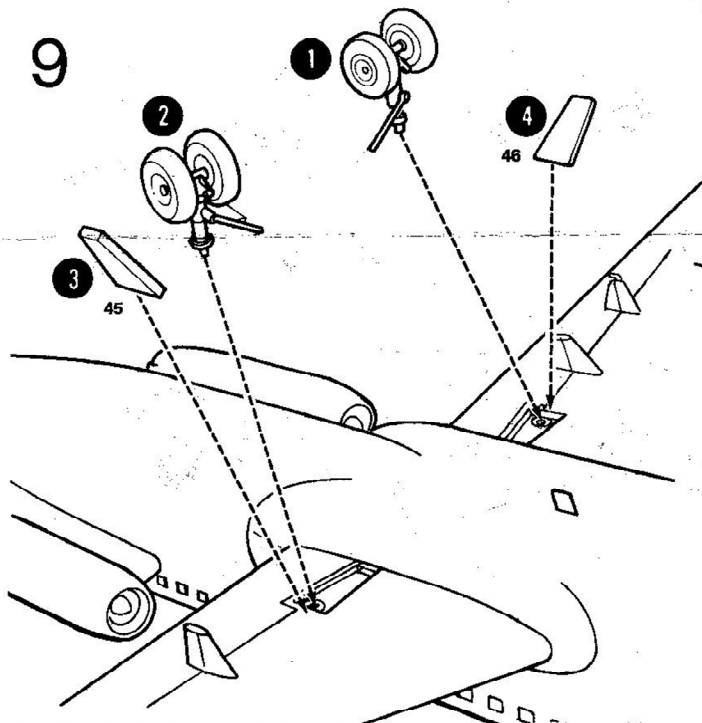
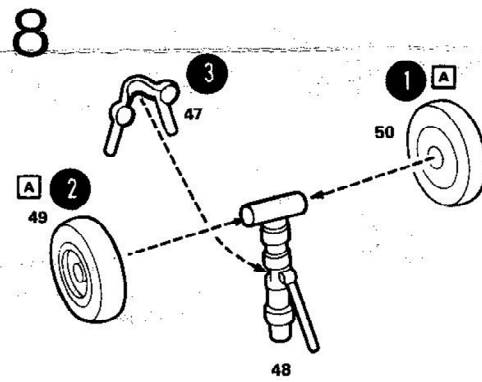
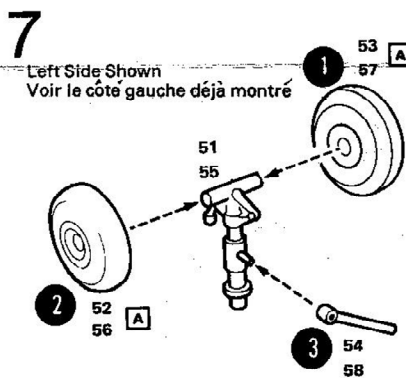
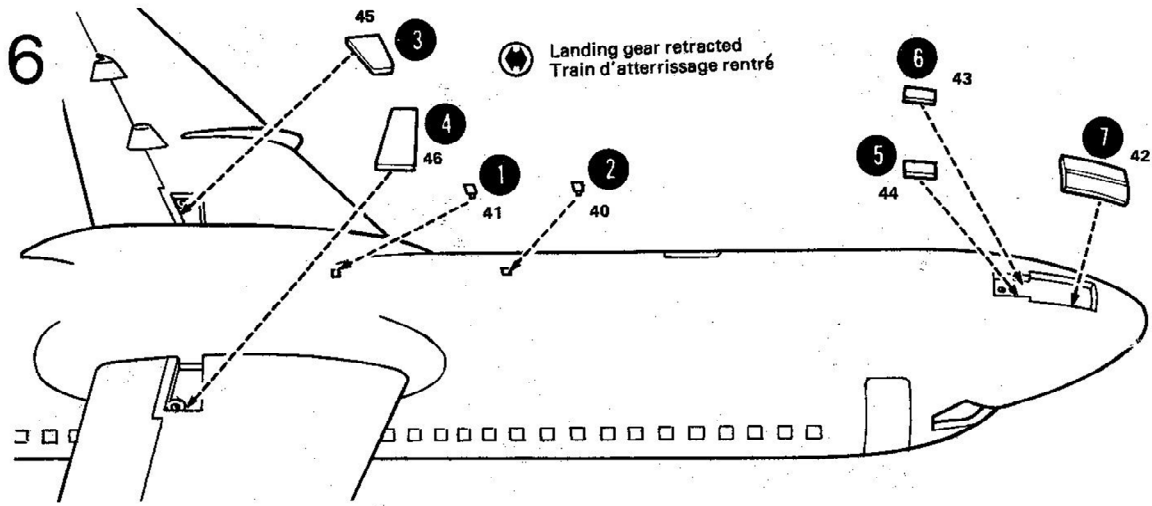

PAINT SCHEME

- A FLAT BLACK/NOIR MATE
- B WHITE/BLANCHE
- C SILVER/ARGENT
- D GRAY/GRIS

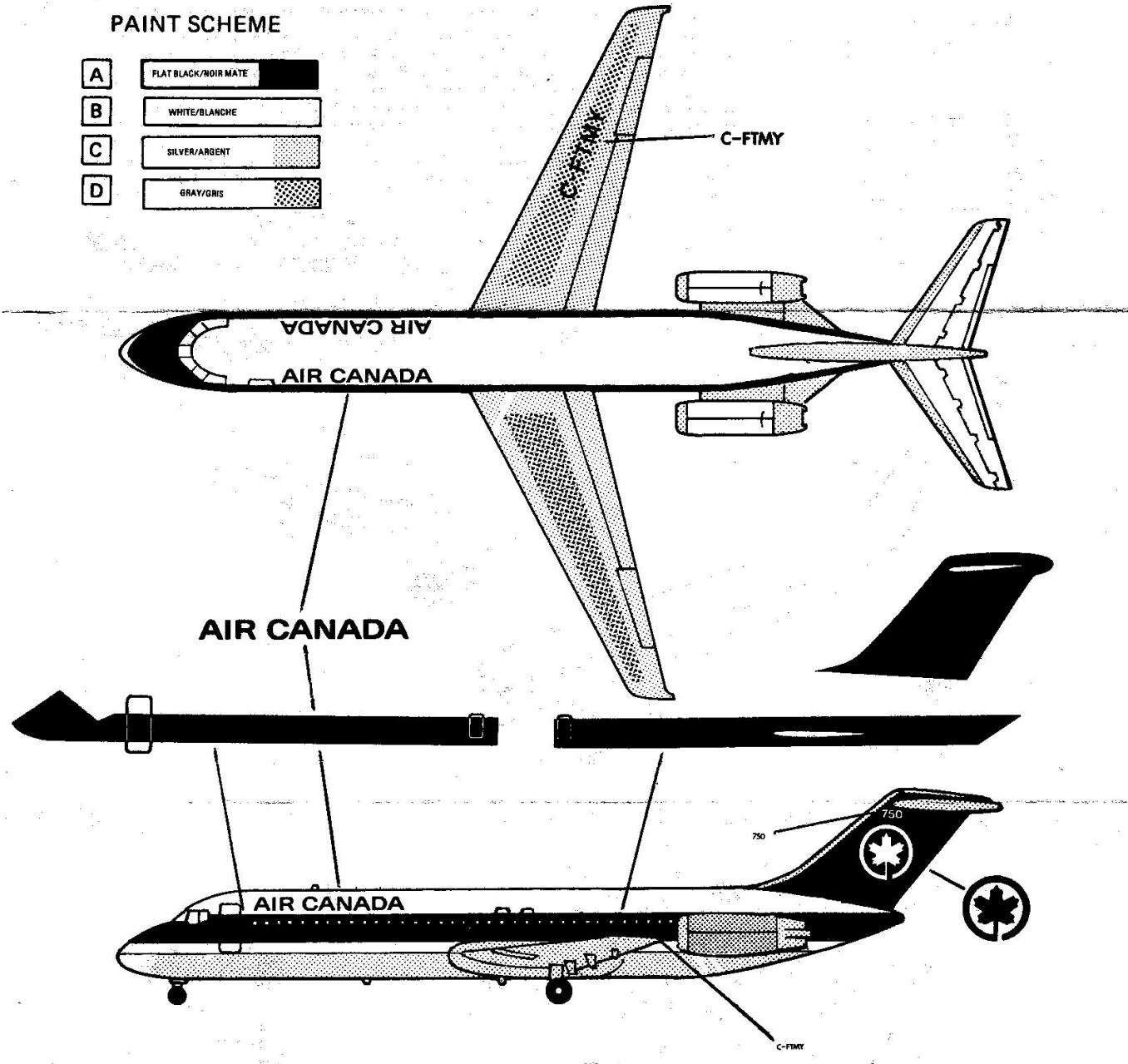

C-FTMY

C-FTMY

C-FTMY

C-FTMY

750

750

C-FTMN

C-FTMN

C-FTMN

C-FTMN

771

771

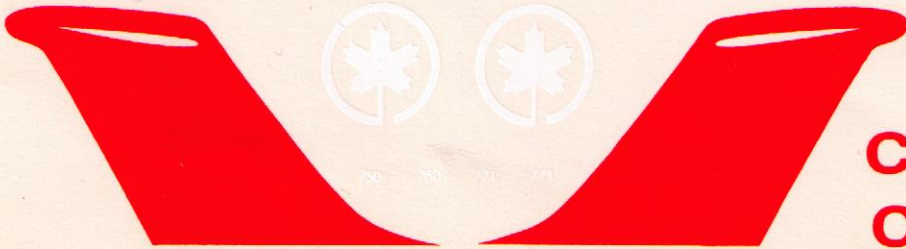
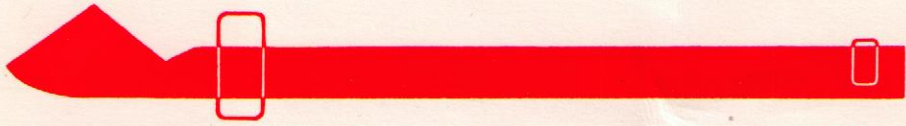

750 750 771 771

AIR CANADA
AIR CANADA

CARGO
CARGO