

## TBF-1



Designed as a replacement for the Douglas TBD Devastator, the prototype XTBF-1 flew on 7 August 1941. Production started soon after and the aircraft redesignated TBF-1. General Motors built the TBM version although it was the same aircraft. The Avenger was the heaviest single engine aircraft of WWII. It used the Grumman 'Sto-wing' wing-fold system to maximize storage space on carriers. The TBF was powered by a Wright R-2600-20 Twin-Cyclone 14 cylinder engine producing 1900hp (1420kw) and had a 3 man crew: pilot, radioman/bombardier/ventral gunner, and turret gunner. Initially the TBF had a nose mounted 0.30 (7.62mm) MG, a single 0.50 (12.7mm) MG in the electrically driven rear turret, and a ventrally mounted 0.30 (7.62mm) MG operated by the radioman/bombardier. The nose mounted gun was replaced by a single 0.50 (12.7mm)MG in each wing (TBF-1c) The large bomb-bay could hold a Bliss-Leavitt Mk 13 torpedo, a single 2000lb (907kg) bomb, or up to 4 x 500lb (227kg) bombs.

The first 100 TBF arrived at Pearl Harbour in June 1942, a few hours after their carrier had departed, so most missing the battle of Midway. 6 Avengers did take part, only one returning to base, damaged, with wounded pilot and radioman. The turret gunner killed in the action. Although unsuccessful, the battle did set the stage for dive-bombers a few hours later when 4 Japanese carriers were hit. Later, TBFs were able to play vital roles in battle due to increasing air superiority over the Japanese. In August 1942, the major battle was in the East Solomons and TBFs were able to sink the Japanese light carrier Ryuro and a dive-bomber, but at the expense of 7 aircraft. The first major prize for the TBF was the Naval Battle of Guadalcanal in November 1942 when Marine Corps and U.S. Navy Avengers helped sink the battleship Hiei. After the Marianas 'Turkey Shoot' a large force of Hellcats, Avengers, and dive-bombers hunted Japanese ships. Although taking heavy losses, Avengers from the carrier USS Belleau Wood sank the light carrier Hiyo. Avengers were also used during the sinking of the Super Battleships Musashi and Yamato. RNZAF Avengers based on South Pacific islands also supported operations in the Pacific during the Bougainville campaign. As well as surface targets, Avengers also hit Pacific submarine traffic and submarine transport between Japan and German occupied Europe.

The Avenger was let down by unreliable American torpedos and lack of air support and protection from Japanese fighters.

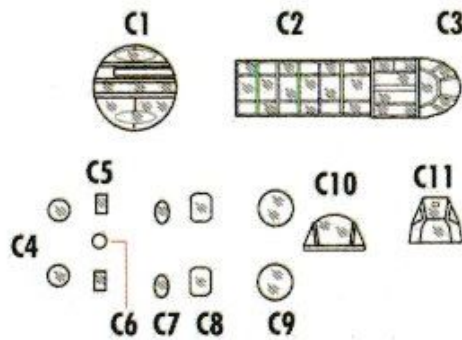
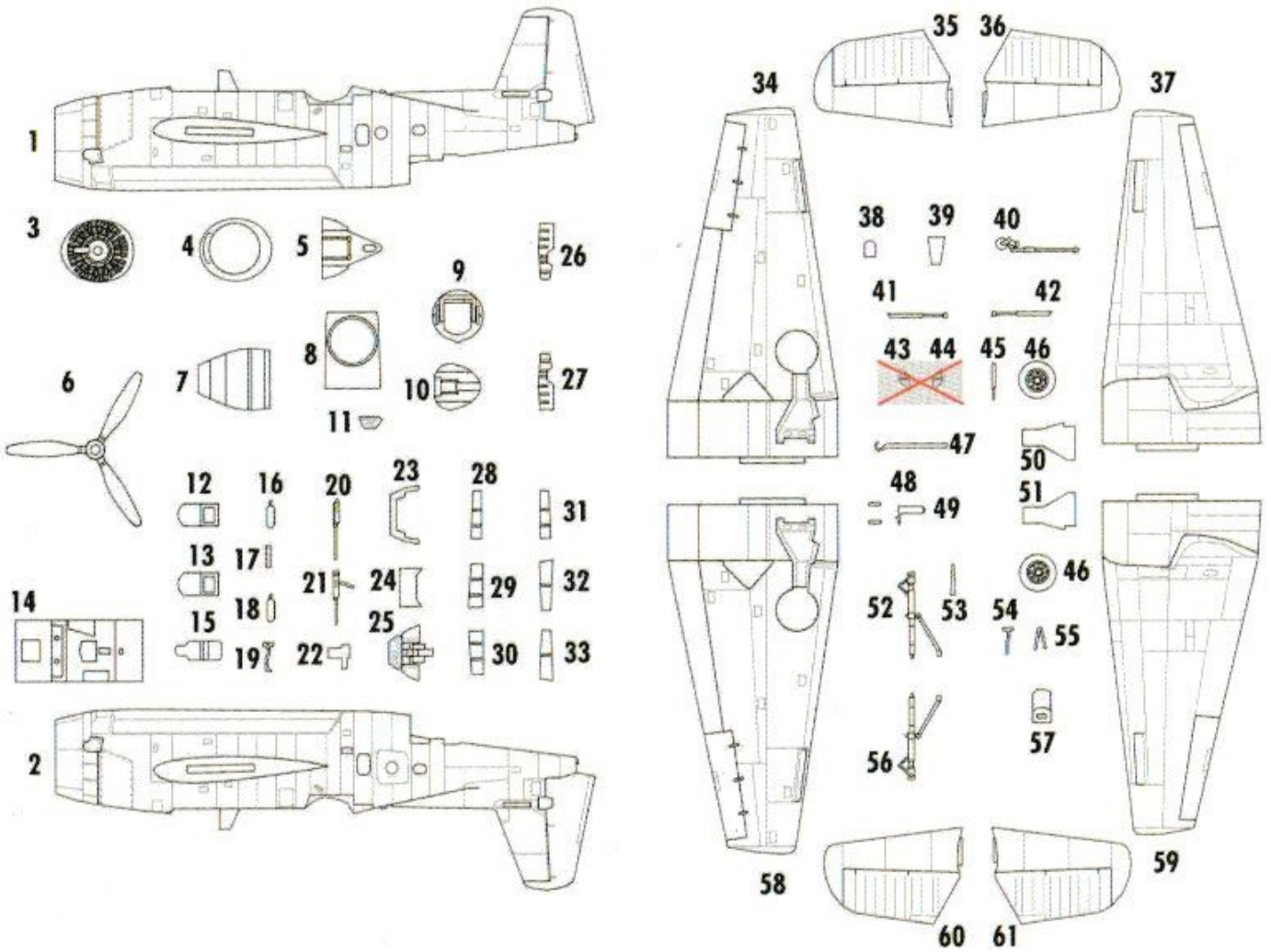

REMOVE



BEND



OPEN HOLE



SCRATCH BUILD



COLOR



SYMETRICAL ASSEMBLY



OPTION



SECOND GLUE



White



Light Grey



Exhaust



Tyres Black



Black



Bronze Green



Silver



Yellow



Chrome



Interior Green



Leather



Engine Grey

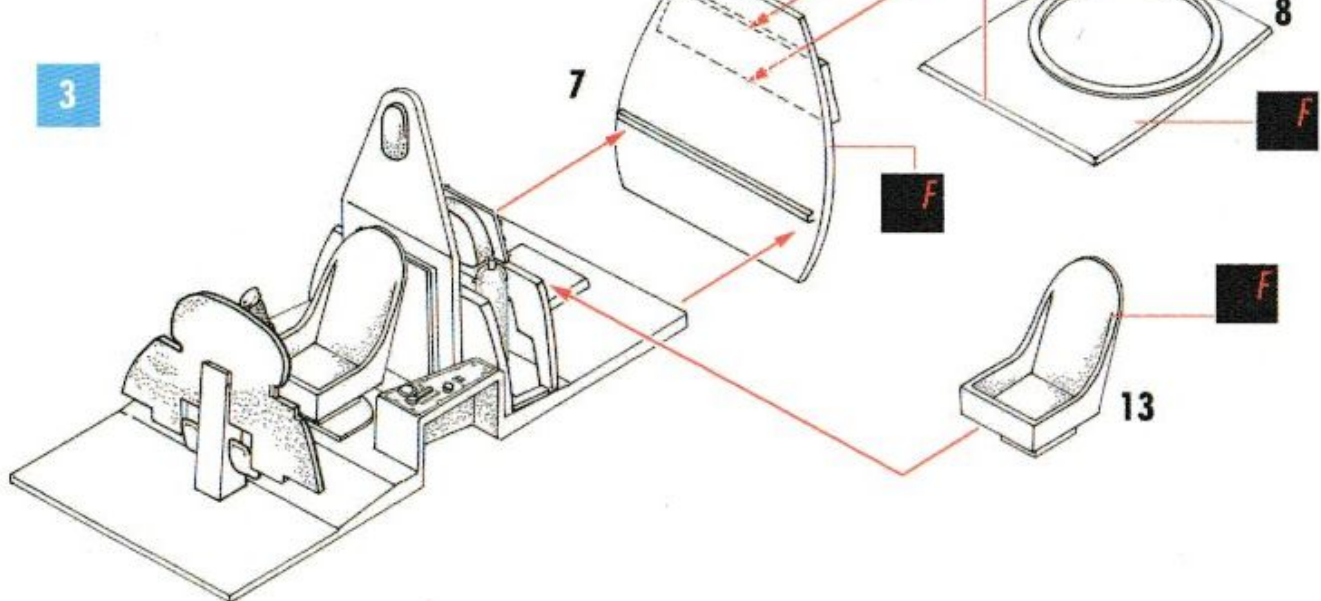
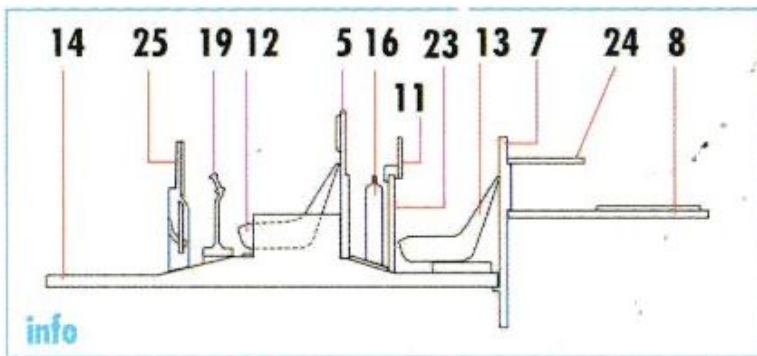
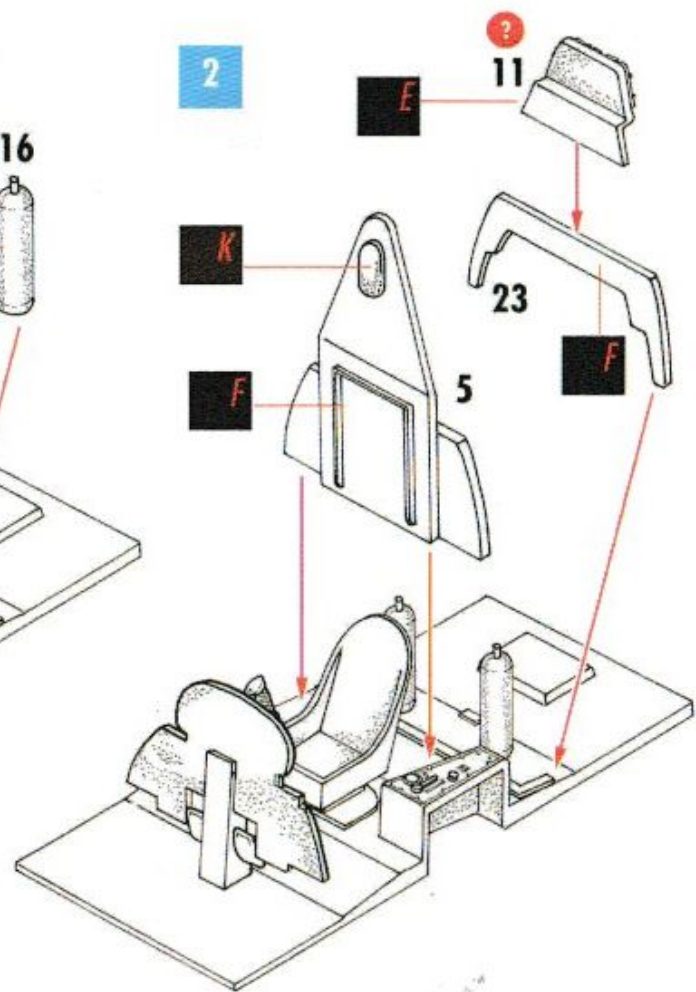
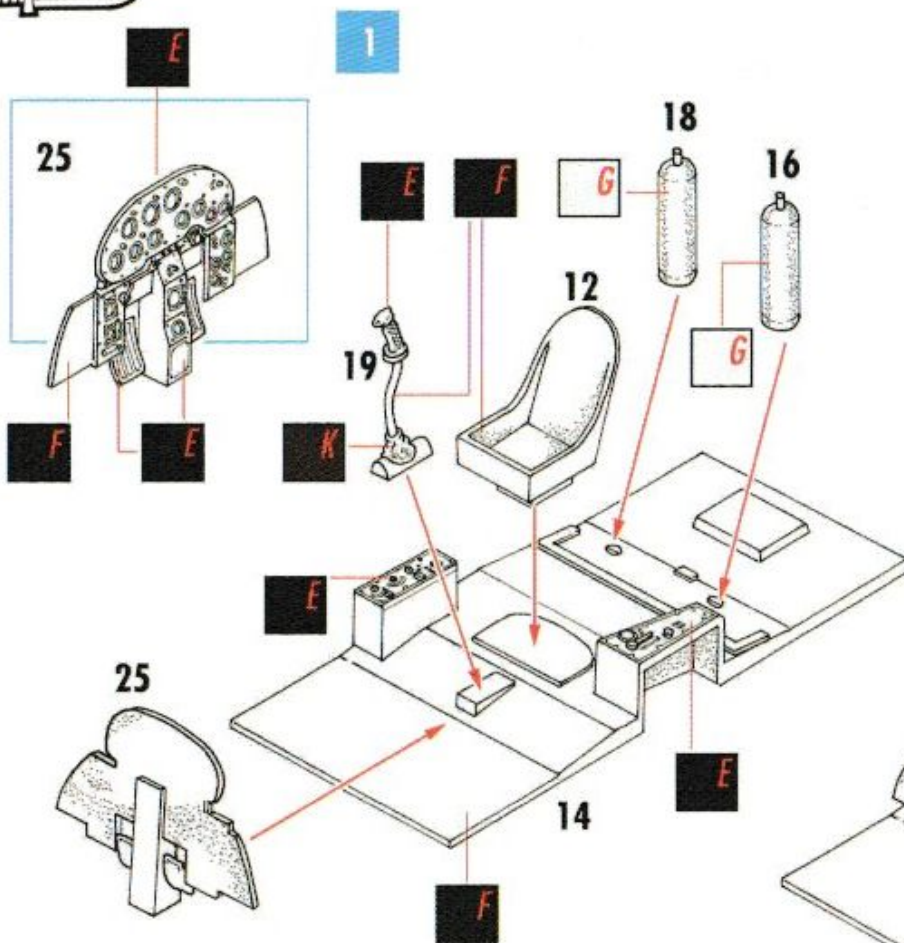

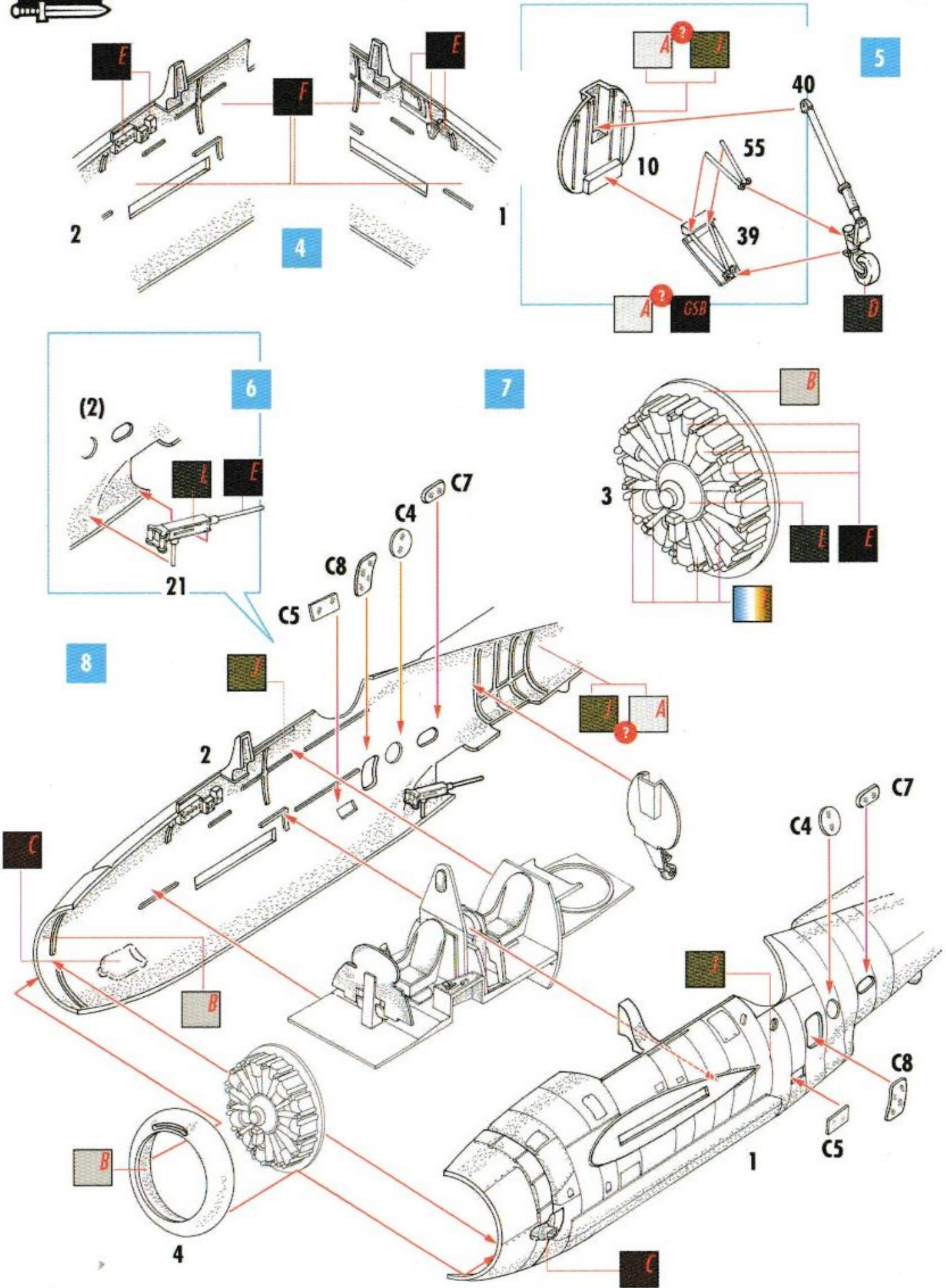

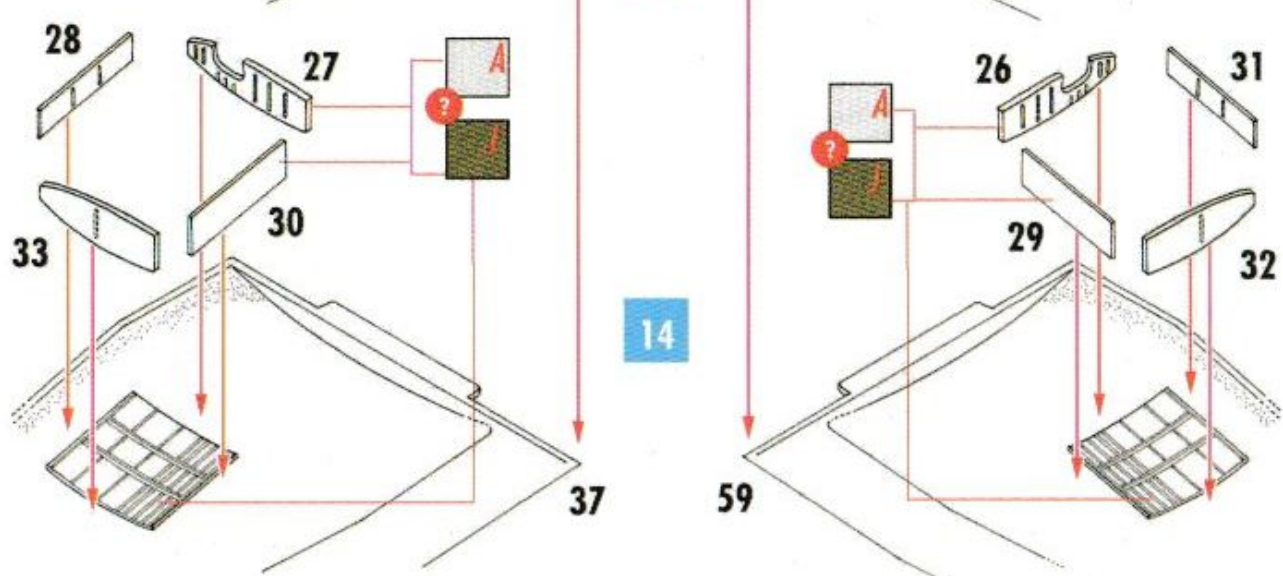
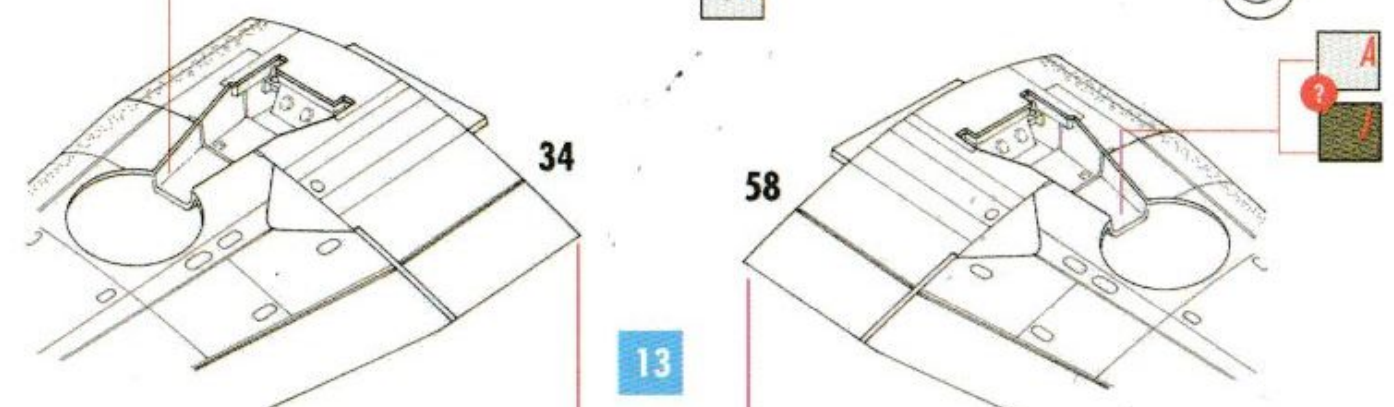
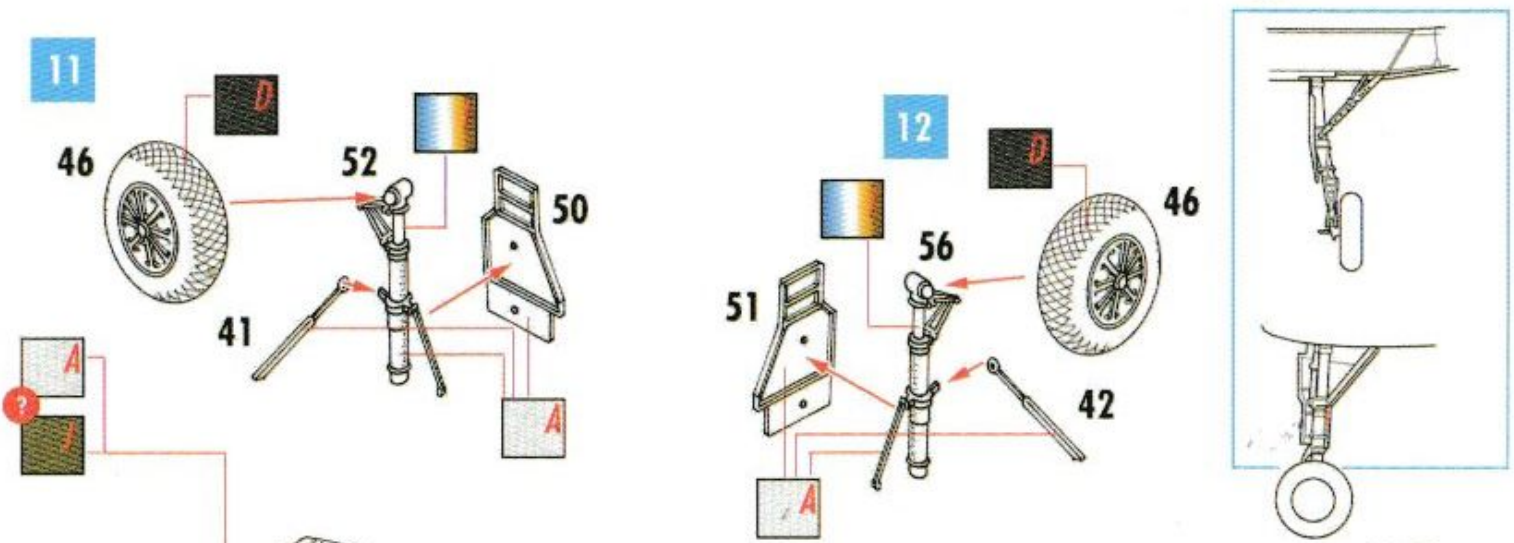
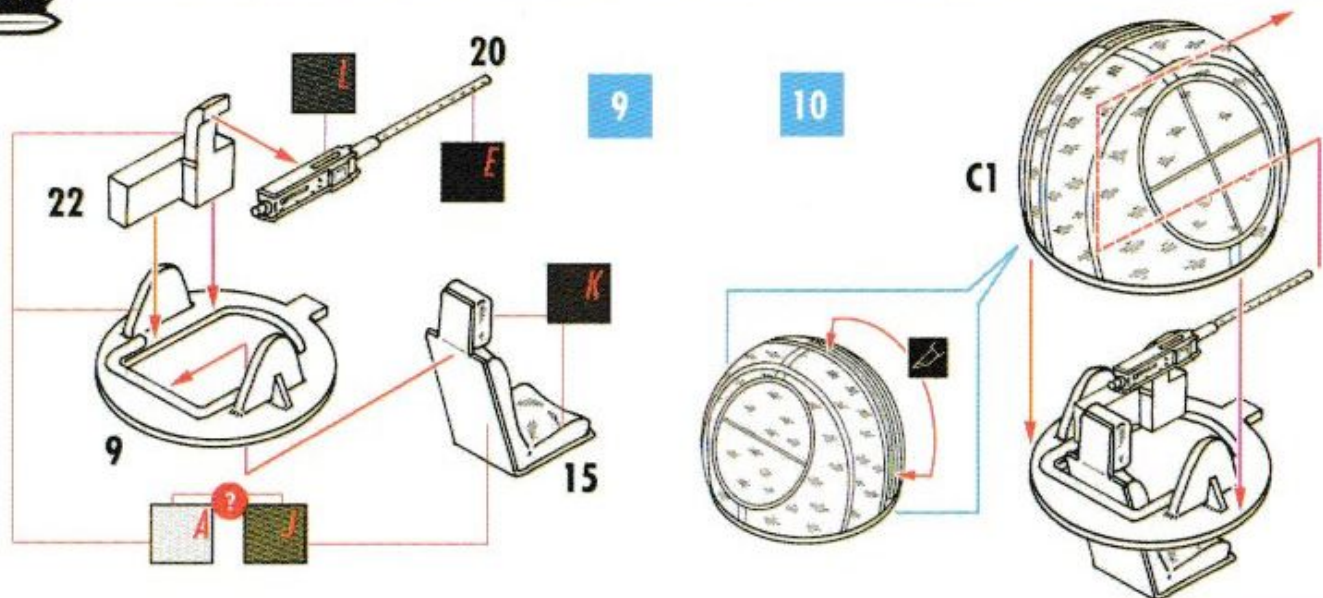

15

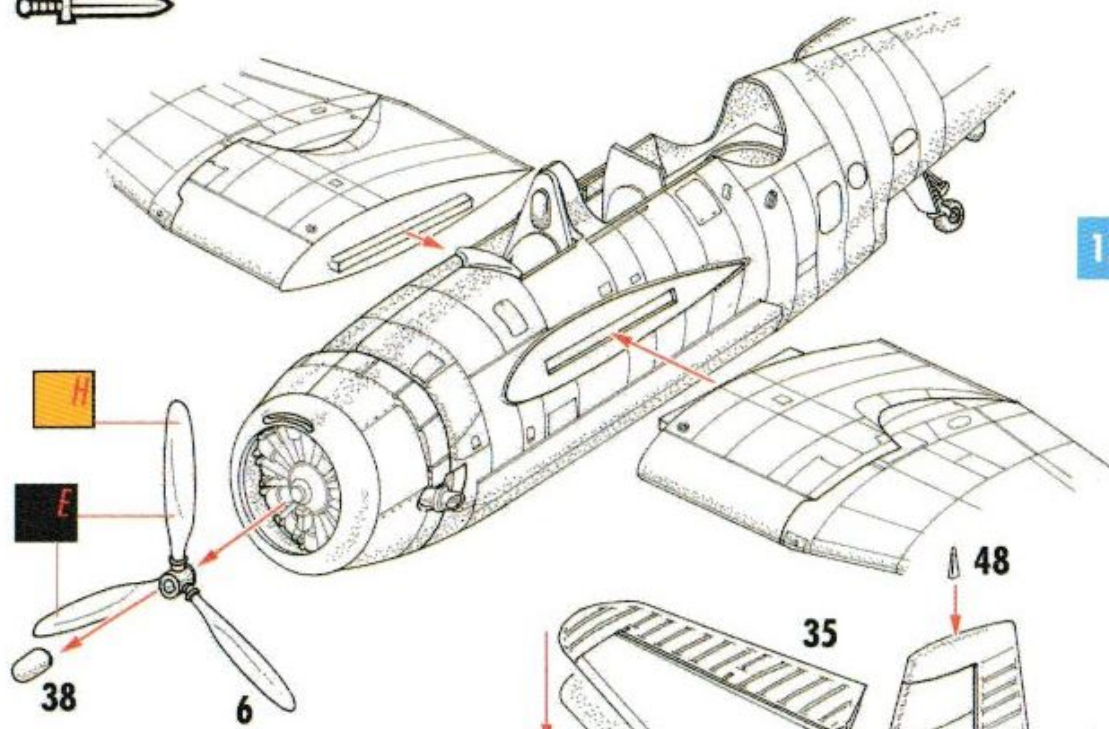

16

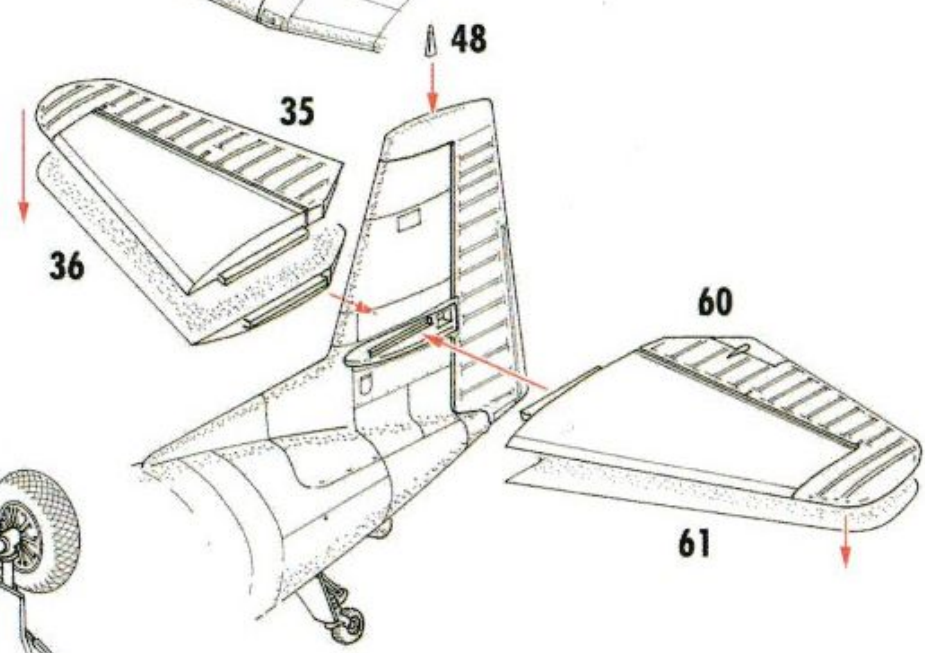

17

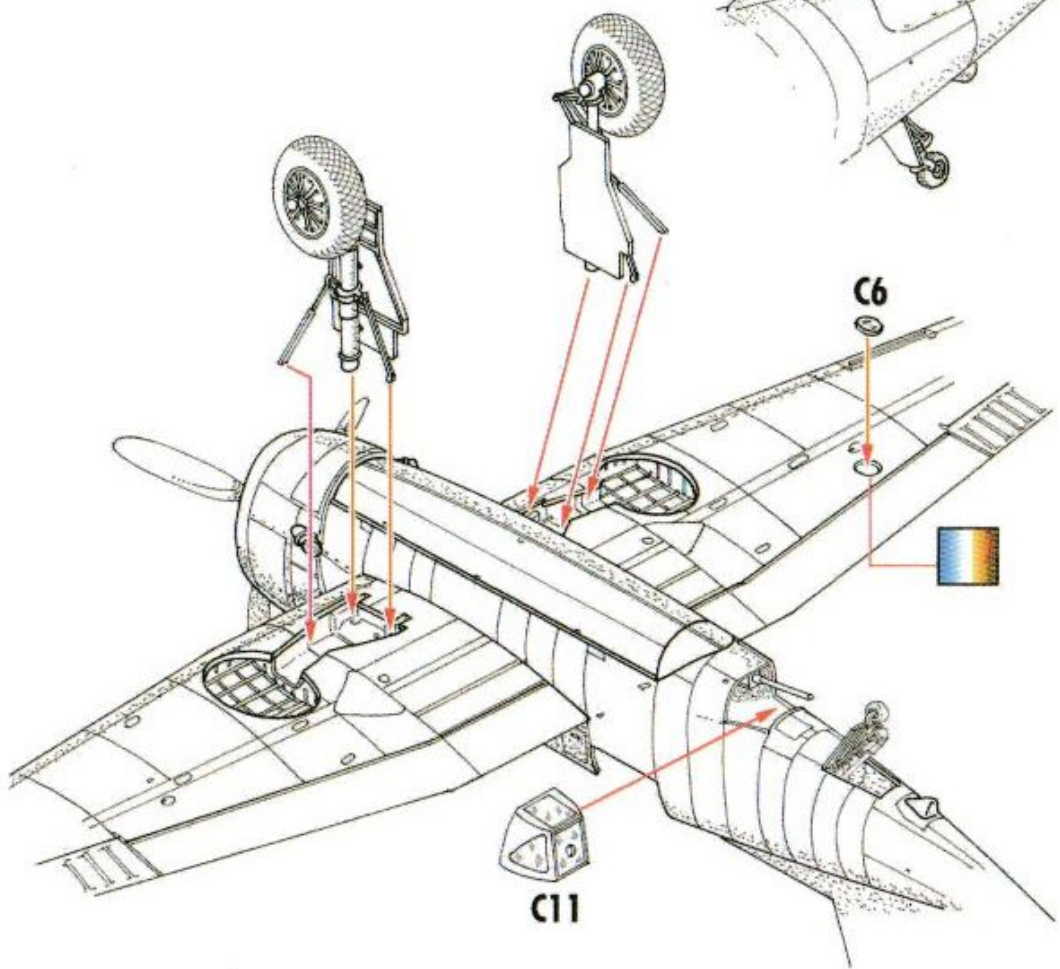

18

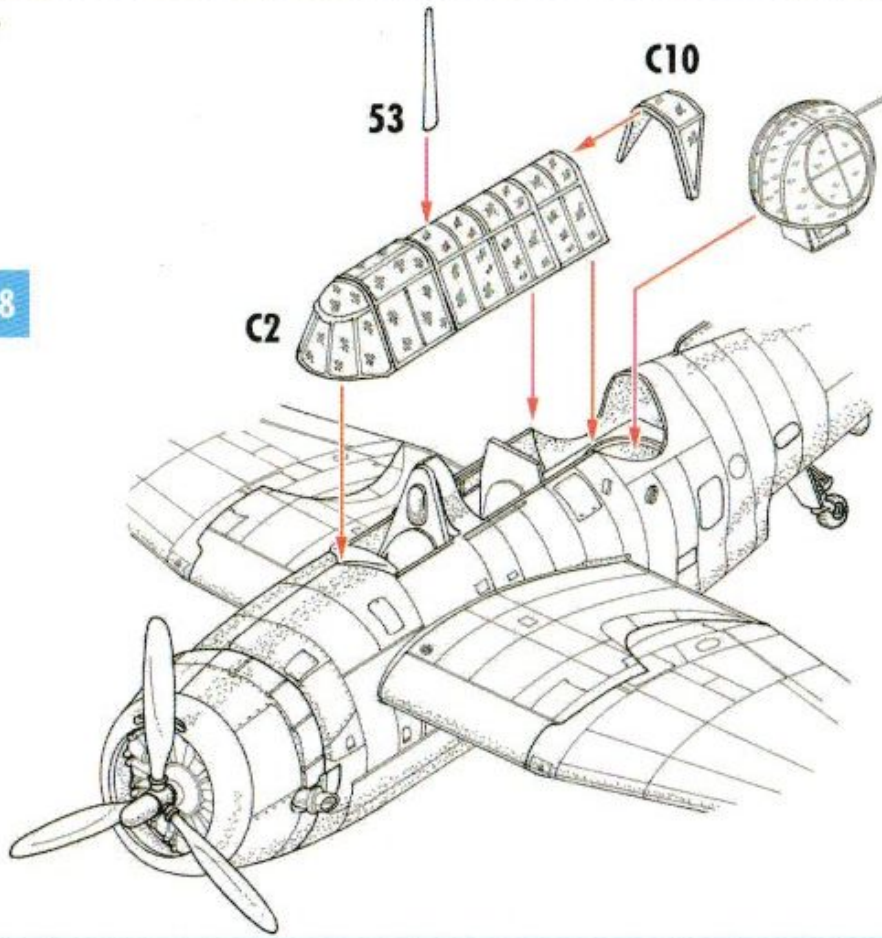

Stencil data

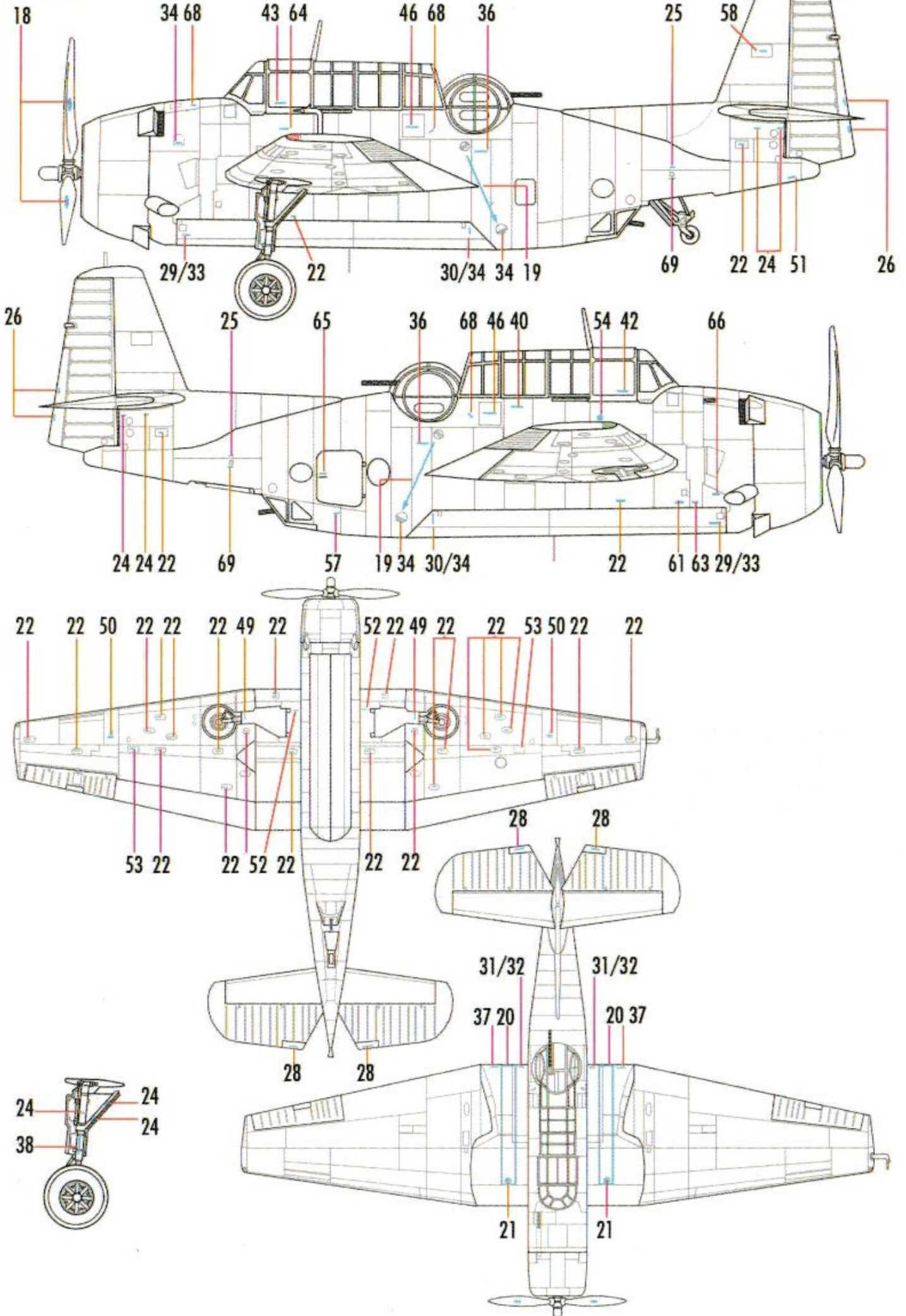



TBF-1, US NAVY, VT-8, CV-3 USS Saratoga, 1942

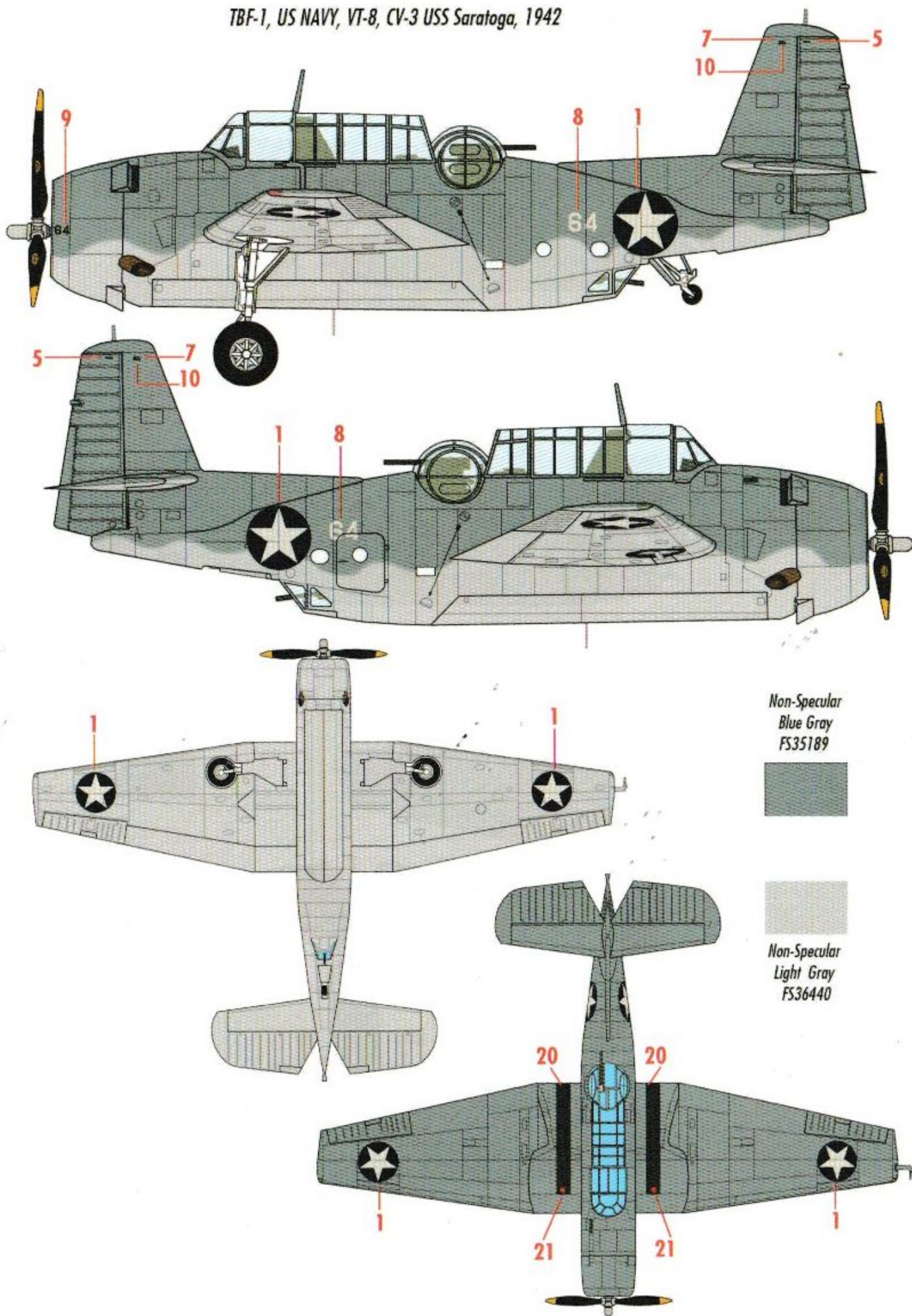

TBF-1 Avenger of Marine Sq.  
VMSB-131 at Guadalcanal 1942

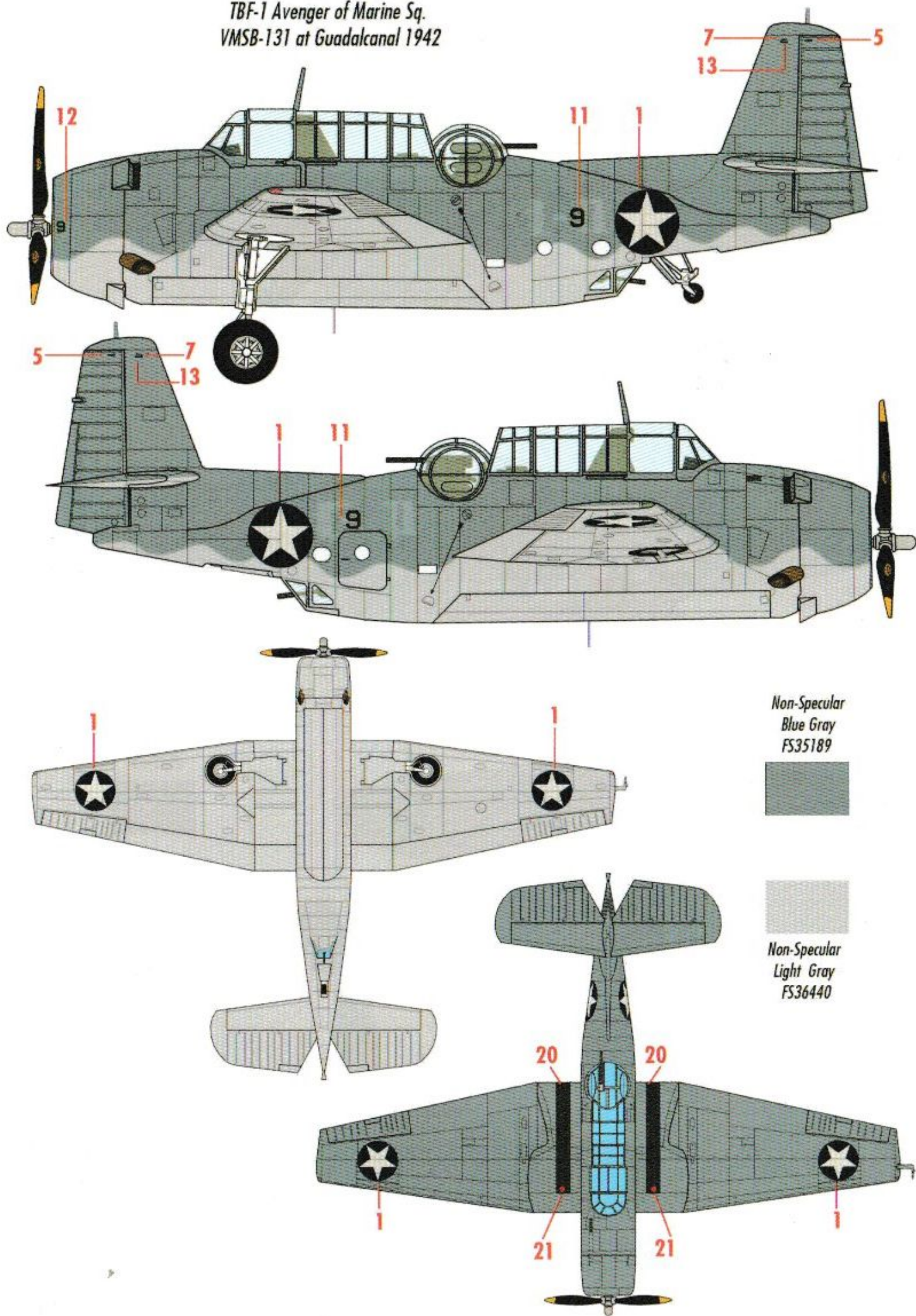

TBF-1, Bu.No.00380, US NAVY, Ens. A.K.Ernest, AMM3c. J.D.Manning, ARM H.Ferrier, VT-8 Battle of Midway, 4 June 1942. Six VT-8 Avengers attacked the Japanese carriers, one survived

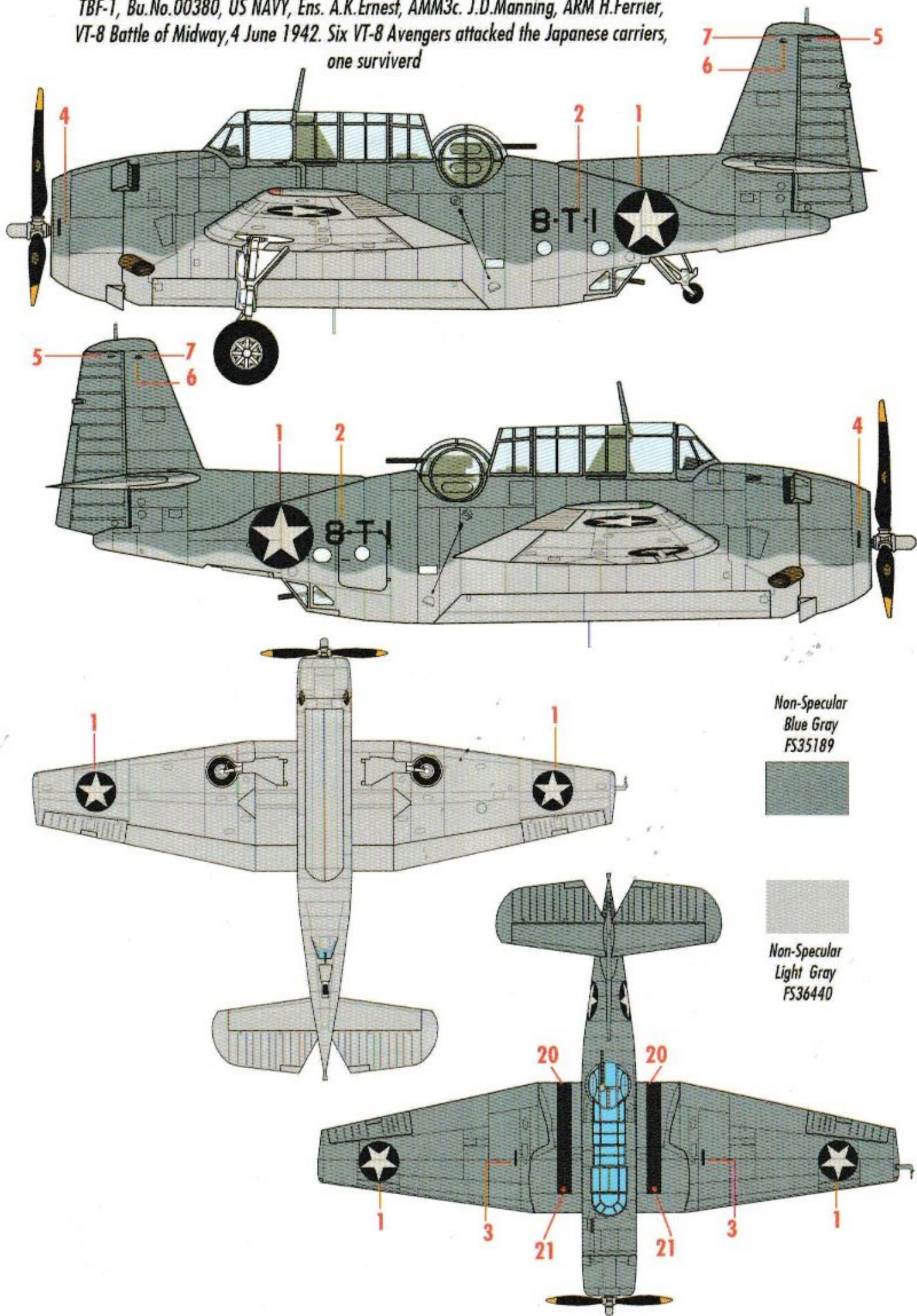



SWORDMODELS s.r.o. Těšínská 288  
739 34 Šenov  
CZECH REPUBLIC

www.swordmodels.cz  
e-mail: swordmodels@gmail.com



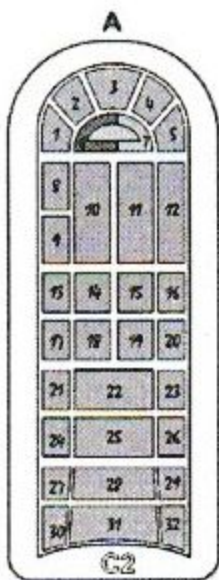
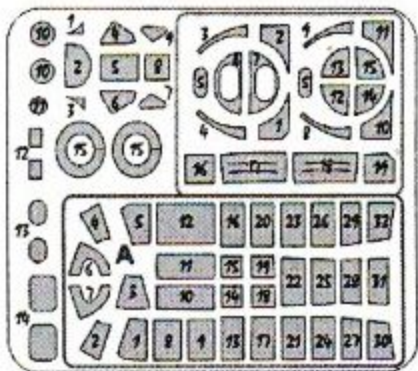

 Liquid mask