

Heller

CITROËN 2 CV CHARLESTON & DOLLY

80766



FrANÇAis

La 2 CV est présentée pour la première fois au salon de 1948, douze ans après le début des études. Cette voiture fut lancée par le directeur de Citroën M. Boulanger, voulant cette surprenante auto. Il en avait dressé personnellement les grandes lignes dès 1936 qu'il résumait ainsi : "quatre roues sous un parapluie" et il ajoutait : "il faut que la nouvelle voiture, chargée d'oeufs, puisse traverser un champ... sans en casser un seul". Du moins, est-ce ainsi que veut la légende... Cette voiture à silhouette ingrate ne provient pas d'un bureau de style de renom, c'est le résultat froid et logique d'une étude d'ingénieurs. Pourtant la 2 CV ne tardera pas à donner la preuve de ses possibilités insoupçonnées. A tel point que les délais de livraison grimperent jusqu'à six ans en 1950. De modification en modification, la 2 CV évoluera sans rien perdre de son caractère, même quand elle adopte des couleurs plus gaies mais plus salissantes que son gris métallisé d'origine. Elle demeure toujours aussi pratique, et cette voiture à vocation rurale connaîtra bientôt parmi la clientèle urbaine un succès auquel on ne s'attendait pas chez Citroën. Au fil des ans, la 2 CV vit sa puissance et ses performances augmenter d'une façon appréciable, gardant toujours sur tous les revêtements et par tous les temps, sa stupéfiante tenue de route. Si l'on admet que d'importantes modifications ont eu lieu, et qu'il n'y a aucune pièce commune entre une 2 CV de 1948 et un modèle 1990, il faut bien reconnaître que le moteur est bien le seul dont on ait jamais pu doubler le régime de rotation et tripler la puissance sans nuire à sa longévité.

Longueur	3,83 m
Largeur	1,48 m
Hauteur à vide	1,6 m
Moteur	puissance fiscale 3 CV <p>Nombre de cylindres: 2</p> <p>Refroidissement par air</p>
4 roues indépendantes	
Poids total en charge	895 kg

Deutsch

Der 2 CV wurde 1948 zum ersten Mal beim Automobilsalon vorgestellt, zwölf Jahre nach Beginn der Studien. Dieses Auto wurde vom Citroën Direktor Herrn Boulanger initiiert, der dieses besondere Auto haben wollte. Er selbst hatte schon 1936 die groben Linien umrissen, mit den Worten: "Vier Räder unter einem Regenschirm" und er fügte hinzu: "Das neue Auto muss, mit Eiern beladen, ein Feld durchqueren können, ohne dass ein einziges Ei dabei kaputtgeht". So überliefert es jedenfalls die Legende... Der Wagen mit der reizlosen Silhouette stammte nicht aus einem namhaften Designerbüro, sondern ist das kalte und logische Ergebnis einer Designstudie von Ingenieuren. Der 2 CV bewies jedoch in kürzester Zeit seine ungeahnten Fähigkeiten und zwar so sehr, dass die Lieferzeiten 1950 auf 6 Jahre stiegen. Der 2 CV durchlief viele Modifikationsstufen, ohne seinen Charakter zu verlieren, selbst als er Farben annahm, die heller und farbenfroher waren als sein ursprüngliches Metallgrau. Er blieb immer noch genauso praktisch und dieses "ländliche" Fahrzeug erlangte bald einen Erfolg bei der städtischen Kundschaft, den Citroën nie erwartet hatte. Im Laufe der Jahre wurden die Kraft, Leistung und Performance des 2 CV erheblich gesteigert, aber er behielt seine ungläubliche Straßenlage auf allen Untergründen und bei jeder Witterung. Obwohl umfangreiche Modifikationen vorgenommen wurden und keine der Teile des 1948er Modells 2 CV im 1990er Modell zu finden sind, kann man nicht leugnen, dass der Motor der einzige ist, bei dem es möglich war, die maximale Drehzahl zu verdoppeln und die Leistung zu verdreifachen, ohne die Lebensdauer zu beeinträchtigen.

Länge	3,83 m
Breite	1,48 m
Höhe (leer)	1,60 m
Motor	Nennleistung 3 CV (29PS) <p>Anzahl der Zylinder: 2</p> <p>Luftkühlung</p>
4 unabhängige Räder	
Zulässiges Gewicht	895 kg

Italiano

La 2 CV viene presentata per la prima volta al salone del 1948, dodici anni dopo l'inizio degli studi. Fu lo stesso direttore della Citroën, Boulanger, che l'aveva voluta, a lanciare quest'automobile sorprendente. Egli ne aveva personalmente disegnato le grandi linee fin dal 1936, riassumendole così: "quattro ruote sotto un ombrello" ed aggiungendo: "occorre fare in modo che questa nuova vettura, carica di uova, possa attraversare un campo ... senza romperne nemmeno uno". Così almeno dice la leggenda ... Quest'auto dalla silhouette ingrata non uscì da un famoso laboratorio di stile, ma è il risultato freddo e logico di uno studio di ingegneri. Eppure la 2 CV non tarderà a dimostrare le proprie insospettabili possibilità. A tal punto che i termini di consegna slittarono fino a 6 anni nel 1950. Di modifica in modifica la 2 CV evolve senza nulla perdere del suo carattere, neppure quando adotta colori più allegri ma più delicati rispetto all'originale grigio metallizzato. Autovettura a vocazione rurale, rimane sempre molto pratica anche quando incontrerà fra la clientela urbana un successo che alla Citroën nessuno si aspettava. Con gli anni, potenza e prestazioni aumentano, ma la 2 CV mantiene sempre su tutti i terreni e in ogni tempo una stupefacente tenuta di strada. Pur ammettendo che ci siano state grosse modifiche tanto che un modello del 1948 e uno del 1990 non hanno nessun pezzo in comune, bisogna riconoscere che il motore è l'unico al quale non dia stato possibile raddoppiare il regime di rotazione o triplicare la potenza senza nuocere alla longevità.

Lunghezza	3,83 m
Larghezza	1,48 m
Mezza a vuoto	1,6 m
Motore	potenza fiscale 3 CV <p>Numero di cilindri: 2</p> <p>Raffreddamento ad aria</p>
4 ruote indipendenti	
Peso totale	895 kg a pieno carico

English

The 2 CV was presented for the first time at the 1948 motor show, 12 years after the start of the design study. It was launched by the Citroën Director, Mr. Boulanger, who had always wanted this remarkable vehicle. He had personally laid down the broad lines in 1936, describing them thus: "four wheels under an umbrella", and adding that the new car "should be able to cross a field full of eggs without breaking one". At least this is what the legend says... This ugly shaped car was not the work of a famous stylist; it was the cold and logical result of a design study by engineers. Nevertheless the 2 CV quickly demonstrated its unexpected capabilities: to such an extent that the delivery delays continued to grow, and reached 6 years in 1950. The 2 CV evolved through many stages of modification, without losing its character, even when it adopted colors which were brighter but more delicate than its original metal grey. It still remained just as practical, and this "rural" vehicle soon obtained a degree of success with the urban clientele which had never been expected by Citroën. Over the years, the power and performance of the 2 CV were increased considerably, but it still retained its unbelievable road holding on all surfaces and in all weathers. Although major modifications have taken place and none of the parts of the 1948 model 2 CV can be found in the 1990 model, it cannot be denied that the engine is the only one of which it has been possible to double the maximum RPM and triple the power output without adversely affecting its durability.

Length	3.83 m
Width	1.48 m
Height (unladed)	1.6 m
Engine	rated horsepower 3 CV <p>Number of cylinders: 2</p> <p>Air cooling</p>
4 wheel independent suspension	
Gross vehicle weight	895 kg

Español















El 2 CV se presentó por primera vez en el salón de t 948, doce años después del principio de sus estudios. Este coche fue lanzado por el director de Citroën, el Sr Boulanger, que deseaba este sorprendente auto-móvil. Fue él mismo quien había trazado personalmente en 1936, a grandes líneas, como debía ser este automóvil, que él describía así: "ce cuatro ruedas bajo un paraguas", añadiendo "es necesario que este nuevo coche, cargado de huevos, pueda atravesar un campo... sin romper ni uno". Por los menos eso es lo que dice la leyenda... Este coche, de silueta poco elegante, no salió de una oficina de proyectos presti-giosa, sino que fue el resultado frío y lógico de un equipo de ingenieros. Y sin embargo el 2 CV no tardará en dar la prueba de sus posibilidades insospechadas: hasta tal punto que los plazos de entrega se alarga-rán hasta 6 años en 1950. De una modificación a otra, el 2CV evolucionará sin perder nada de su carácter, incluso cuando adopte unos colores más alegres, aunque menos sufridos, que su color inicial gris metálico. Pero seguirá siendo siempre tan práctico, y este coche, de vocación rural, conocerá pronto entre la clientela urbana un éxito inesperado para la casa Citroën. Con el paso de los años, el 2 CV aumentó su potencia y sus prestaciones de manera apreciable, conservando siempre sobre todo tipo de revestimiento y cualesquiera que sean las condiciones atmosféricas una adherencia extraordinaria. Aun cuando se admite que ha sufrido desde entonces notables modificaciones y que no hay ninguna pieza común entre el 2 CV de 1948 y un modelo de 1990, hay que reconocer sin embargo que el motor es el único cuyo índice de rotación ha podido ser doblado y su potencia triplicada sin perjuicio de su longevidad.

Longitud	3,83 m
Anchura	1,48 m
Altura en vacío	1,6 m
Motor	potencia fiscal 3 CV <p>Número de cilindros: 2</p> <p>Refrigeración por aire</p>
4 ruedas independientes	
Peso total de carga	895 kg

Nederlands

De 2 CV is voor de eerste keer te zien geweest op da automobieltentoonstelling van 1948, twaaft jaar nadat met de studies begonnen was. De auto werd gelanceerd door de heer Boulanger, directeur van Citroën, die dat verbazingwekkende voertuig absoluut wilde. Al vanaf 1936 had hij persoonlijk de grote lijnen ervan ontworpen die hij aldus samenvatte. "vier wielen onder een paraplu" en hij voegde er aan toe "dat nieuwe voertuig dient, met een lading eieren, door een weiland ta kunnen rijden... zonder dat er een breekt". Althans, dat wil de legende. Dat voertuig met zijn lelijk uiterlijk kwam niet uit een bekendstaand vormgevingsbureau maar was het koele en logische resultaat van een studie van ingenieurs. En toch zal de 2 CV in korte tijd het bewijs lavenen van zijn onvermoede mogelijkheden. En dat gaat zover dat in 1950 de leveringstermijnen oplopen tot zes jaar. Ondanks alle wijzigingen zal de 2 CV zich ontwikkelen zonder zijn karakter ta verliezen, zelfs ais de kleuren ervan vrolijker maar meer vuil aantrekkend worden dan de oorspronkelijke grijze metallic kleur. De auto blijft steeds even praktisch en, hoewel in eerste instantie bestemd voor het platteland, zal hij al vlug onder de cliënten uit de steden een succes hebben dat Citroën niet verwachtte. In de loop van de jaren heeft de 2 CV zijn vermogen en prestaties aanzienlijk zien toene-men, maar met behoud van zijn verbazingwekkende wegligging op alk wegdek en bij elk weertype. Hoewel toegegeven dient te worden dat ar belangrijke wijzigingen plaatsgevonden hebben en dat geen enkel onderdeel van een 2 CV van 1948 overeenkomt met een van 1990, dient erkend te worden dat de motor echt de enige is waarvan men ooit de draaisnelheid heeft kunnen verdubbelen en het vermogen verdried-voudigen zonder nadelige invloed op de levensduur.

Langte	3,83 m
Breedte	1,48 m
Hoogte onbelast	1,6 m
Motor	fiscaal vermogen 3 CV <p>Aantal cilinders: 2</p> <p>Luchtkoeling</p>
4 onafhankelijke wielen	
Totaalgewicht belast	895 kg

- | | | | | | | | | |
|--|---|--|--|--|--|---|--|--|
| 
2
Vert brillant
Gloss emerald
Glänzend-Grün | 
5
Gris brillant
Gloss grey
Glänzend-Grau | 
11
Argent
Silver
Silber | 
19
Rouge brillant
Gloss red
Glänzend-Rot | 
20
Bordeaux brillant
Gloss crimson
Glänzend-Karmesinrot | 
21
Noir brillant
Gloss black
Glänzend-Schwarz | 
22
Blanc brillant
Gloss white
Glänzend-Weiss | 
27
Gris mer mat
Matt sea grey
Matt-See grau | 
33
Noir mat
Matt black
Matt-Schwarz |
| 
40
Gris pale brillant
Gloss pale grey
Glänzend-Blassgrau | 
53
Gris métallique
Gunmetal
Metallgrau | 
63
Sable mat
Matt sand
Matt-Sand | 
69
Jaune brillant
Gloss yellow
Glänzend-Gelb | 
127
Gris satiné
Satin grey
Satin-Grau | 
321
Rouge transparent
Clear red
Durchsichtiges Rot | 
322
Orange transparent
Clear orange
Durchsichtiges Orange | | |

a 2CV Charleston rouge Delage

b 2CV Charleston jaune Hélios

c 2CV Charleston gris Cormoran

d 2CV Dolly

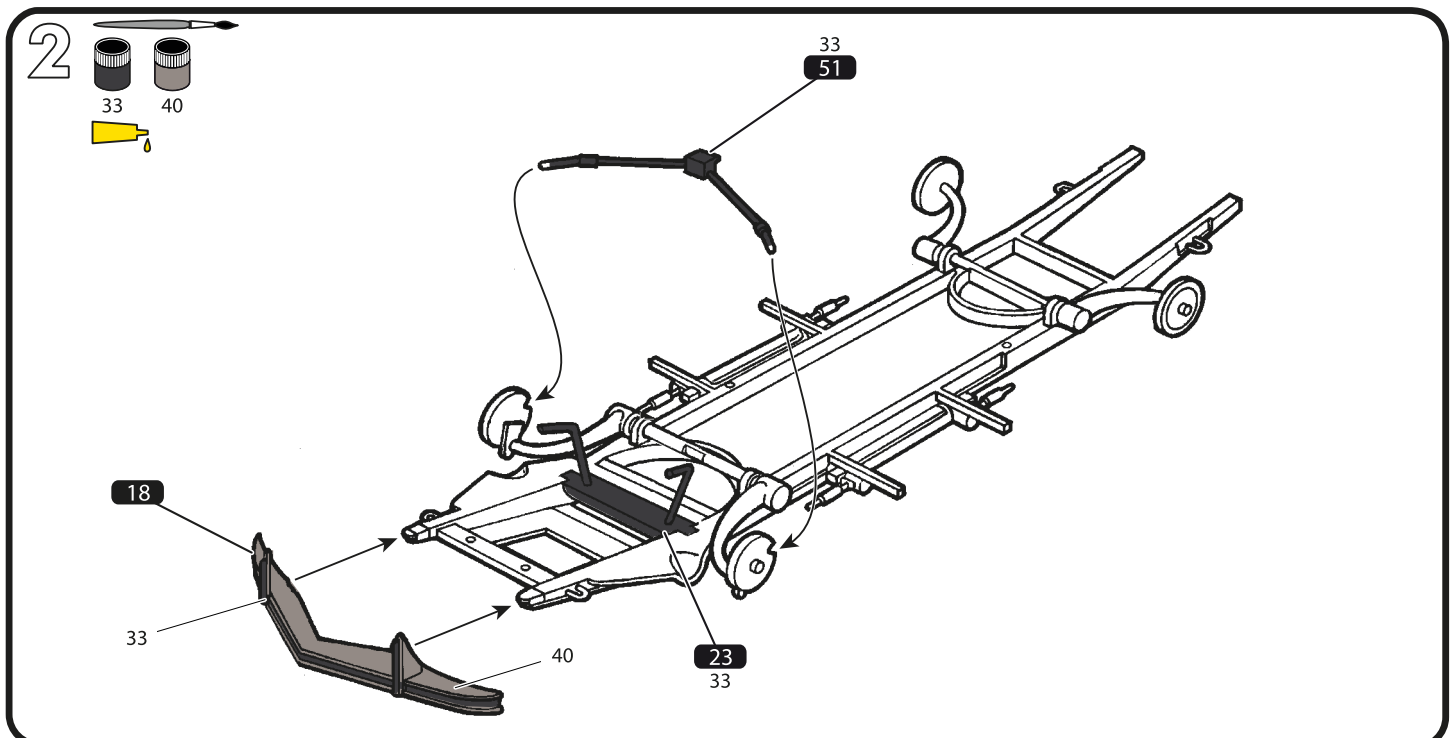
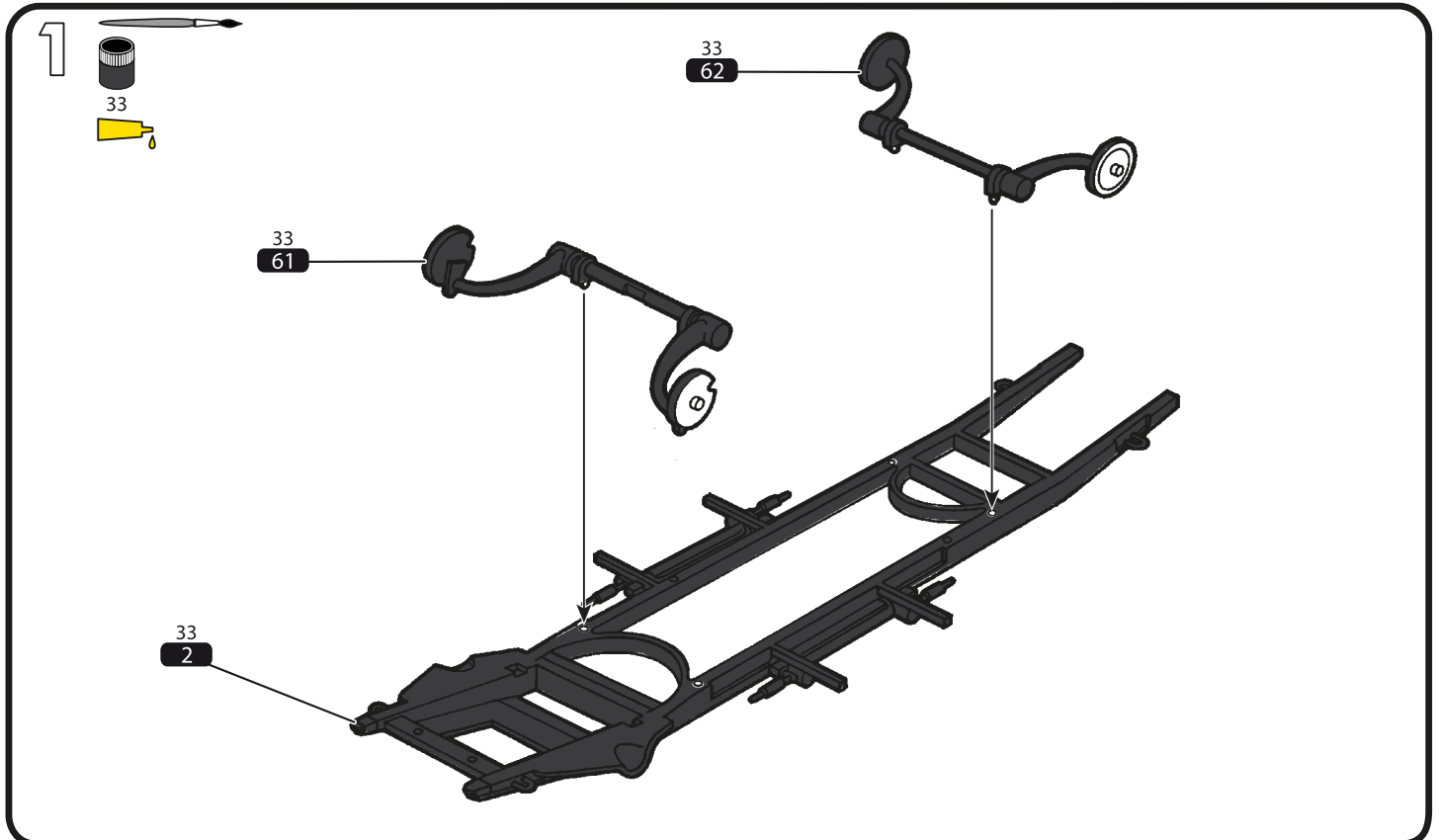

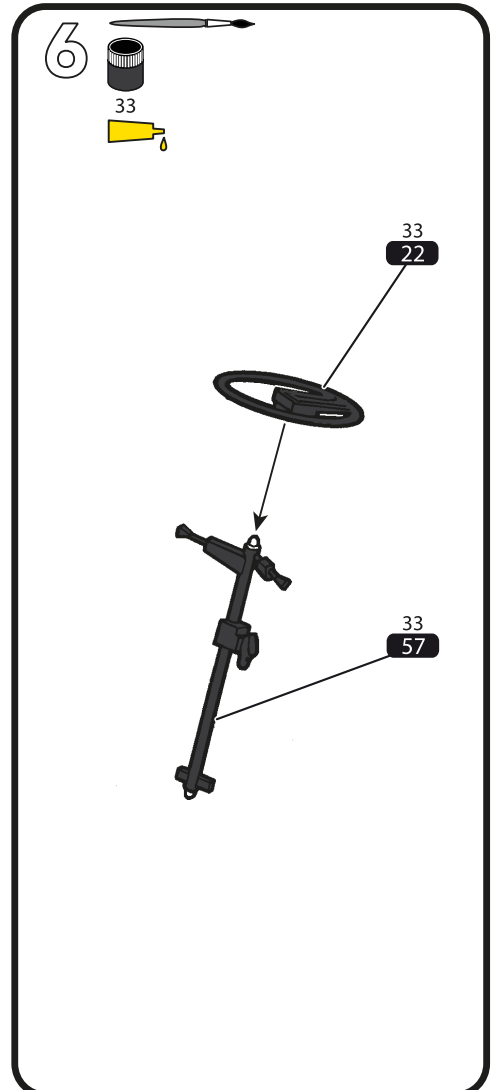
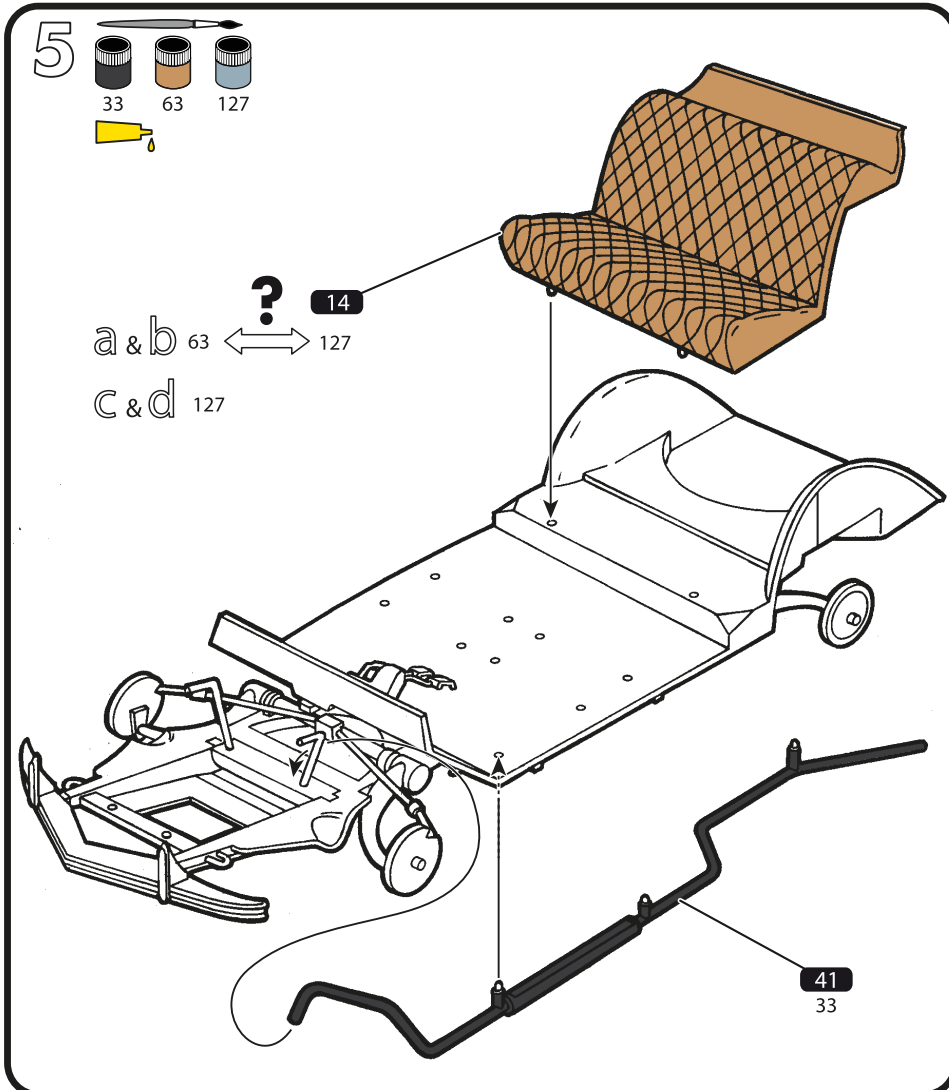
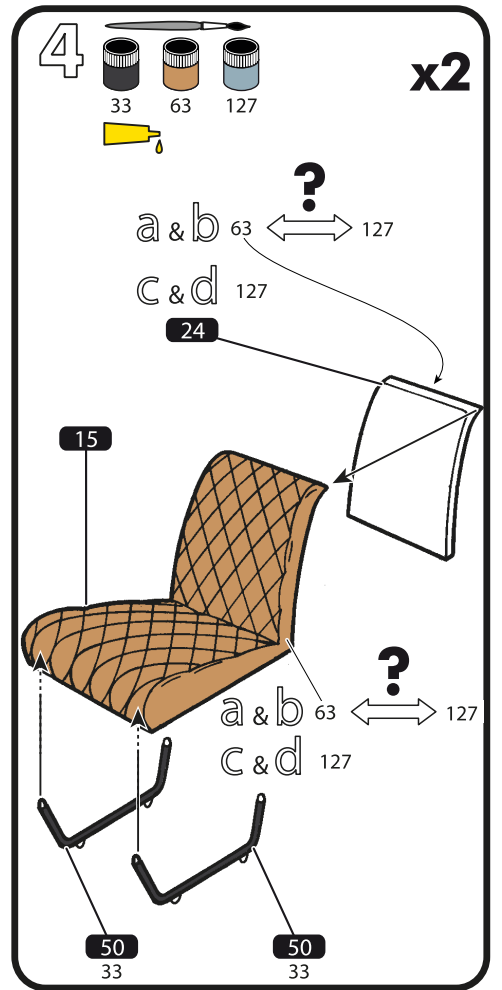
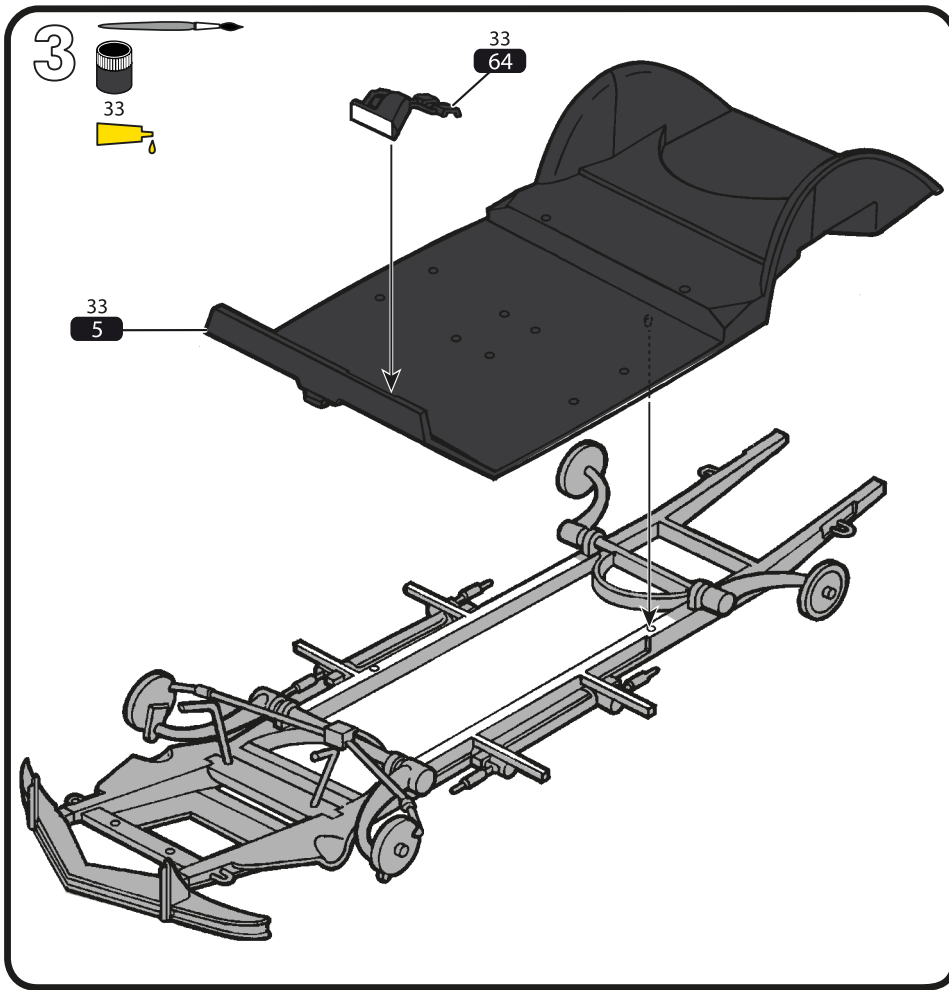

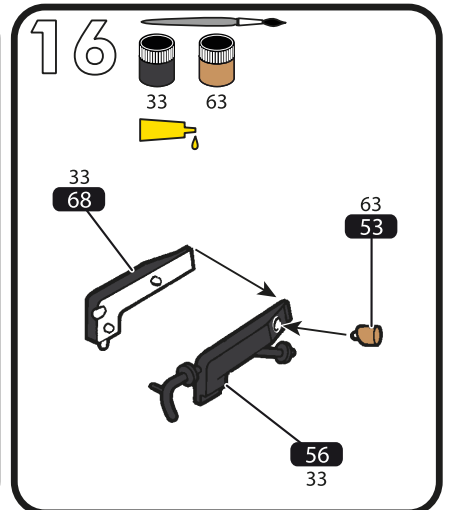
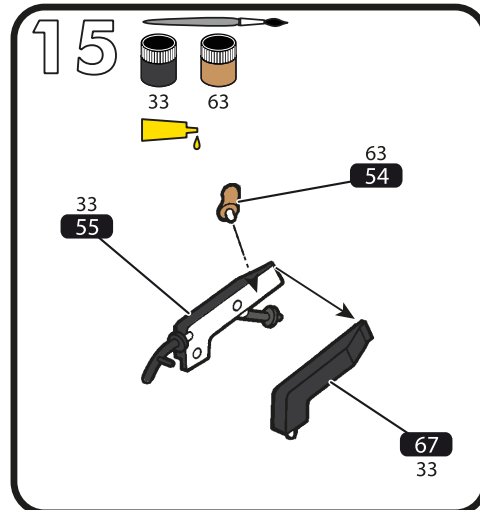
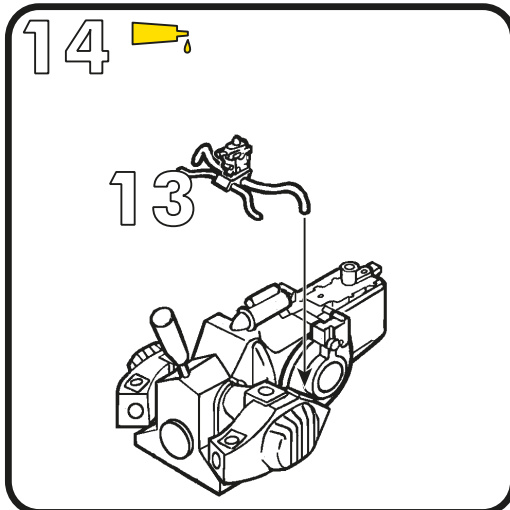
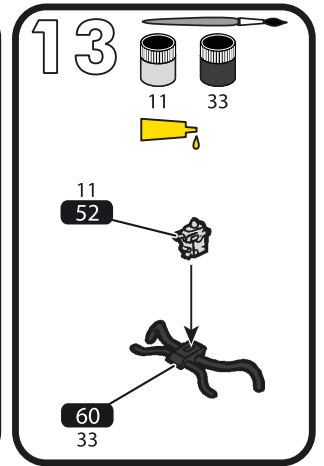
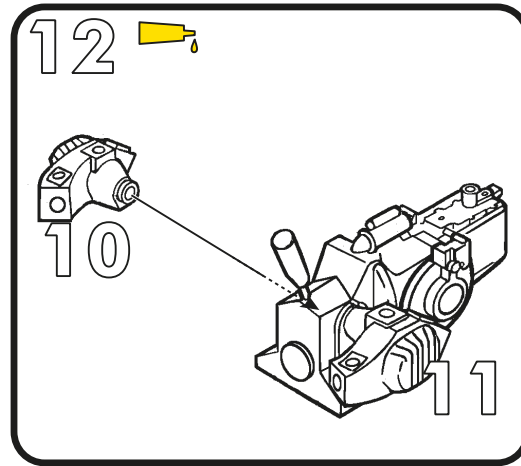
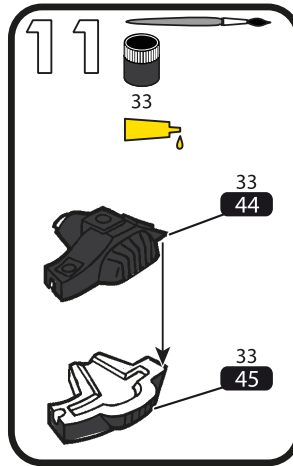
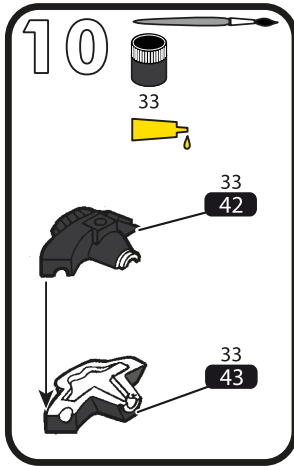
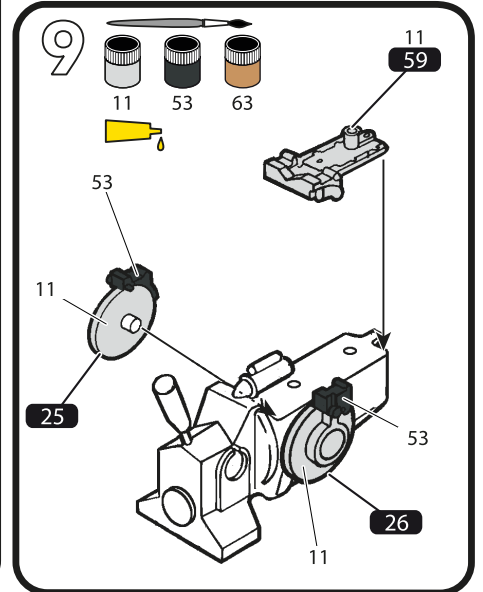
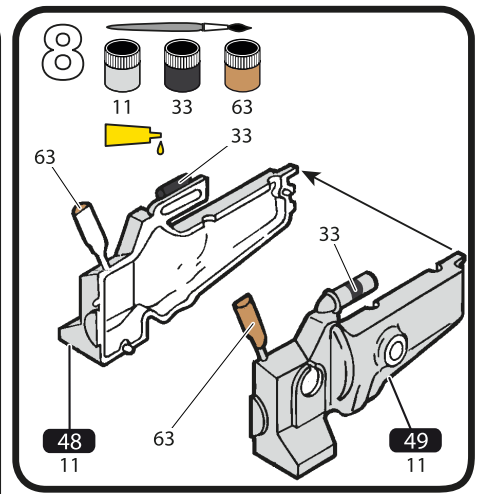
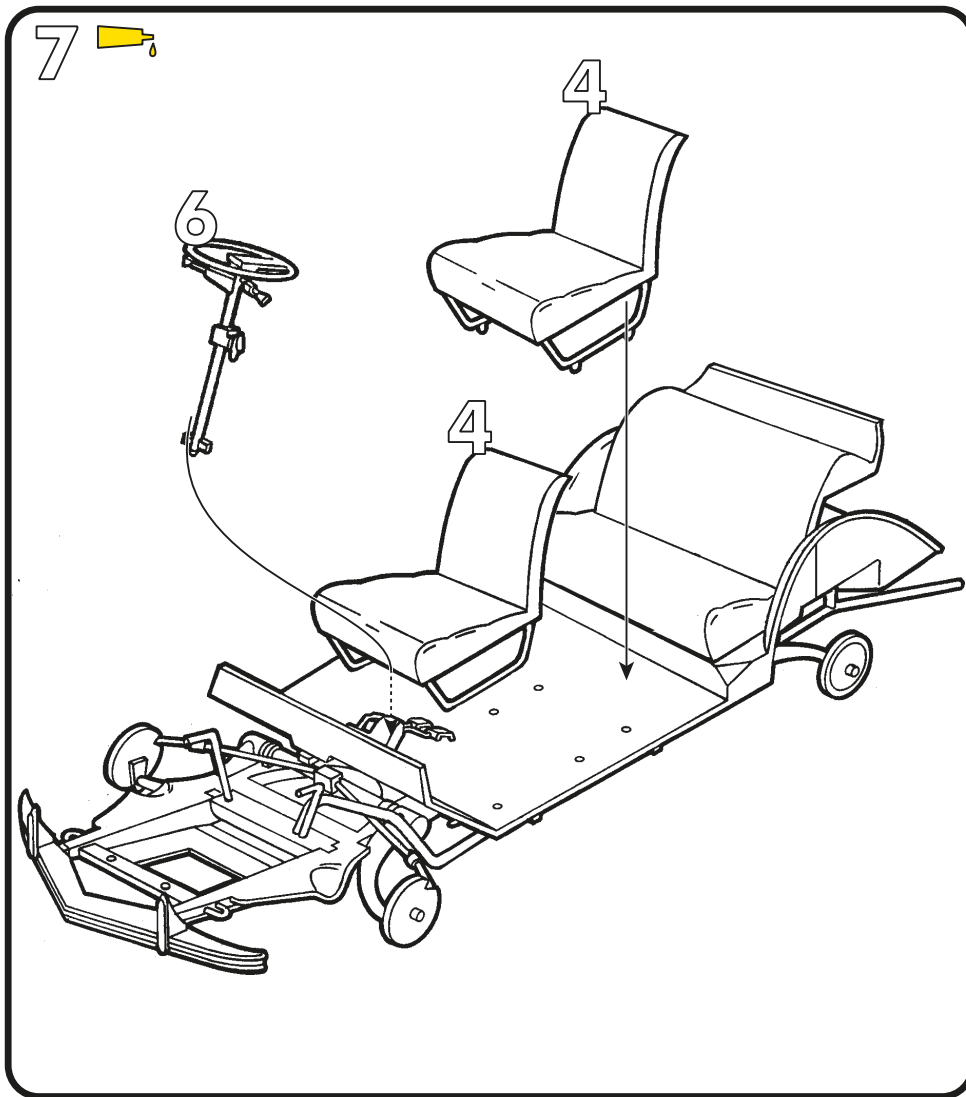

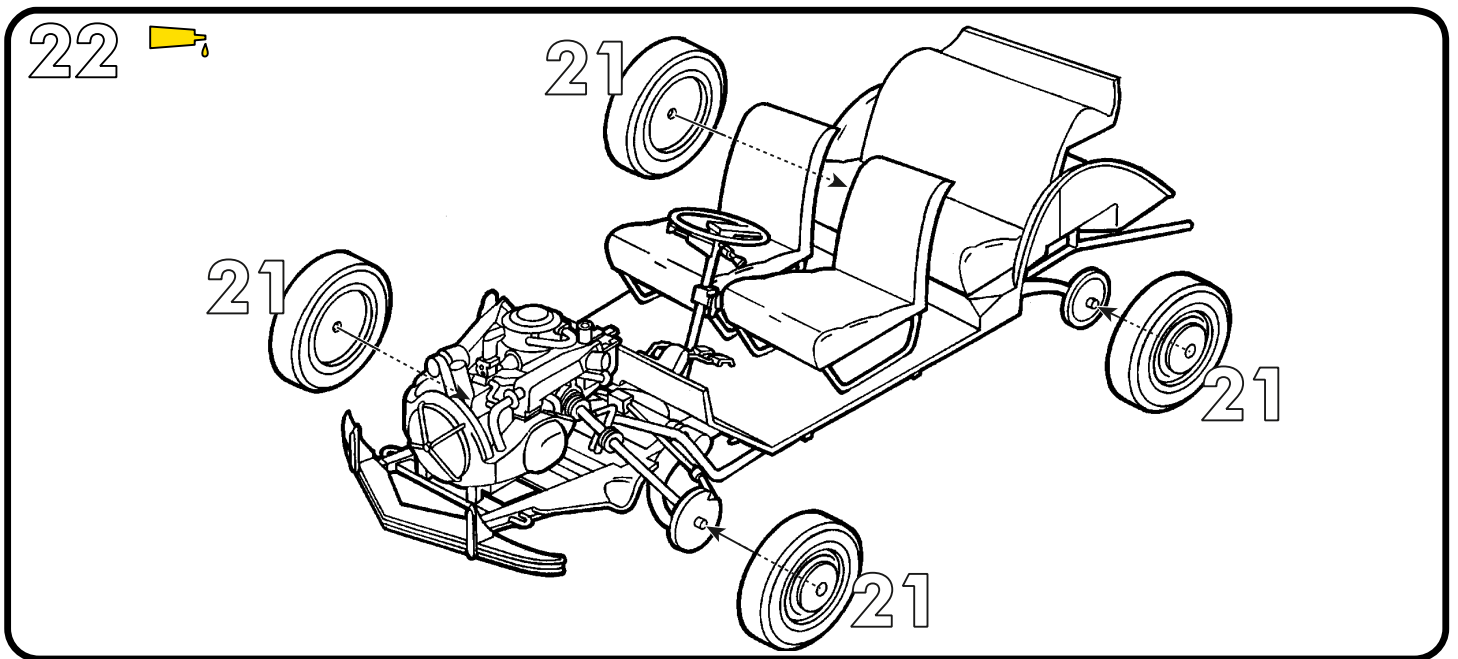
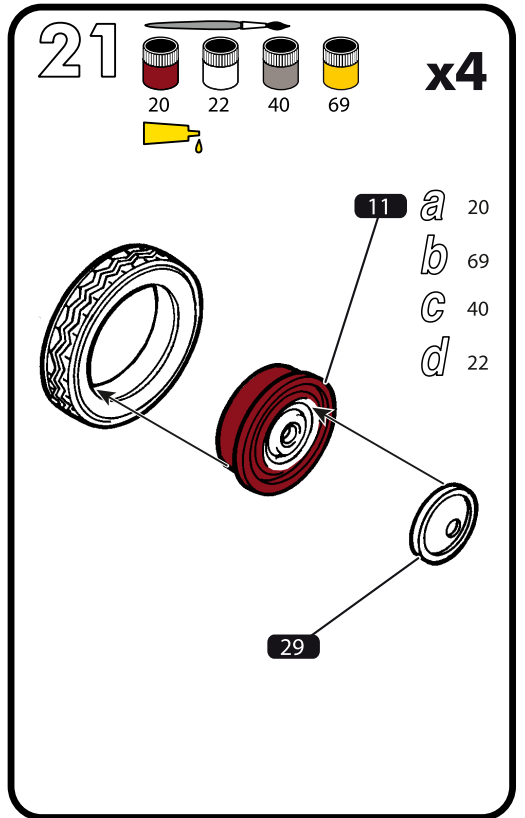
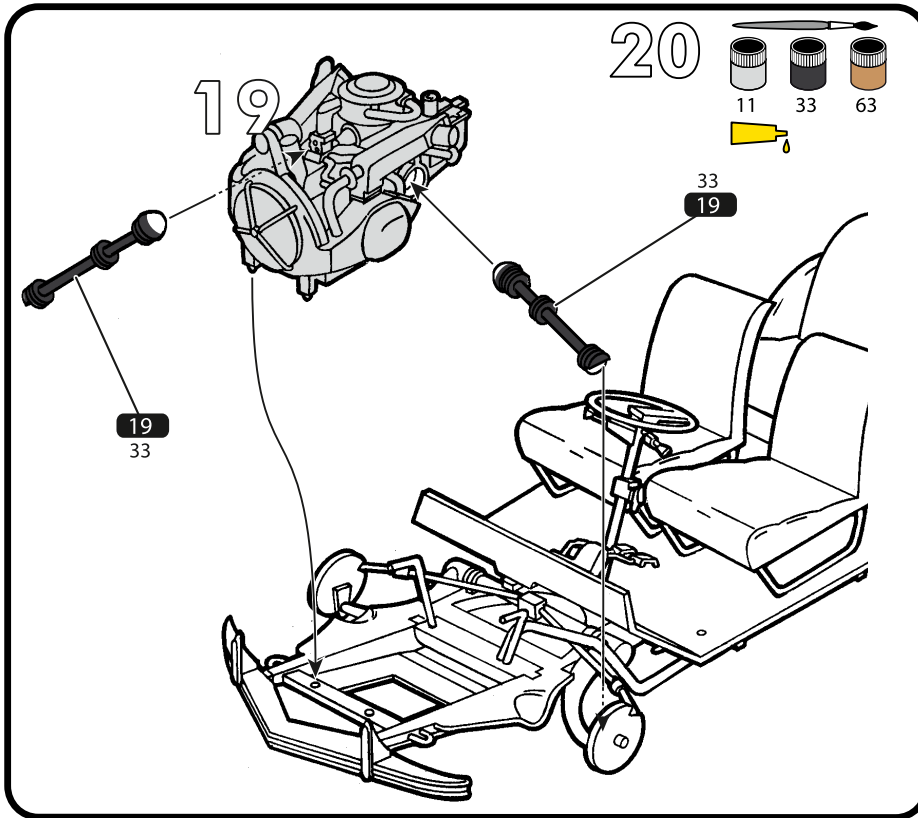
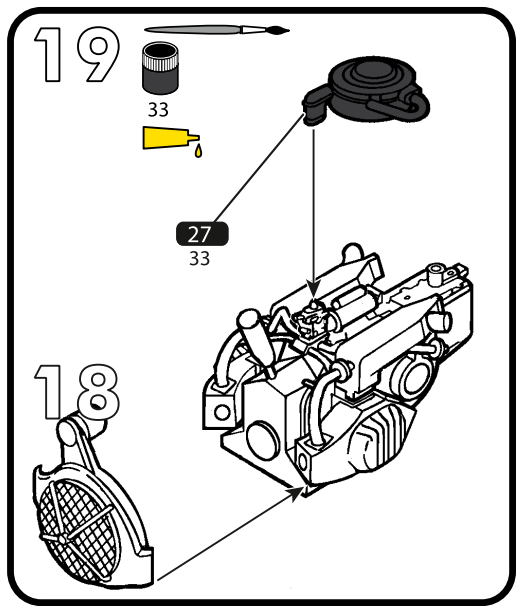
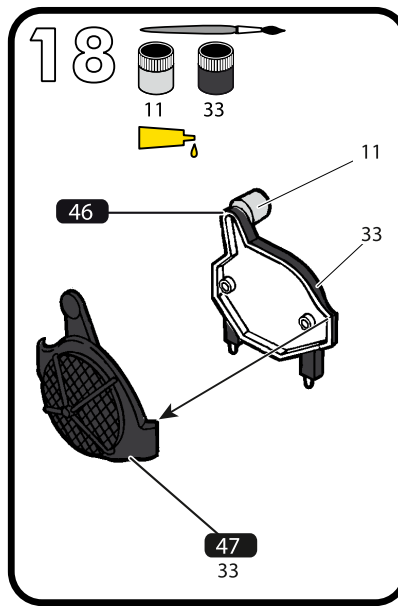
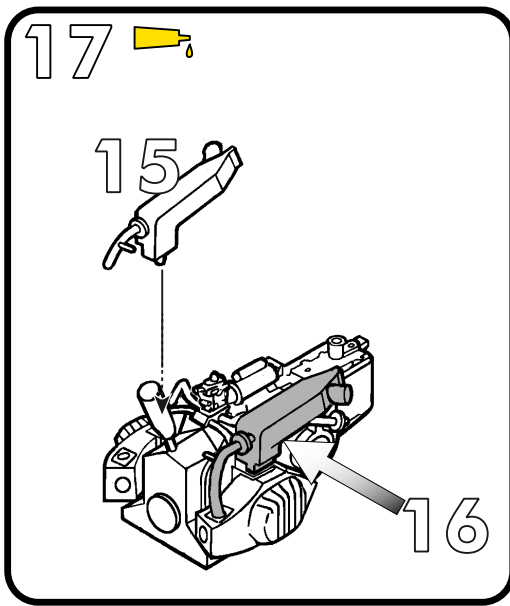

23

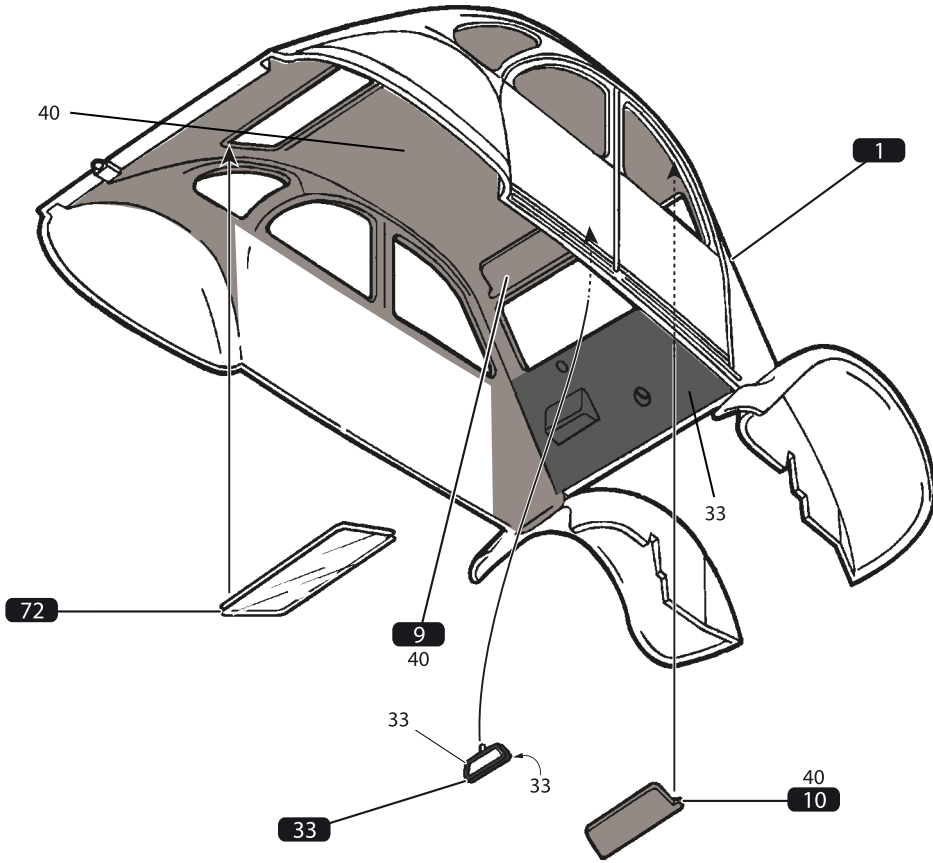
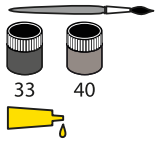

24

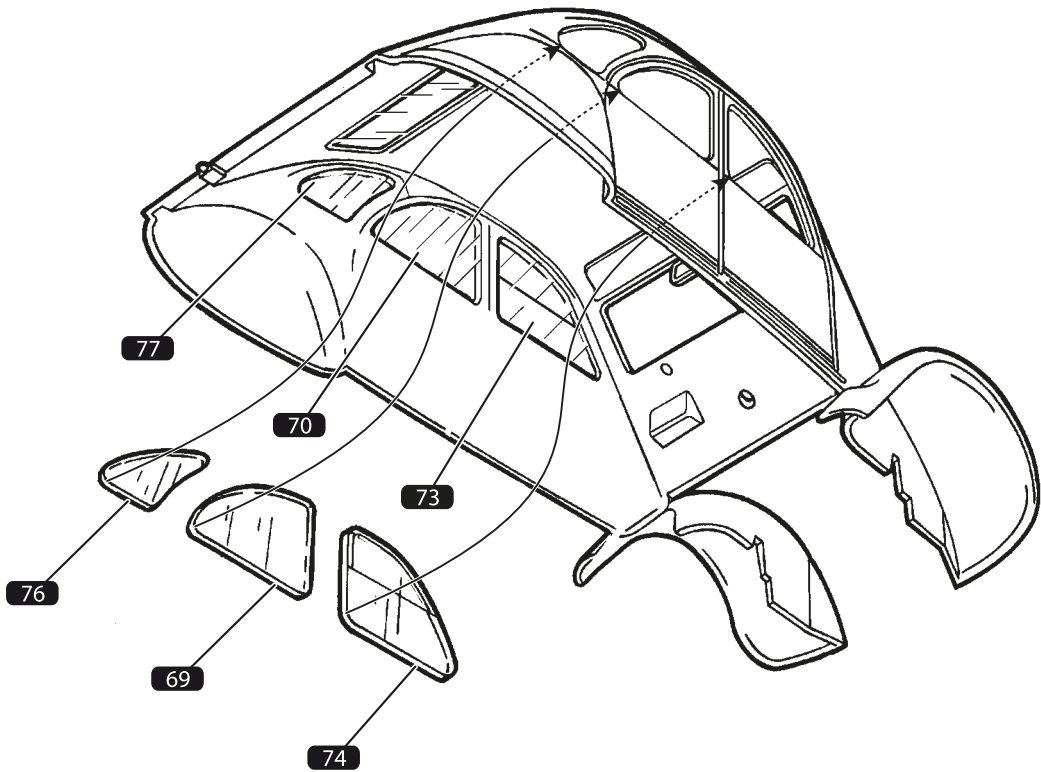

25

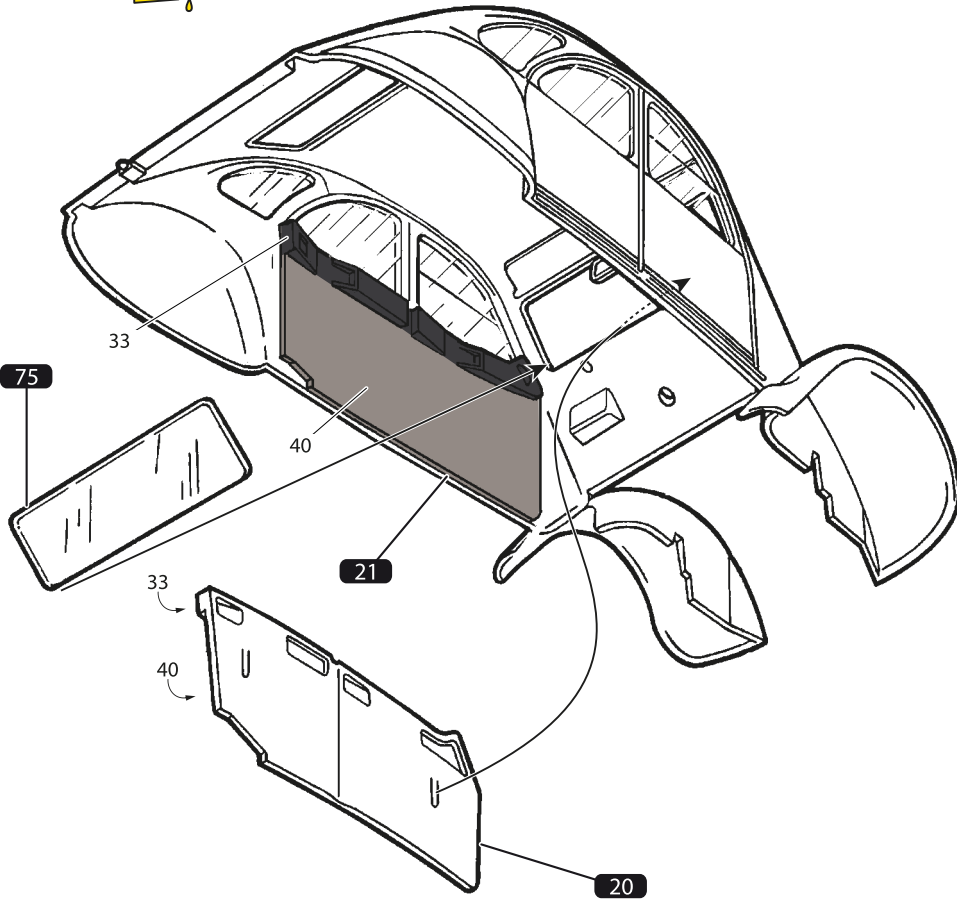
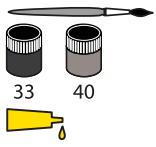

26

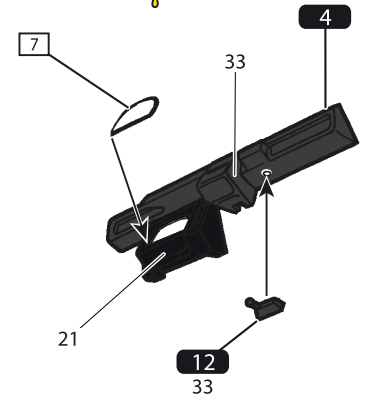
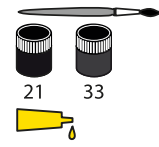

27

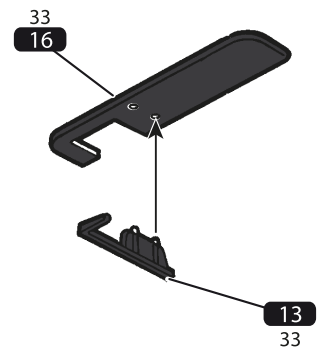
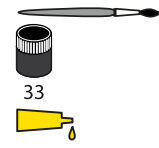

28

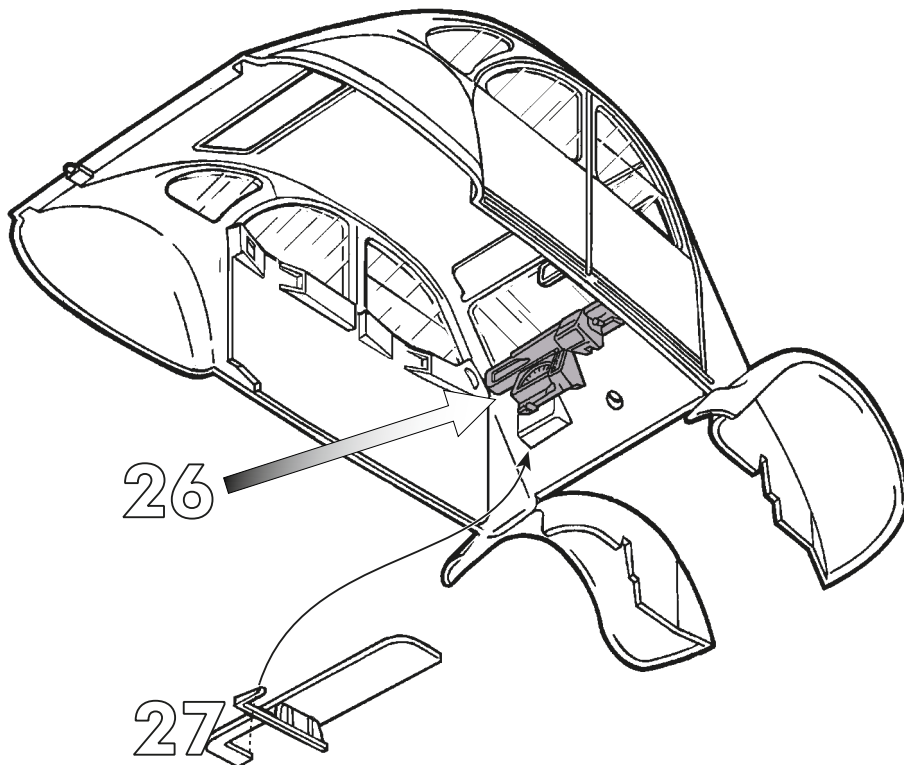

29

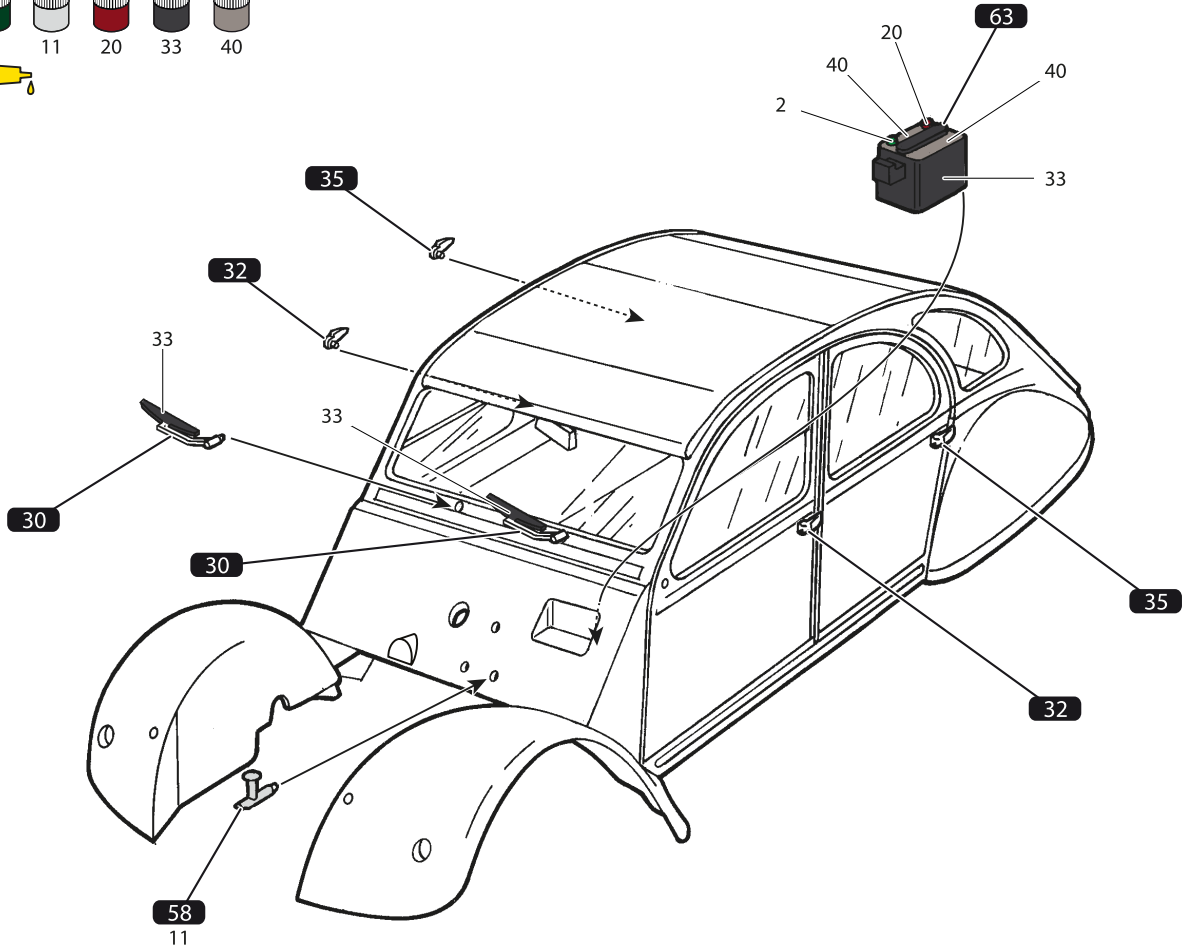
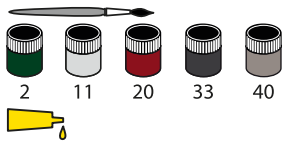

30



a↔b c↔d

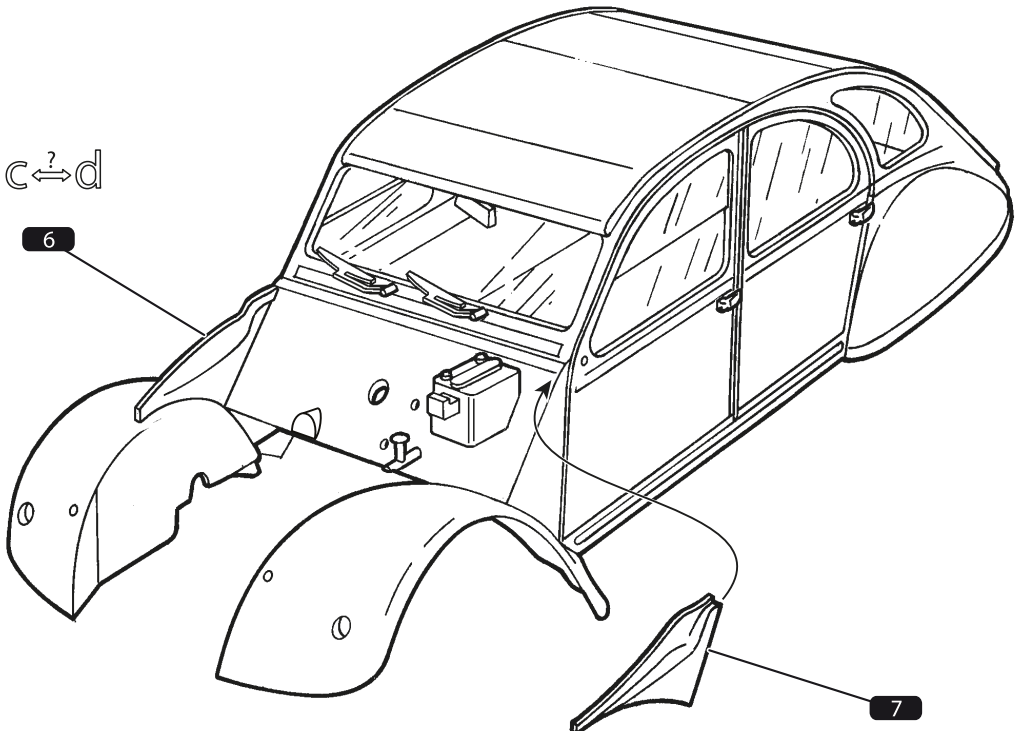

a↔b c↔d

31 

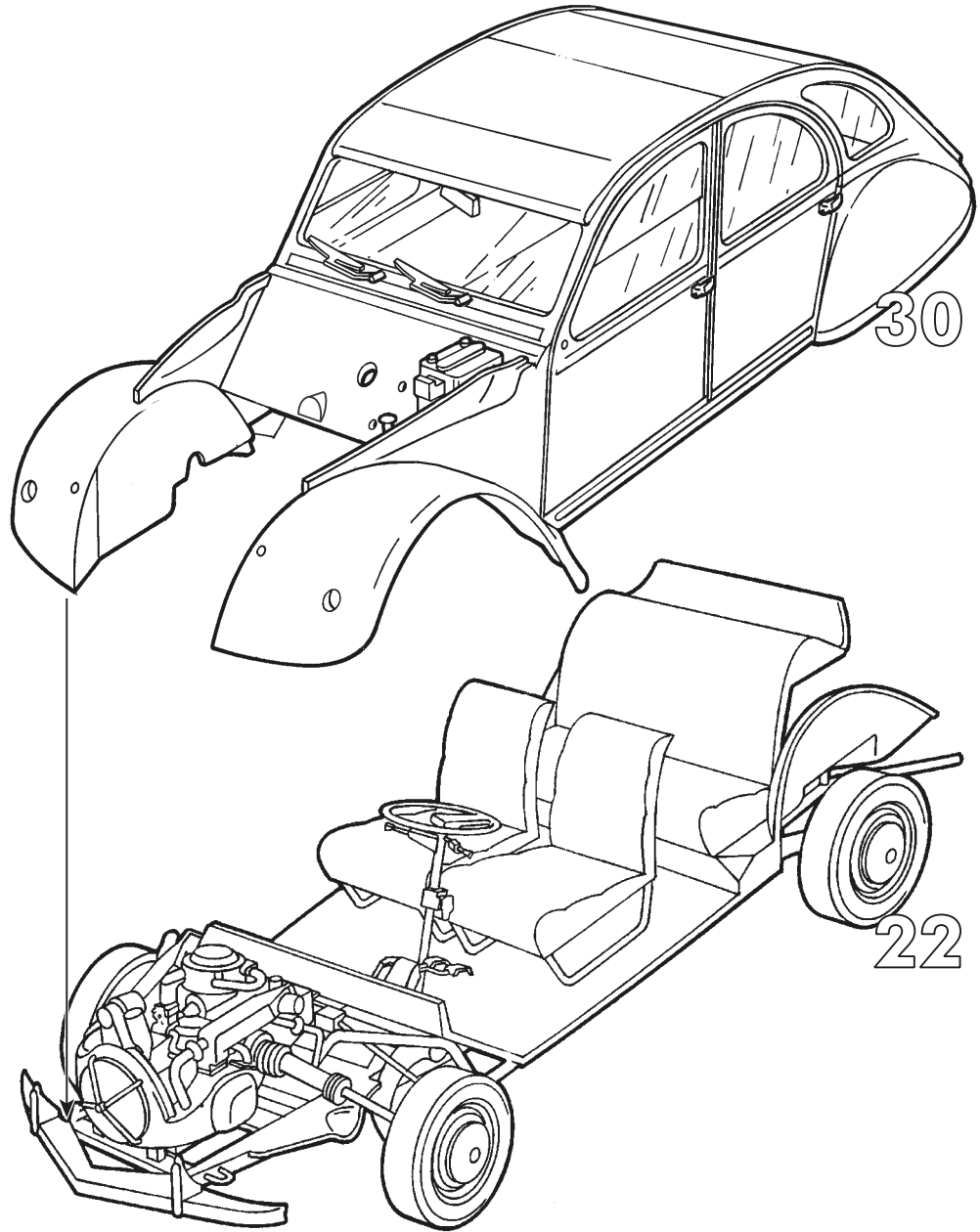

32 

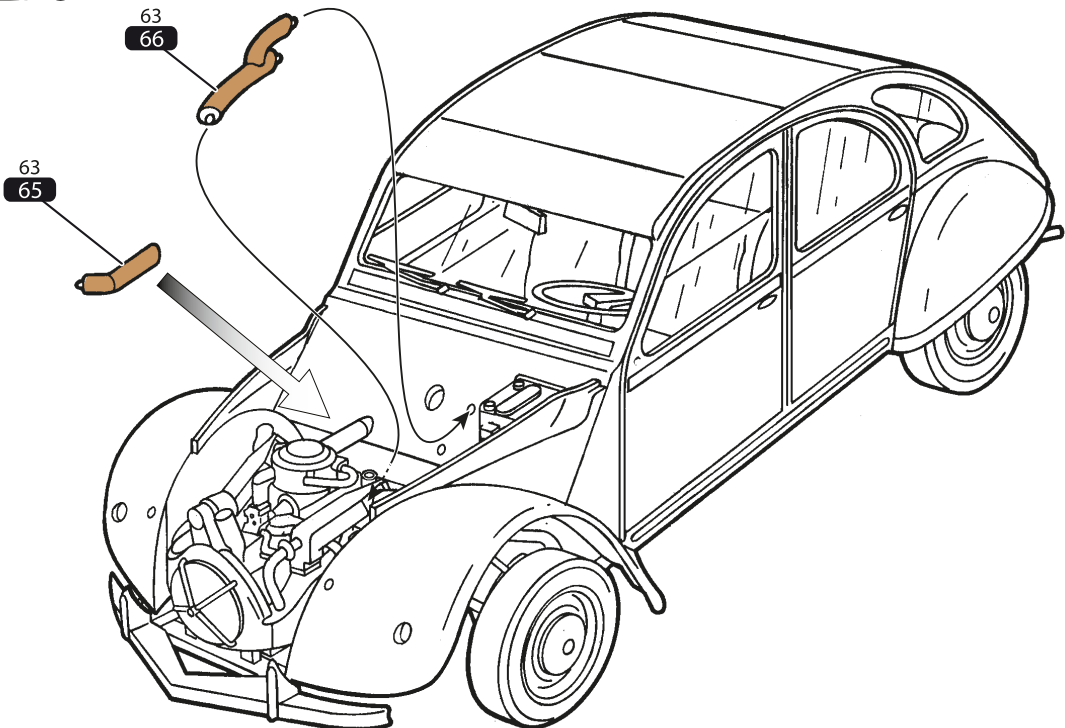

33

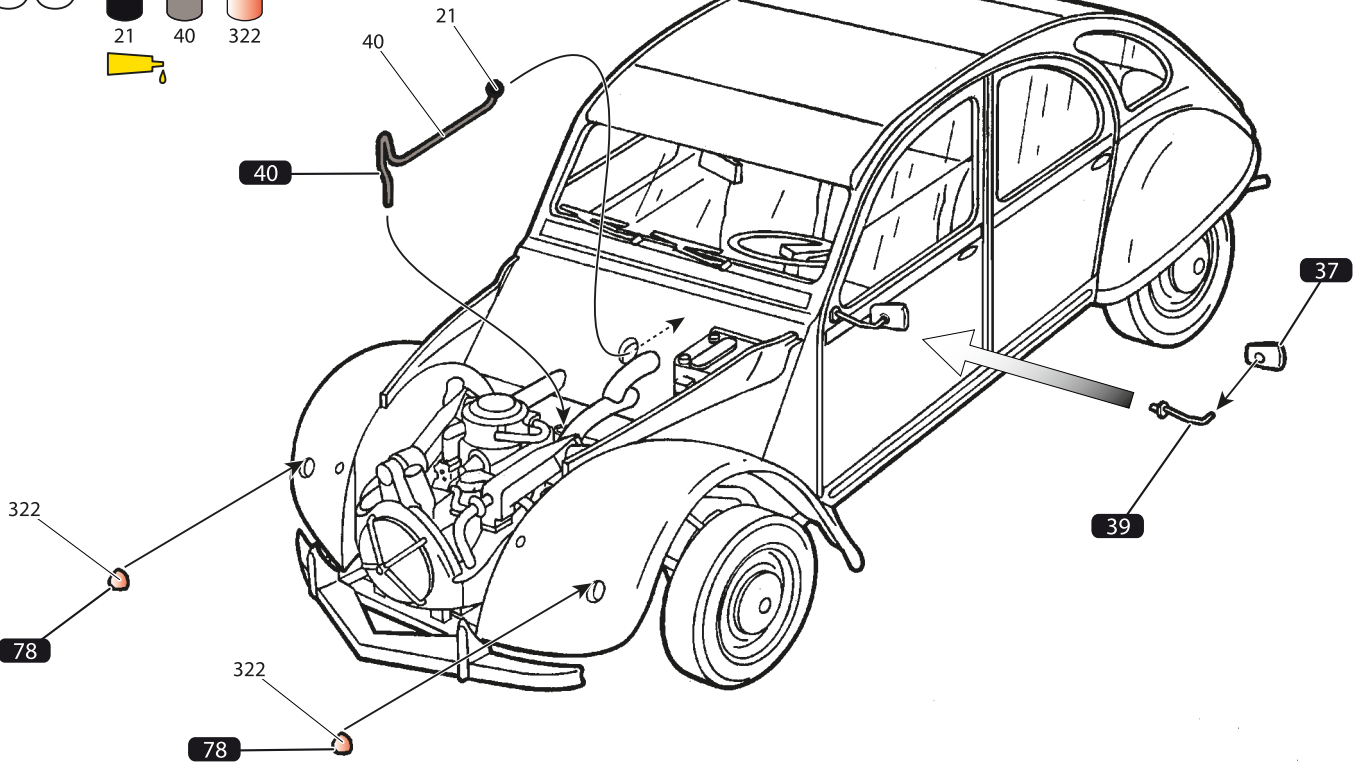
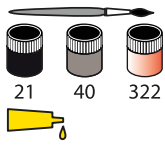

34

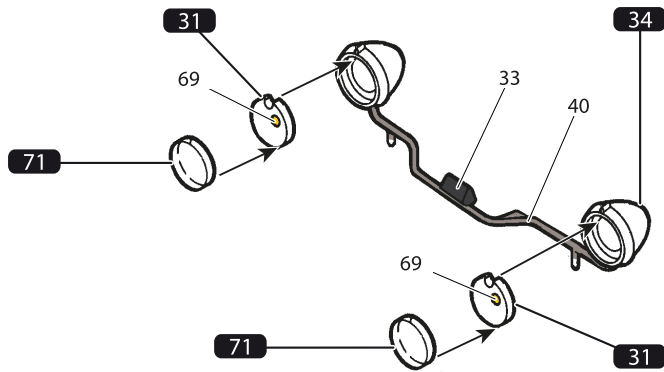
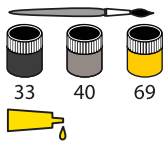

35

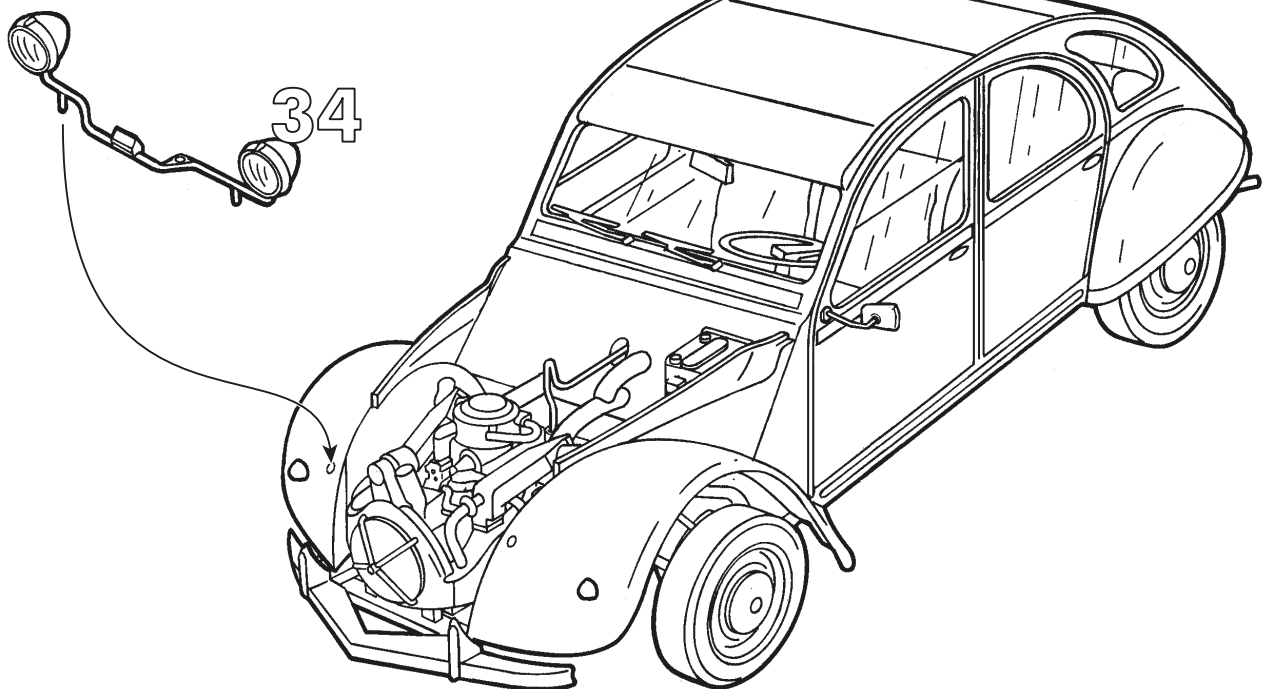

36

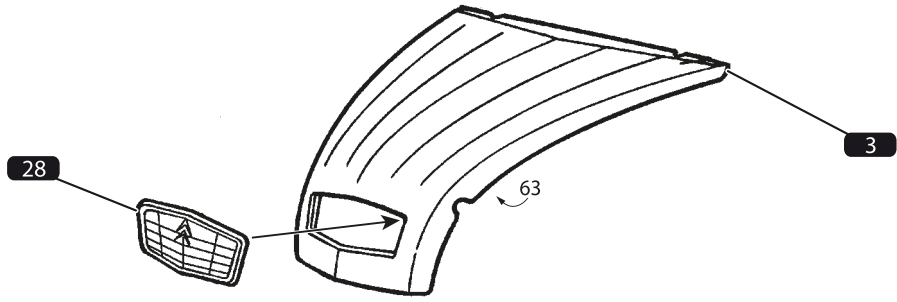
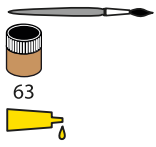

37

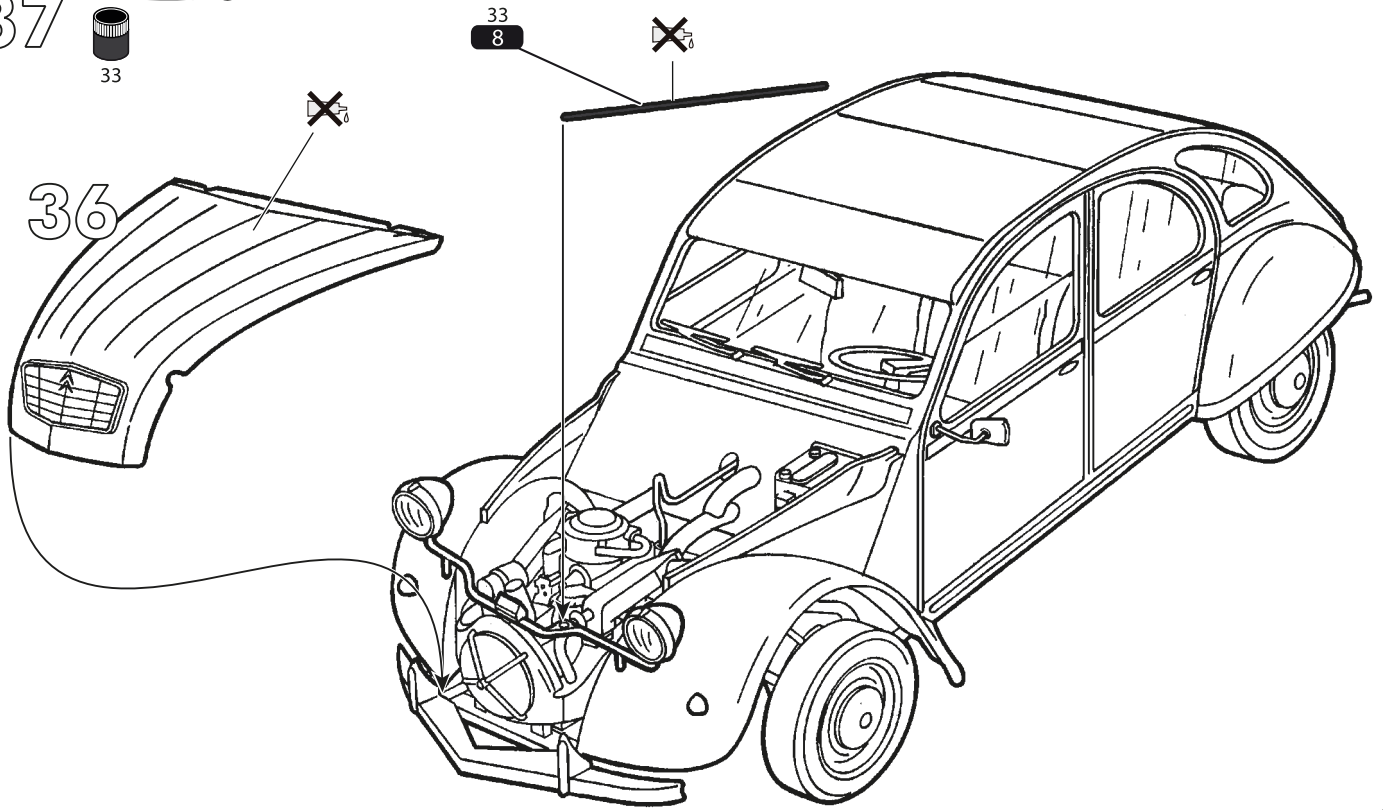
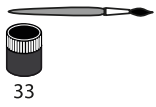

38

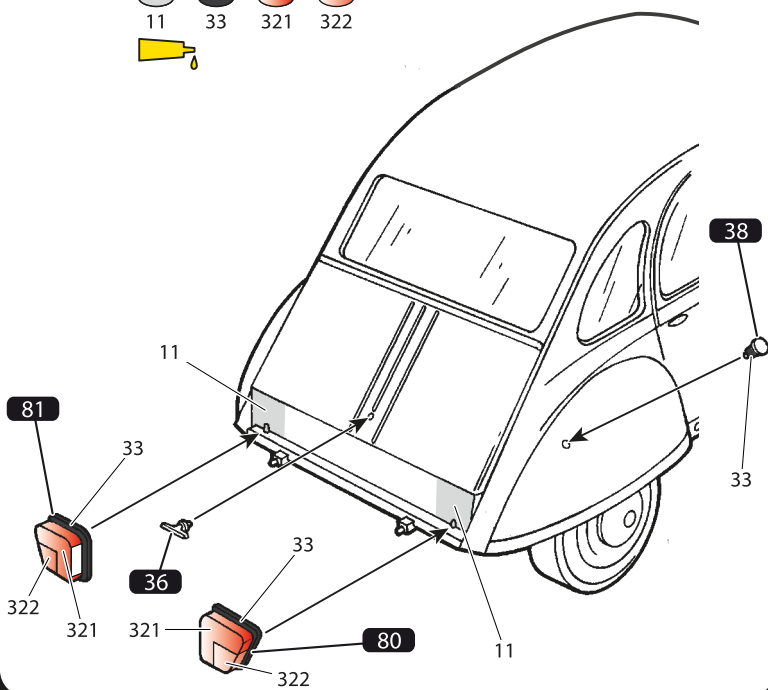
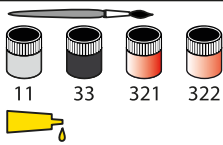

39

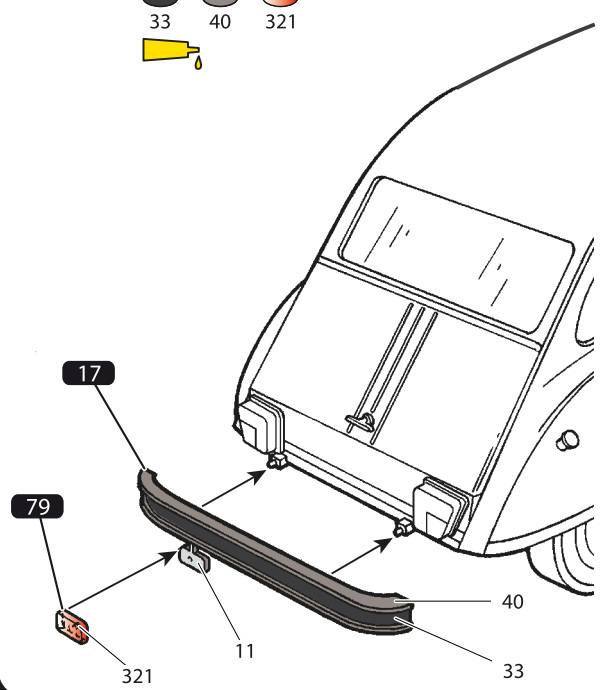
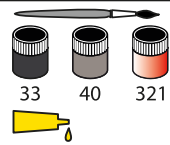

40

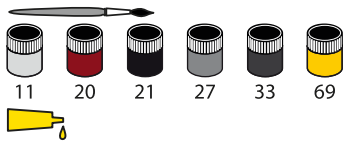

a 2CV Charleston rouge Delage

b 2CV Charleston jaune Hélios

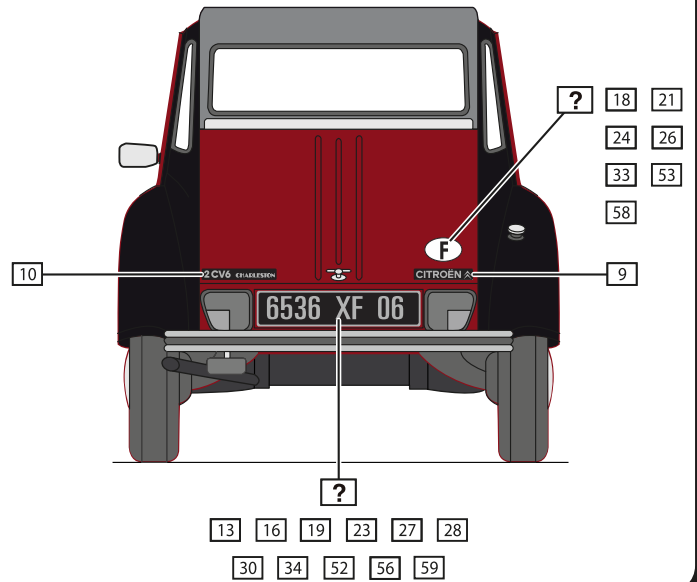
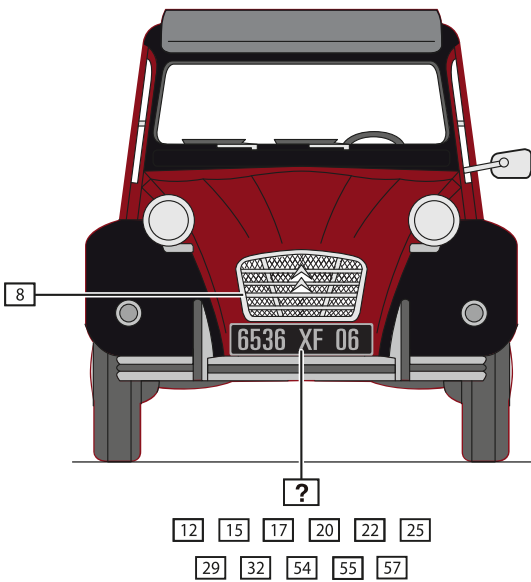
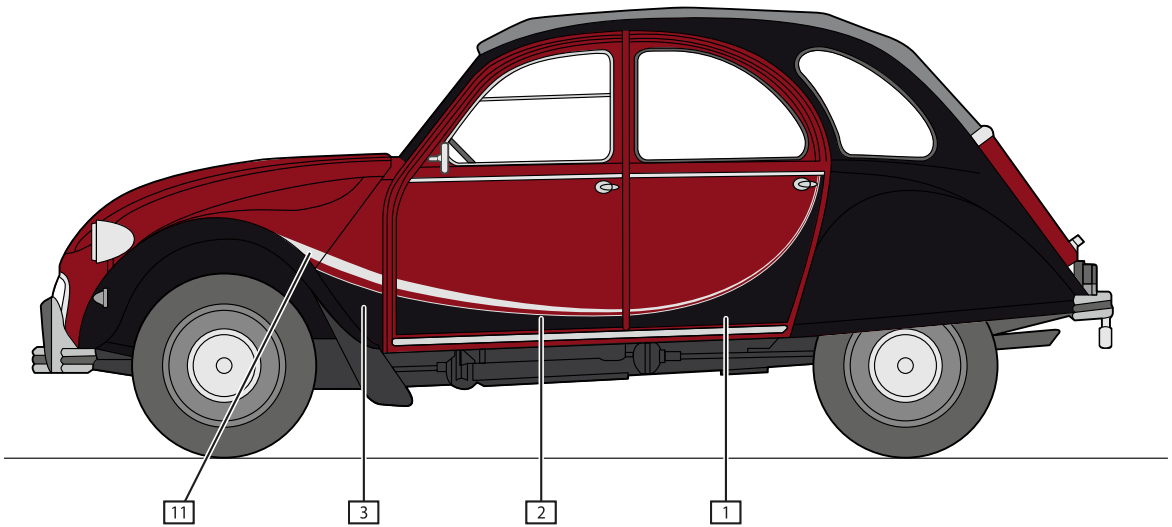
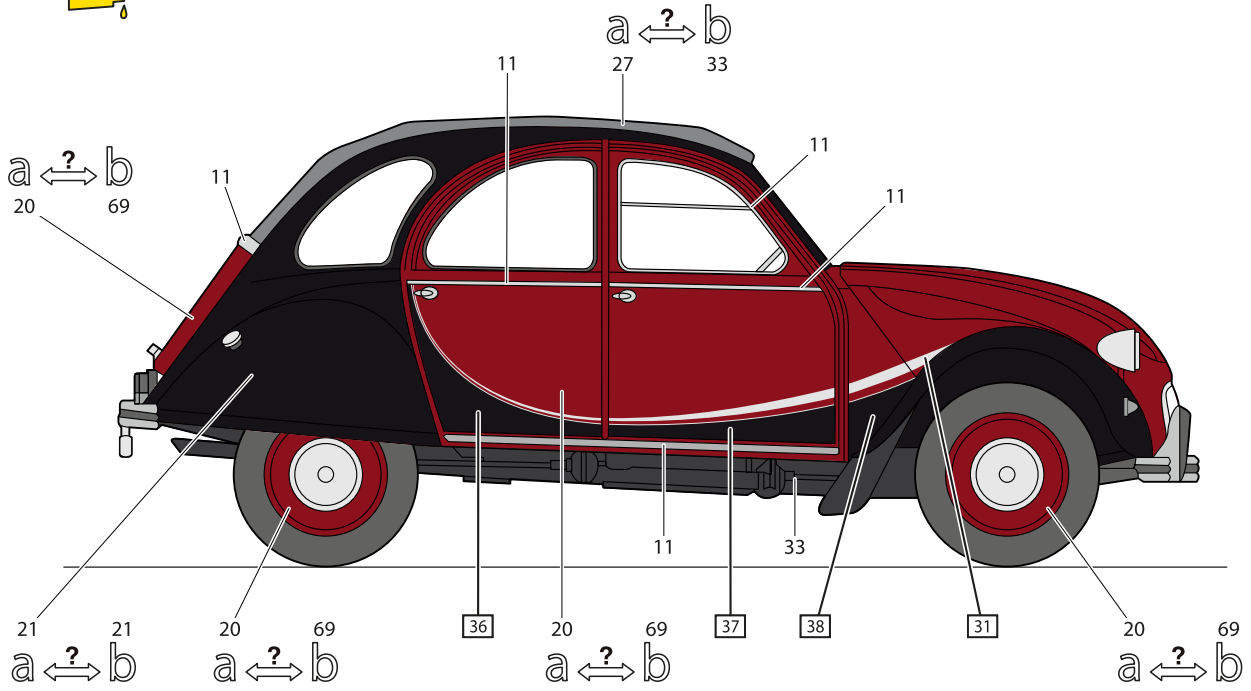

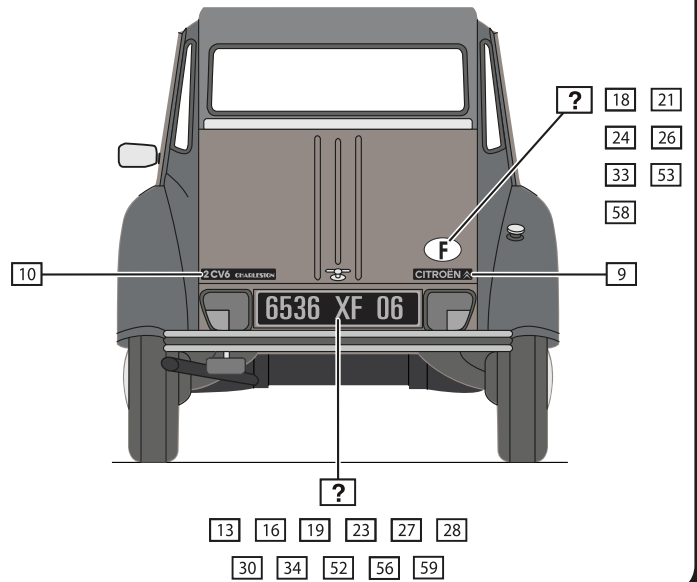
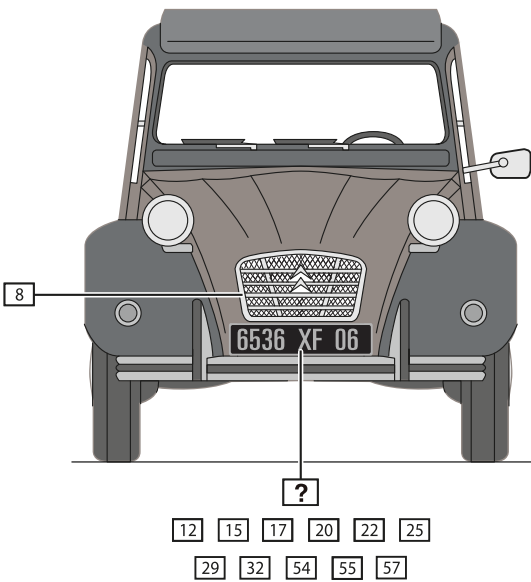
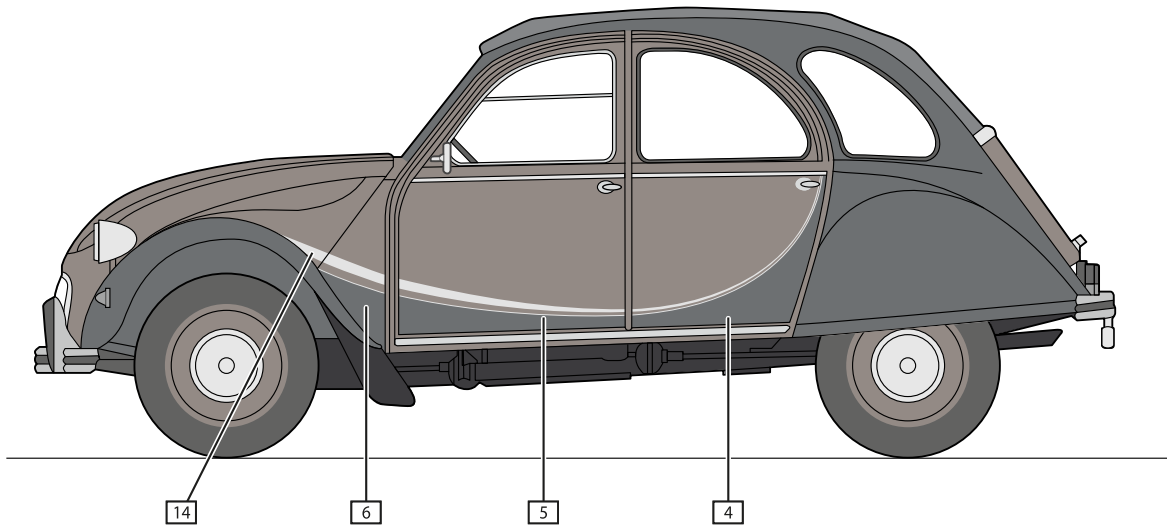
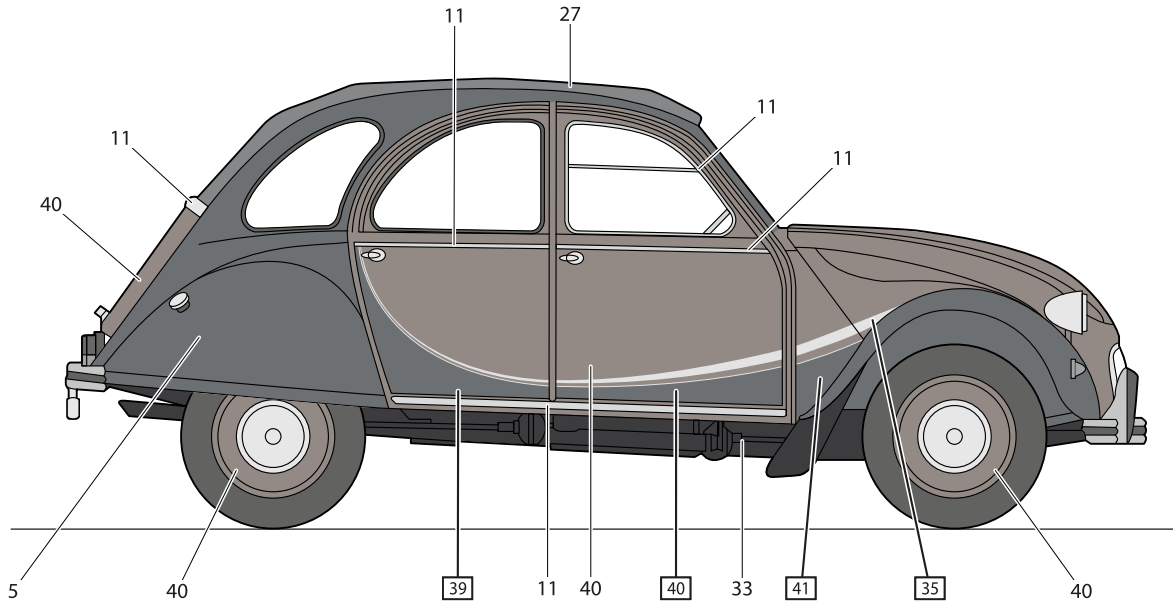
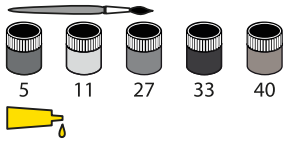

42

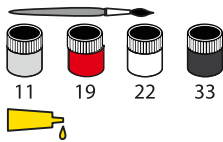

d 2CV Dolly

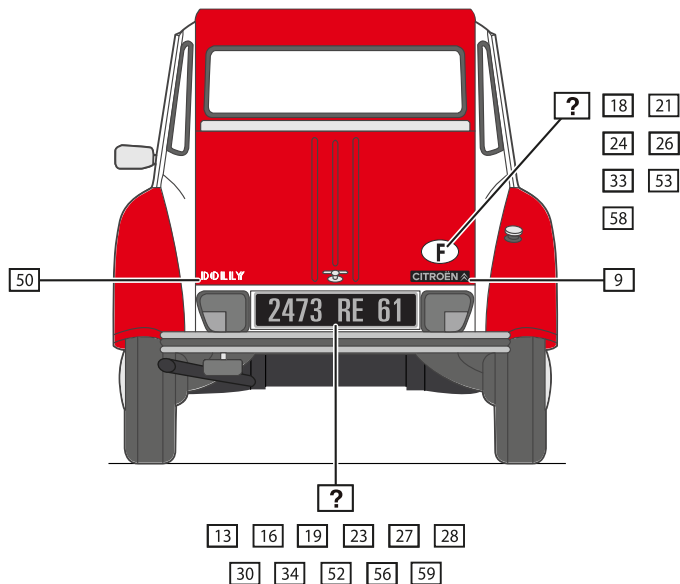
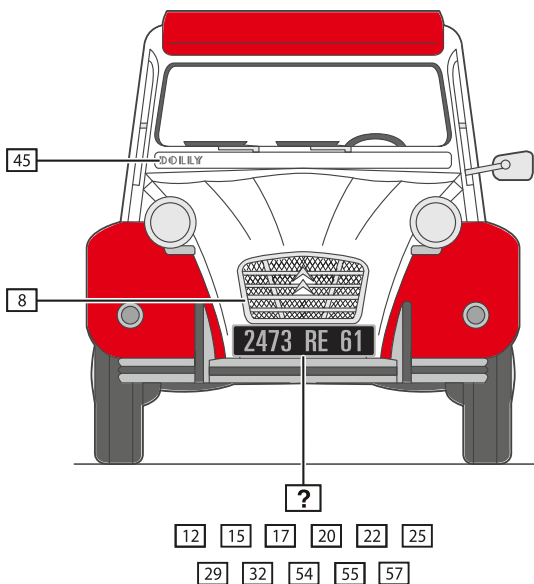
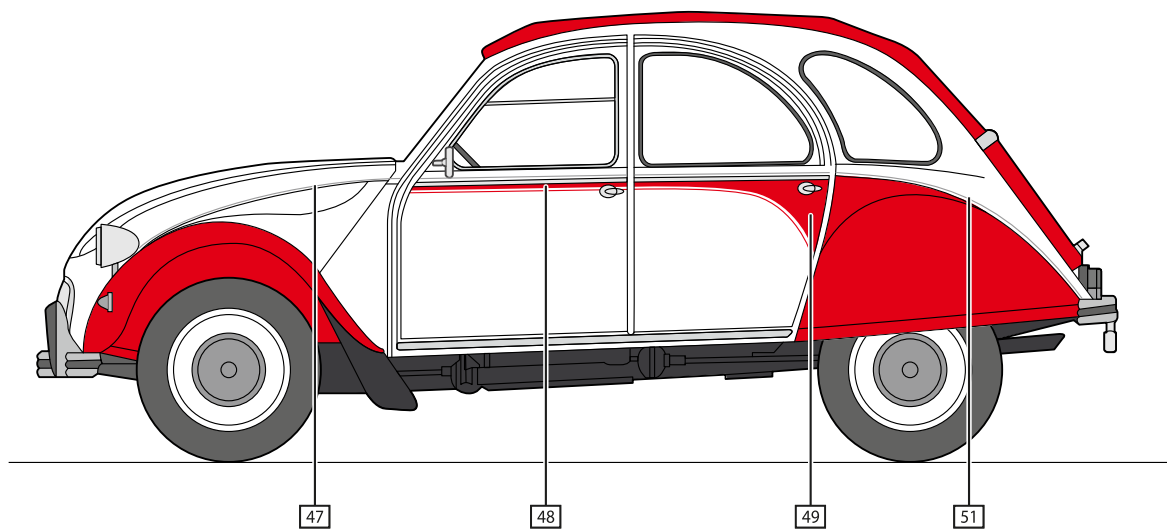
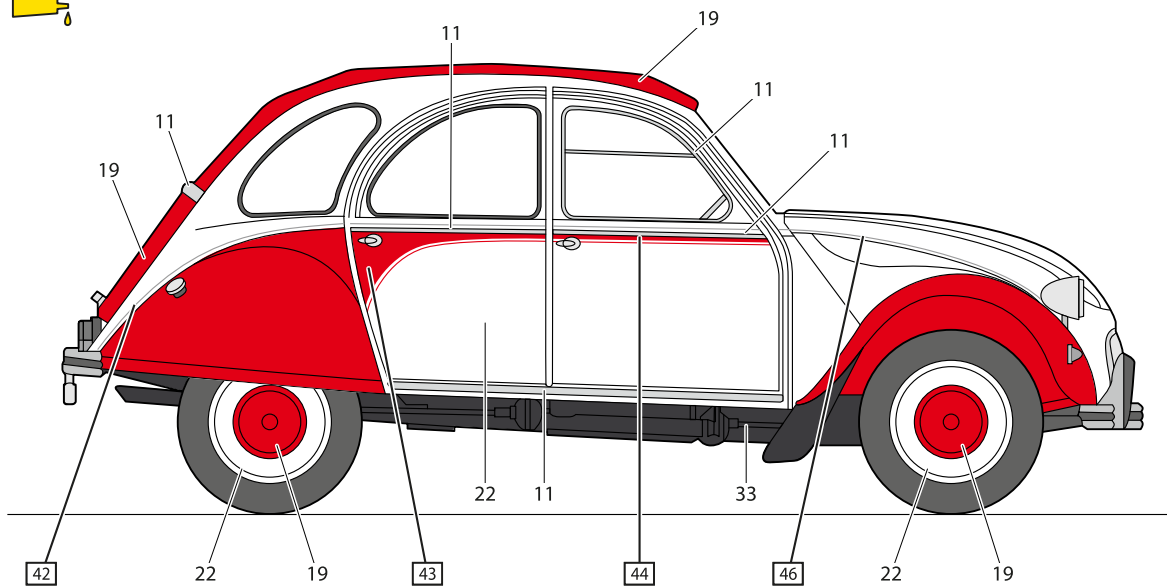

VISITEZ-NOUS EN LIGNE !

VISIT US DIGITALLY!
BESUCHEN SIE UNS DIGITAL!

 www.heller.fr

 [instagram.com/heller.fr](https://www.instagram.com/heller.fr)

 [facebook.com/heller.fr](https://www.facebook.com/heller.fr)

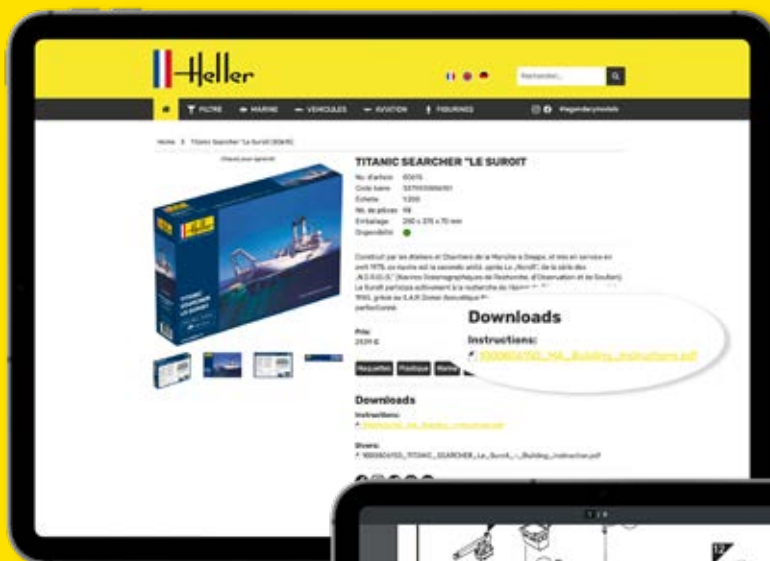

Choisissez l'article que vous désirez et téléchargez les instructions.
Choose your desired article and download the instructions.
Wählen Sie den gewünschten Artikel und laden Sie die Anleitung herunter.



**Download all
instructions!**

Grossissement des instructions pour
une vue détaillée.

Enlarge the instructions for a more
detailed view.

Vergrößern Sie die Anleitung für eine
detailliertere Ansicht.

V-070421

Service consommateurs
Pour toute demande de SAV, connectez-vous
sur notre site www.heller.fr.

Customer Service
For after-sales service requests,
please contact us through our website
www.heller.fr.

Endverbraucherservice
Bitte besuchen Sie uns auf www.heller.fr
für alle Ersatzteilanfragen.

Heller Hobby GmbH

Erlenbacher Str. 3 • 42477 Radevormwald • GERMANY

☎ +49 (0) 2195-92773-0 ✉ info@heller.fr