

REPUBLIC F-105D THUNDERCHIEF



READ THIS BEFORE YOU BEGIN

AMT kits are moulded from the finest high-impact styrene plastic. Use only paint and cement made for styrene. Trim excess plastic from parts before joining. Use just enough cement to join parts, and be careful not to smear cement on exposed surfaces.

Look over this instruction sheet carefully before you begin building. Follow the assembly instructions and "test fit" the parts without cementing. This will familiarize you with the fit and location of the parts.

Built according to the instructions on this sheet, you should have no trouble assembling your model.



HASEGAWA

ASSEMBLY INSTRUCTIONS FOR REPUBLIC F-105D THUNDERCHIEF

Step 1: Cement pilot (24) to seat (25) and cement seat to right fuselage side as shown. Cement fuselage halves together and attach pitot tube (13) to nose.

Step 2: Cement left intake separator (16) to left fuselage as indicated. Cement lower left wing (6) to upper left wing and attach wing to fuselage. Repeat for right wing. Now cement stabilizers (7 and 8) to fuselage assembly. Cement tailpipe (12) to fuselage and cement cockpit canopy into position.

Step 3: Cement fuel tank top (39) to tank bottom (38) and attach pylon (27) to tank. Repeat with parts (28, 40, and 41) and set aside. Slide nose wheel (11) onto axle of nose strut (9). Carefully cement fork (10) to strut to trap nose wheel. Set assembly aside. Cement tank halves (36 and 37) together and set aside.

Cement main wheel (44) to right main strut (42). Now cement right gear door (20) to strut. Repeat for left landing gear using parts (21, 43, and 45).

Cement pod top and bottom (34 and 35) together and attach to pylon (33).

Assemble two Bullpups to their mounts as shown using parts (29, 30, 31, and 32).

Step 4: Cement sub-assemblies in place as shown. Either the large centerline tank or small pod may be used as desired. Attach left and right nose wheel doors (14 and 15) to sides of nose wheel well. Cement small strut doors (22 and 23) to base of main landing gear struts. Now cement wheel cover doors (18 and 19) in place as shown. Cement vent (26) under left stabilizer.

Your model is now ready for paint and decals. Refer to the box illustration for color scheme and decal placement.

Painting Instructions:

White - Bullpup missiles, pilot's helmet
Black - tires
Silver - landing gear struts
Light green - inside wheel doors
Green - pilot's uniform

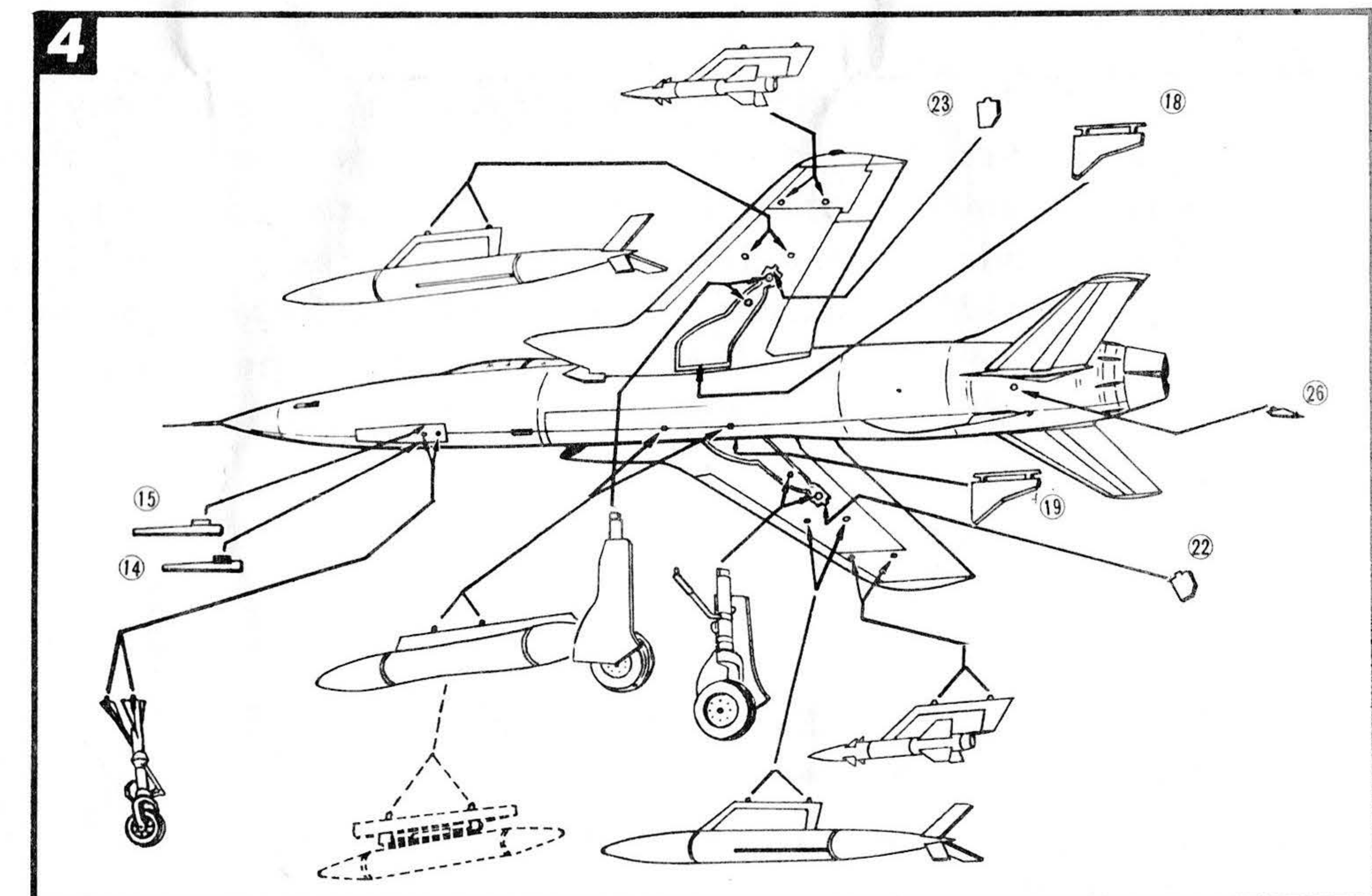
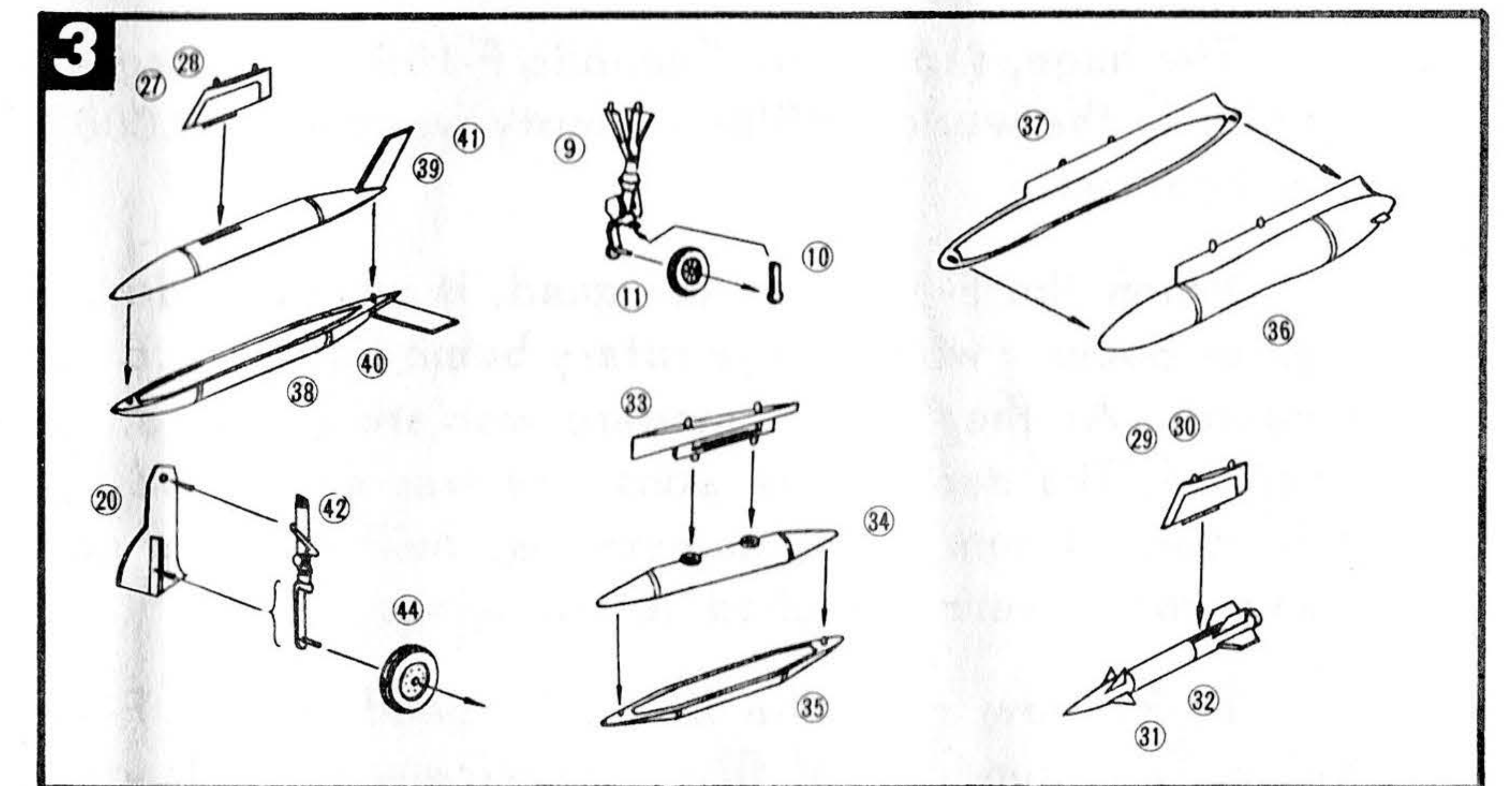
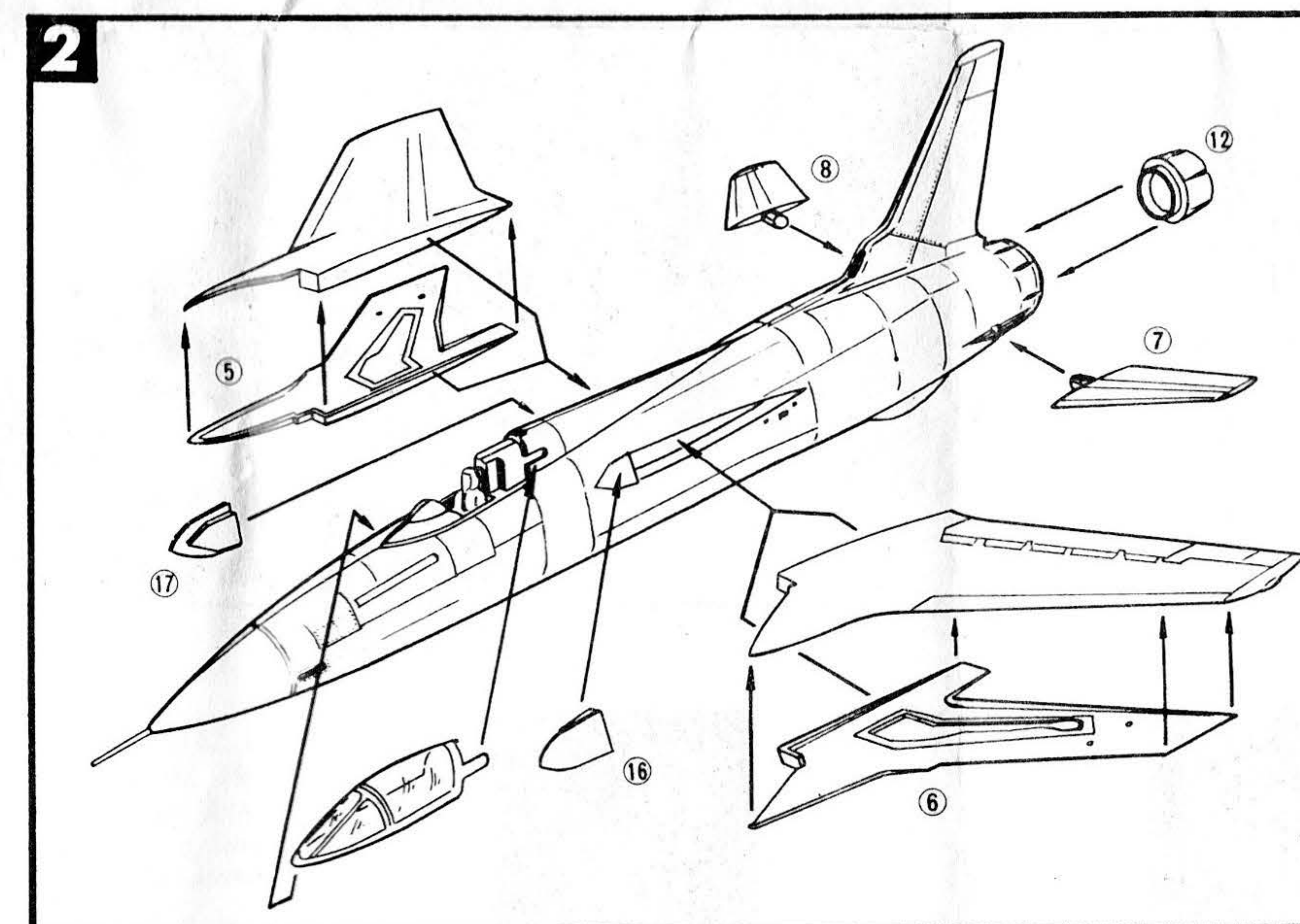
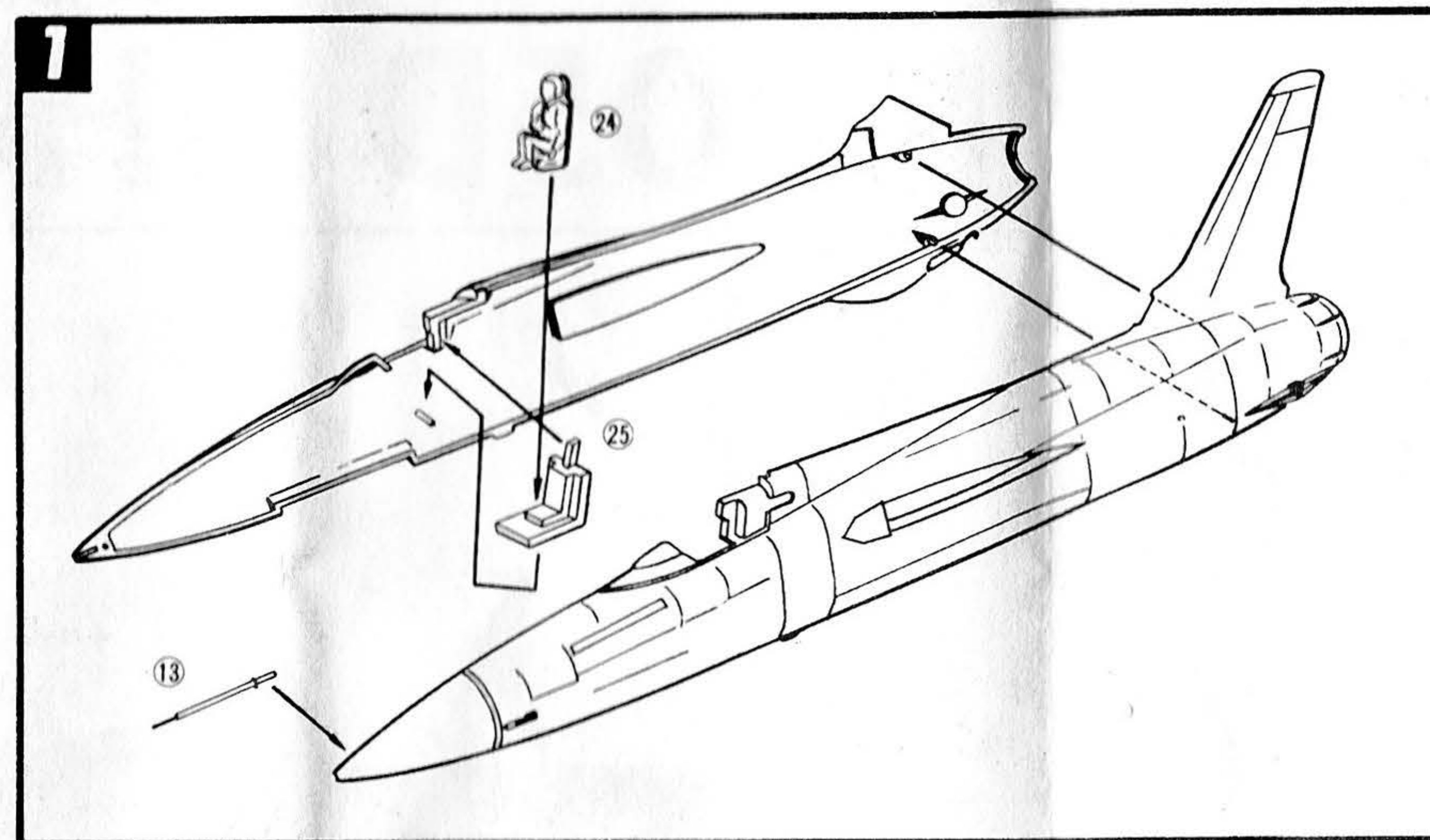

HISTORY OF THE REPUBLIC F-105 THUNDERCHIEF

The huge, supersonic Republic F-105 is the largest single-place fighter in the world. With an empty weight of 28,000 lbs., it is also the heaviest.

When the F-105 was designed, it was intended to serve as a fighter-bomber with a large rotary bomb bay able to carry a nuclear weapon. As the face of modern warfare changed, the F-105 also changed. The nuclear weapons bay was converted to a fuel tank, a Vulcan 20 mm rotary cannon was built into the nose, and fixed bomb racks were attached to the wings.

In its new role, the Mach 2 speed of the F-105 was of no value. The Thunderchief flies subsonically to its target and unloads 12,000 lbs. of bombs on the enemy. On the return trip, the F-105 becomes a potent fighter and is able to fight its way to safety if necessary.

At the first sight of the big fighter in Vietnam, many observers feared that it could not survive the rugged war. An airplane of such a complex nature would be too vulnerable to enemy fire. The Thunderchief proved them wrong and often returned home with entire stabilizers missing, or in one case, a SAM missile embedded in the rear fuselage. The doubters called it the "Thud". Now the term "Thud" is used with affection and admiration.

REPUBLIC F-105D THUNDERCHIEF CHARACTERISTICS

Wingspan - 34 feet 11-1/4 inches

Length - 67 feet

Engine - One Pratt & Whitney J75-P-19 rated at 24,500 lbs. of thrust with afterburner

Top Speed - 1,390 mph (mach 2.1)

Armament - one M-61 Vulcan rotary cannon, up to 12,000 lbs. of bombs or missiles



HASEGAWA