

LOCKHEED L-188 TURBOPROP ELECTRA

in 1/144 SCALE

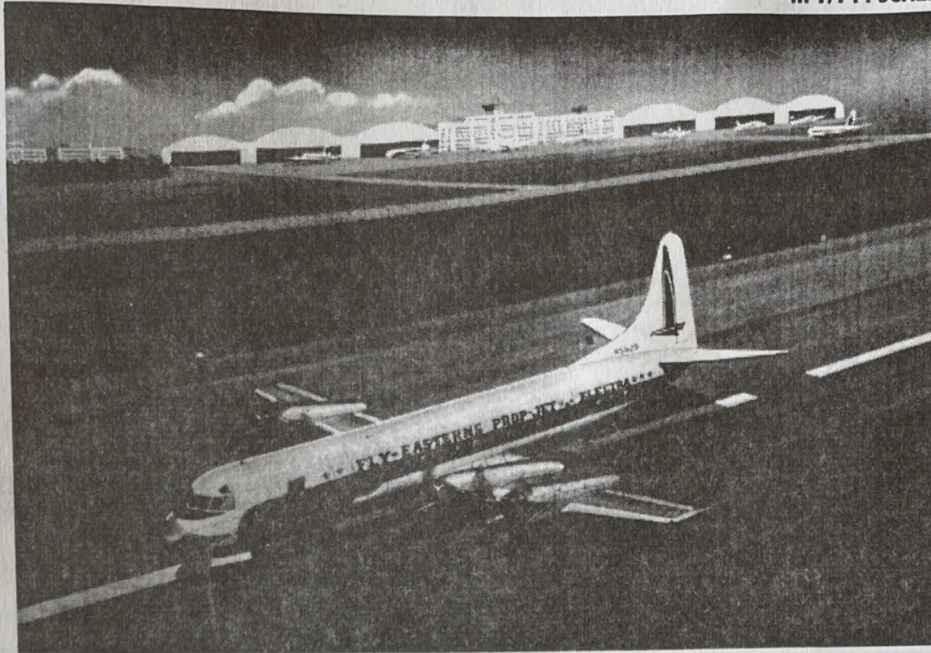

With the development of the turbojet engine, aviation was on the threshold of a bold new generation of aircraft design. However, the first of the new jet engines did not yield much more power than existing reciprocating types. The jet did provide more speed but at the expense of high fuel consumption. This was a cost even the military had problems with, but for an airliner it translated into speed for only a few passengers, because of the need for a large quantity of fuel. The first jetliner, the DeHavilland Comet, could carry only 36 passengers for a distance of 1,750 miles. Lockheed's Super Constellation, however, could carry 106 passengers over 4,000 miles, although at only half the speed of the Comet.

Jet power clearly had advantages even in its early stages, and the first jets did prove popular. To use the best features of the jet engines, the turboprop was developed. The jet engine is most efficient when operating at full power. Therefore, the turboprop was designed to be operated at its maximum RPM most of the time. On the ground, it runs at a lower speed, referred to as "ground idle". But throughout the flight, the engine runs at its highest RPM. Speed is adjusted by changing the propeller pitch, thus, the turboprop runs at its most economical speed.

The Lockheed Electra first flew on December 6, 1957, and began airline service with Eastern on January 12, 1959. Although its history was marred by three tragic accidents, the Electra, none the less, proved to be a very good airliner, especially on short routes where it nearly equaled the performance of pure jets but at a substantially lower operating cost.

Production of the Electra came to an end with the 170th plane, but the basic type has continued in production as the P-3 Orion Navy reconnaissance bomber, which is in service with many countries throughout the world. Even today, the Electra can be seen in use with several freight and cargo companies.

The Electra is powered by four Allison 501D engines with 3,750 eshp, carrying up to 100 passengers at a top speed of 448 mph and a range of 2,770 miles.

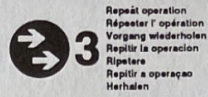
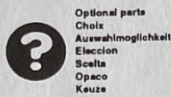
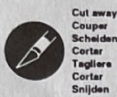
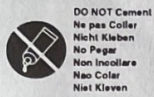

1 FUSELAGE ASSEMBLY

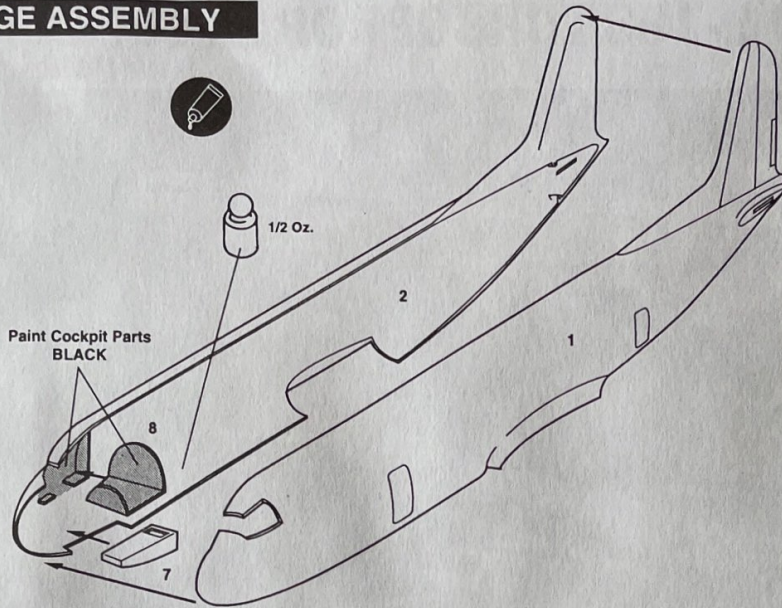

2 WINGS

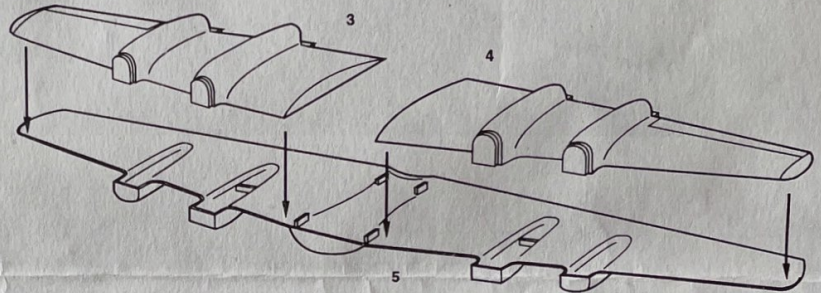

3 EXHAUSTS

Left & Right Sides

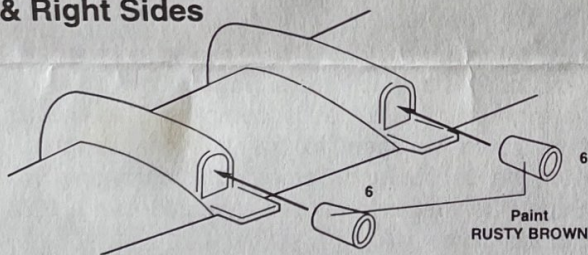

4 WING / FUSELAGE / STABILIZERS

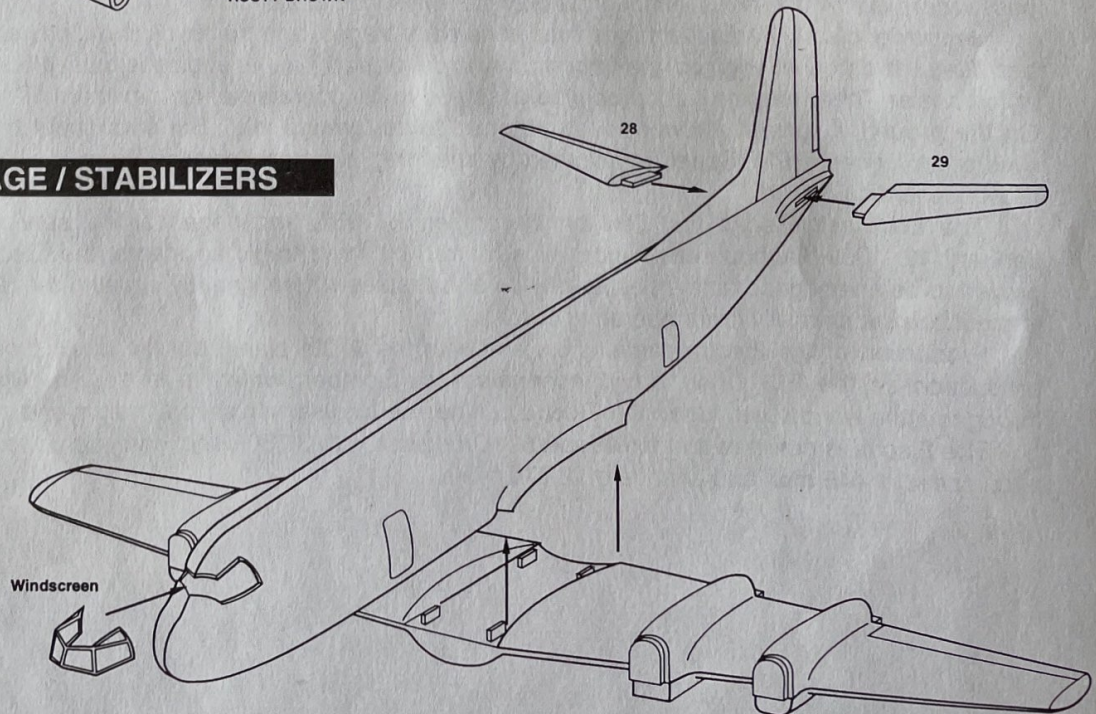

(5) NOSE GEAR

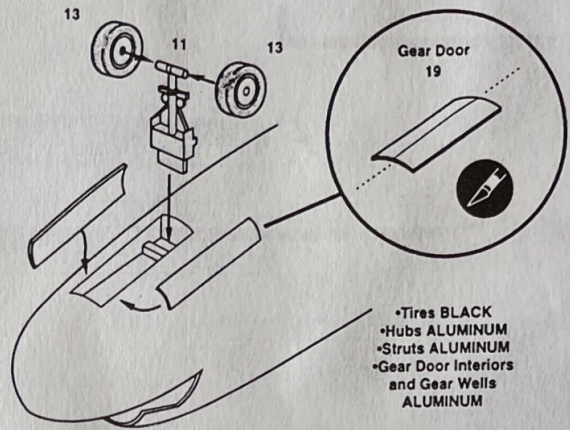

(6) MAIN LANDING GEAR

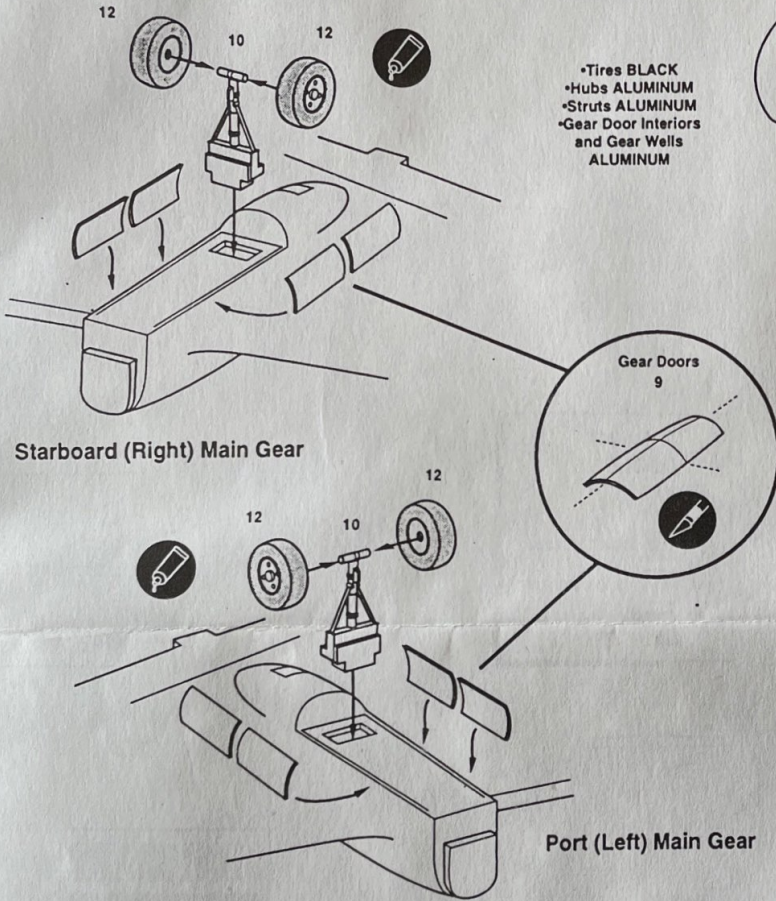

(7) POWERPLANTS

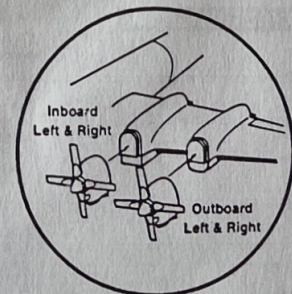
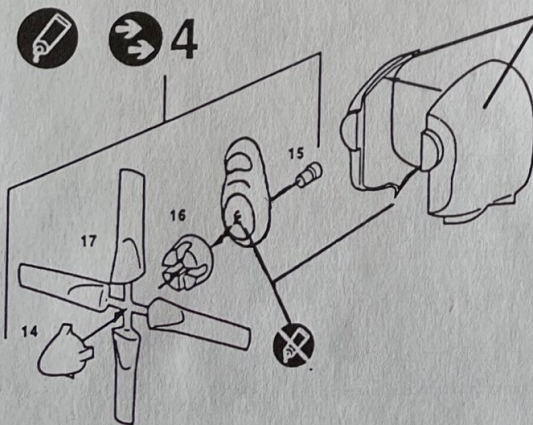

EASTERN AIRLINES ELECTRA

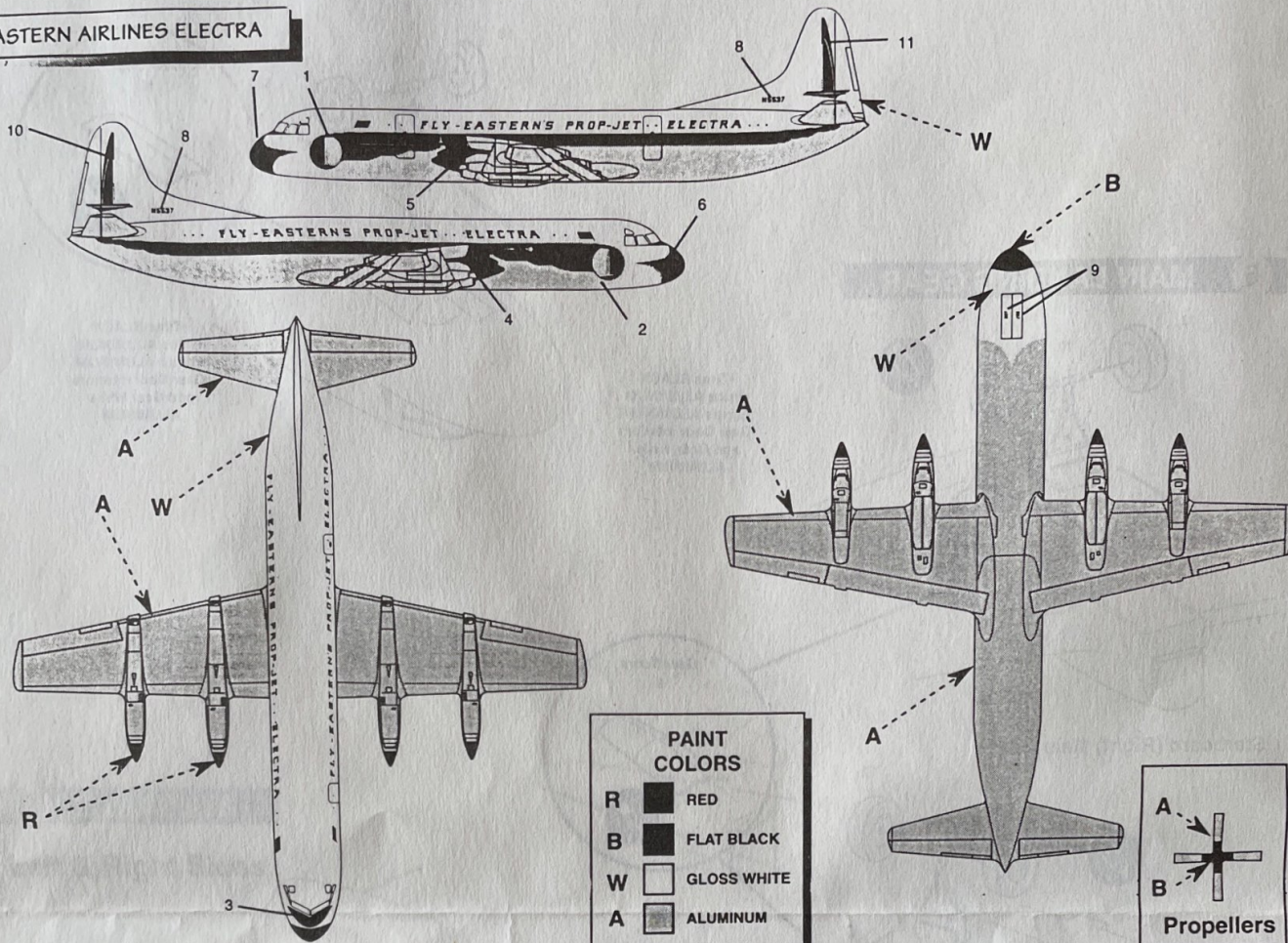

KLM ROYAL DUTCH AIRLINES ELECTRA

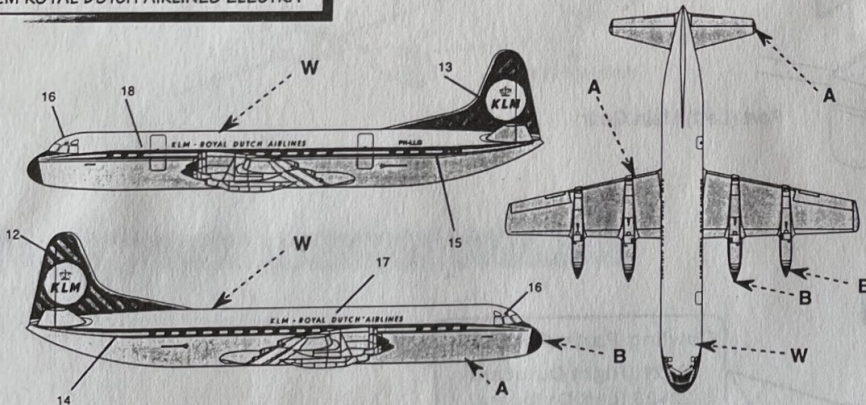

**MINICRAFT
MODEL KITS**

©1998 MINICRAFT MODELS, INC.

PARTS LAYOUT DIAGRAM

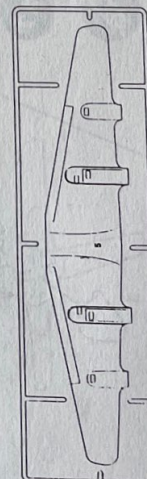
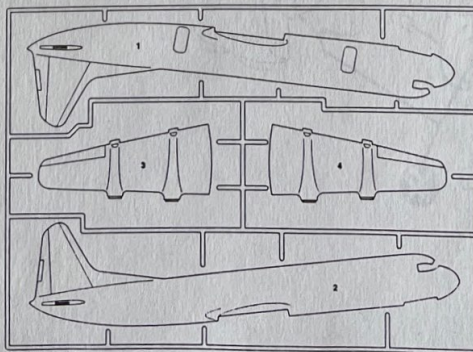
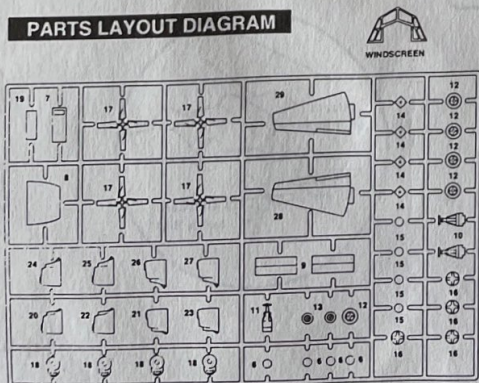

14444-4