



He 111H-20

Германский бомбардировщик II MB

В начале 30-х годов в мире возникла идея создания скоростного бомбардировщика, который мог бы обогнать современные ему истребители-бипланы. Одним из воплощений этой концепции стал двухмоторный бомбардировщик He 111, разработанный германской фирмой Хейнкель Флюгцверке.

С декабря 1941 г. началось производство самолетов He 111H-16 с усиленным вооружением и двигателями жидкостного охлаждения Jumo 211F-2 увеличенной мощности с винтами VS 11, которые имели более широкие деревянные лопасти. Этот вариант мог нести до 3000 кг бомб на внутренней и внешней подвеске.

Стандартизированная модификация He 111H-20 производилась в 1943-1944 г.

Тактико-технические характеристики He 111H-20

Длина, м	16,38
Размах крыла, м	22,50
Взлетный вес, кг	14000
Двигатели	2xJumo 211F-2, 1340 л.с.
Максимальная скорость, км/ч	390
Потолок, м	8500
Дальность, км	2060
Вооружение	1-3x13,2 мм пулемета MG 131, 3x7,92-мм пулемета MG 81Z, до 3000 кг бомб

ВНИМАНИЕ!

Перед сборкой внимательно прочитать руководство по монтажу. Каждая деталь пронумерована. Соблюдать последовательность монтажа. Необходимые рабочие инструменты: нож и напильник для зачистки деталей; резиновая лента, клейкая лента и зажимы для сушки белила для прижигания склеиваемых деталей; Детали из пластика очистить в растворе мягкого моющего средства и высушить на воздухе для того, чтобы краска и переводные картинки лучше прилипали. Перед приклеиванием проверить, подходят ли детали; клей наносить экономно. Хром и краску удалить с поверхностей склеивания. Небольшие детали покрасить перед тем, как они будут удалены из рамок. Краску необходимо хорошо просушить, только после этого продолжать сборку. Каждую соответствующую переводную картинку отдельно вырезать и примерно на 20 секунд опустить в теплую воду. На обозначенном месте картинку отделить от бумаги и прижать промокающей бумагой.

He 111H-20

WWII German Bomber

In the beginning of 30s it was appeared in the world an idea of high-speed bomber that could outstrip contemporary fighters. One of the objectifications of this conception became the twin-engine bomber He 111 designed by a German Heinkel Flugzeugwerke AG company.

Since the December of 1942 it were produced He 111H-16 planes with liquid-cooled Jumo 211F-2 engines of increased power, with VS 11 wooden wider horde propellers and more powerful armament. This variant could carry up to 3000 kg bombs internally and externally.

The improved standardized modification Heinkel 111H-20 was produced in 1943-1944.

Tactical and Technical Specifications of He 111H-20

Length, m	16,38
Span, m	22,50
Start weight, kg	14000
Engines	2xJumo 211F-2, 1340 hp
Max. Speed, km/h	390
Service ceiling, m	8500
Range, km	2060
Armament	1-3x13,2 mm MG 131, 3x7,92 mm MG 81Z, bomb load - up to 3000

CAUTION!

Read the instructions thoroughly prior to assembly. Each component is numbered. Adhere to specified sequence of assembly. Tools required: knife and file for removal of components from frame; rubber bond, adhesive tape and clothes pegs for clamping components together after applying adhesive. Clean plastic components in a mild detergent solution and allow to air-dry so that paint and transfers adhere better. Prior to applying adhesive, check to see whether the components fit together; apply adhesive sparingly. Remove chrome and paint from the contact surfaces. Paint small components before removing them from the frame. Allow paint to dry well, and only then continue to assemble. Cut out each transfer individually and immerse in warm water for approx. 20 seconds. Slide transfer off paper and into designated position, then press on with blotting paper.

ИСПОЛЗУЕМЫЕ КРАСКИ / USED COLORS:

	Revell	Tamiya		
A	108	XF1	Черный, матовый	Flat Black
B	105	XF2	Белый, матовый	Flat White
C	115	XF3	Желтый, матовый	Flat Yellow
D	140	XF27	Черно-зеленый RLM 70	Schwarzgrun RLM70
E	139	XF61	Темно-зеленый RLM71	Dunkelgrun RLM71
F	149	XF23	Голубой RLM65	Hellblau RLM65
G	177	XF84	Черно-серый, матовый	Schwarzgrau RLM66
H	145	XF22	Серо-зеленый RLM02	Grau RLM02

	Revell	Tamiya		
J	199	XF16	Алюминий, полуматовый	Aluminium
K	191	X11	Сталь	Steel
L	109	X10	Темный металл	Gun Metal
M	183	XF64	Ржавчина	Rust
N	731	X27	Красный, прозрачный	Clear Red
P	161	X25	Зеленый, прозрачный	Clear Green
R	330	XF7	Красный, матовый	Flat Red

01 СТАДИЯ СБОРКИ
ASSEMBLY STEP

03 СБОРОЧНАЯ ЕДИНИЦА
ASSEMBLY UNIT

A ИСПОЛЗУЕМАЯ КРАСКА
USED COLOR

ПРОСВЕРЛИТЬ
OPEN HOLE

НЕ КЛЕИТЬ
DO NOT CEMENT

x2 СДЕЛАТЬ ДВЕ ДЕТАЛИ
MAKE 2 PCS

СДЕЛАТЬ САМОМУ
SCRATCH BUILD

? ПРОИЗВОЛЬНЫЙ ВЫБОР
OPTIONAL

ПРИ СБОРКЕ НЕ ИСПОЛЗУЕТСЯ
PARTS NOT FOR USE

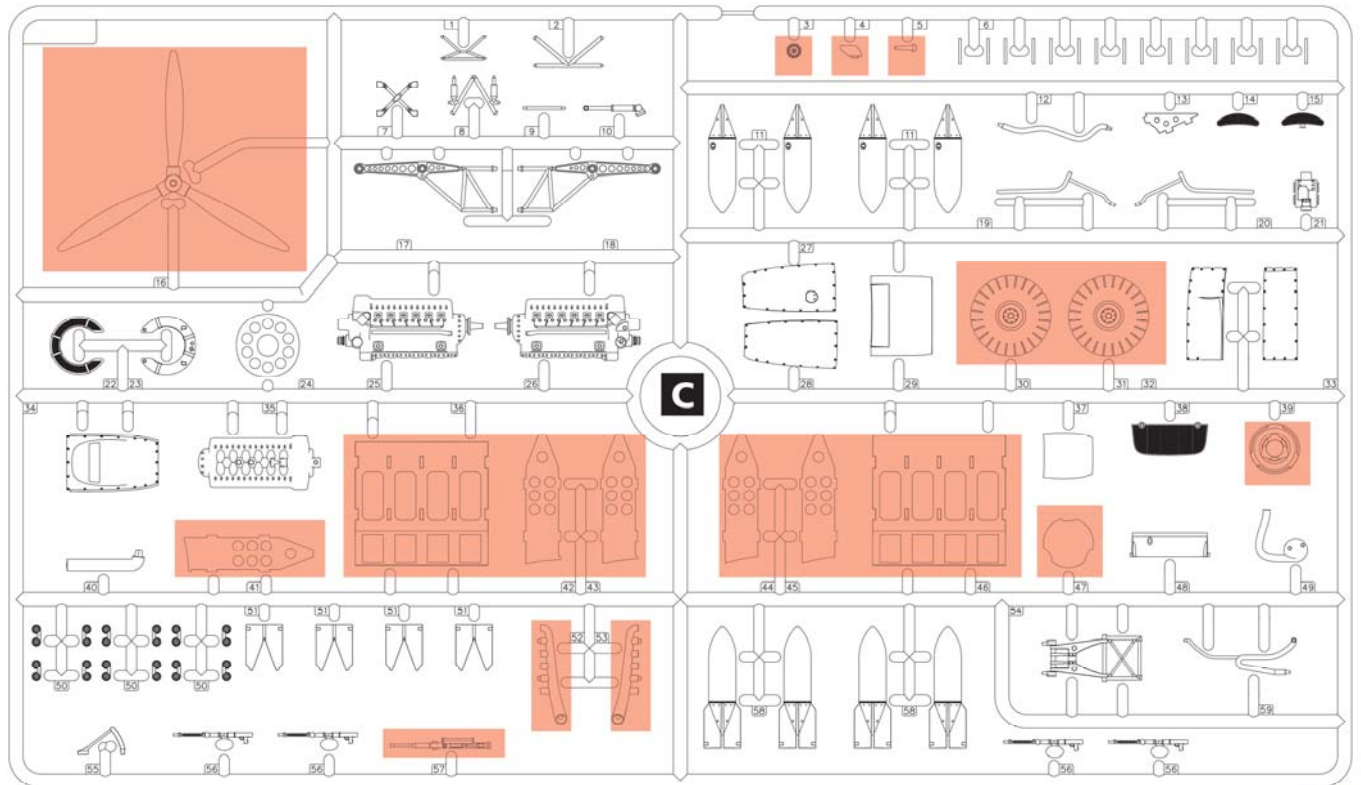
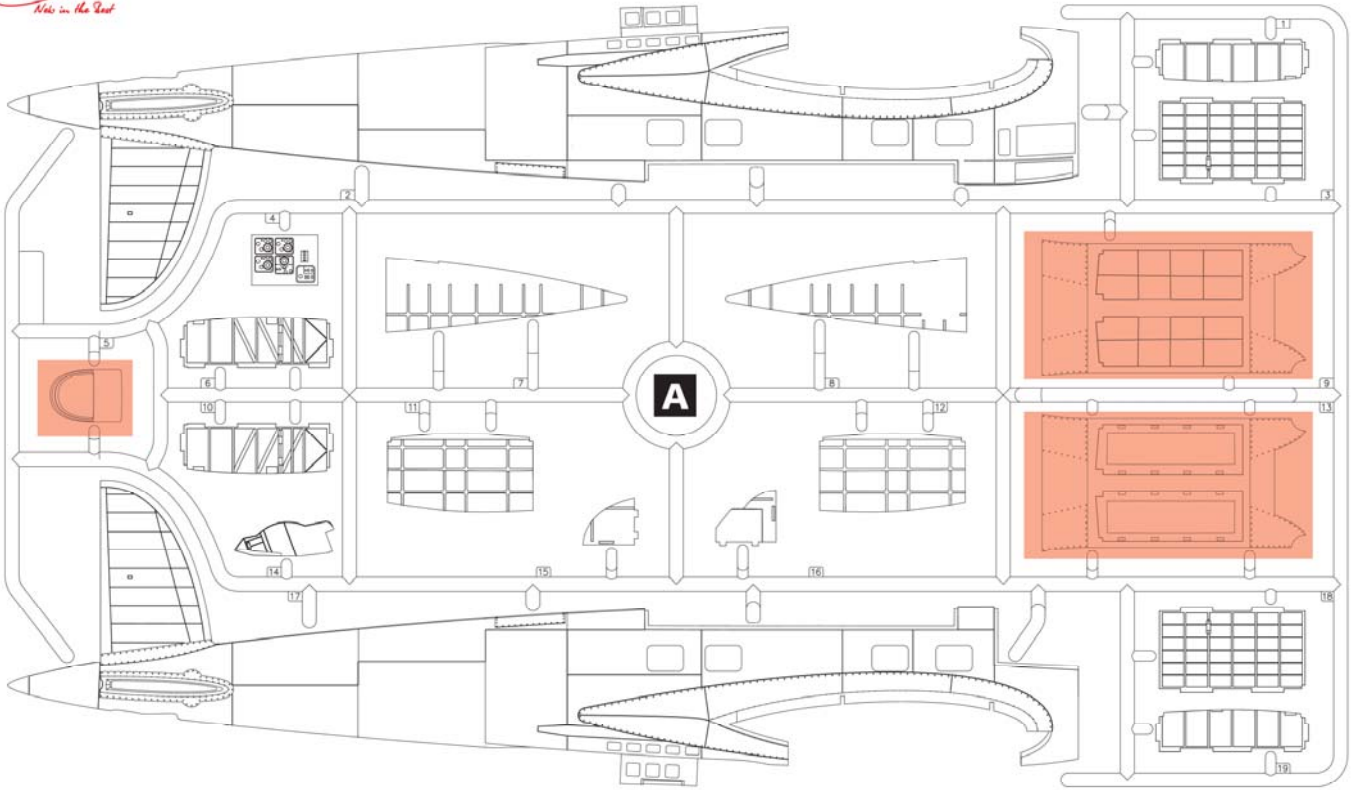

x2

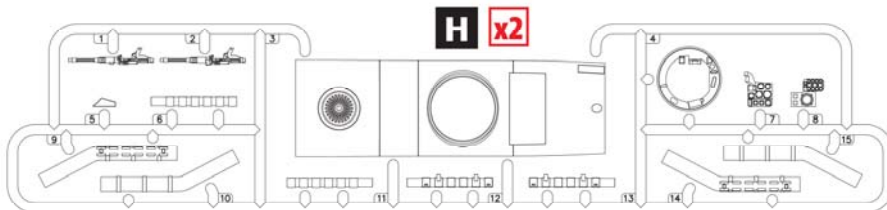

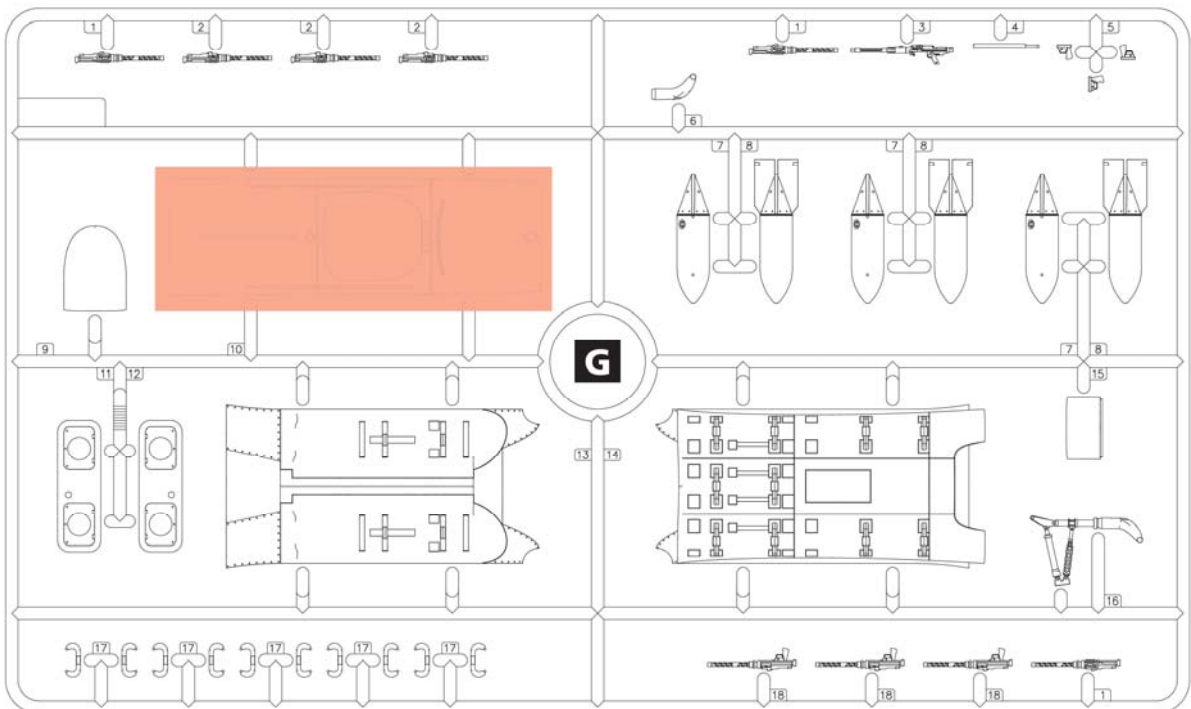
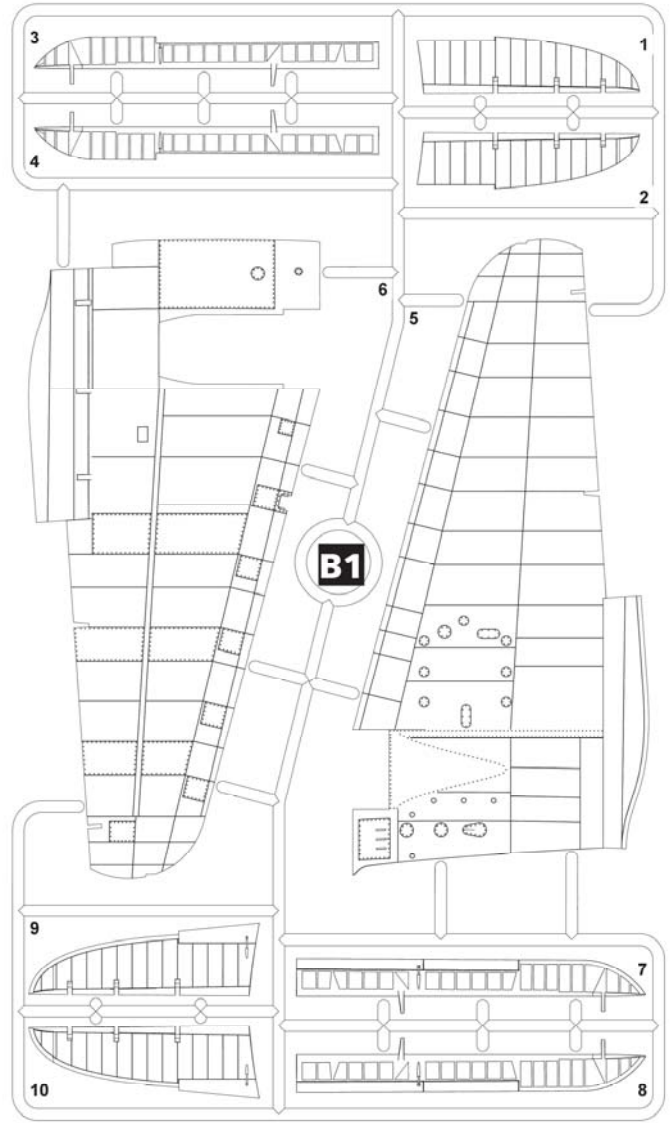
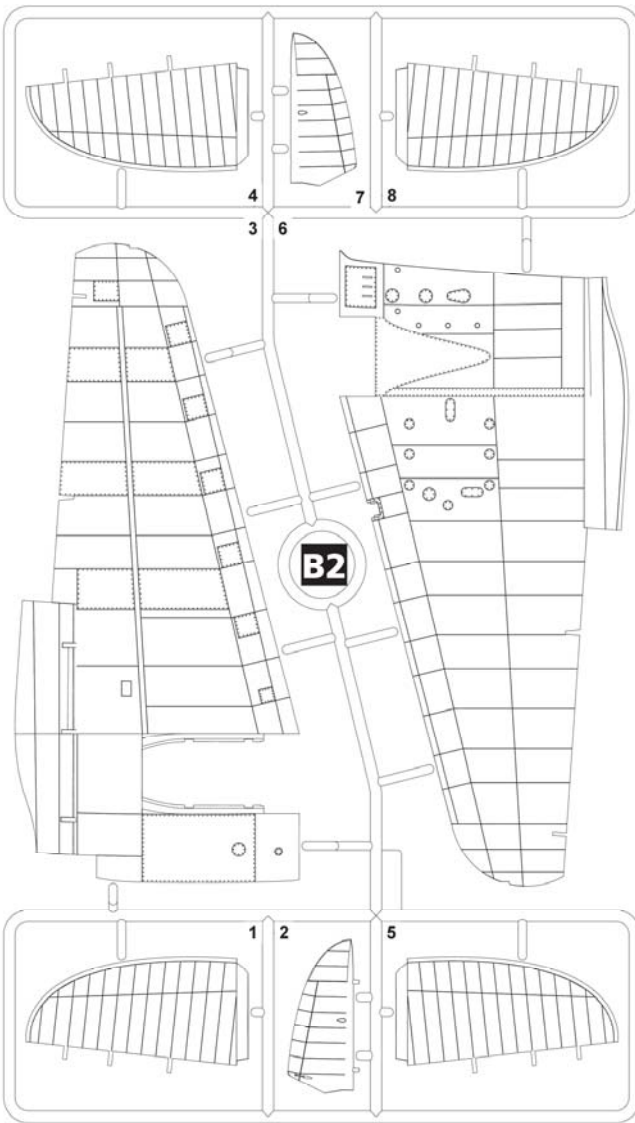

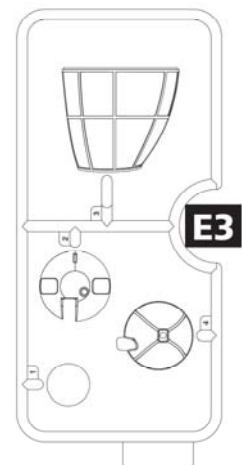
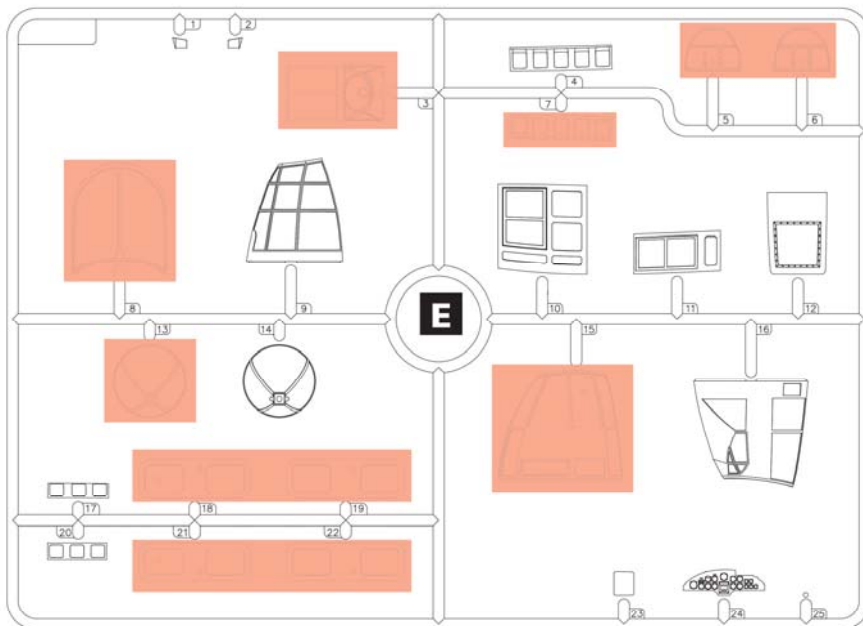
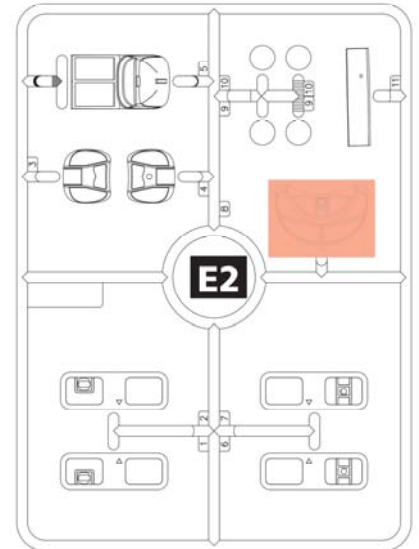
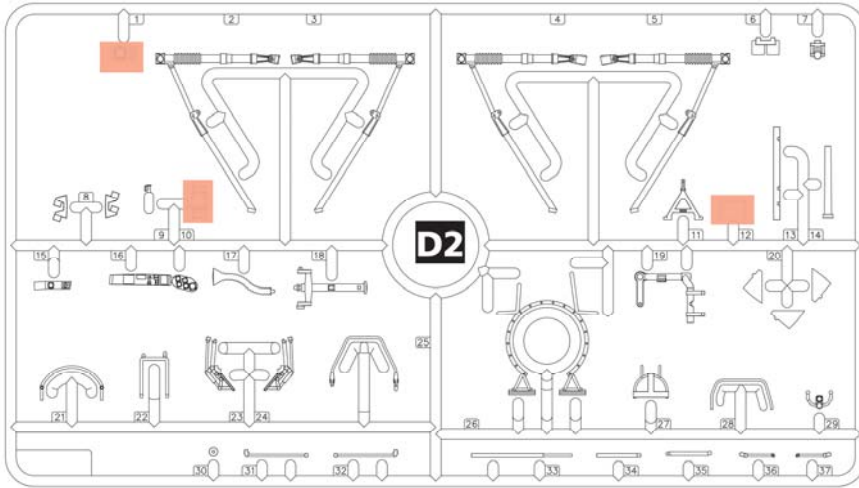
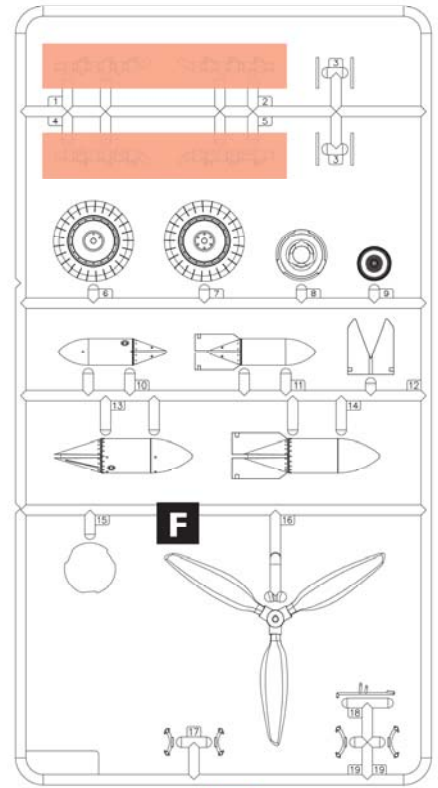
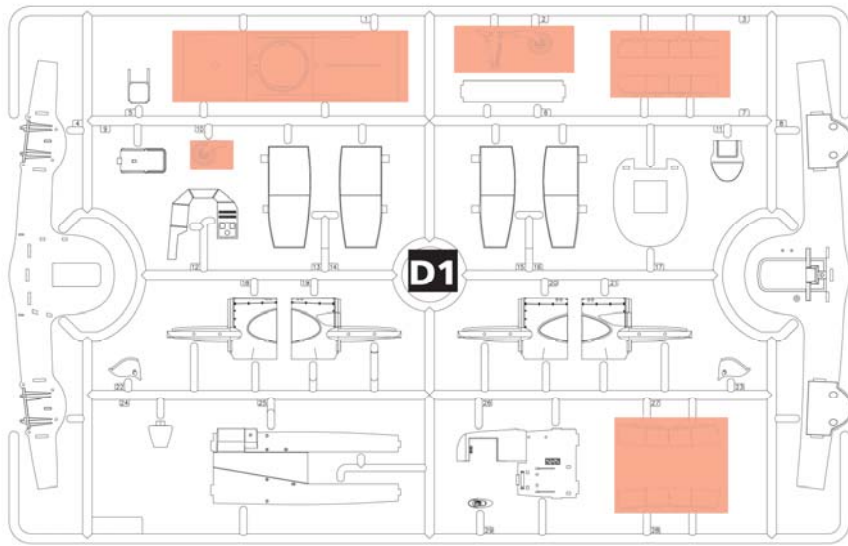

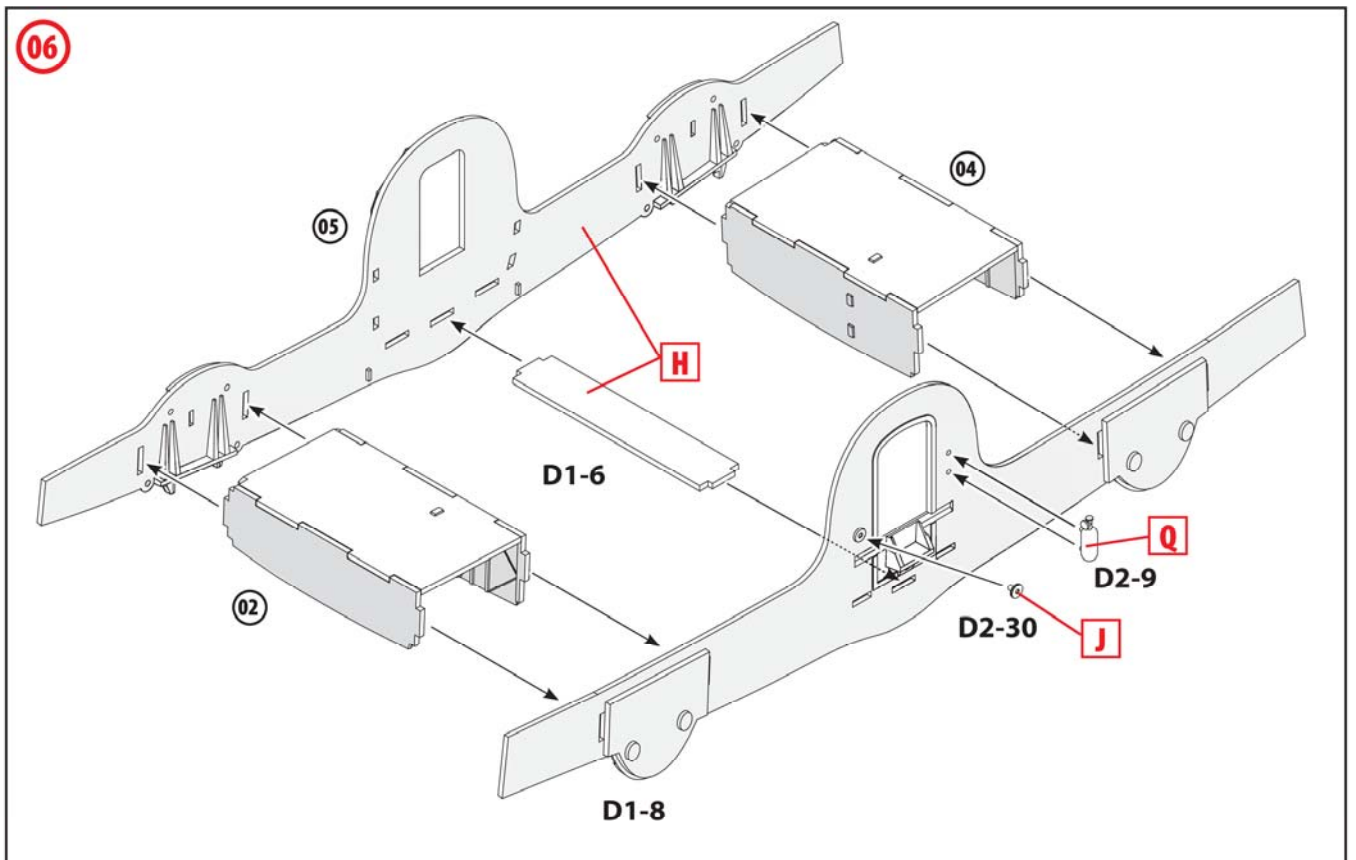
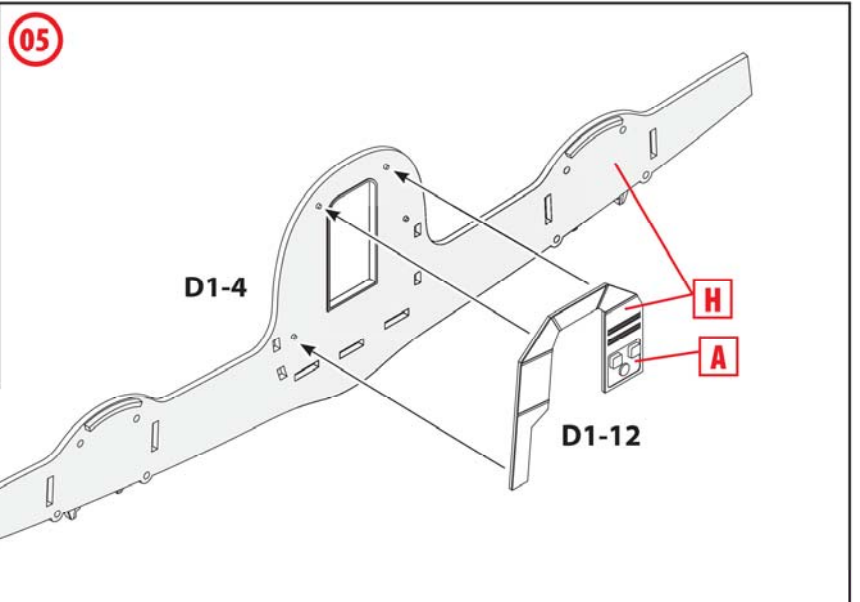
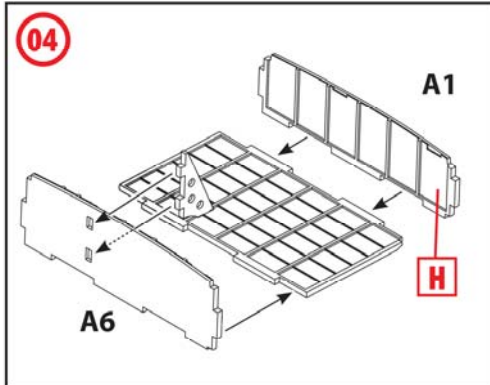
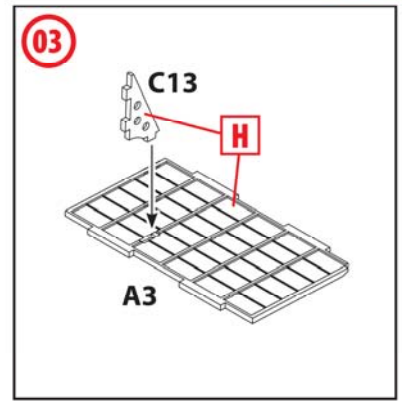
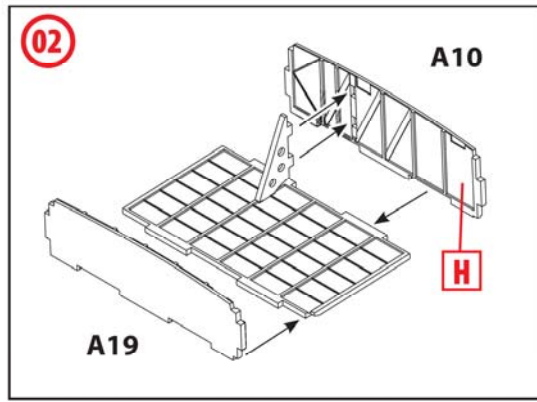
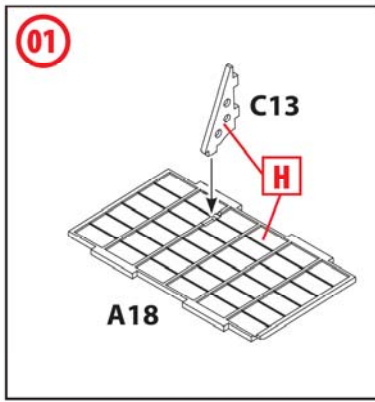

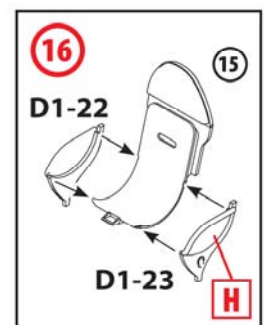
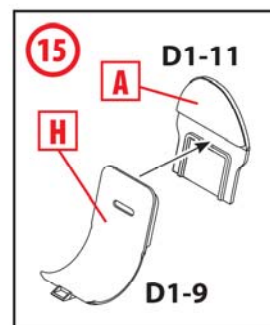
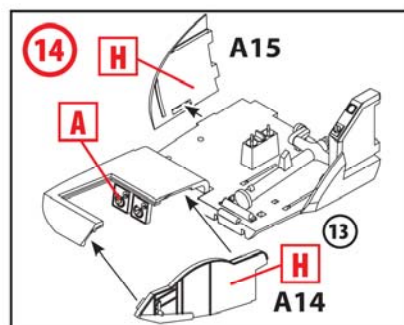
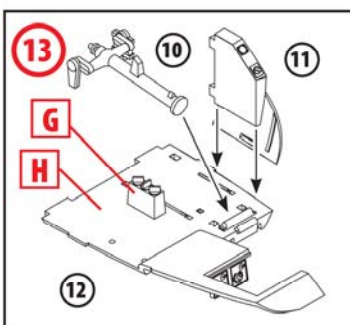
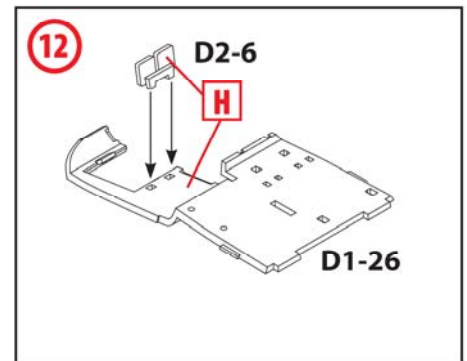
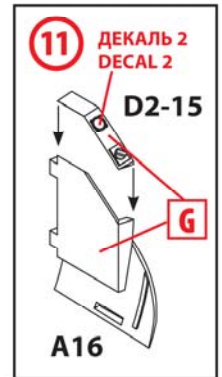
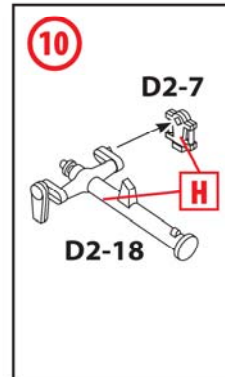
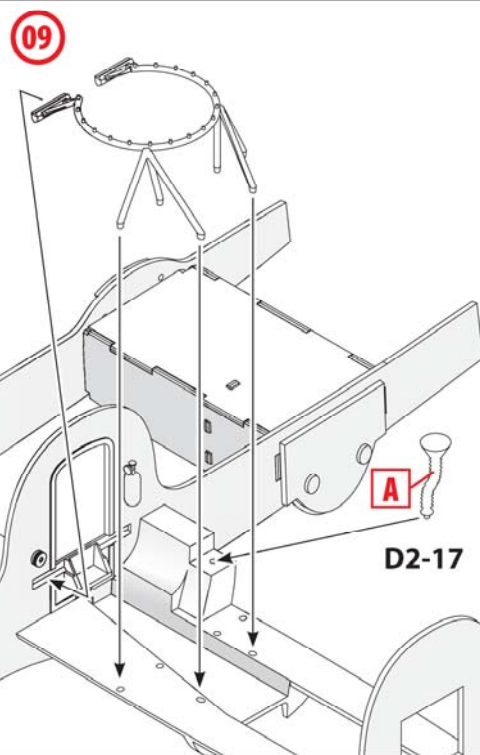
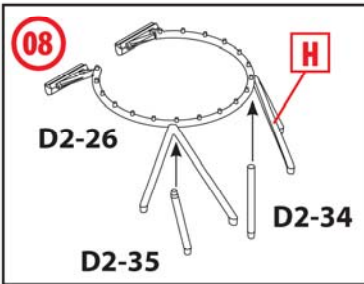
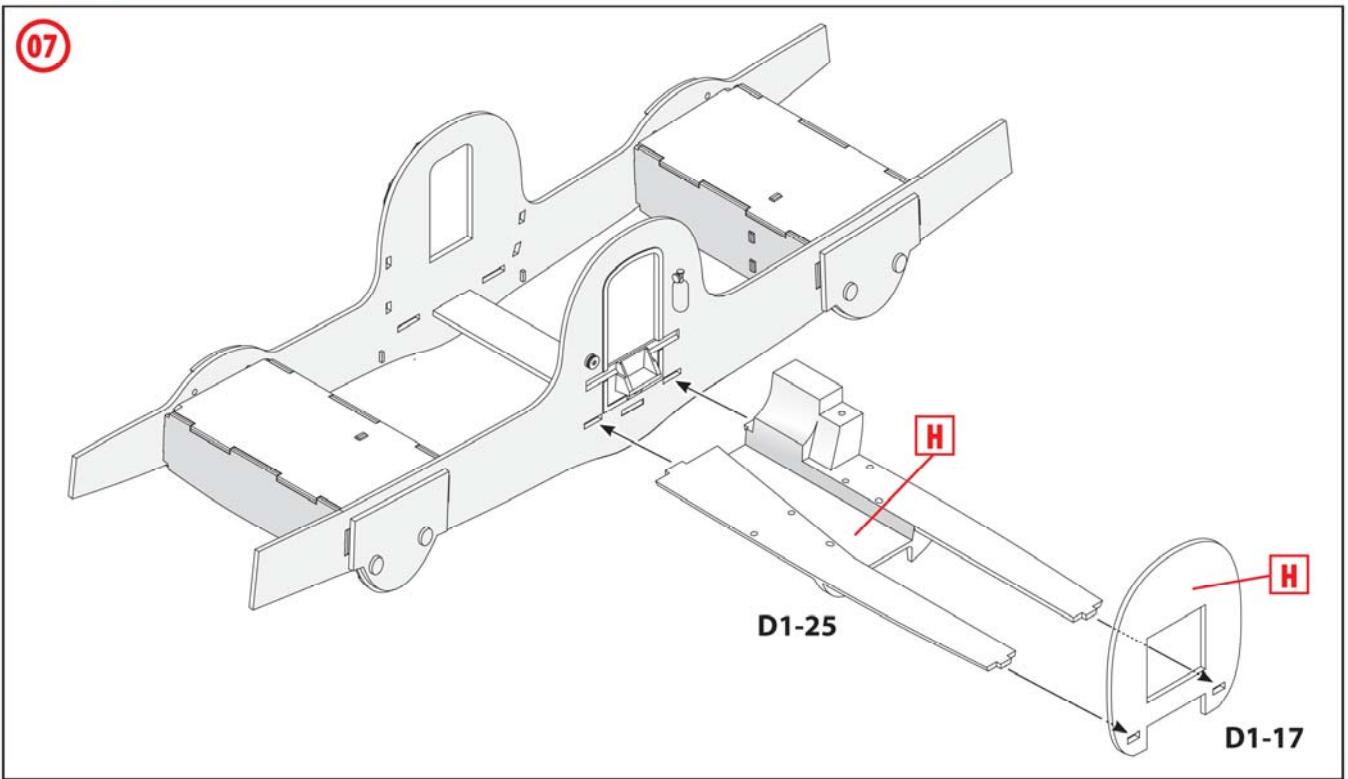

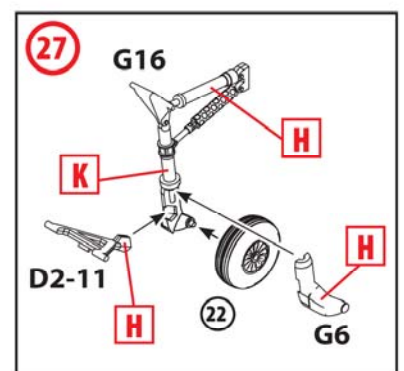
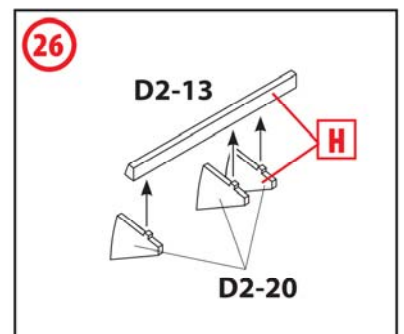
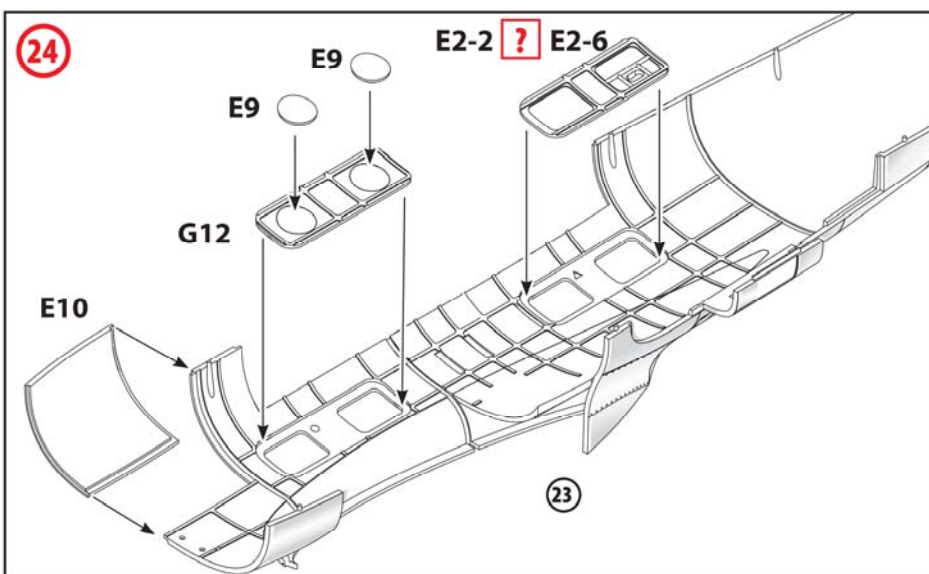
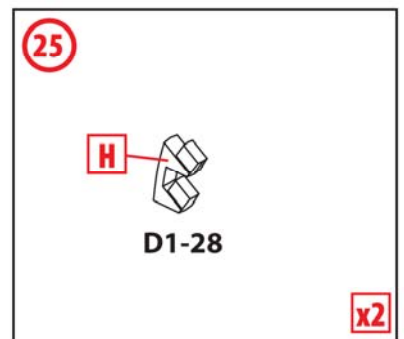
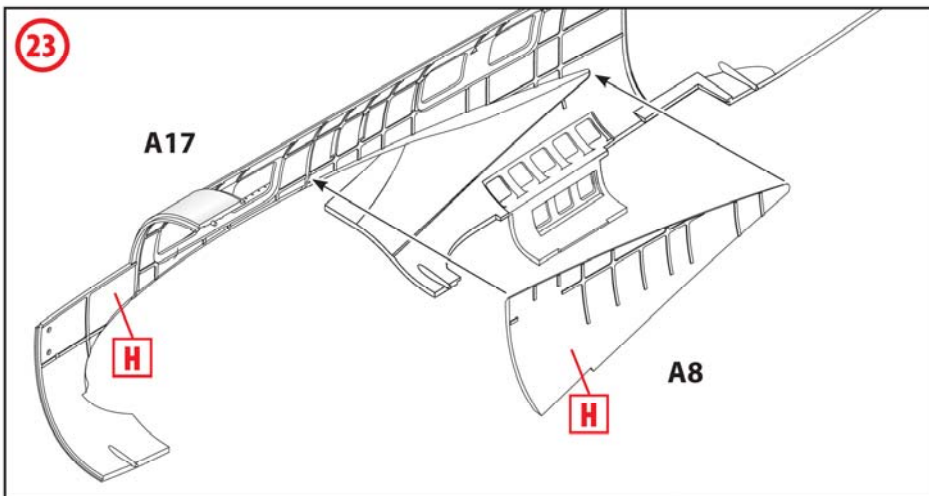
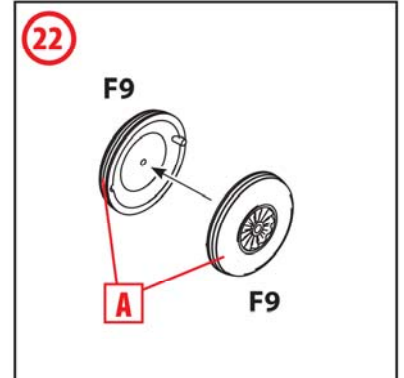
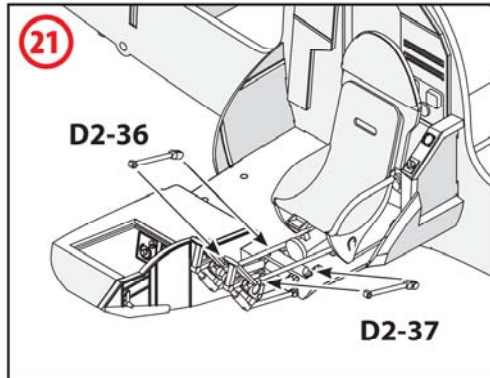
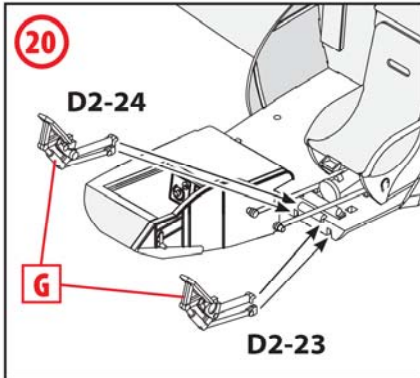
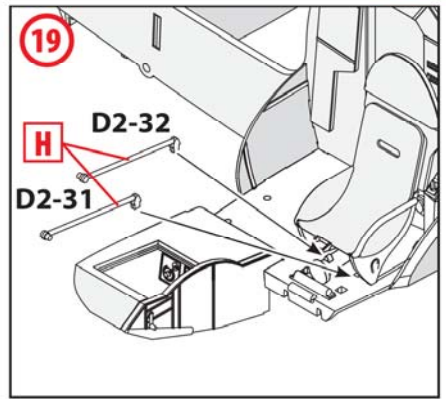
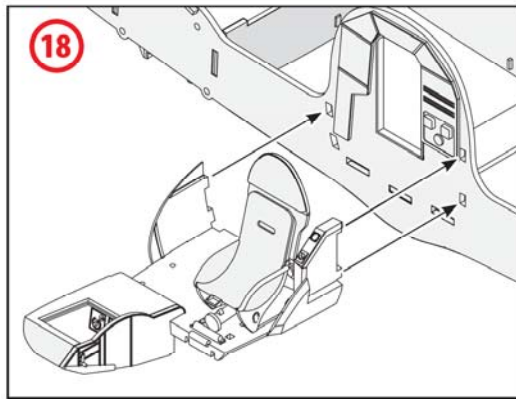
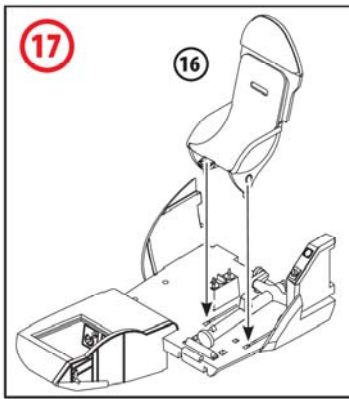

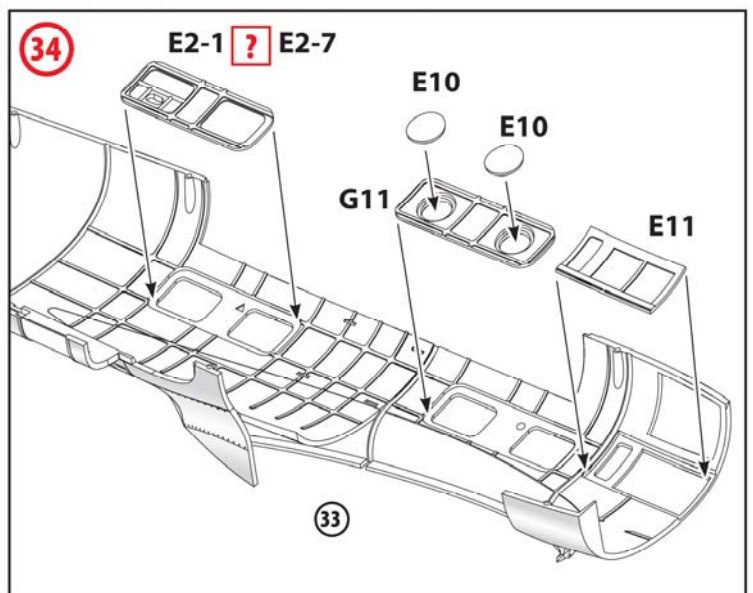
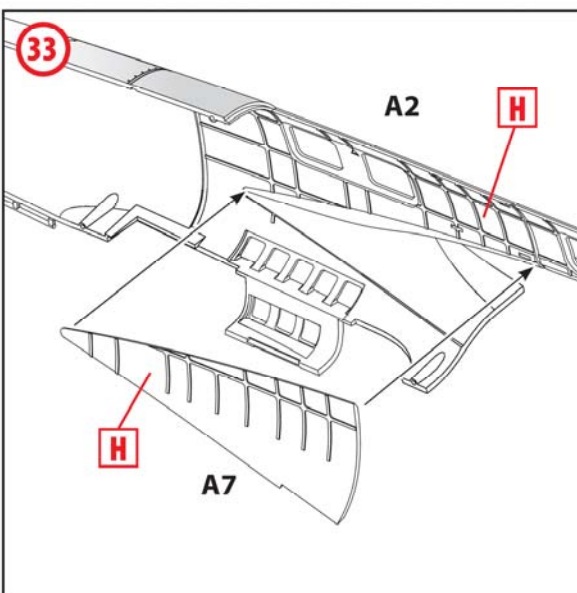
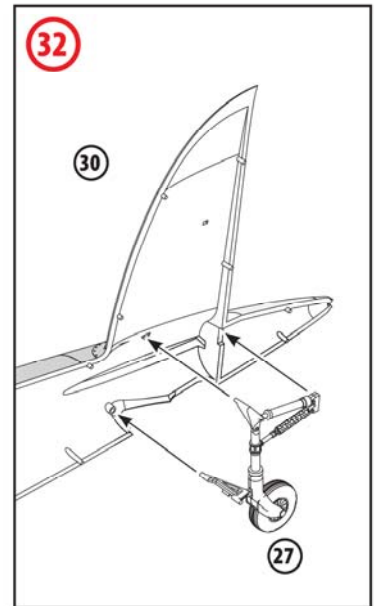
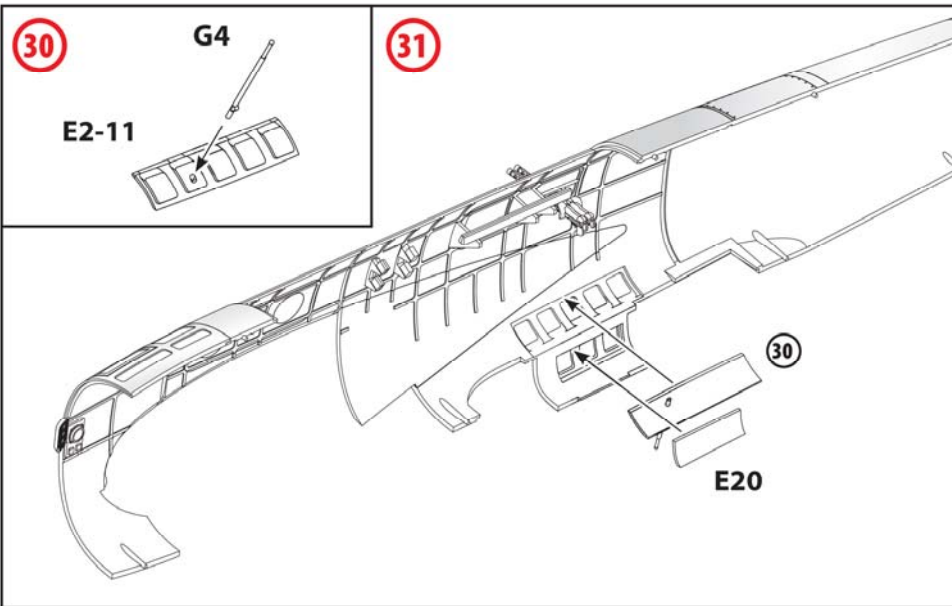
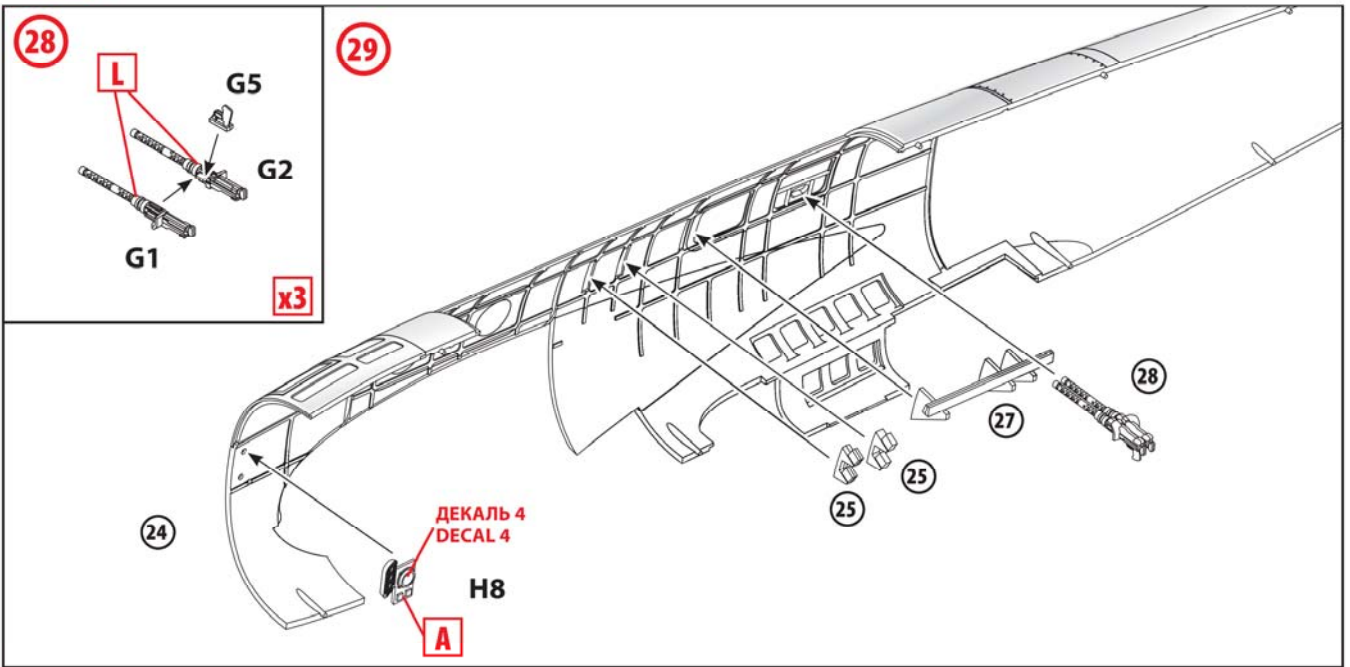

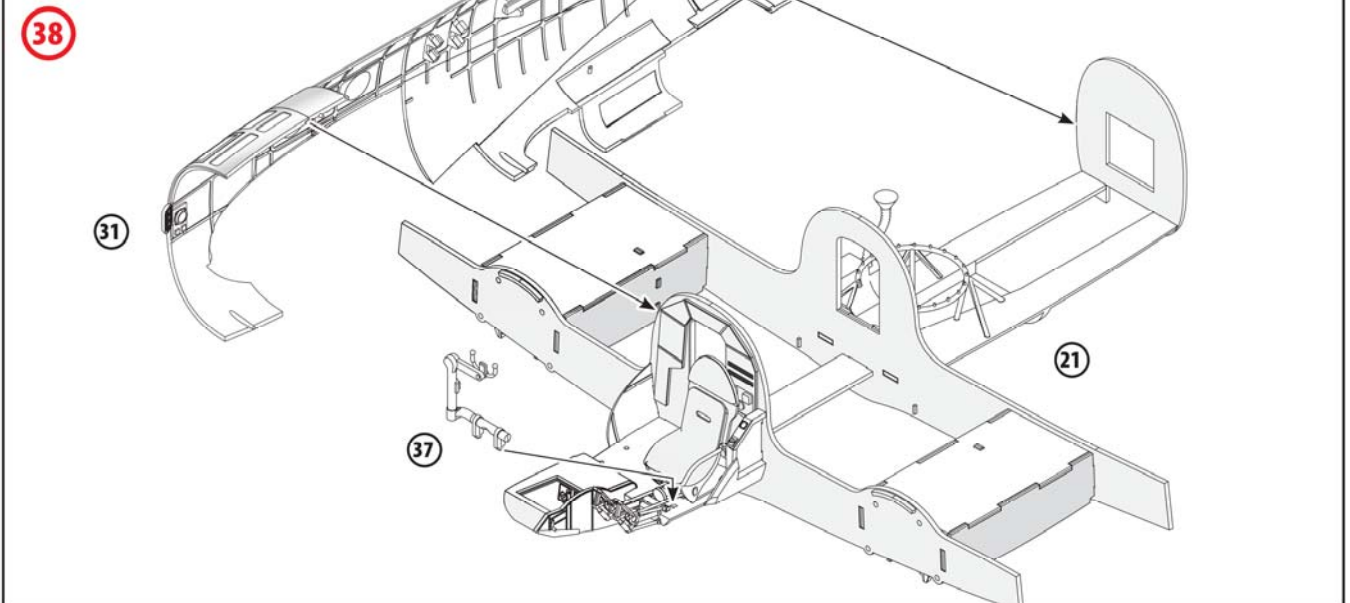
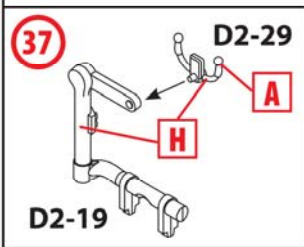
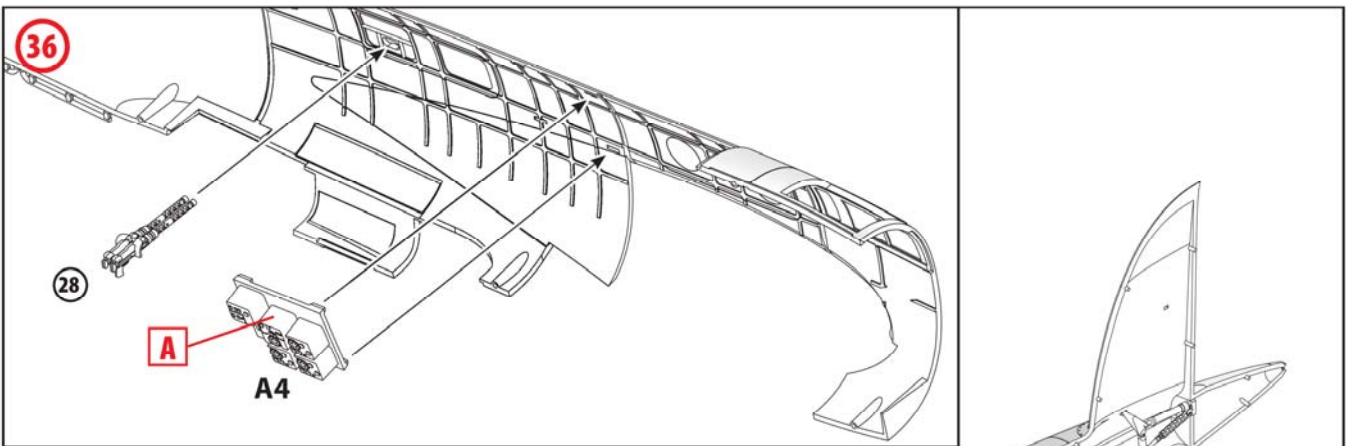
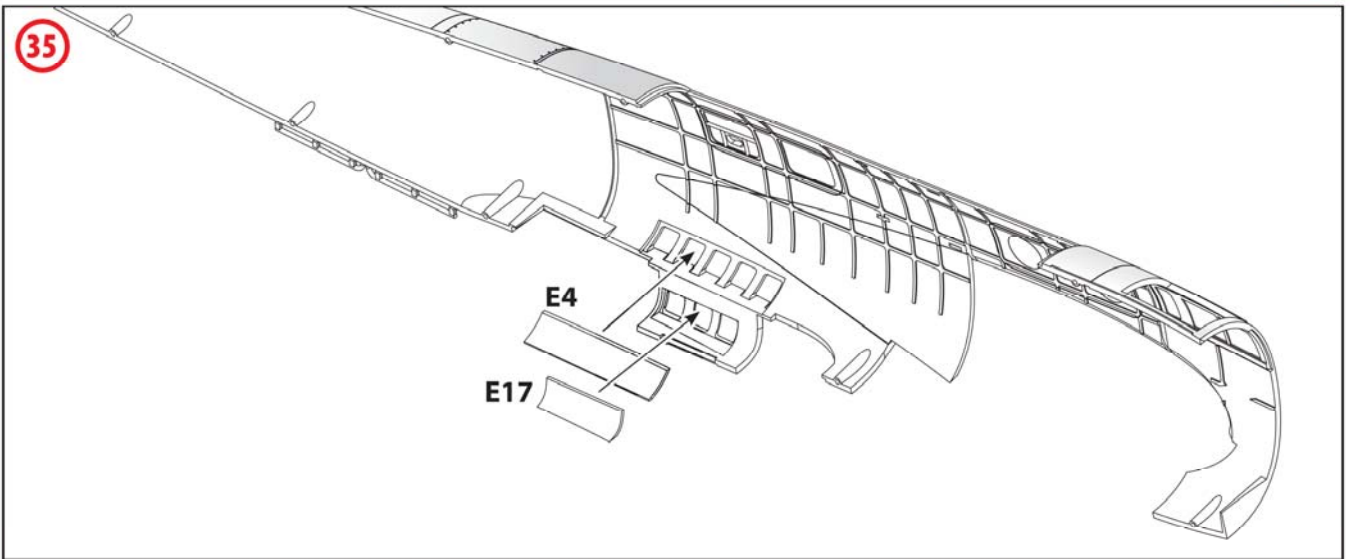

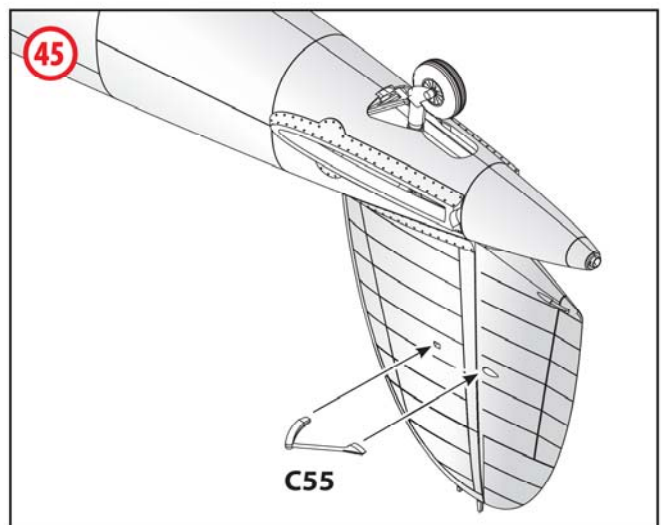
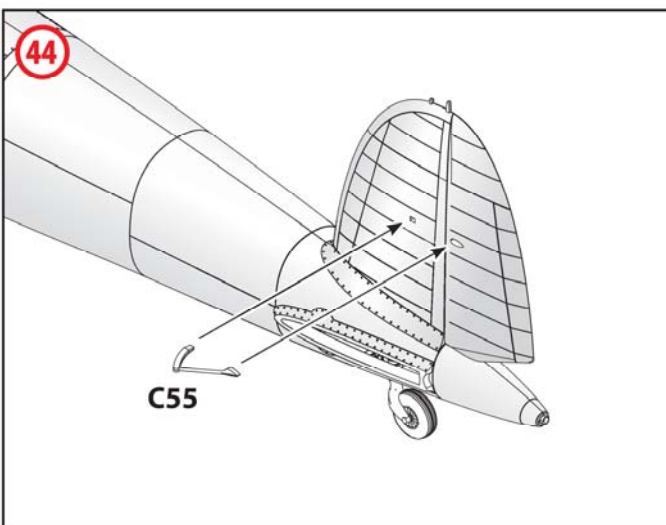
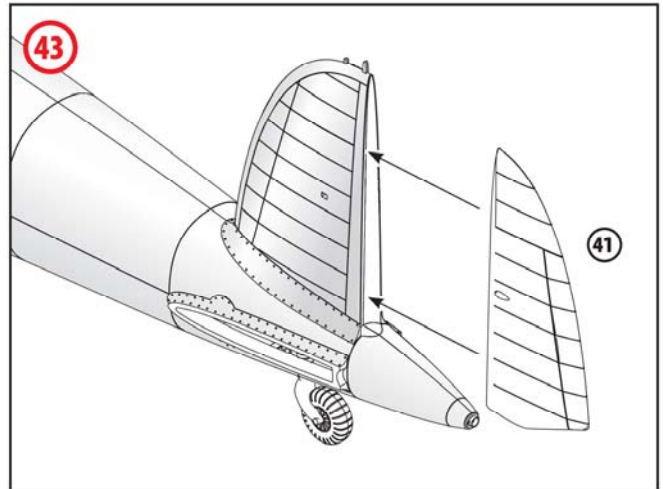
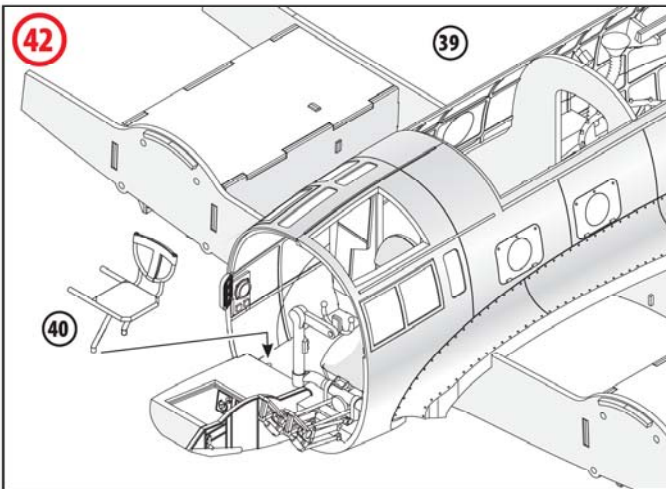
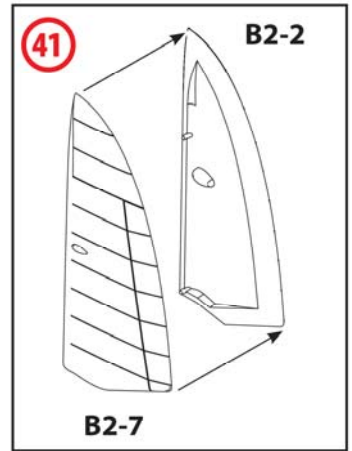
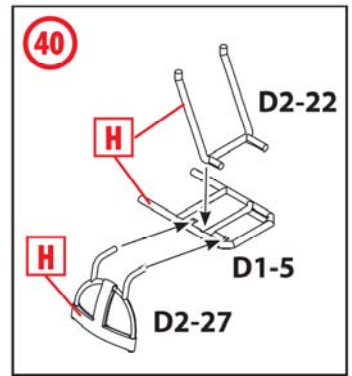
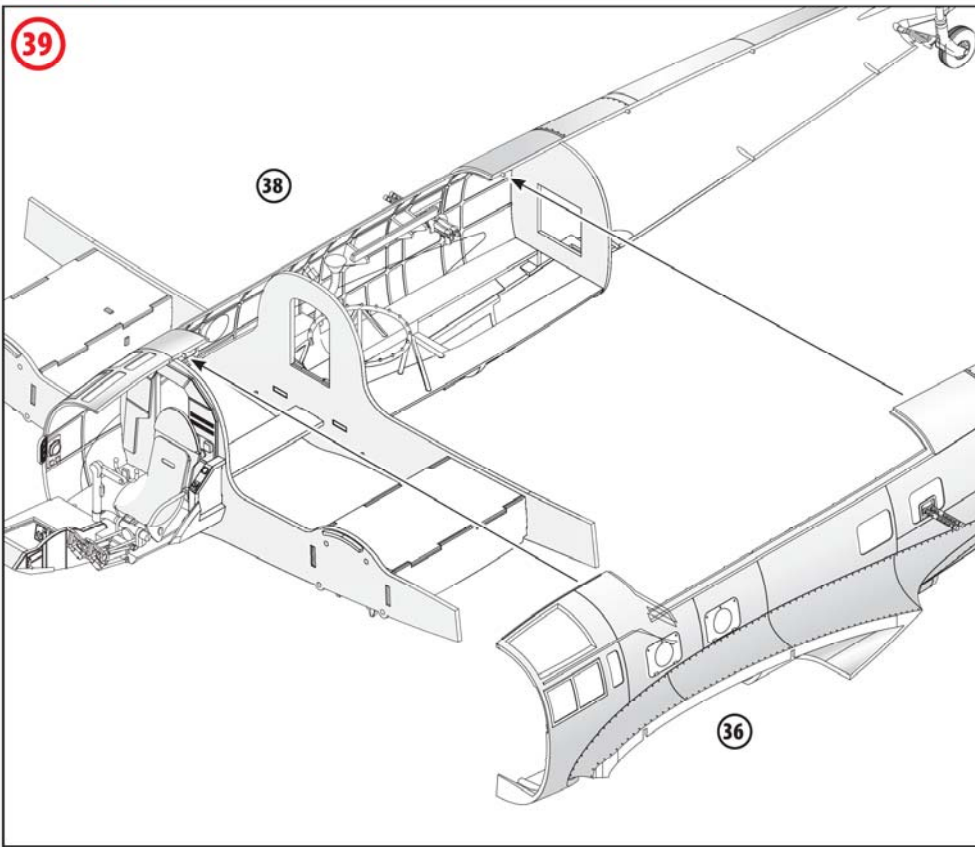

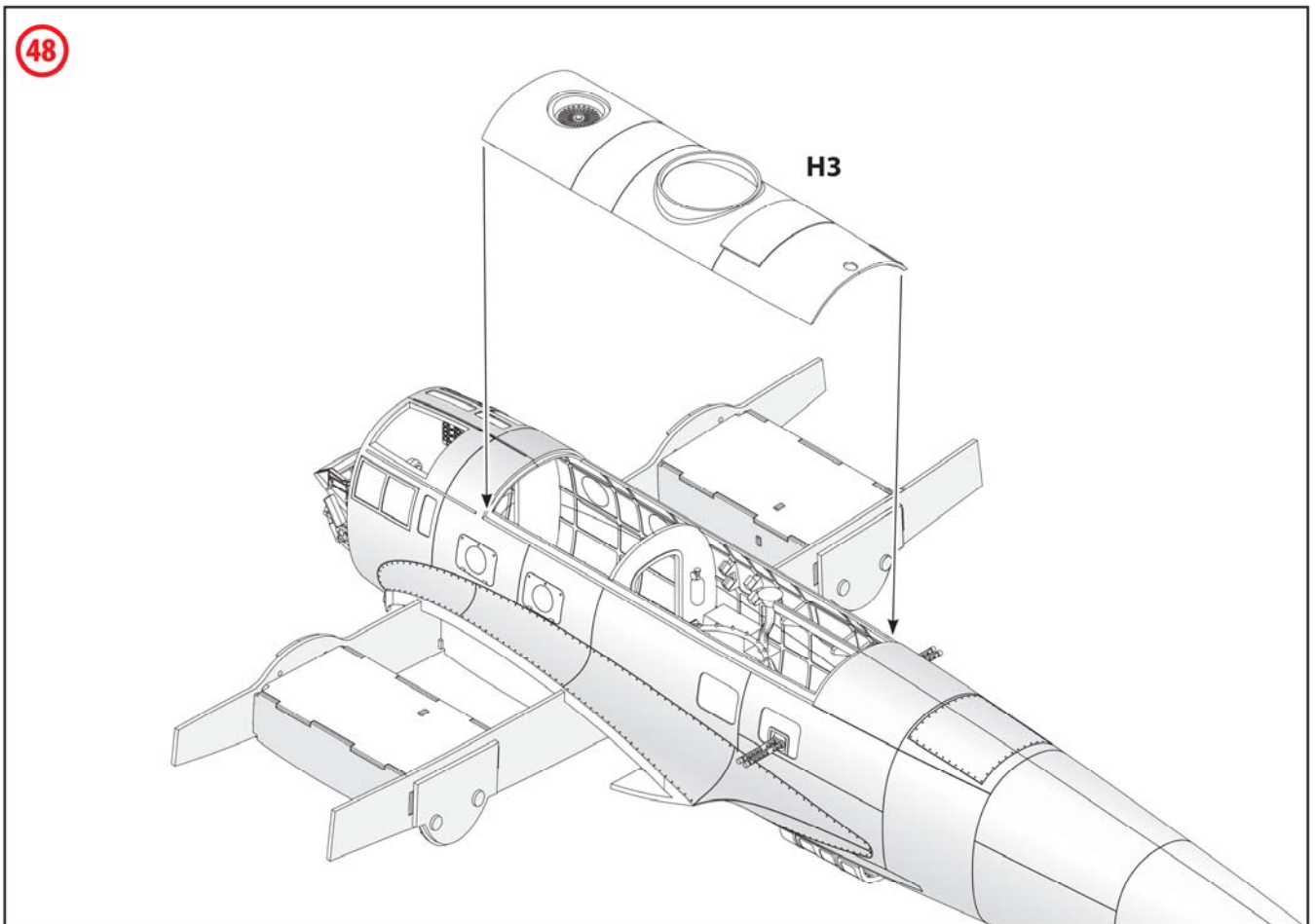
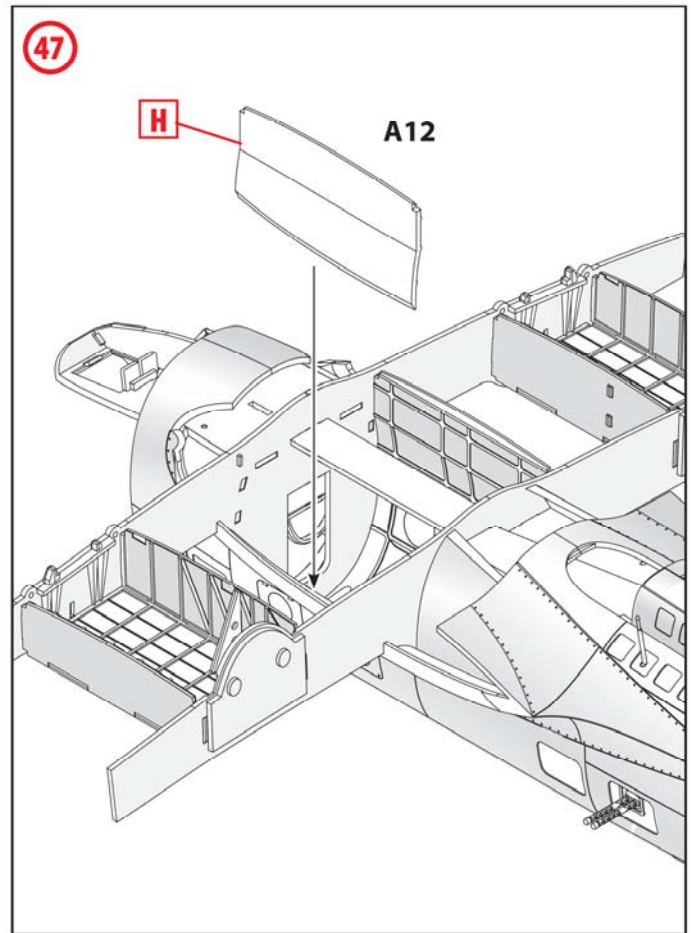
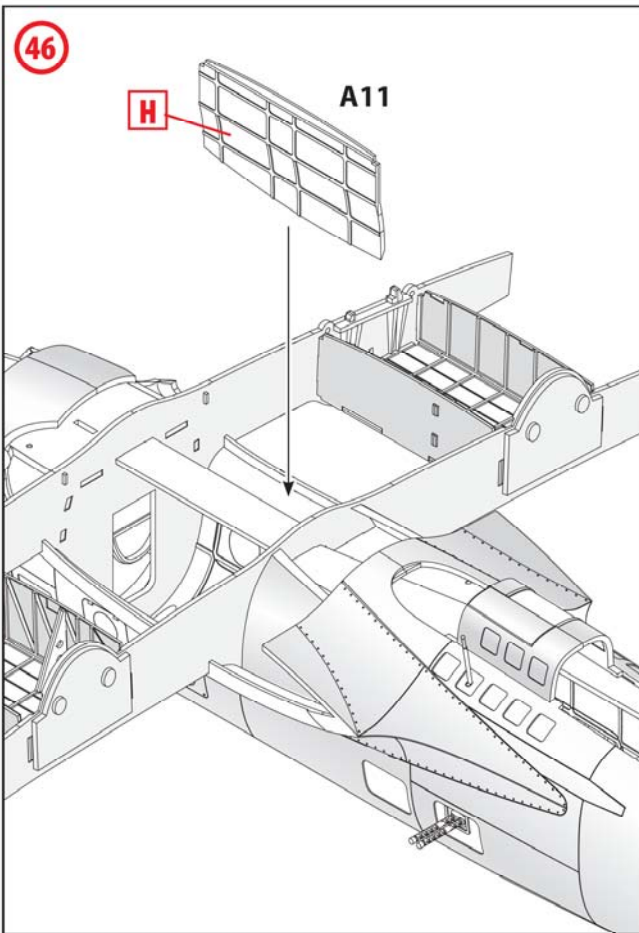

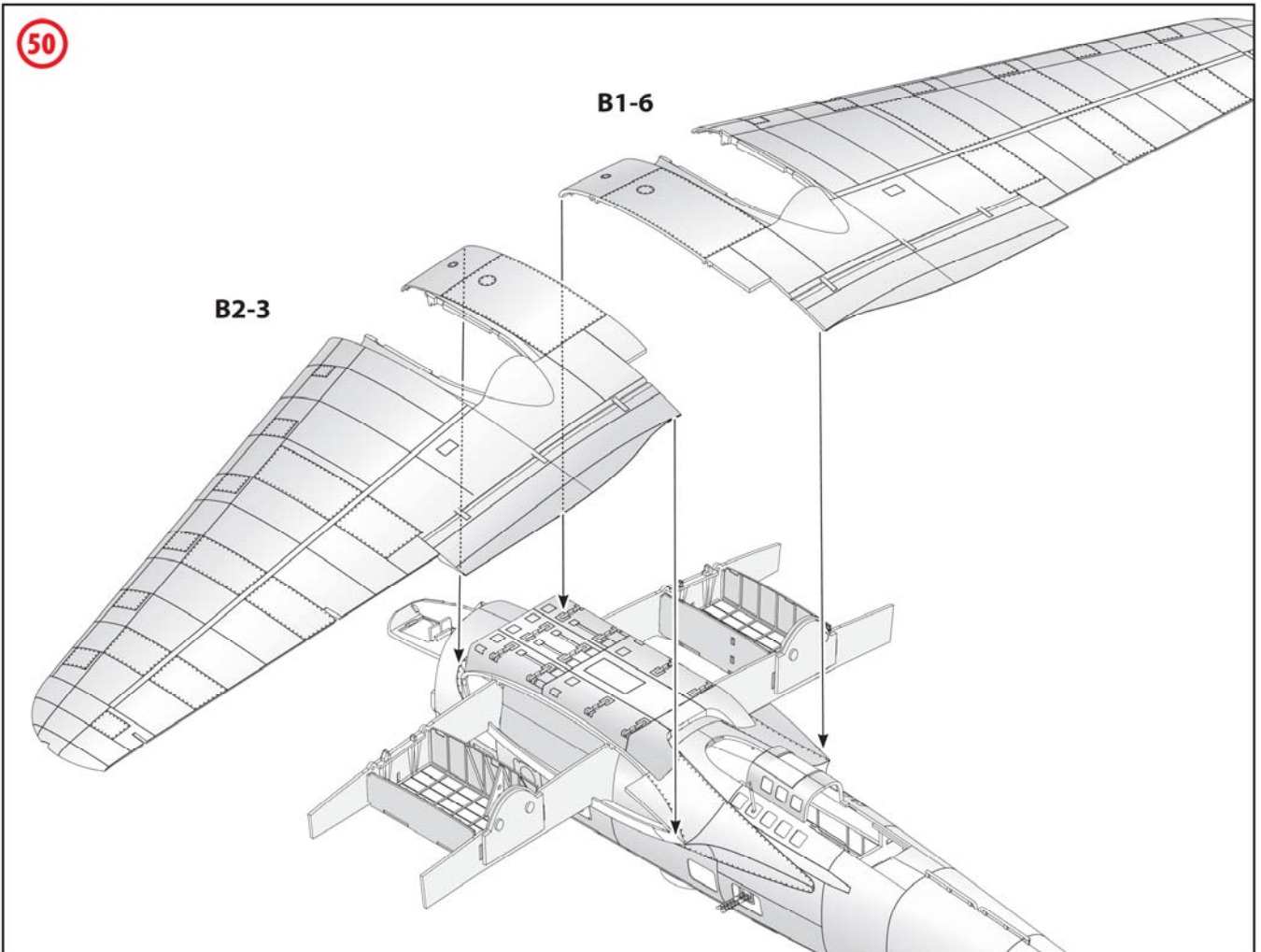
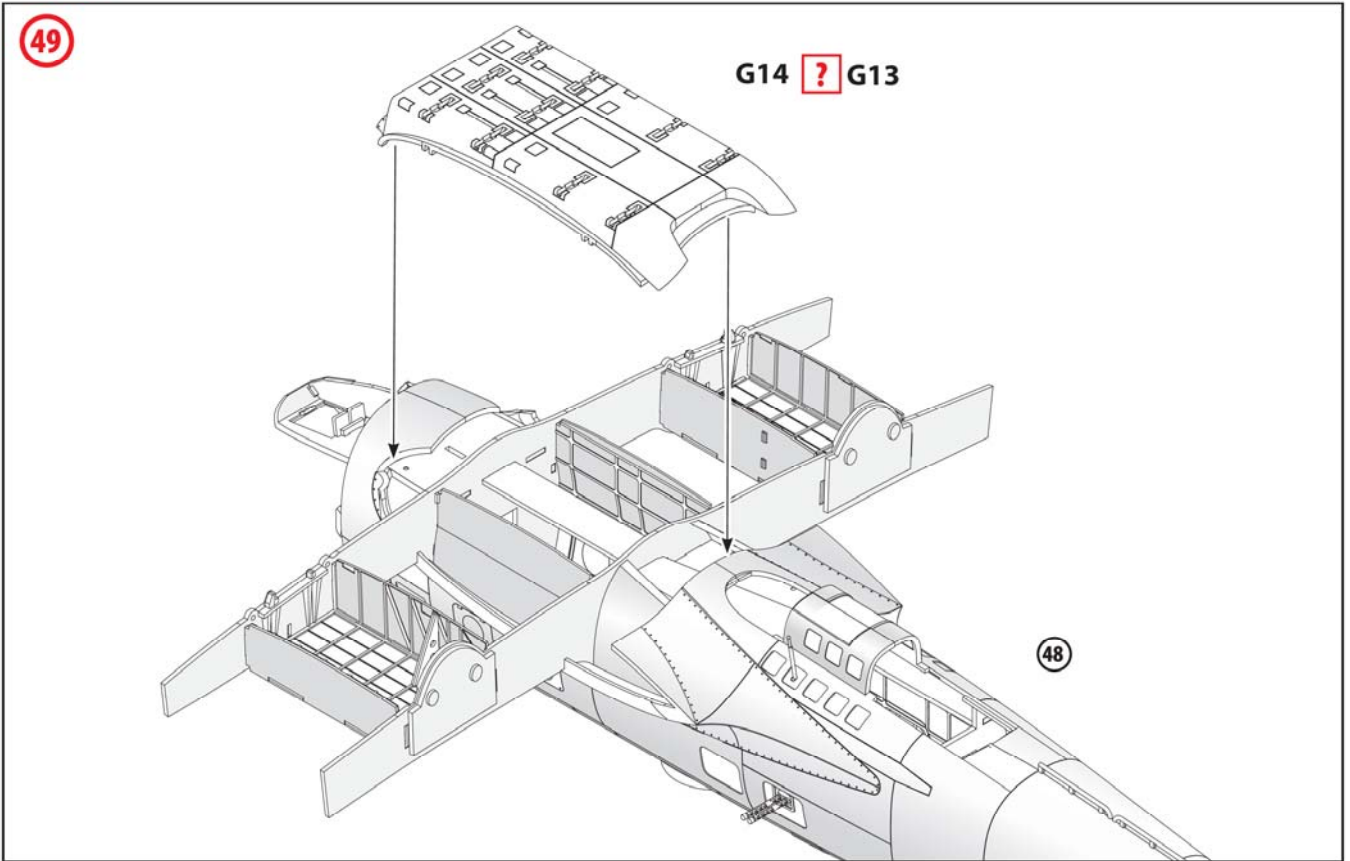

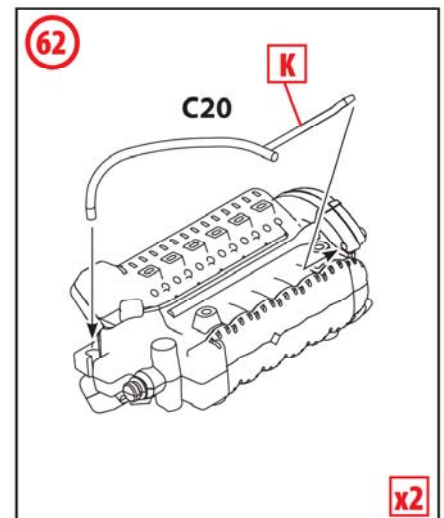
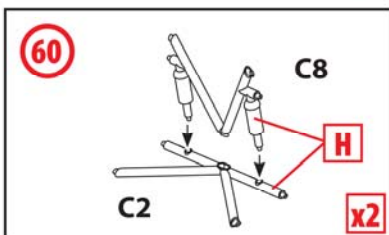
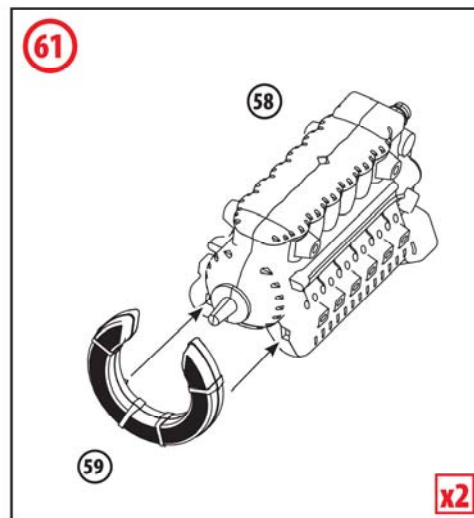
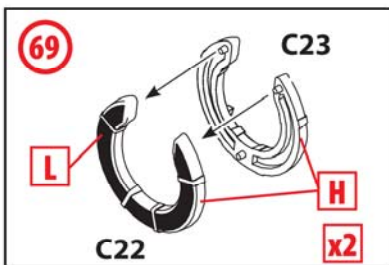
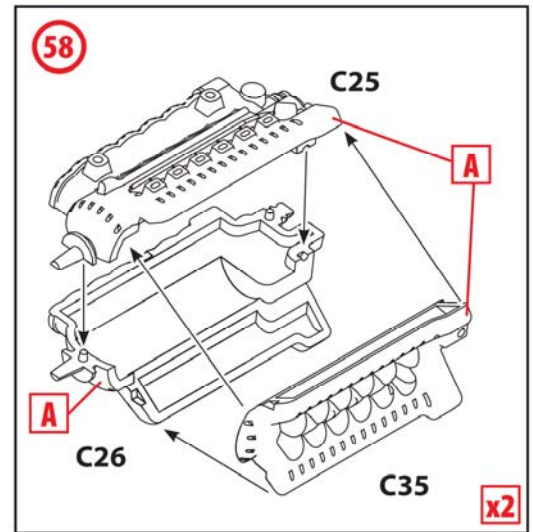
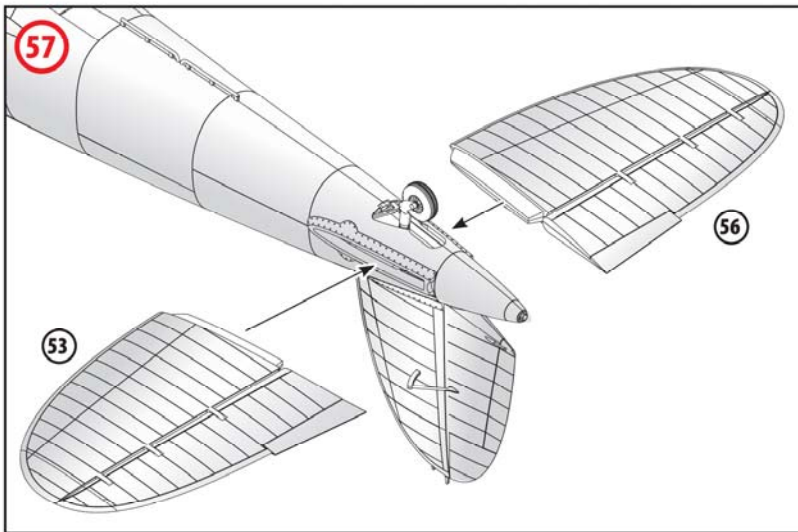
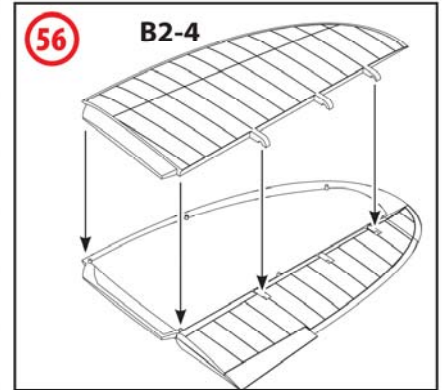
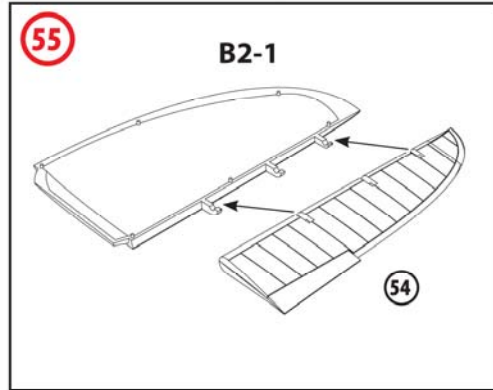
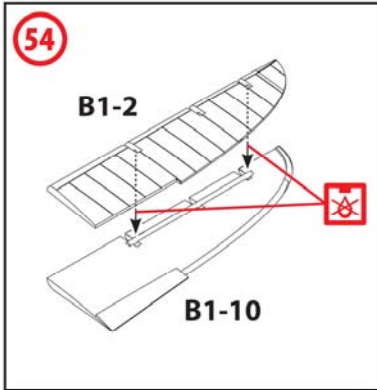
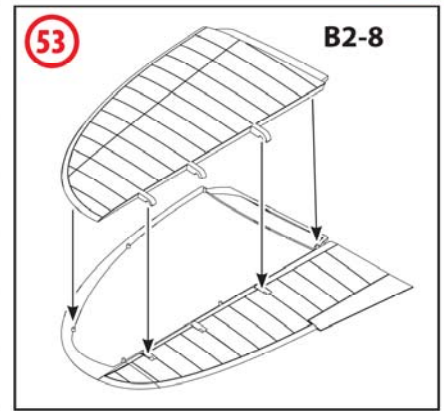
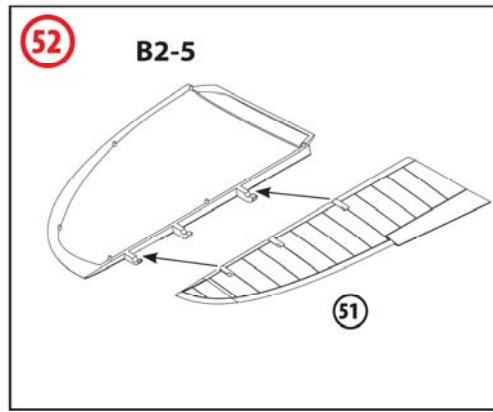
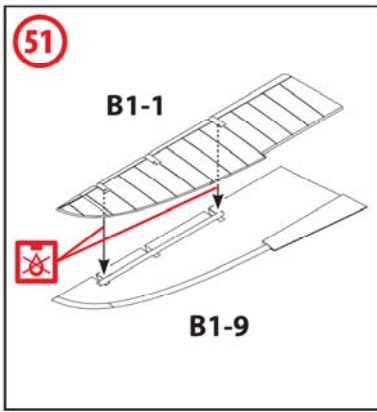

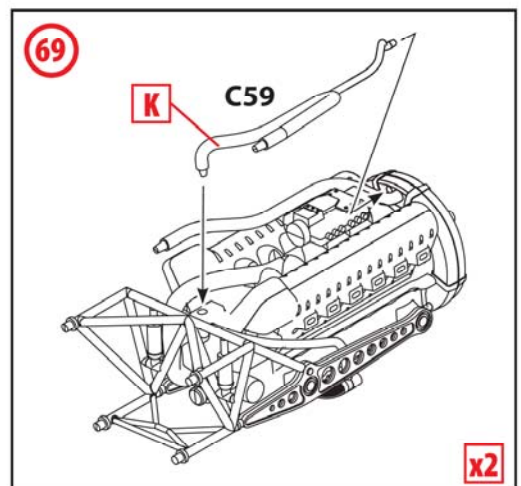
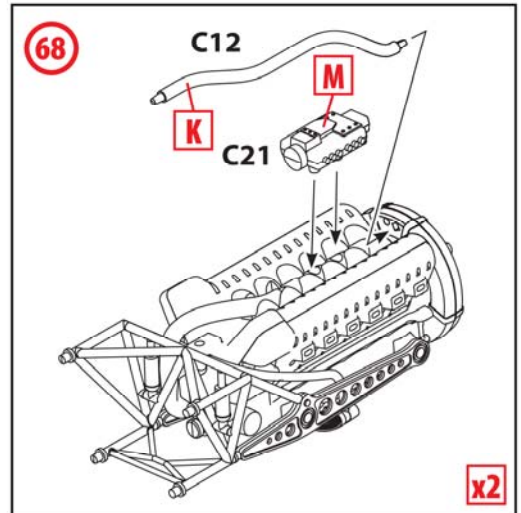
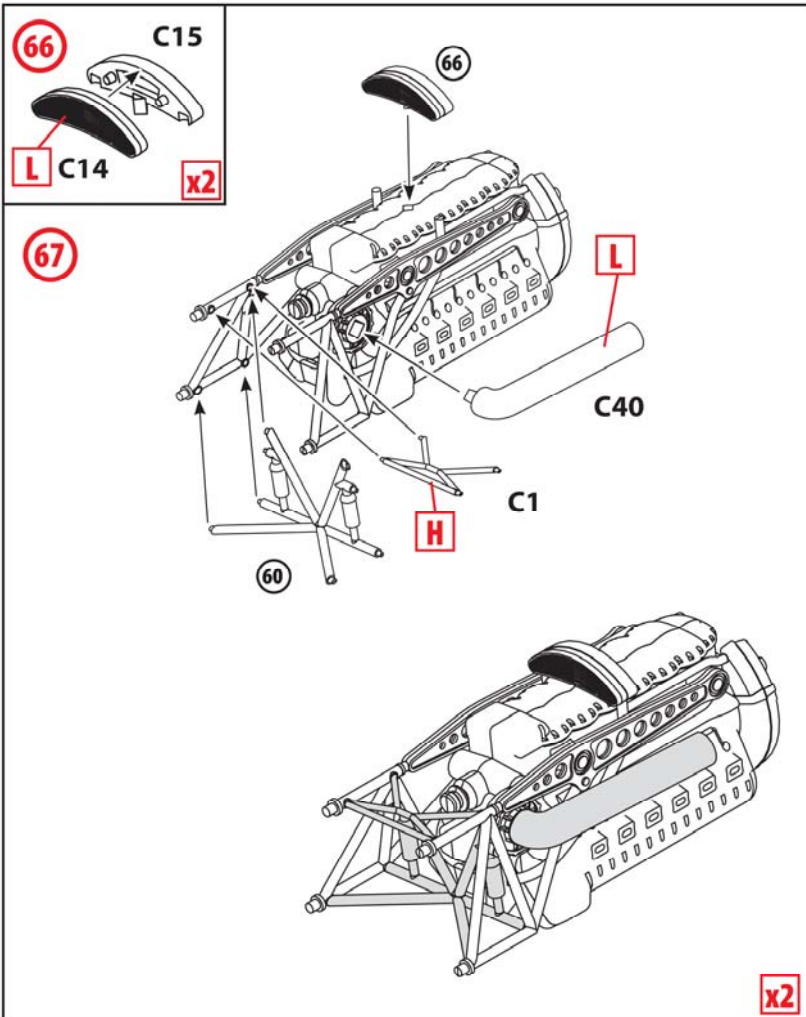
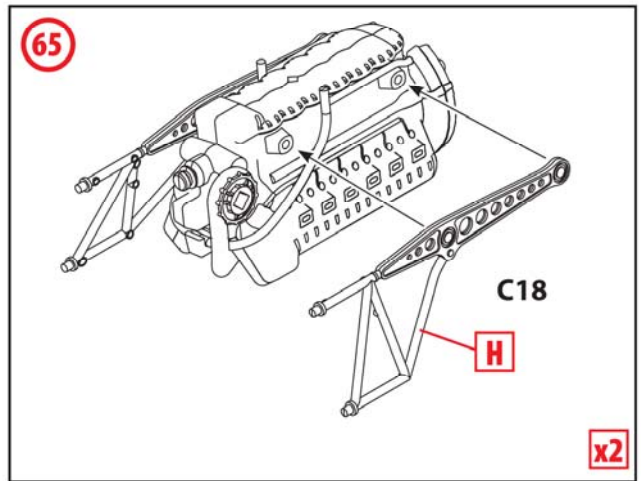
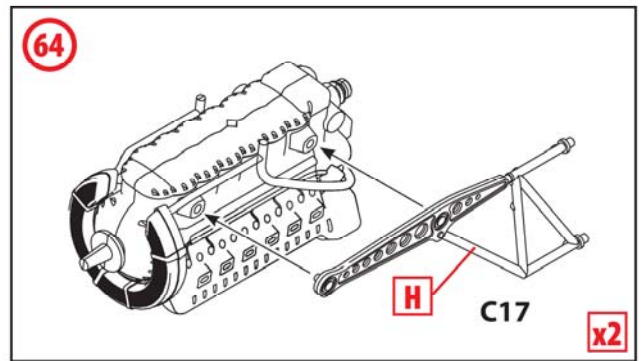
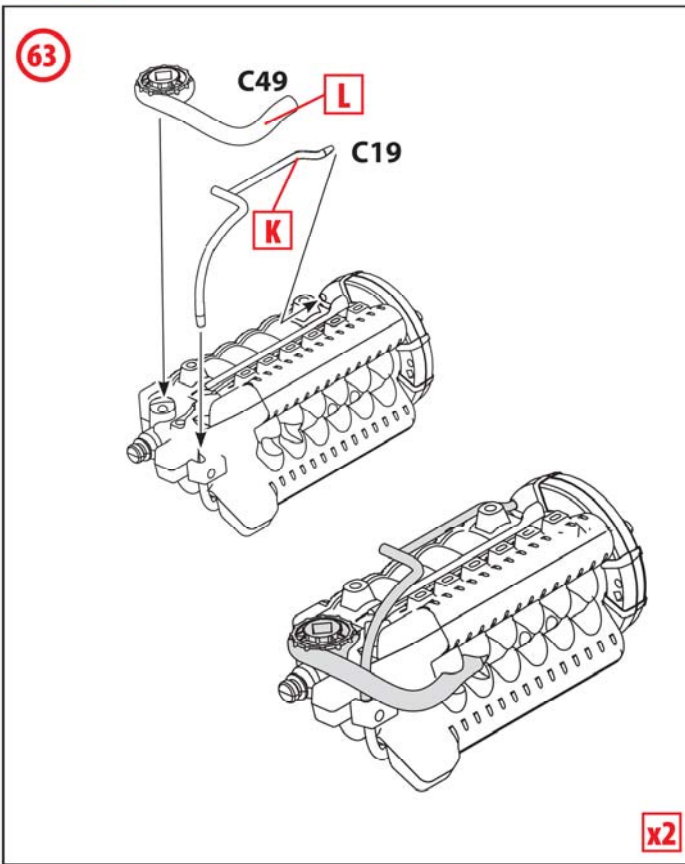

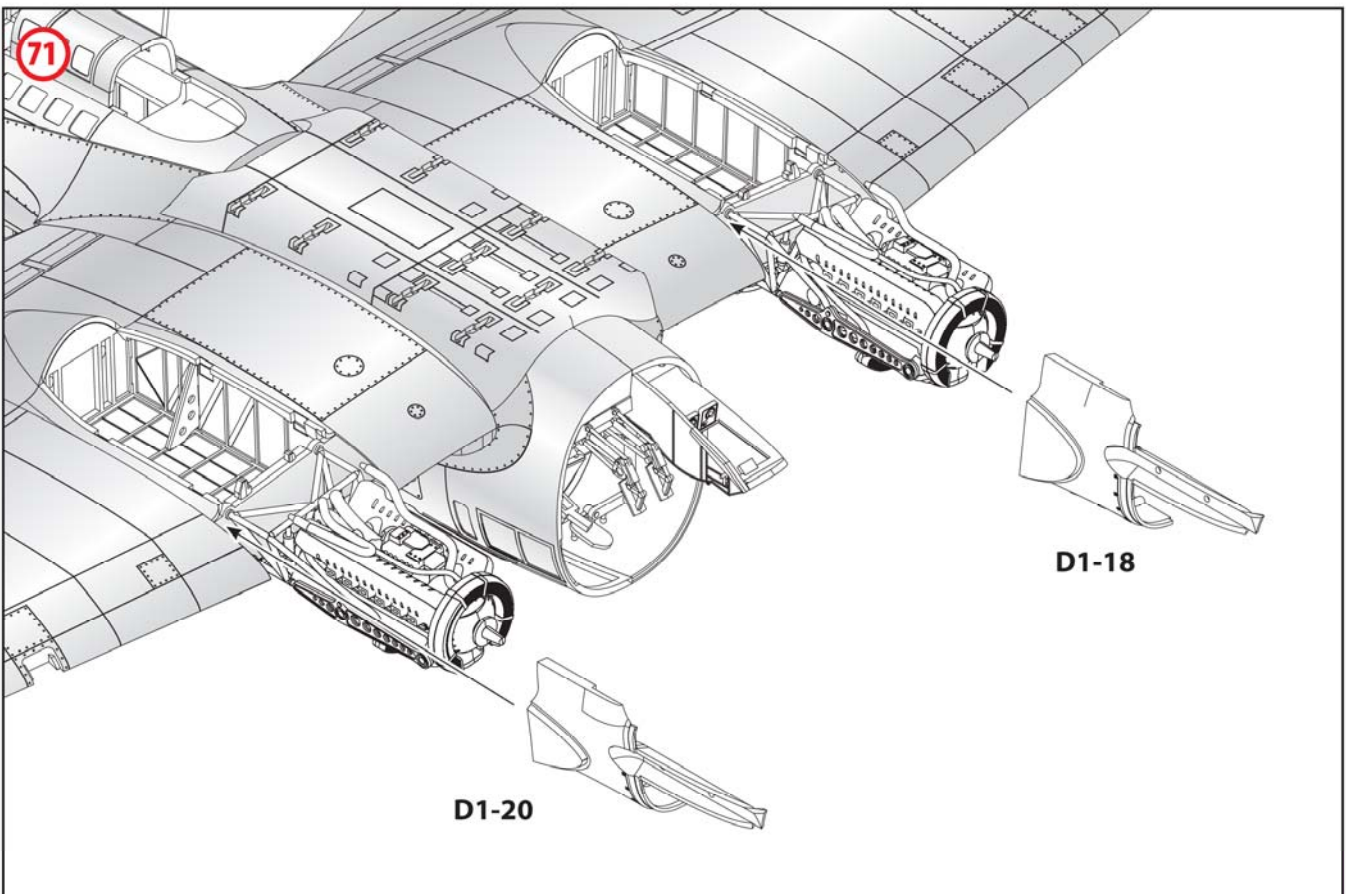
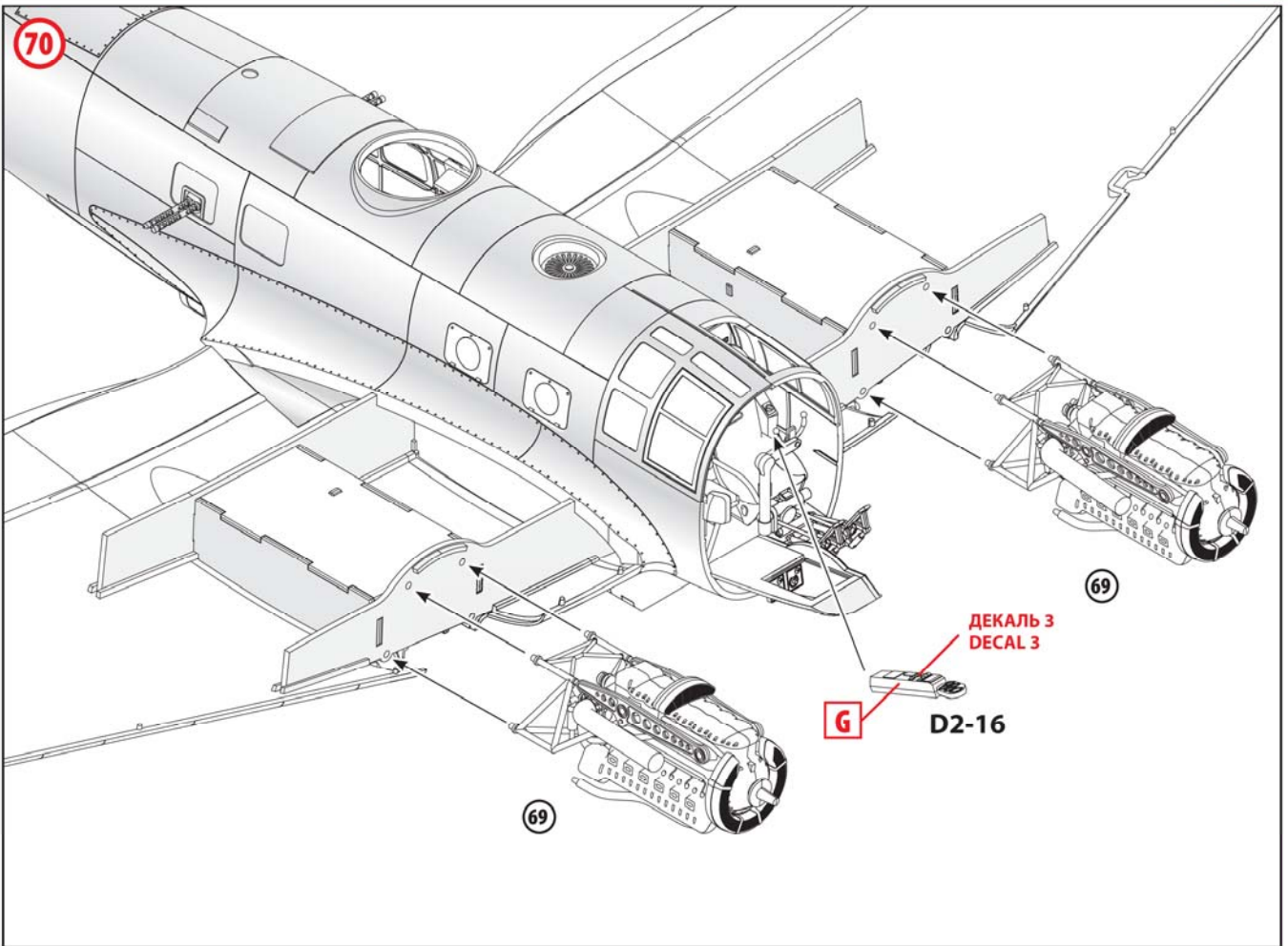

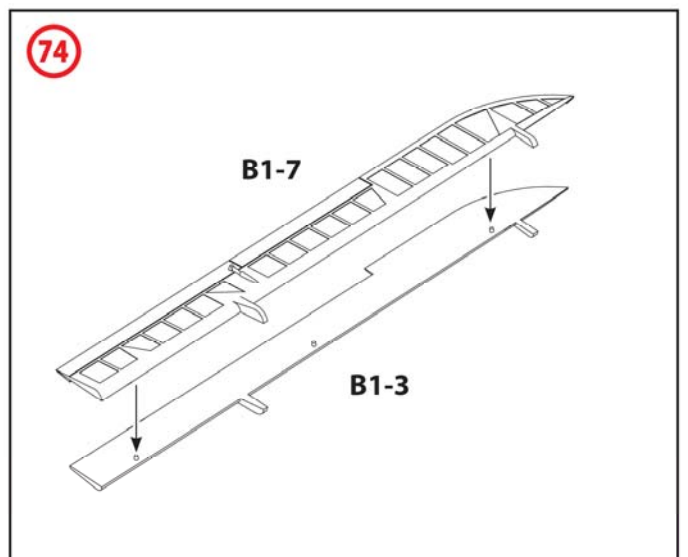
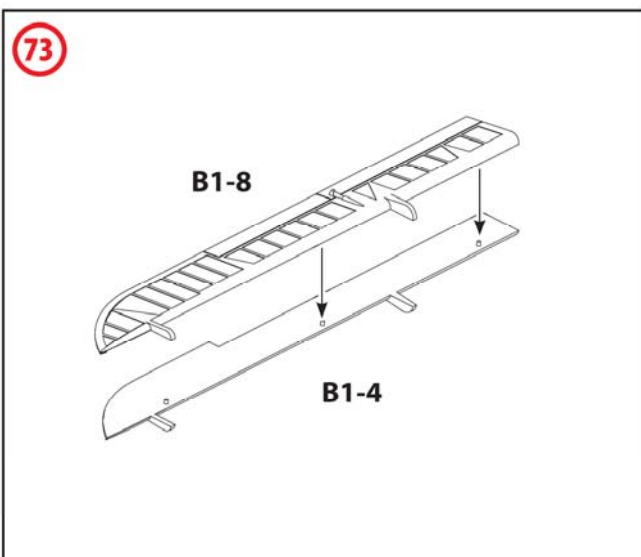
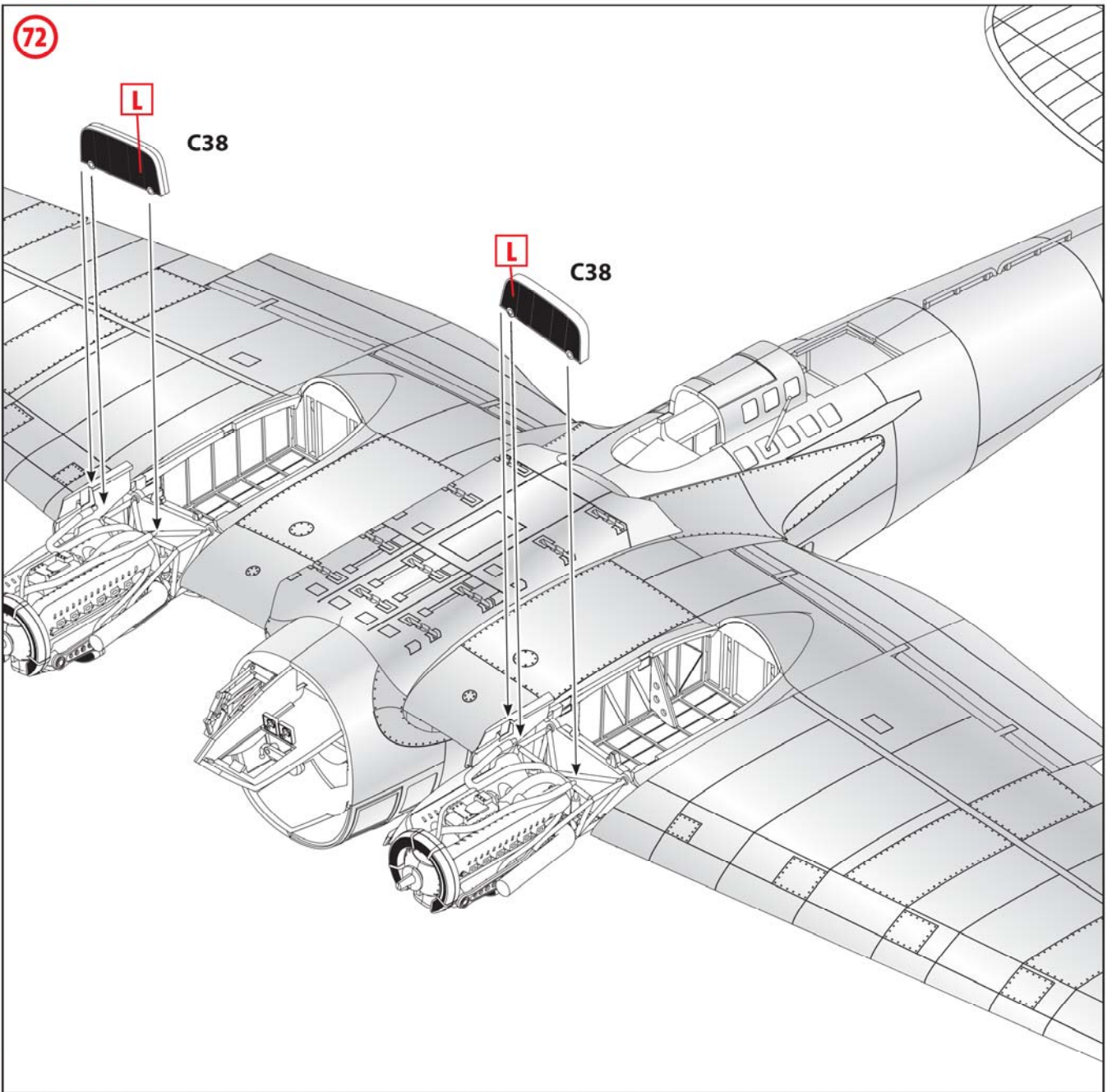

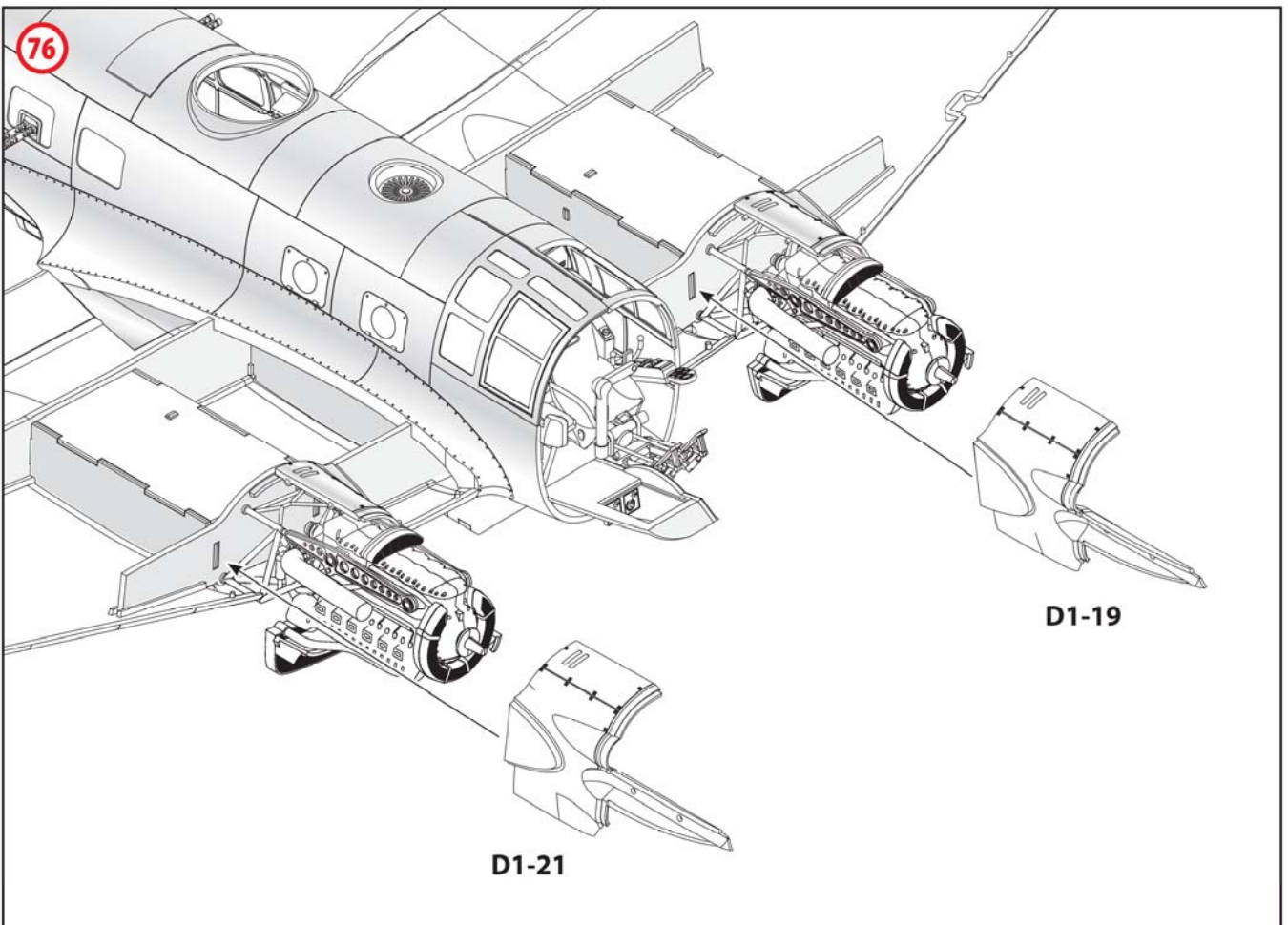
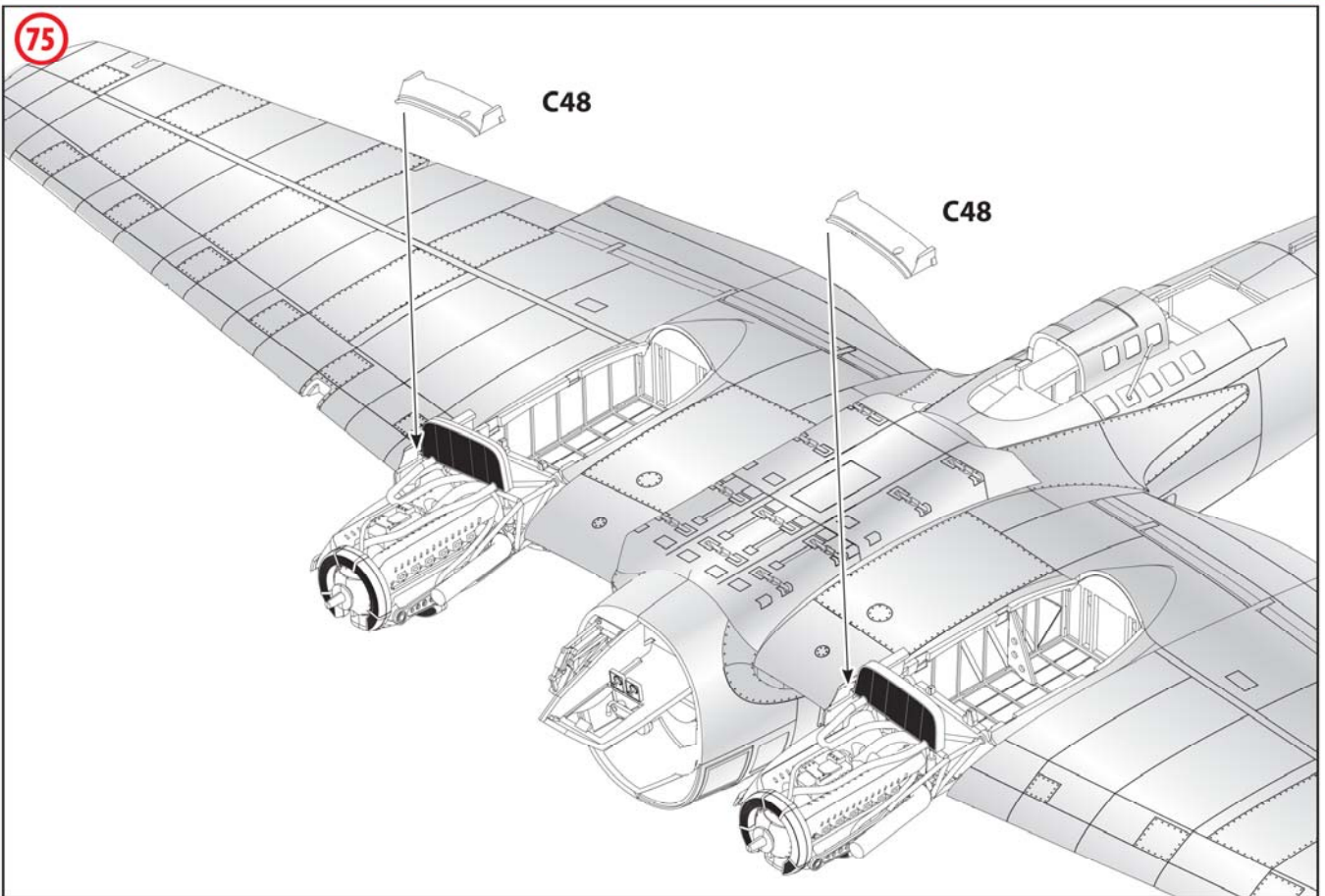

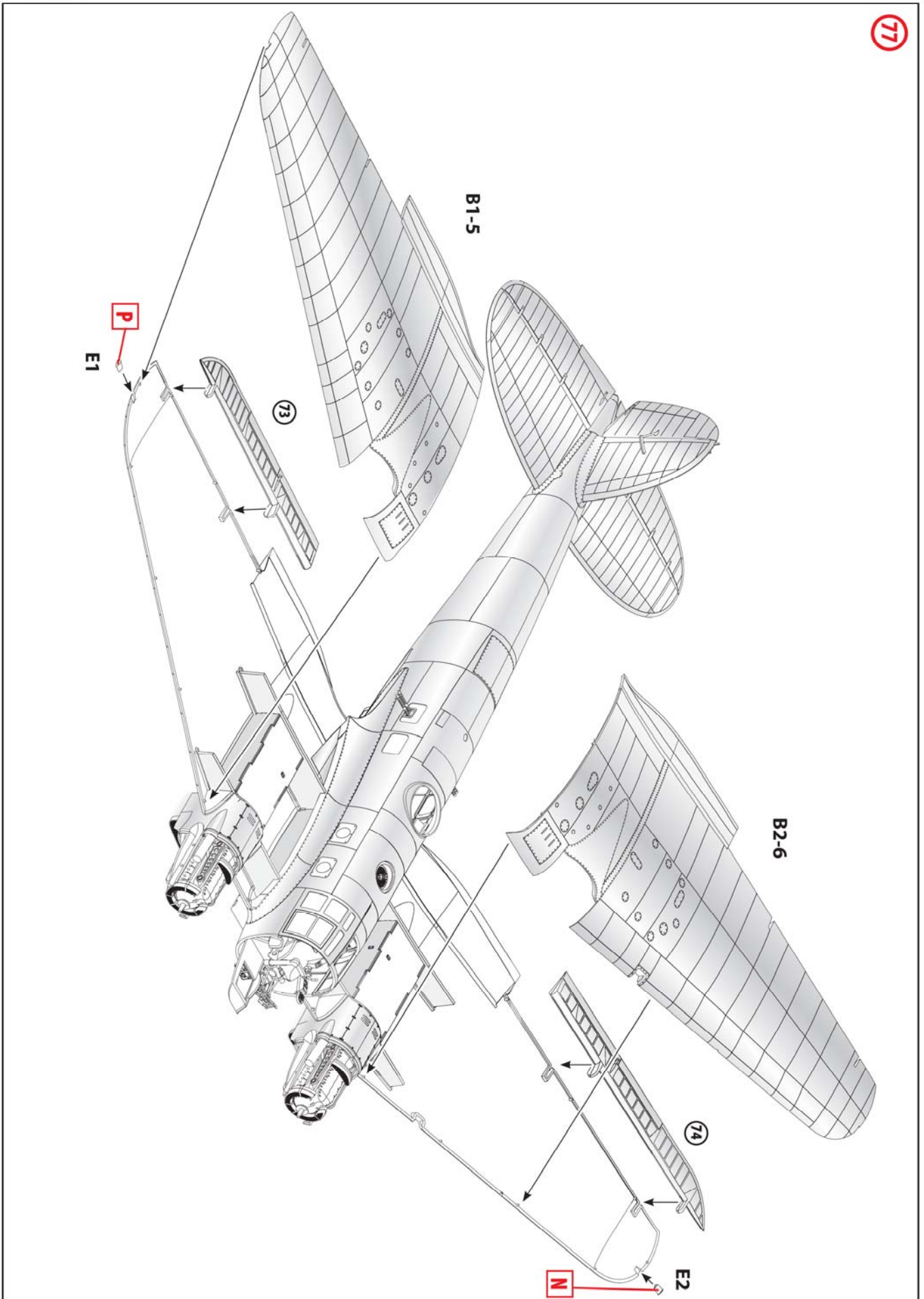

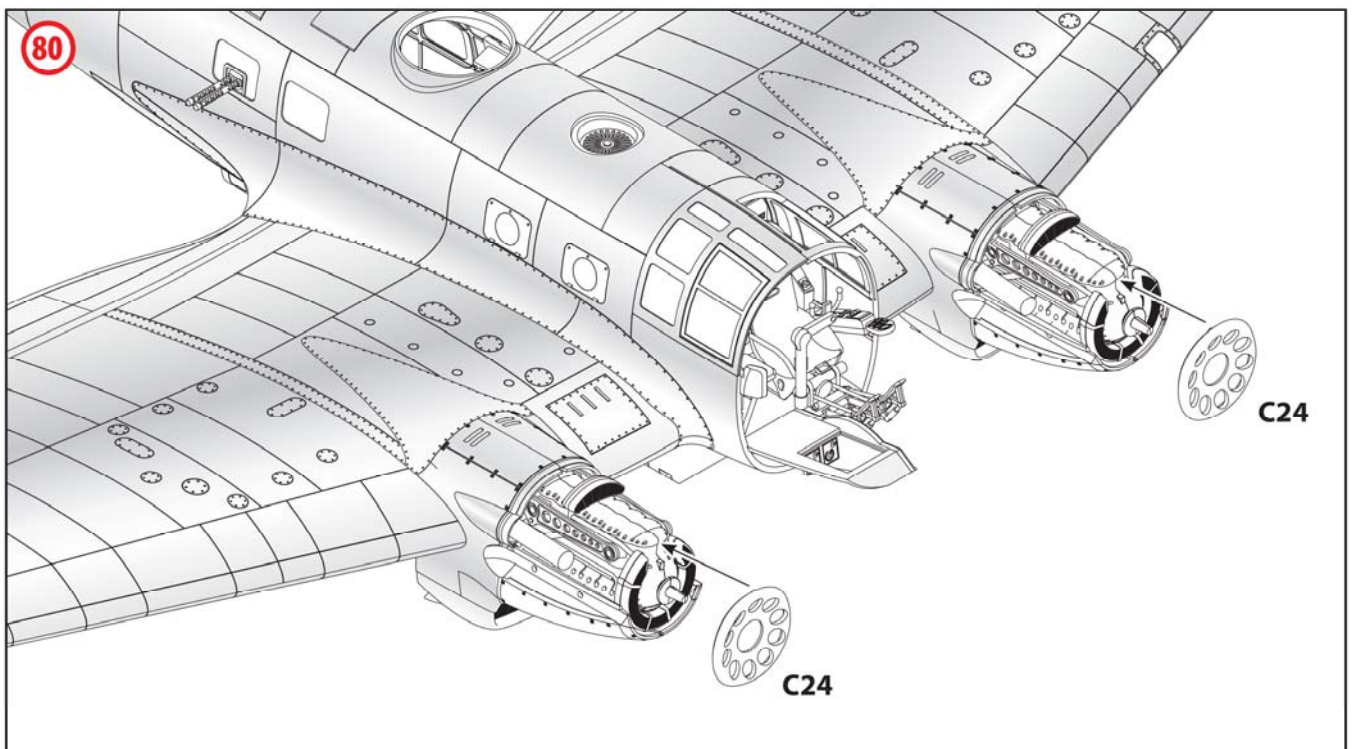
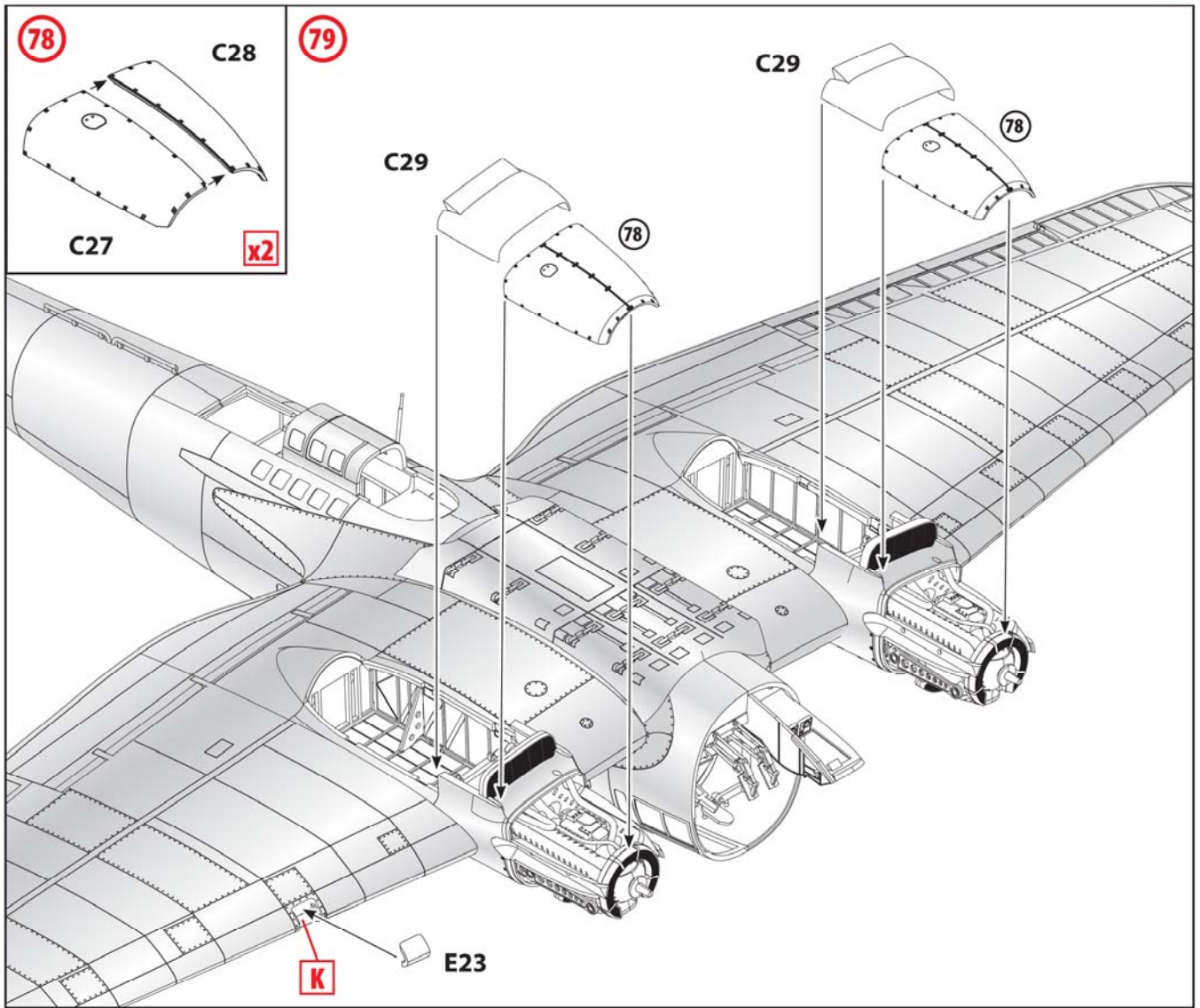

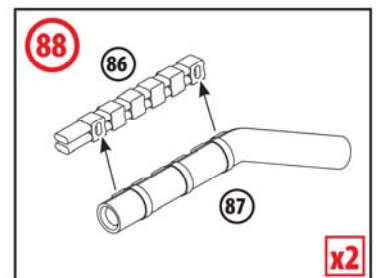
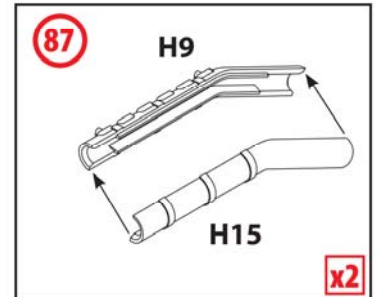
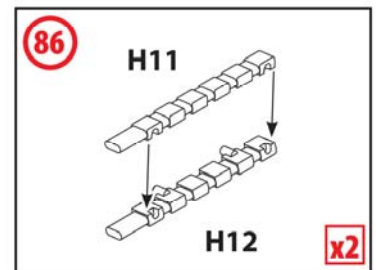
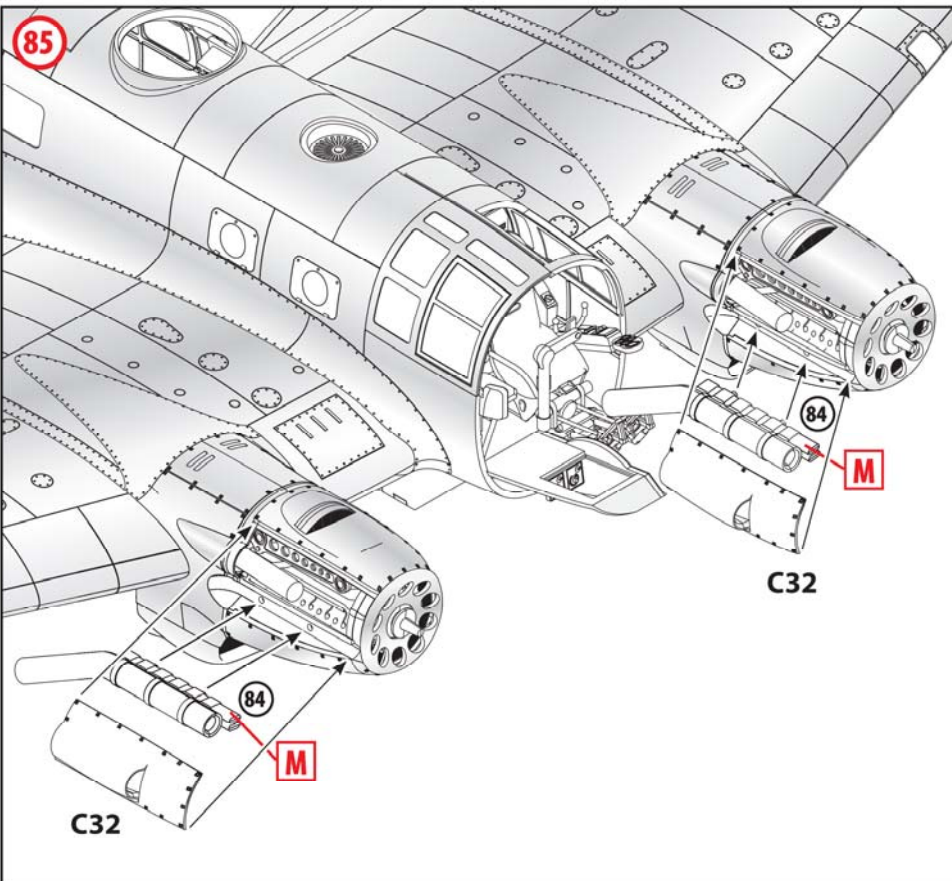
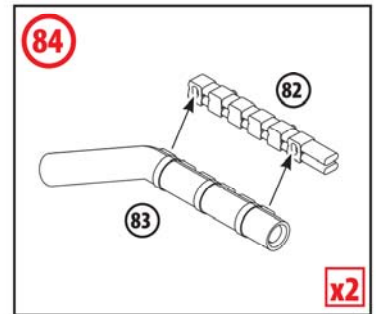
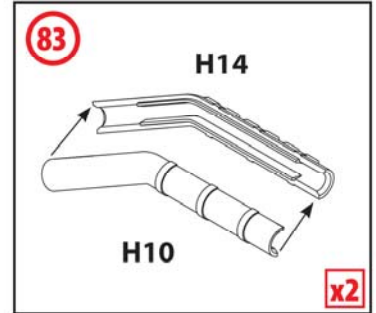
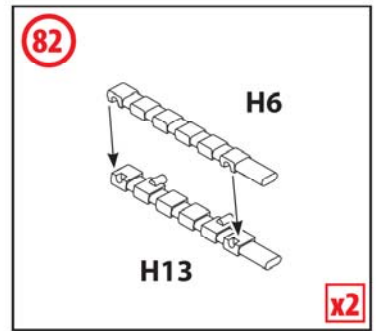
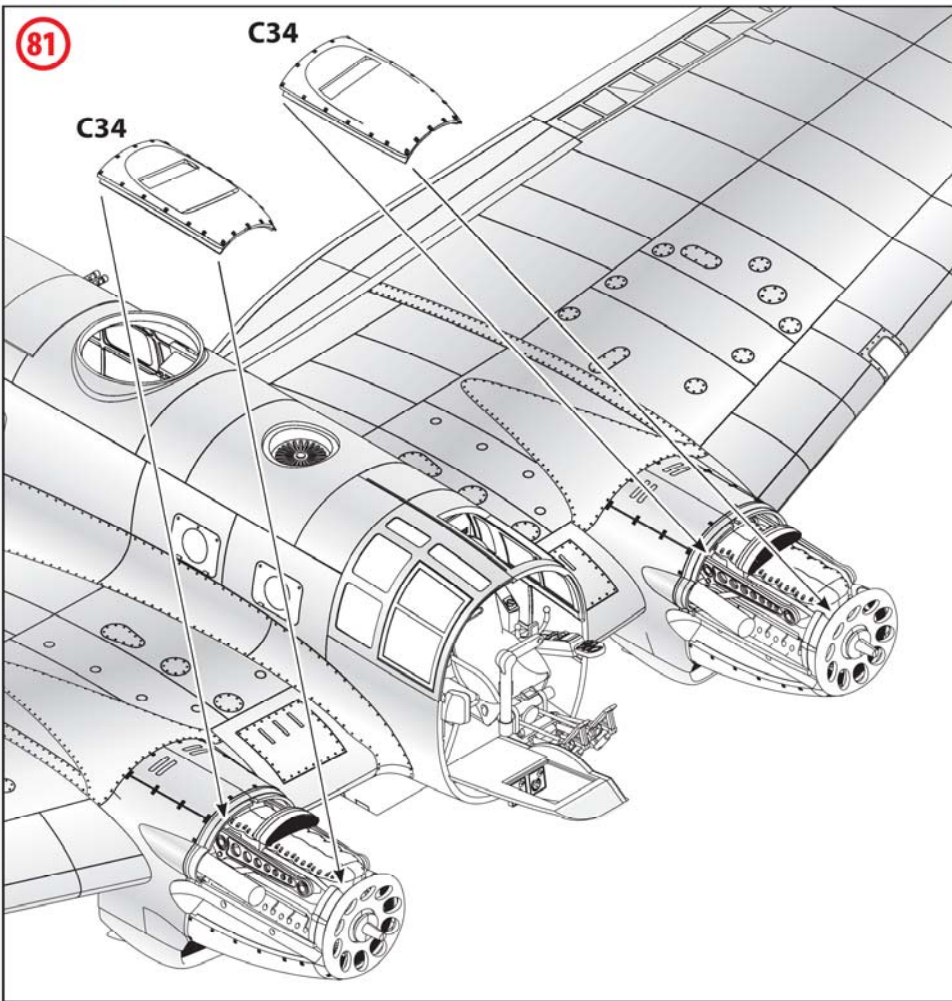

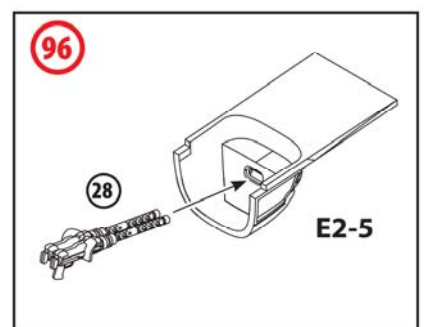
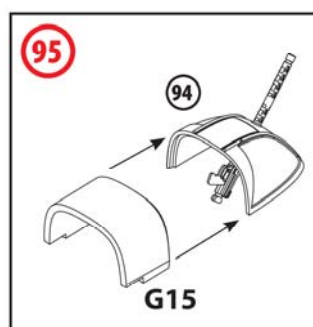
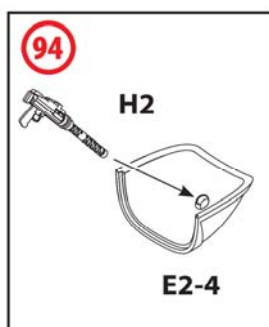
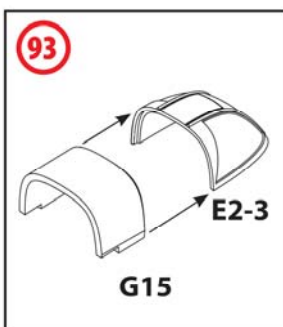
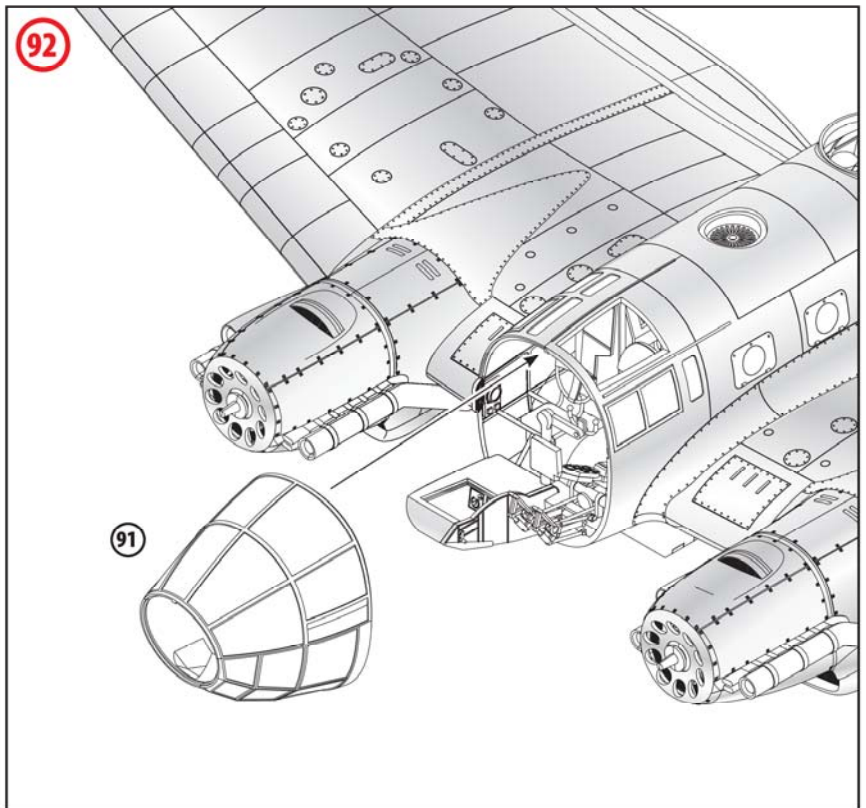
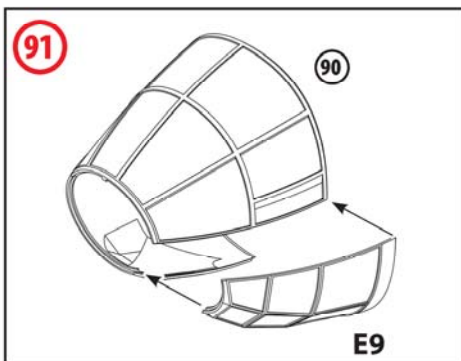
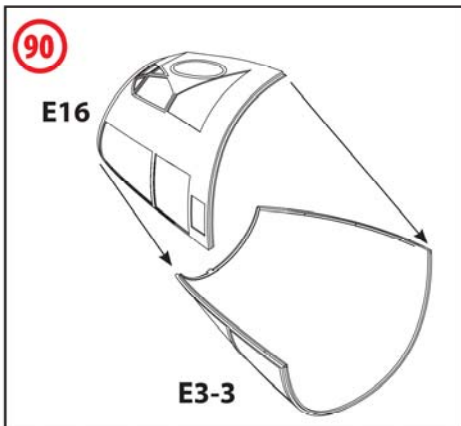
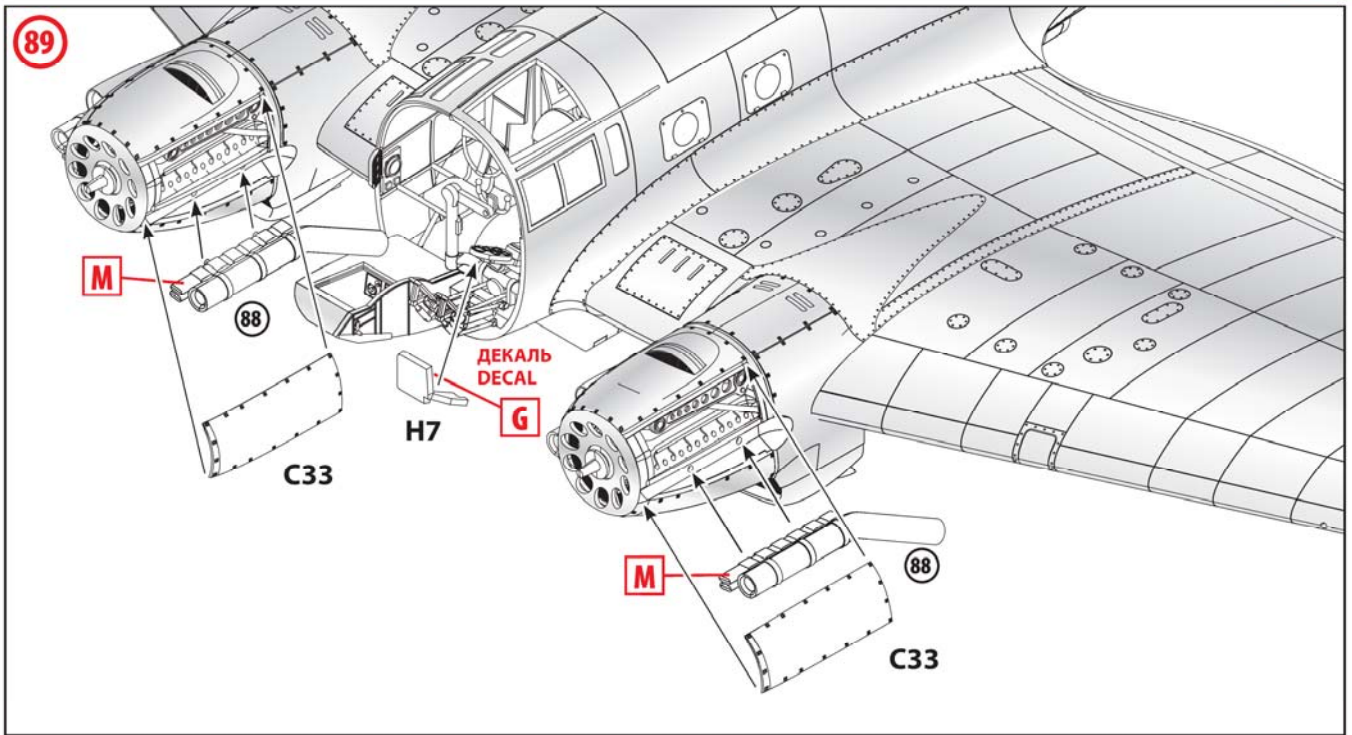

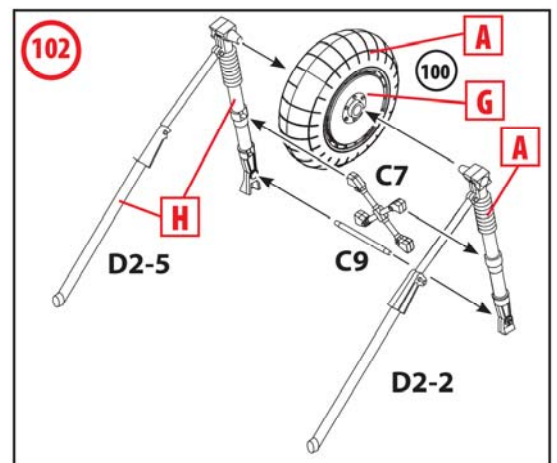
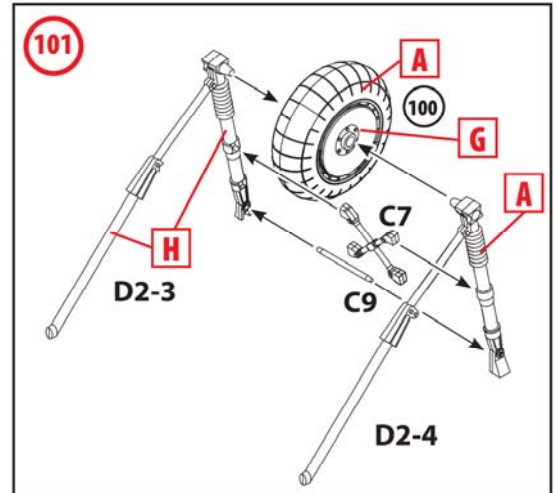
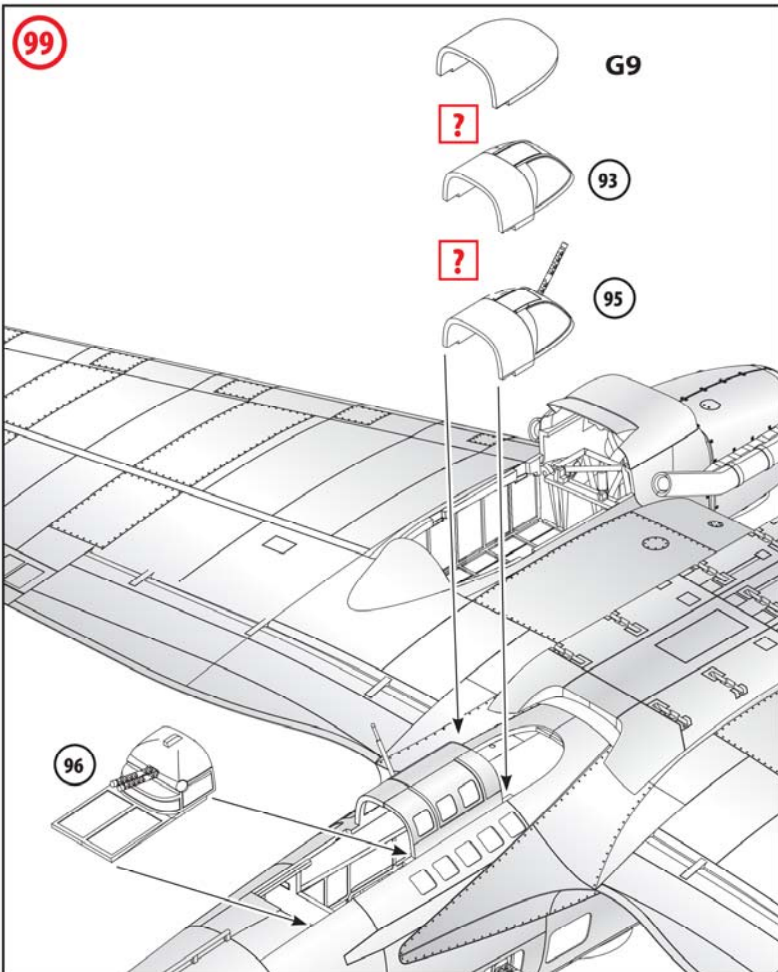
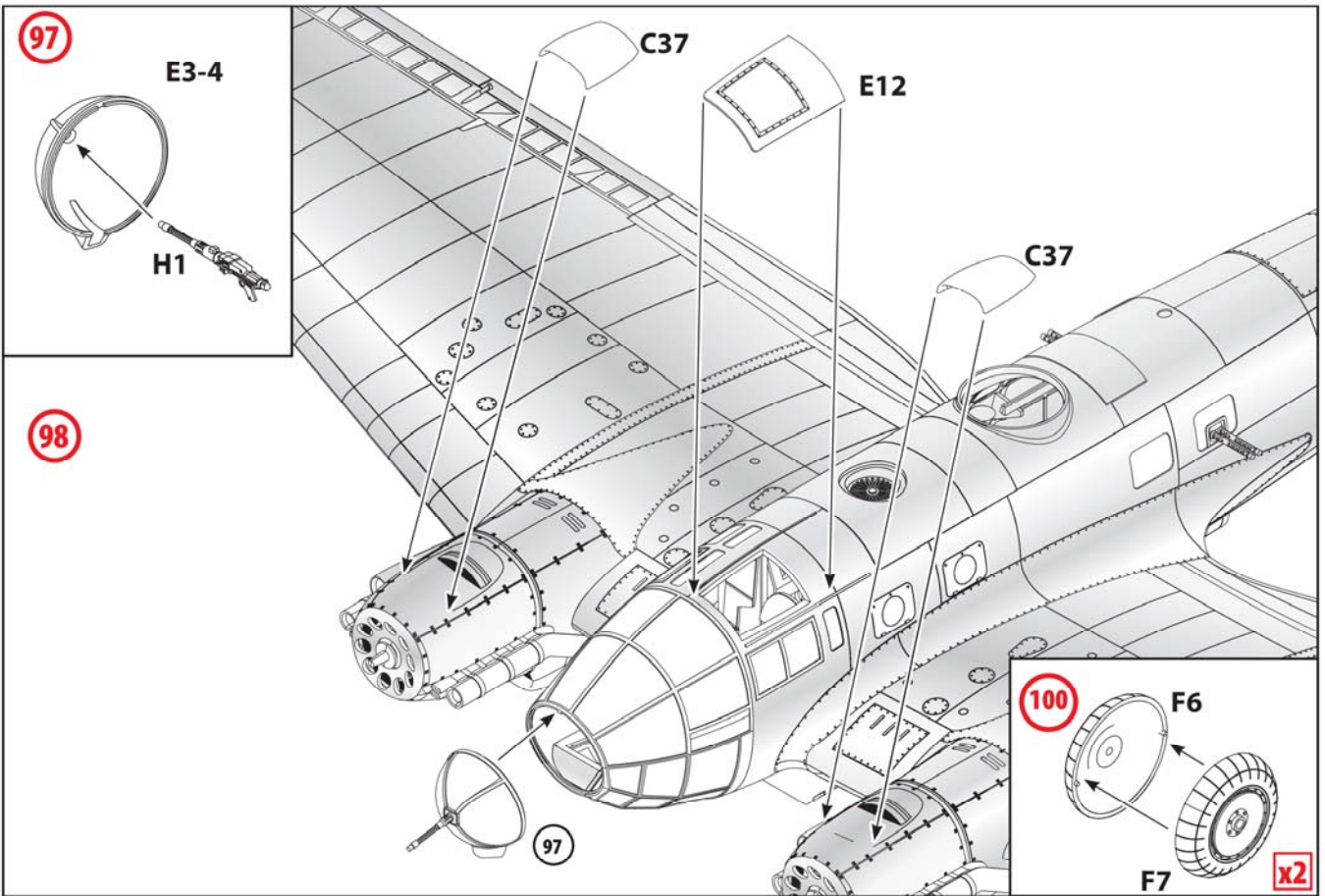

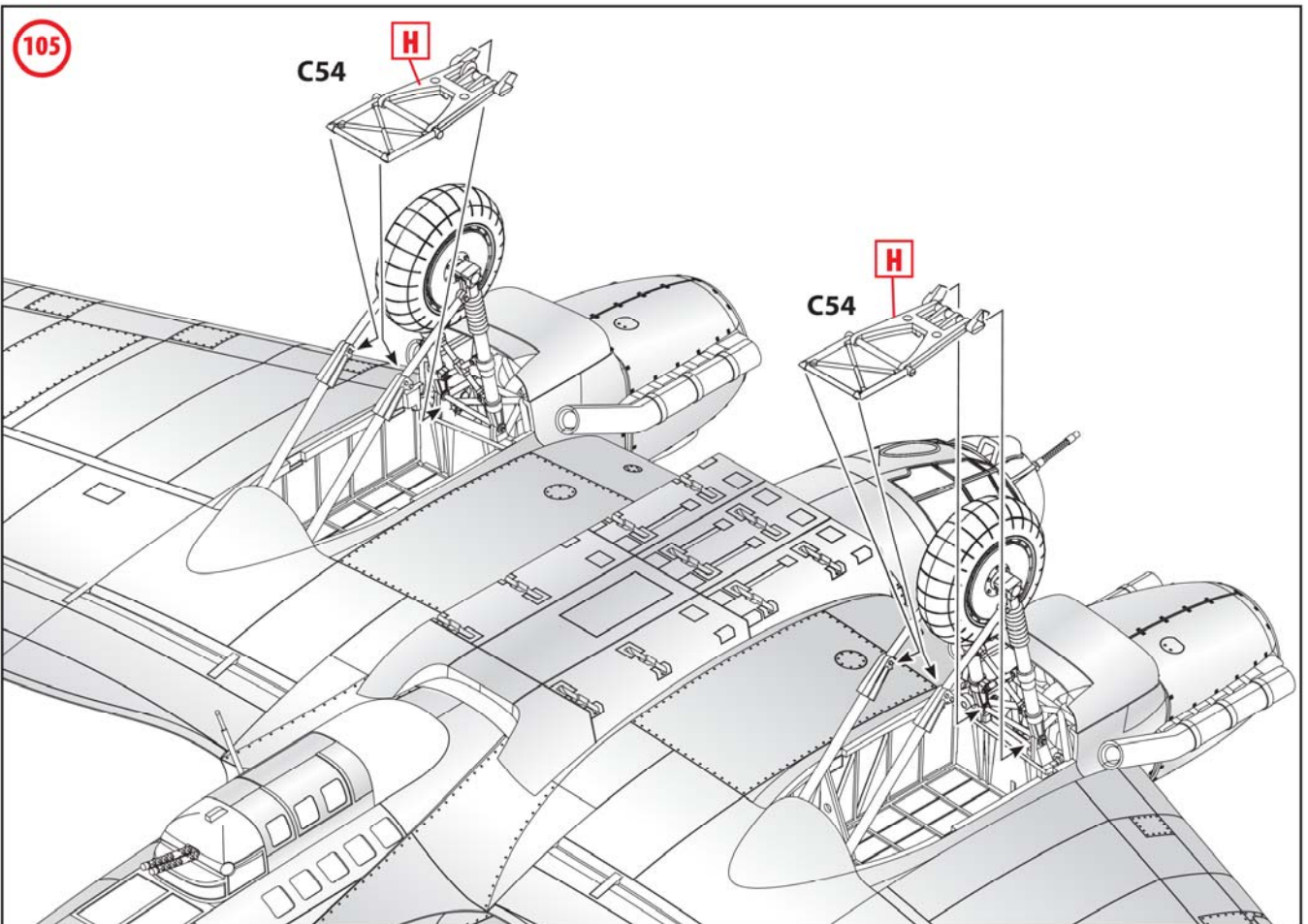
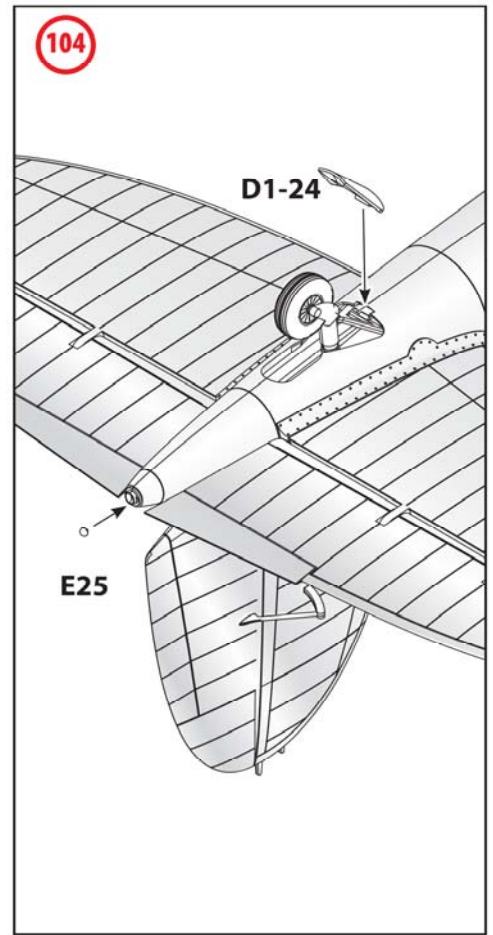
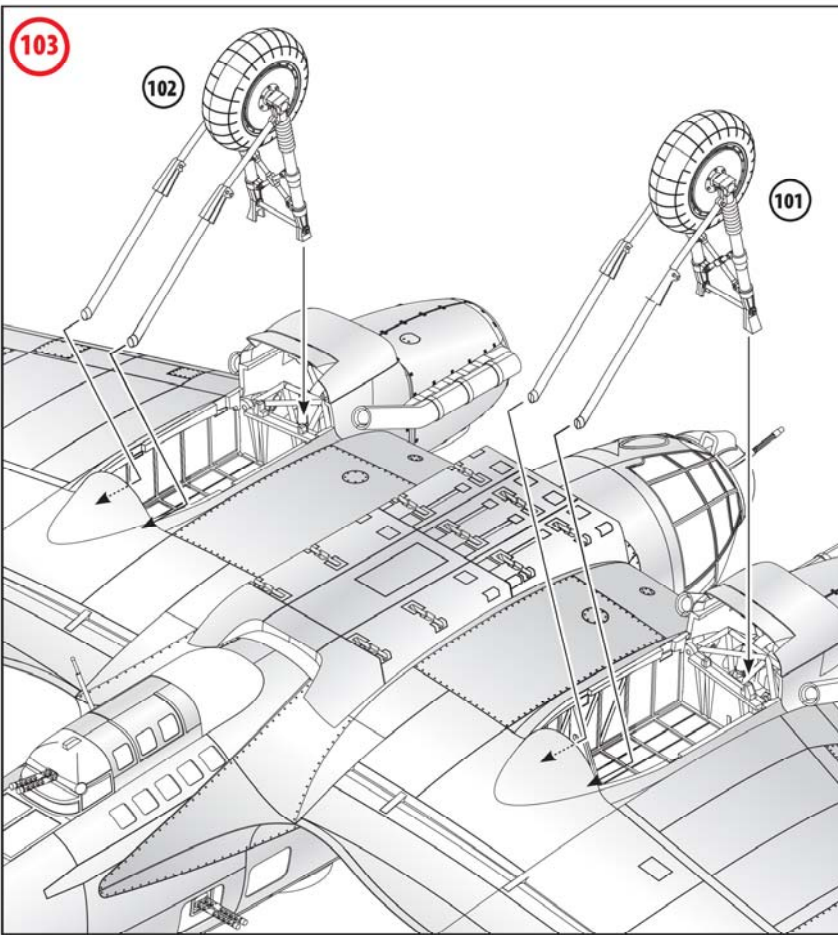

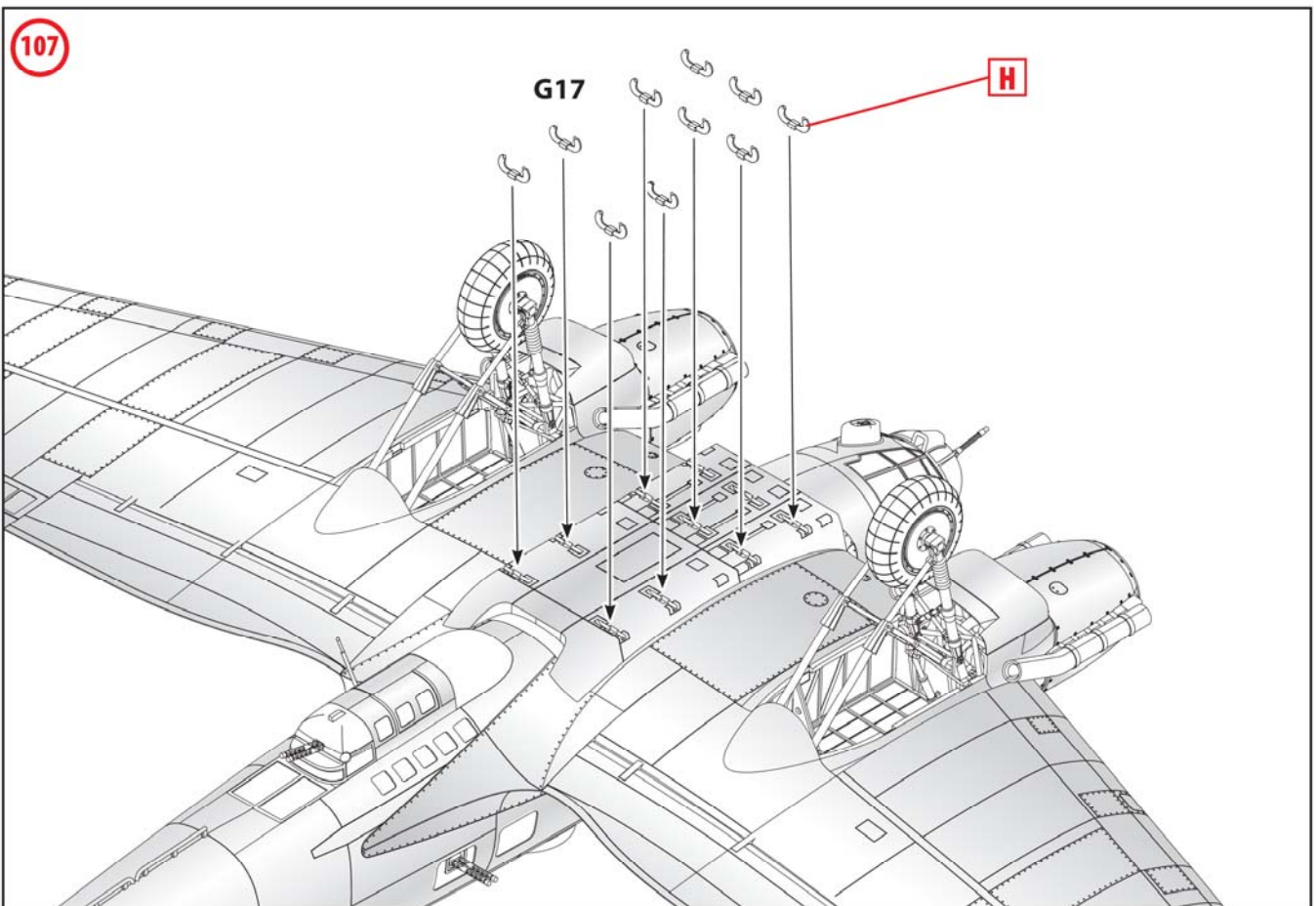
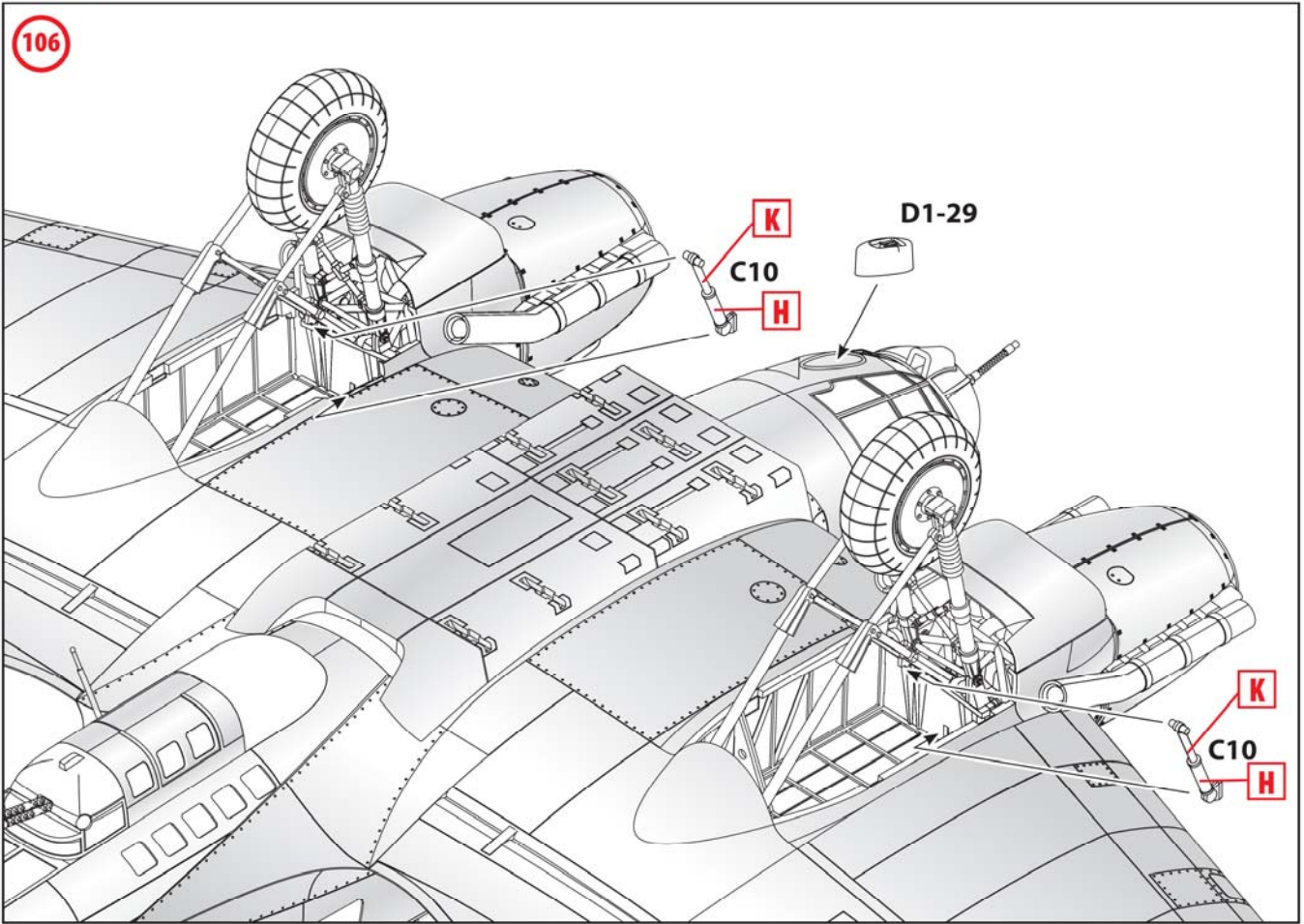

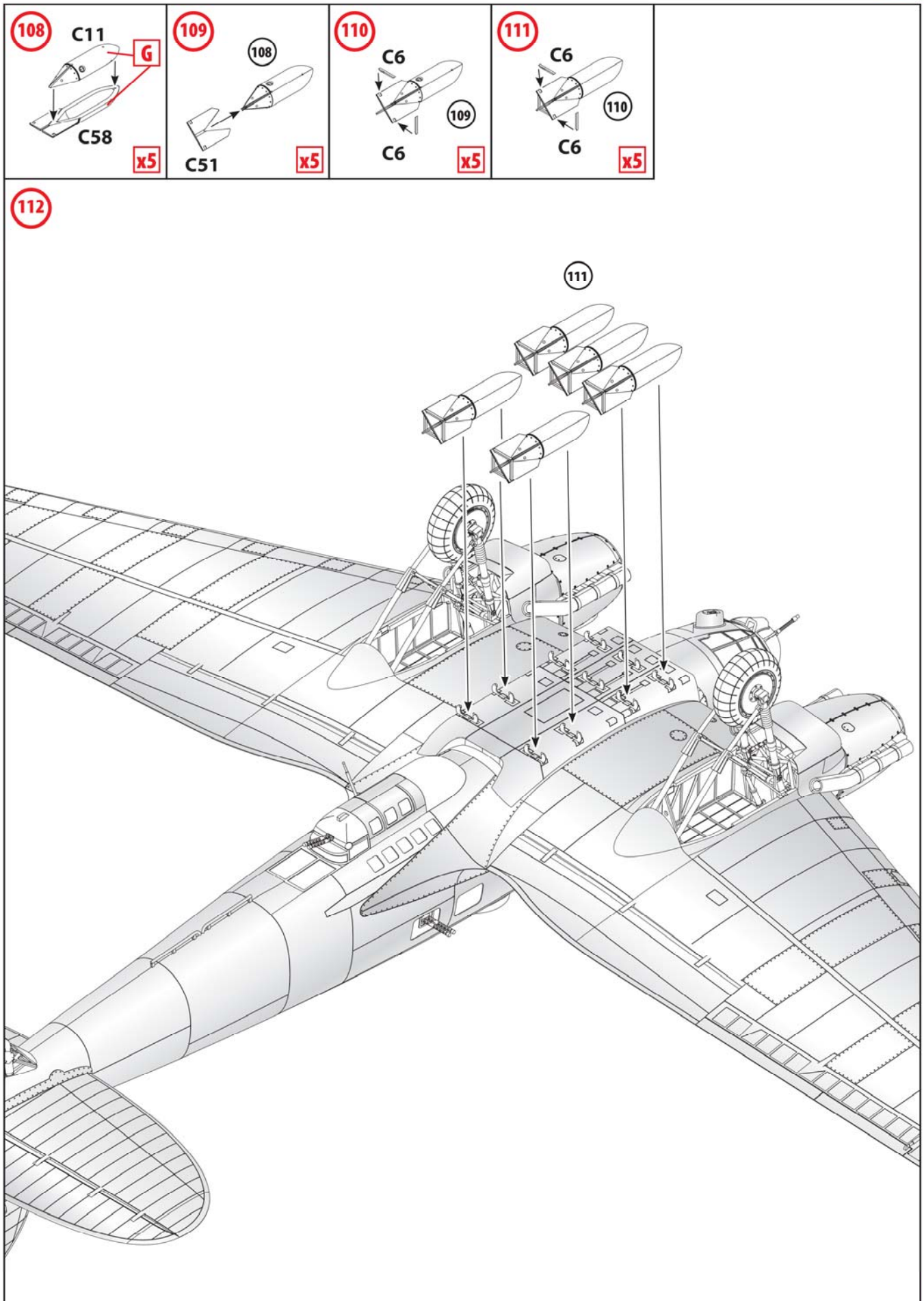

113

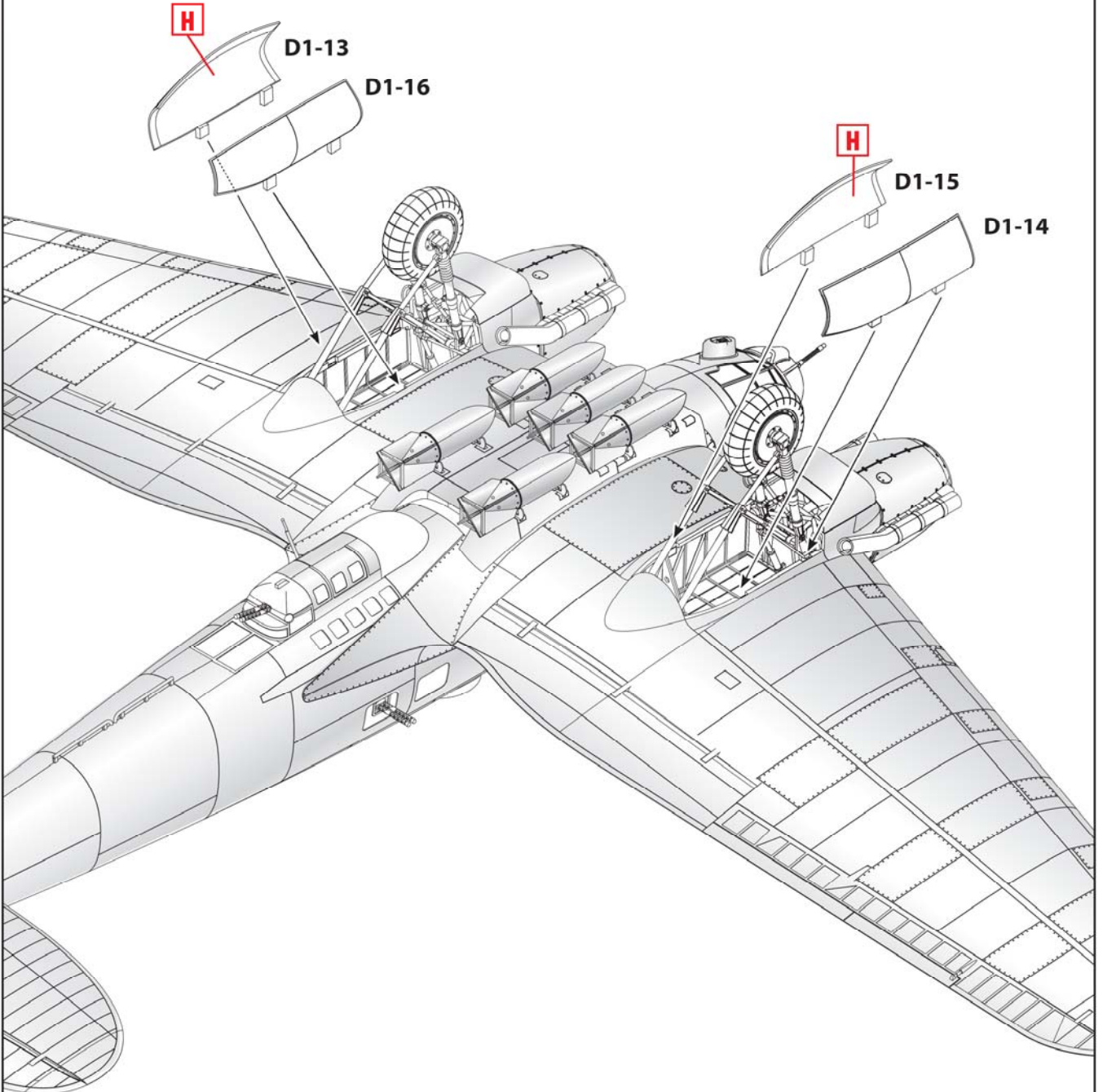

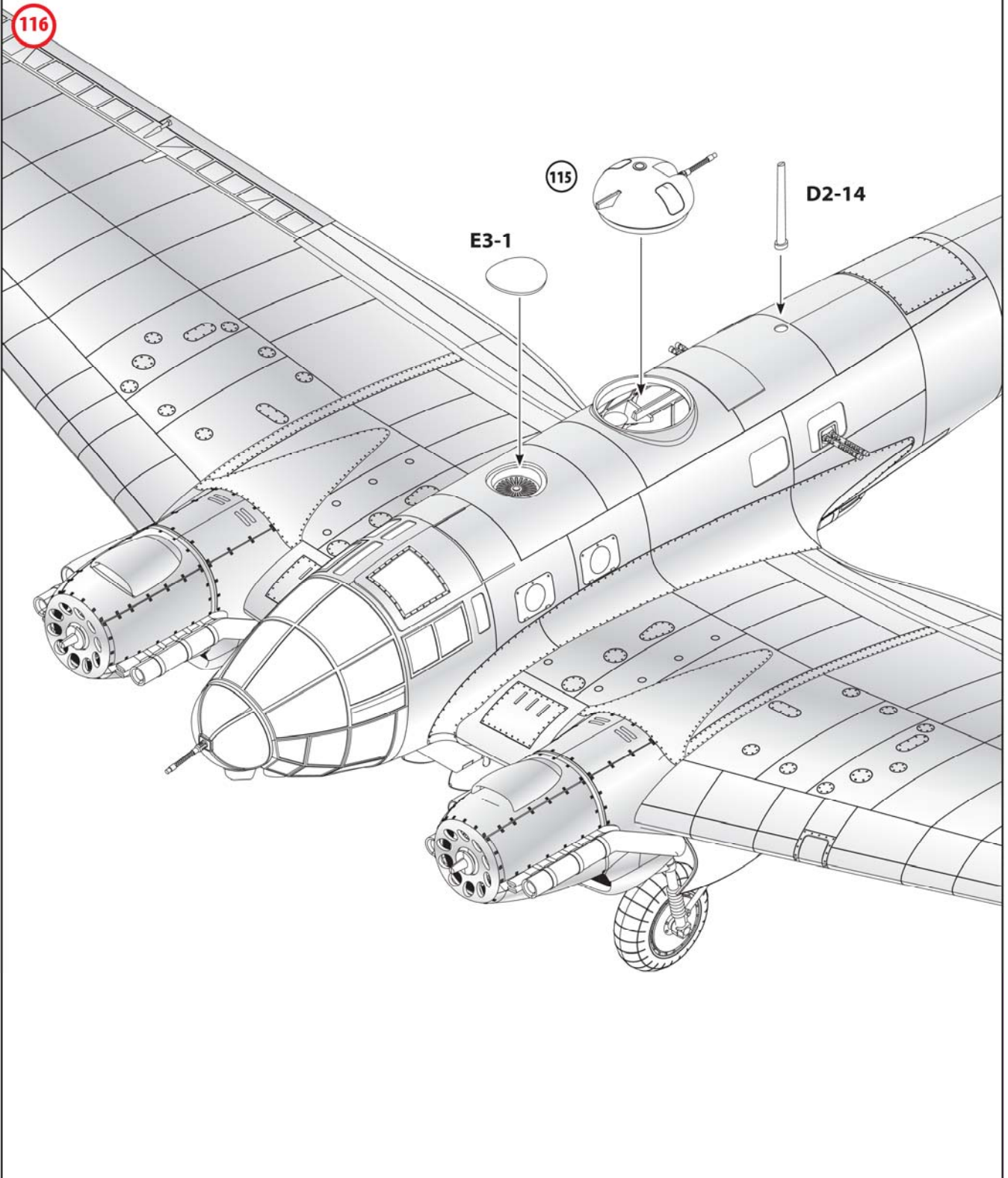
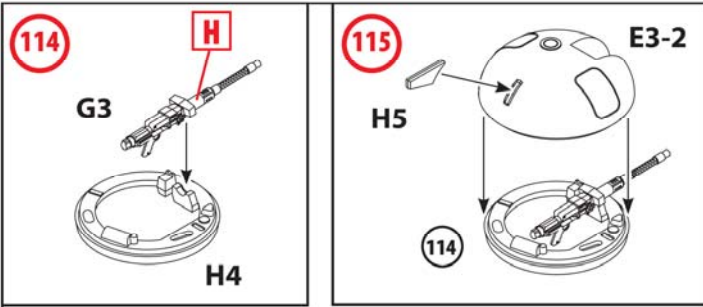

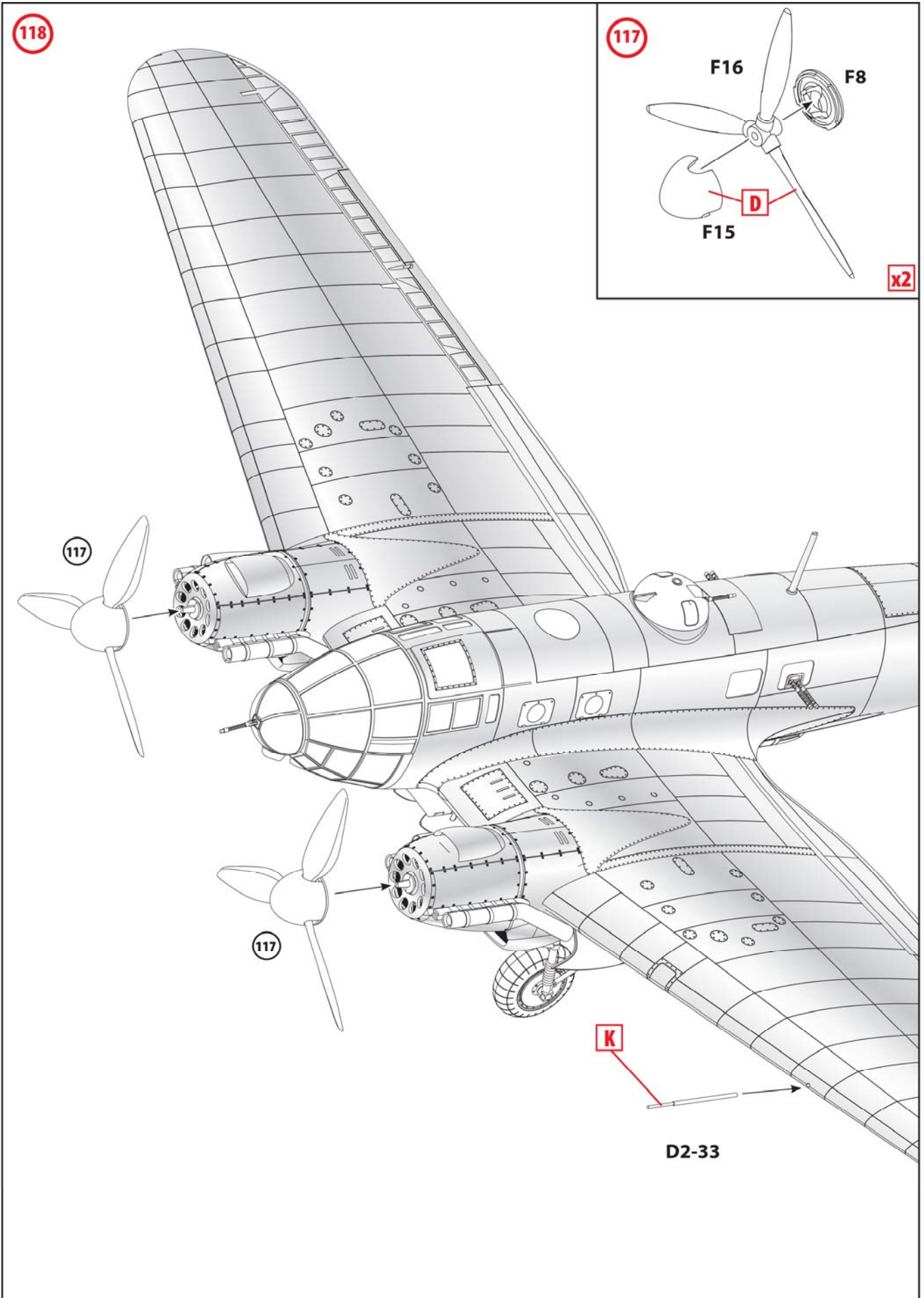

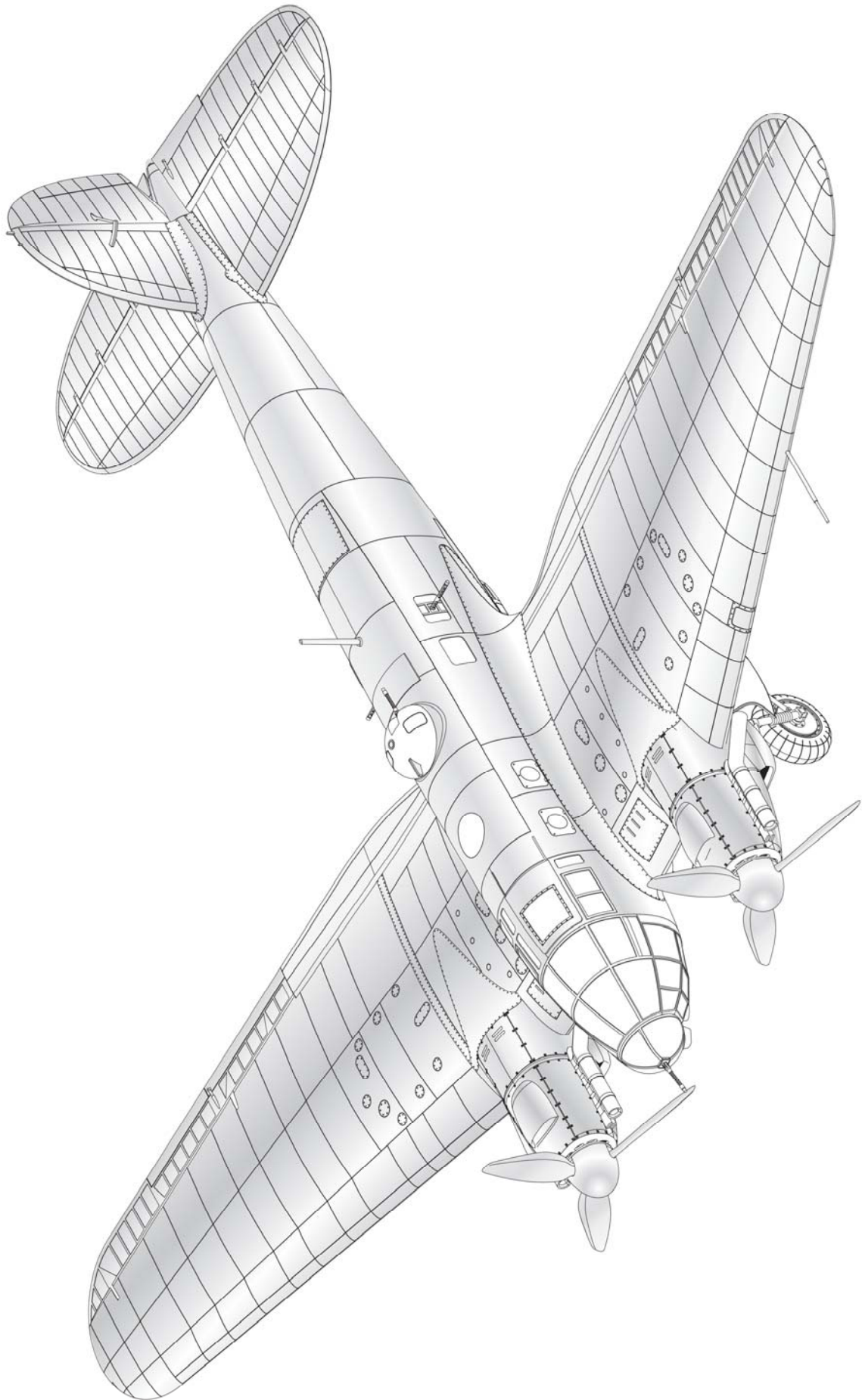

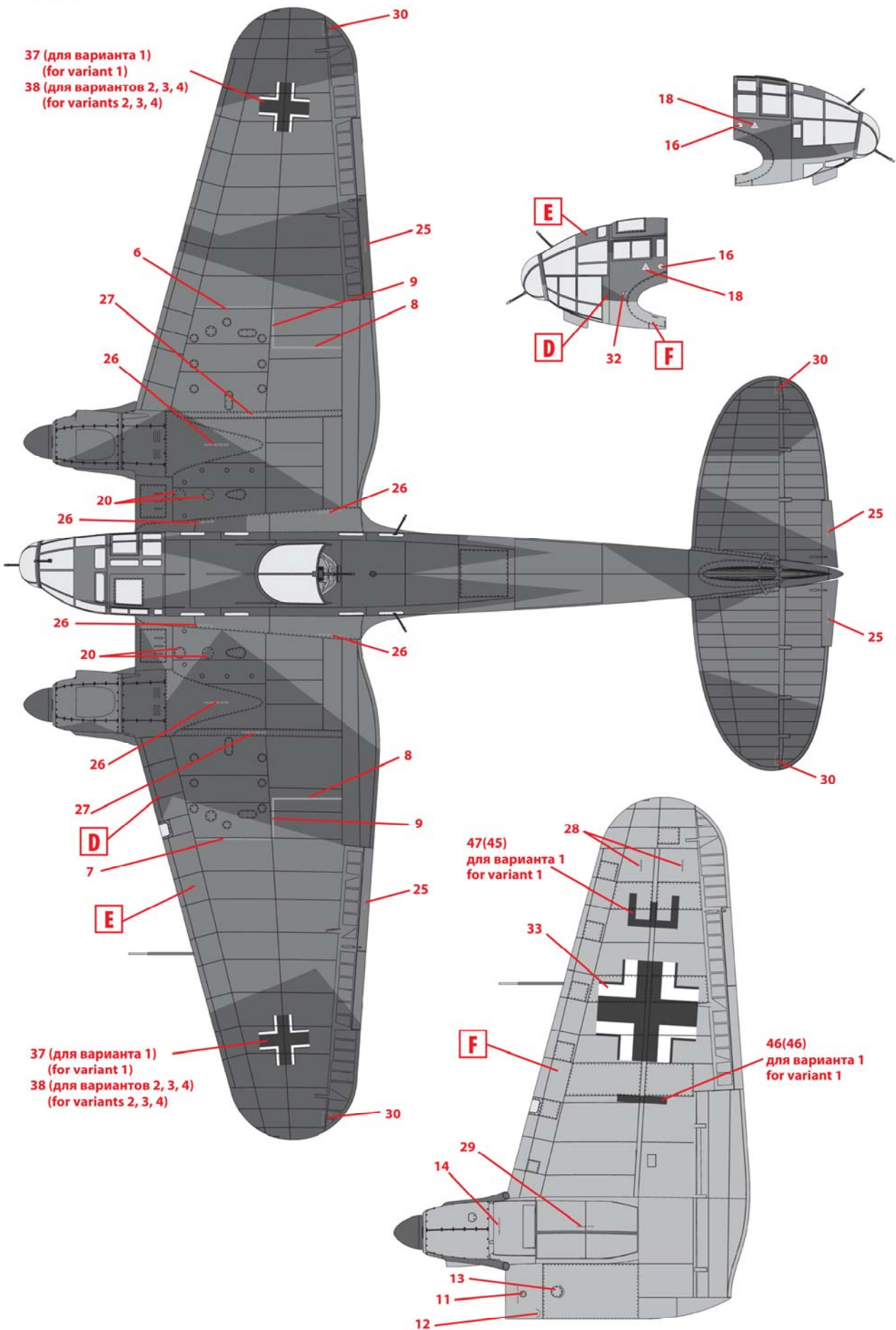

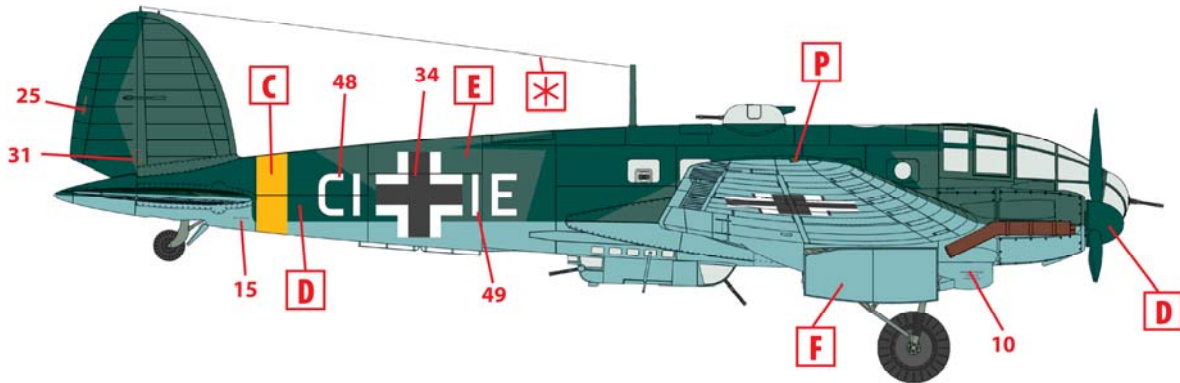
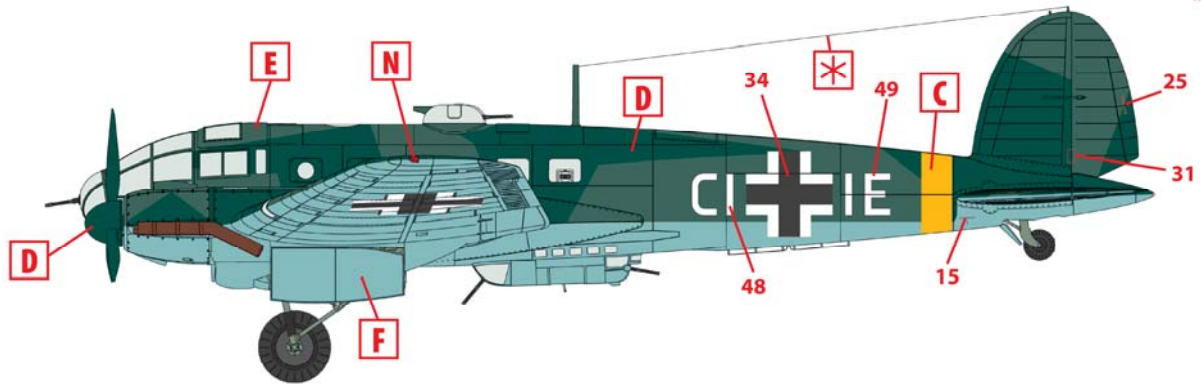

1. He 111H-16/R1, EKdo 16, 1944 г.
He 111H-16/R1, EKdo (Erprobungs-Kommando) 16, 1944

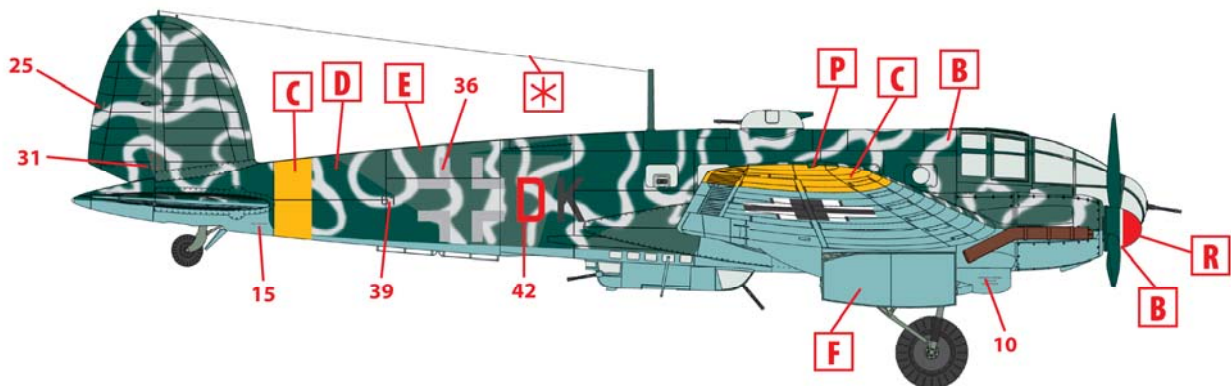
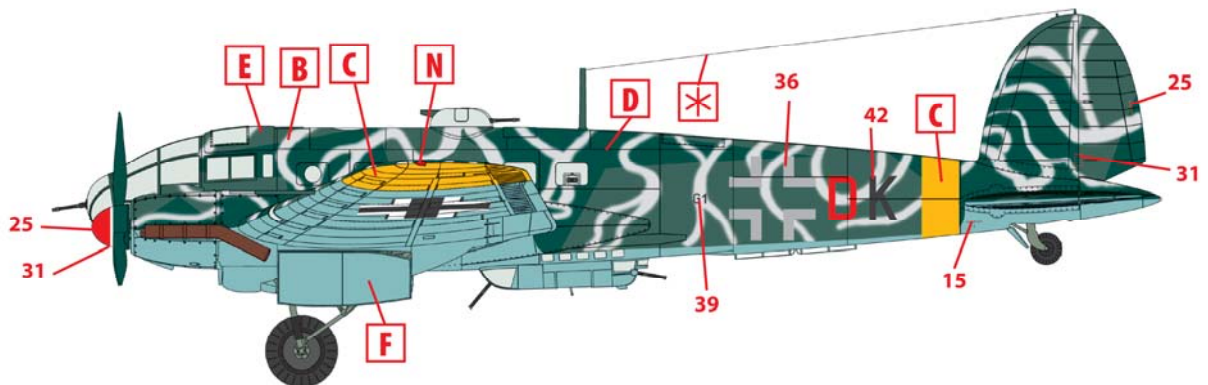

2. He 111H-16/R1, 2./KG 55, аэродром Сарабуз, Крым, декабрь 1943 г.
He 111H-16/R1, 2./KG 55, Sarabuz airfield, Crimea, December 1943

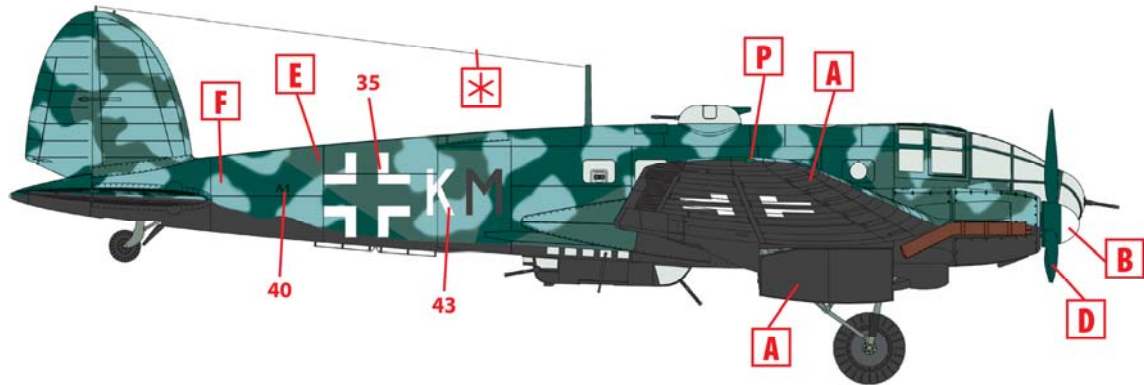
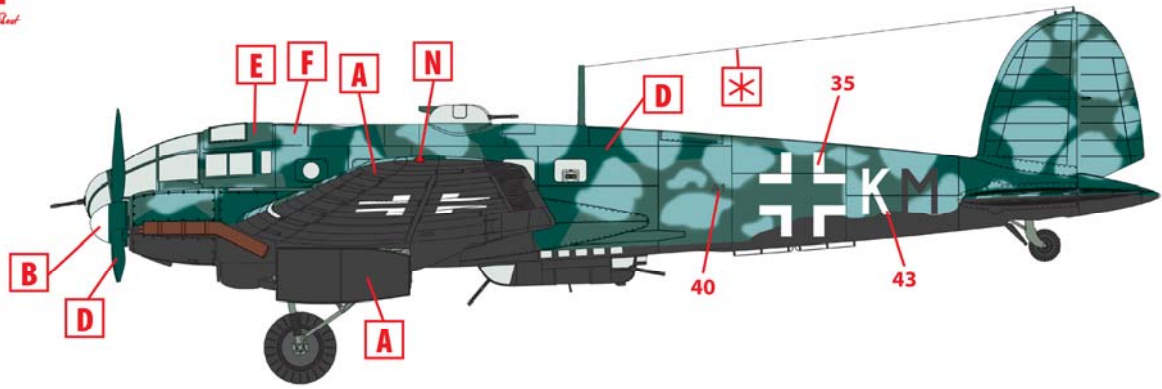

3. He 111H-20, 4./KG 53, Польша, 22 июня 1944 г.
 He 111H-20, 4./KG 53, Poland, June 22, 1944

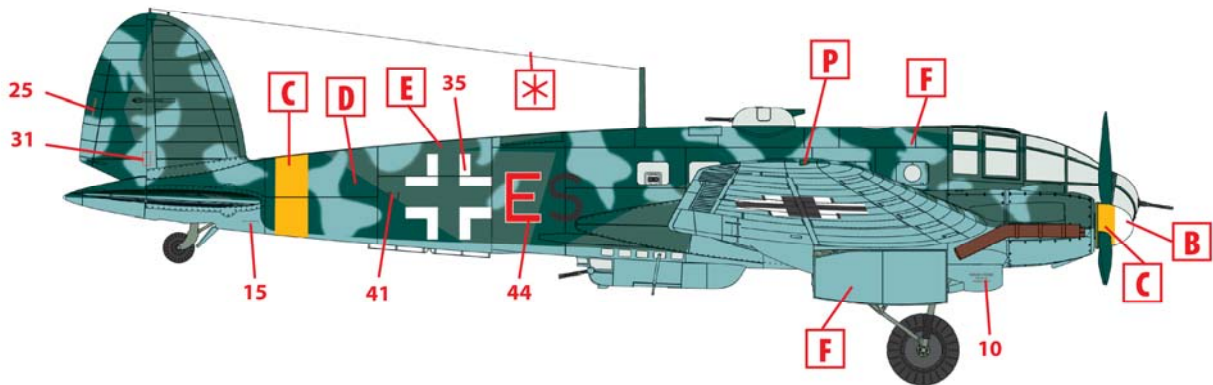
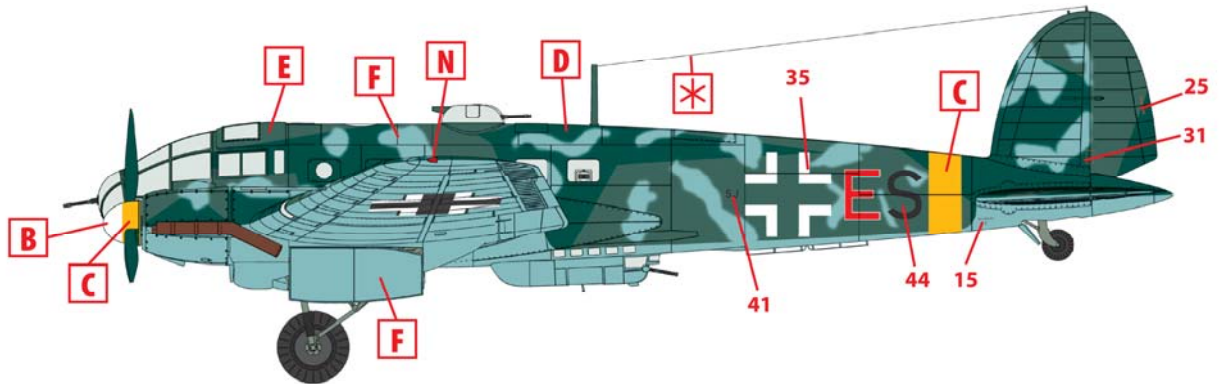

4. He 111H-20, 8./KG 4, аэродром Берлин-Гатов, апрель 1945 г.
 He 111H-20, 8./KG 4, Berlin-Gatow airfield, April 1945