



Classic Airframes



Boulton-Paul

DEFLIANT Mk.I

1/48 SCALE PLASTIC KIT

95-404

PLASTIC PARTS - PP

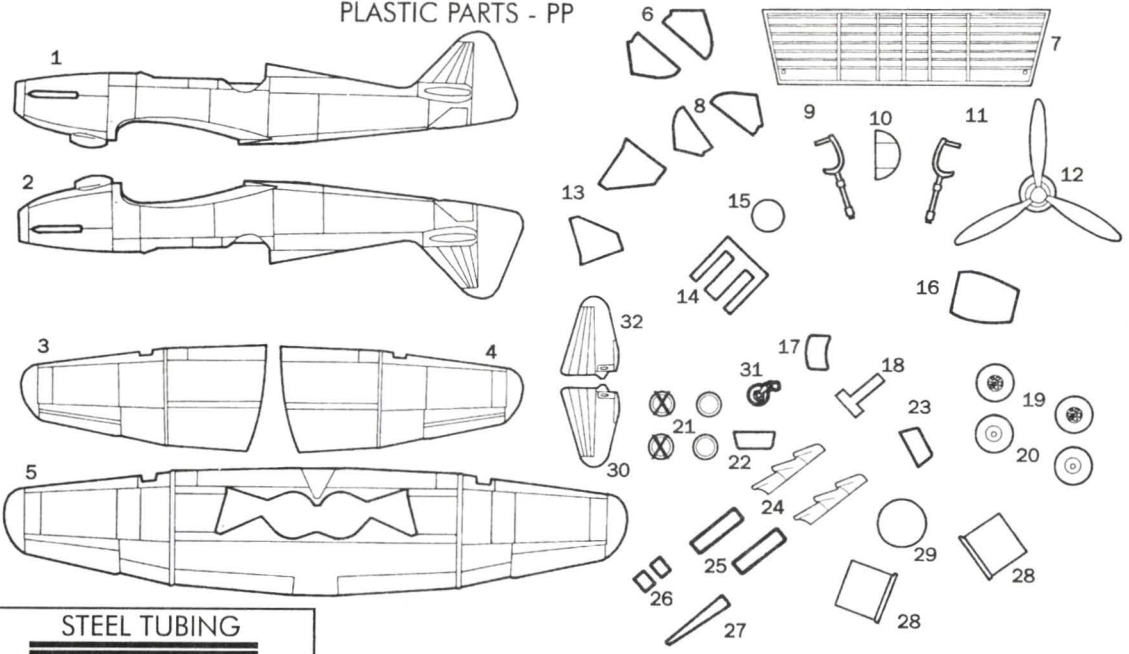

STEEL TUBING

ACETATE PARTS-AC

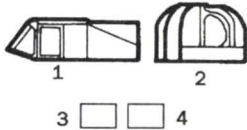

FILM

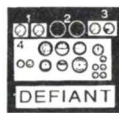

RESIN PARTS-RP

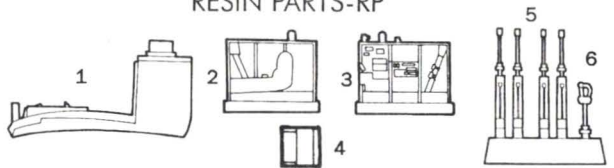
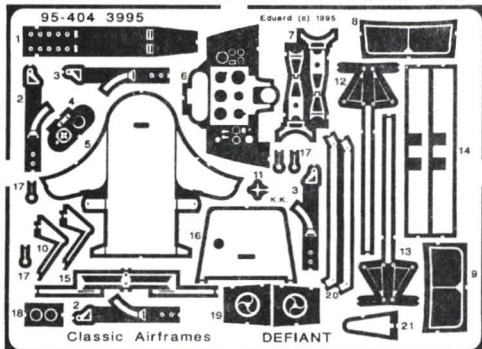
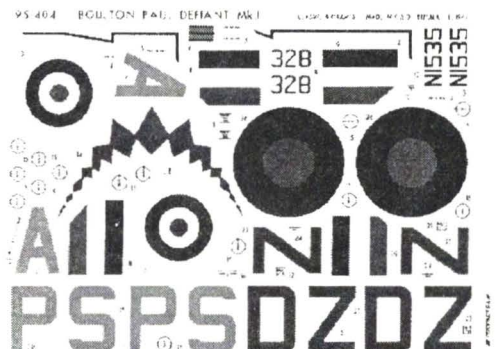

PHOTO ETCHED DETAIL PARTS - PE



DECAL SHEET



NOTE: TO ATTACH PHOTO ETCHED, WHITE METAL AND RESIN PARTS, IT IS RECOMMENDED TO USE SUPER GLUE



OPTIONAL
FACULTATIF
NACH BELIEBEN
VOLBA



BEND
PLIER SIL VOUS PLAIT
BITTE BIEGEN
OHNOUIT



OPEN HOLE
FAIRE UN TROU
OFFNEN
VYVRTAT OTVOR



SYMETRICAL ASSEMBLY
MONTAGE SYMETRIQUE
SYMMETRISCHE AUFBAU
SYMETRICKÁ MONTÁŽ



REMOVE
RETIRER
ENTFERNEN
ODRŽNOUT



A
GREEN
VERT
GRÜN
ZELENÁ



B
BLACK
NOIR
SCHWARZ
ČERNÁ



C
COPPER
CUIVRE
KUPFER
MĚĎ



E
LIGHT GRAY
GRIS CLAIR
HELLGRAU
SVĚTLE ŠEDÁ



F
BROWN
BRUN BOIS
BRAUN
HNĚDÁ



H
ALUMINIUM
ALUMINIUM
ALUMINIUM
HLINÍK

A

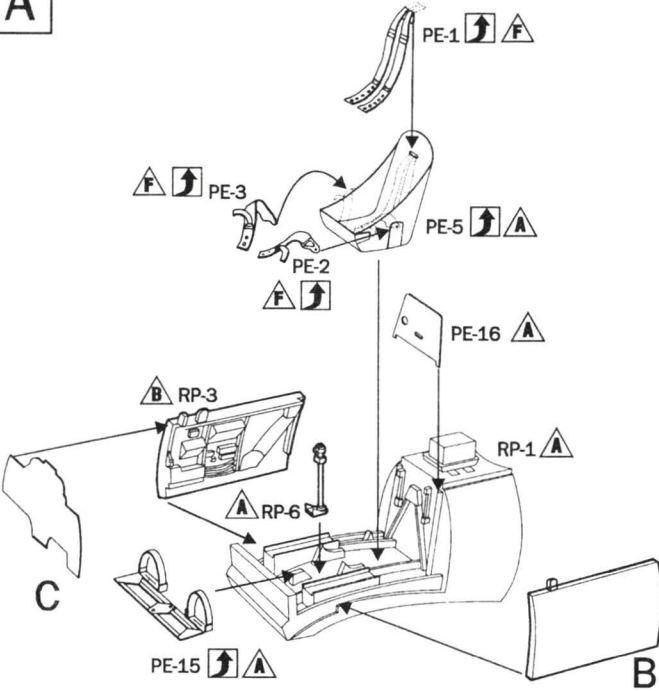

B

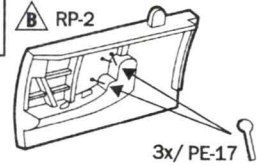

C

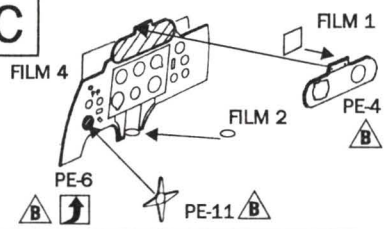

D

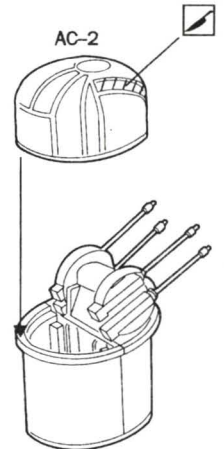
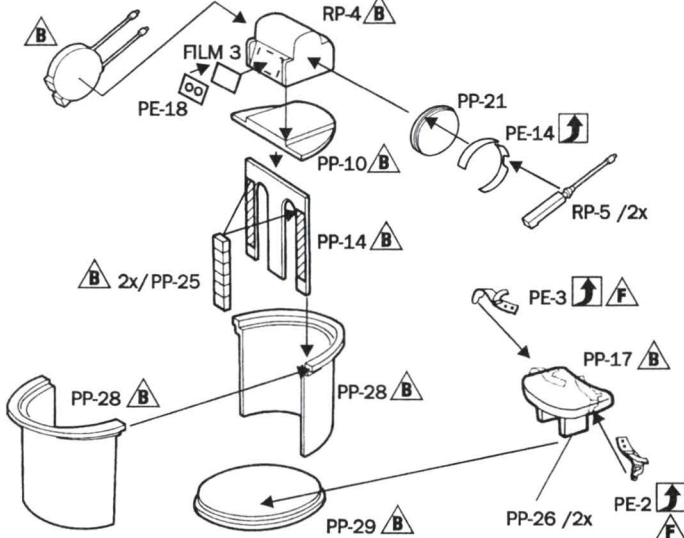

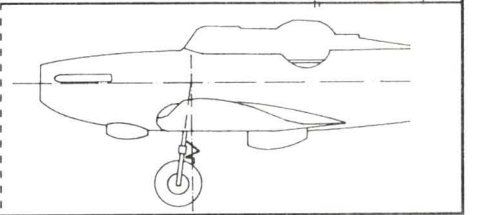
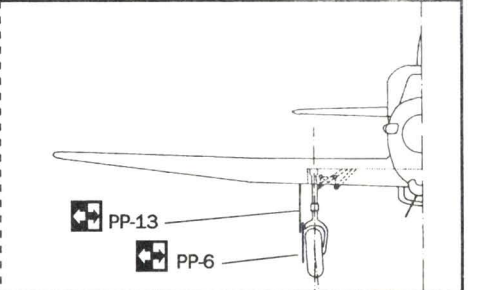
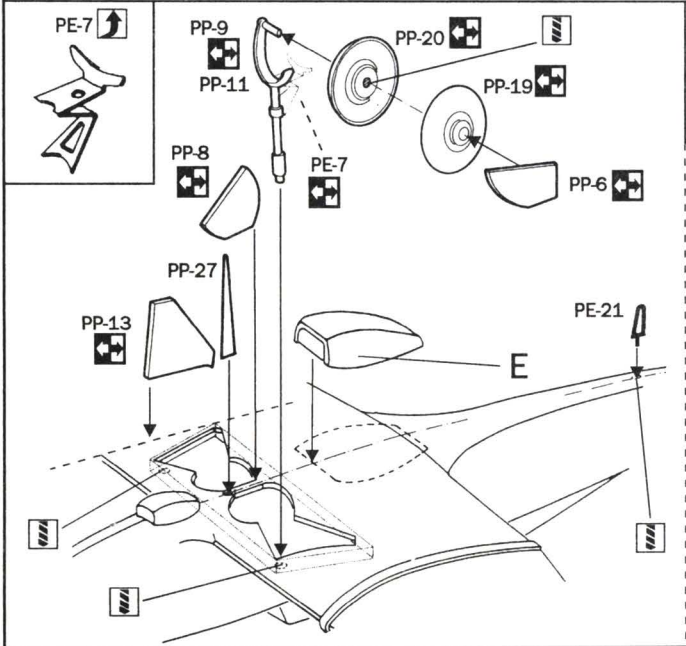
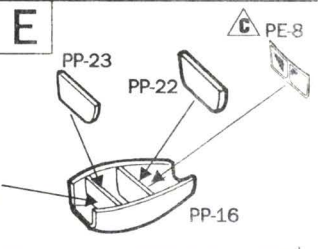
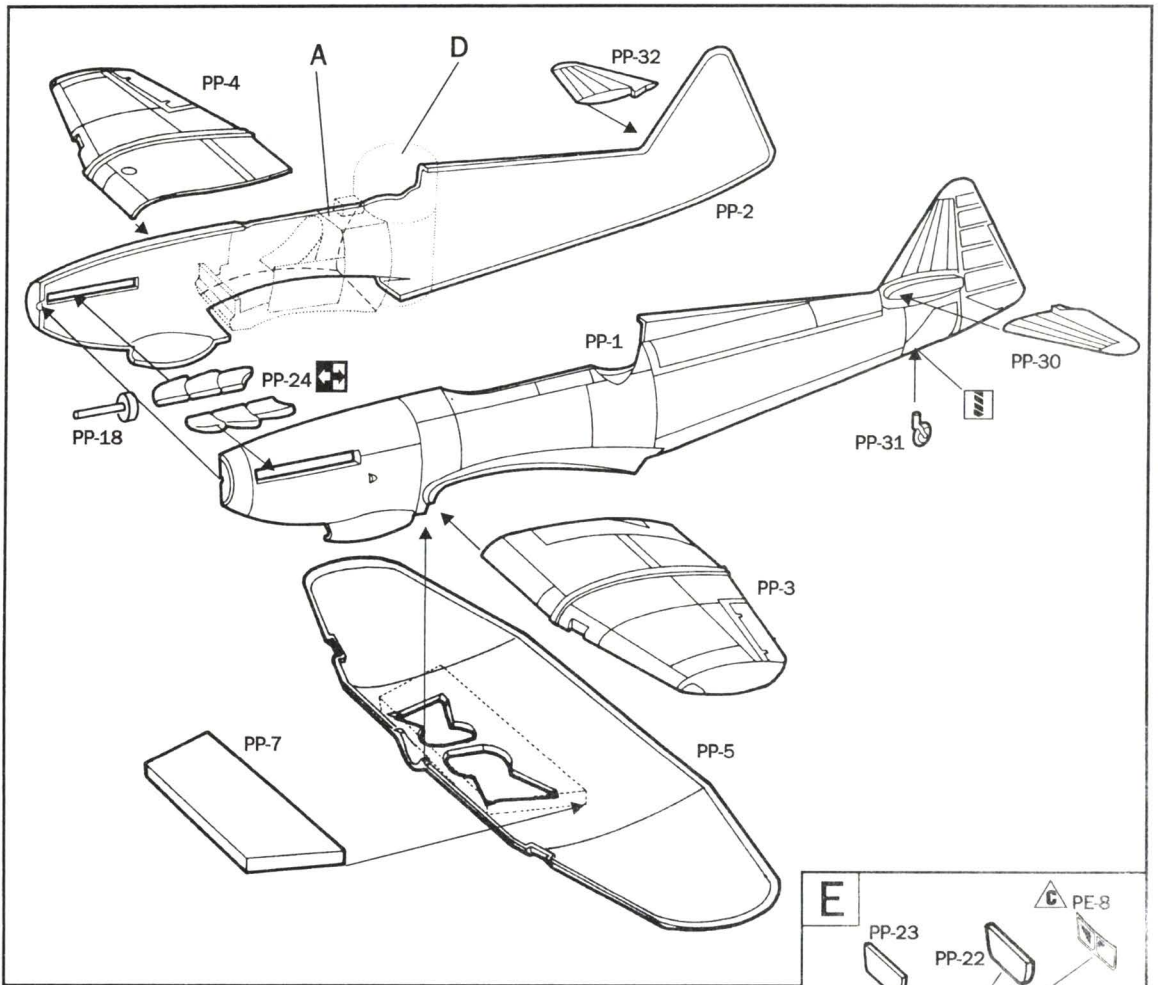

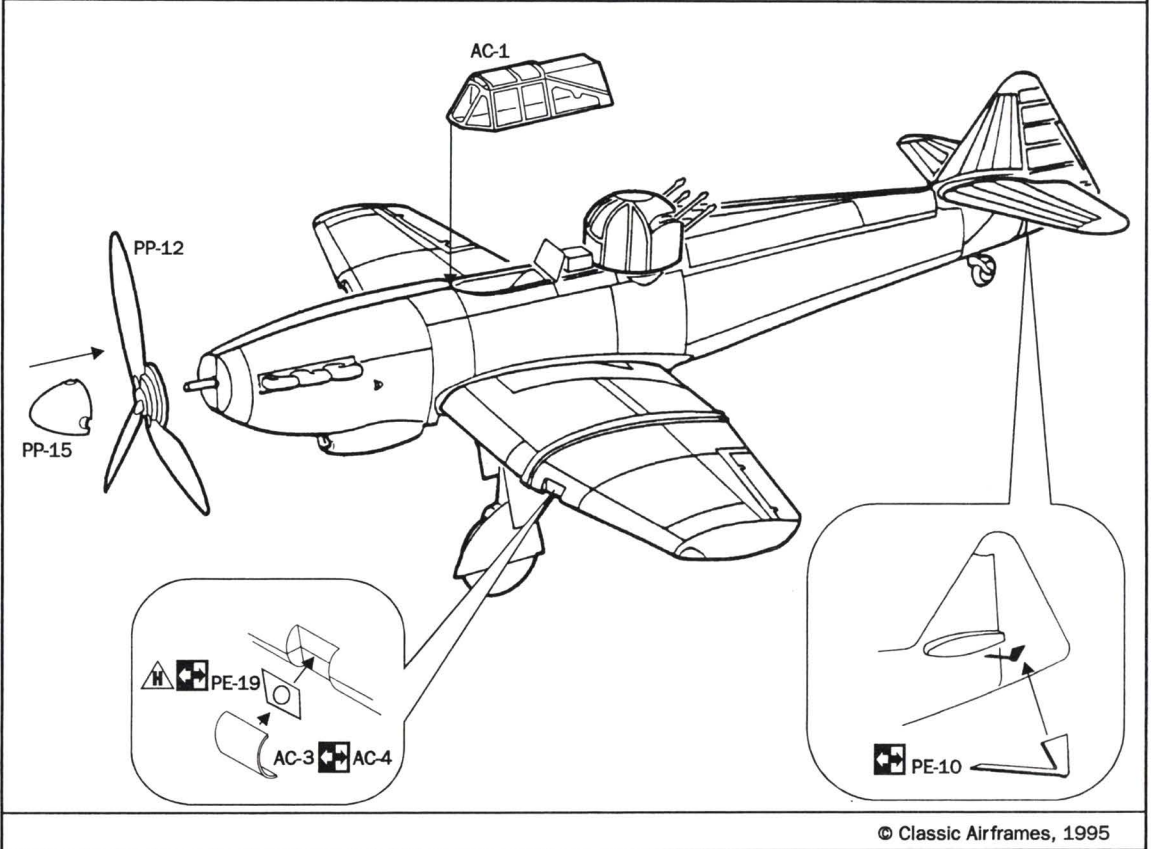
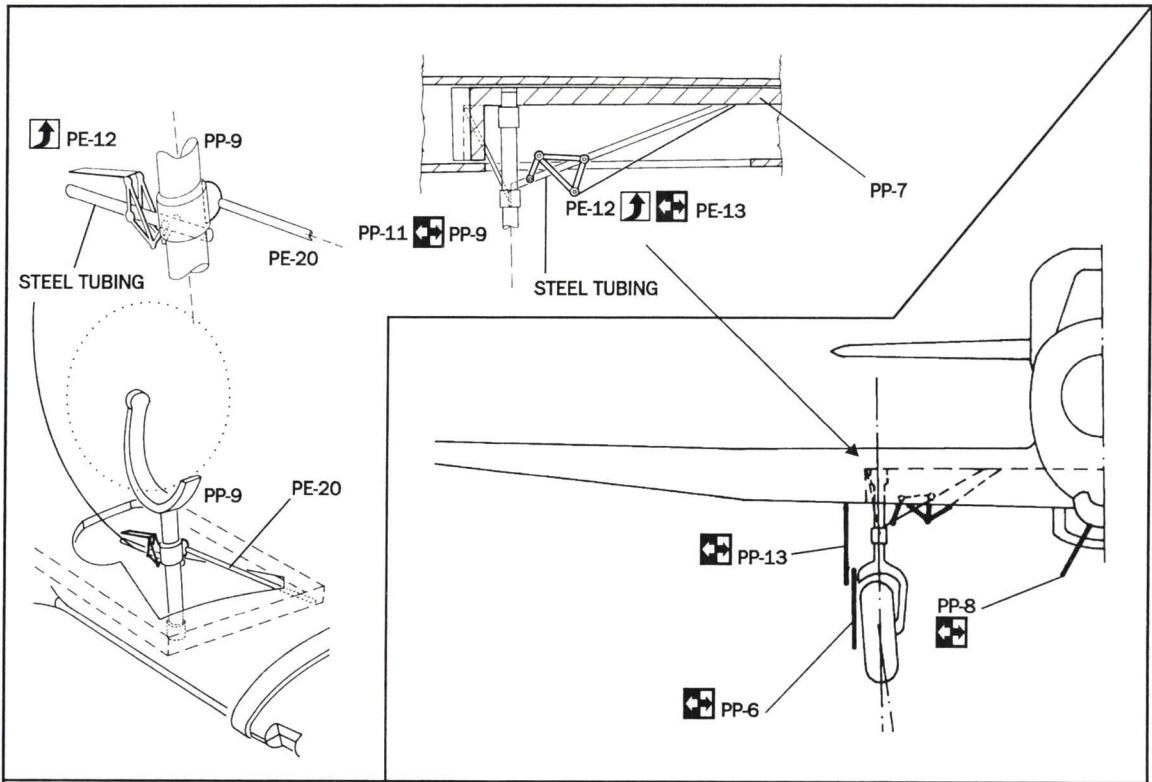

BOULTON-PAUL DEFIANT

In 1935 the Air Ministry issued specifications outlining the requirements for a two-seat day and night fighter. The winner of this contract was Boulton-Paul Aircraft Ltd. The Defiant was born. It flew in mid-1937 when it also officially acquired its name.

It was to be until March 1940, that No. 264 Squadron became operational with the type. The unit quickly scored its first kill, a Ju-88, but when Bf-109's were encountered, Defiant losses mounted quickly. At times during the Dunkirk evacuation, good results were obtained, particularly when flying in mixed formations with Hurricanes, which it resembled in outline. The Luftwaffe however was not confused for very long.

In August 1940 the Defiant was withdrawn from daylight missions and employed primarily as a night fighter, in this role the Defiant fared much better and served well into 1942 until replaced by Beaufighters and Mosquitos.

The Defiant continued to serve in the air-sea rescue role and as a target tug right into the late war period.

Technical data:	Power Plant	one 1030 h.p. Rolls-Royce Merlin III
	Armament	four 0.303 Browning machine guns in power operated turret
	Max. speed	304 m.p.h. at 17000 ft.
	Span	39' 4''
	Length	35' 4''
	Range	465 miles



Classic Airframes



NEXT RELEASE

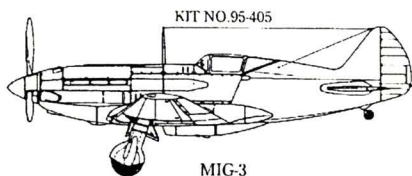

BOULTON-PAUL DEFIANT

PAINTING & MARKING GUIDE

95 404

A. Mk.I N3328, 151 Sqn., 1941

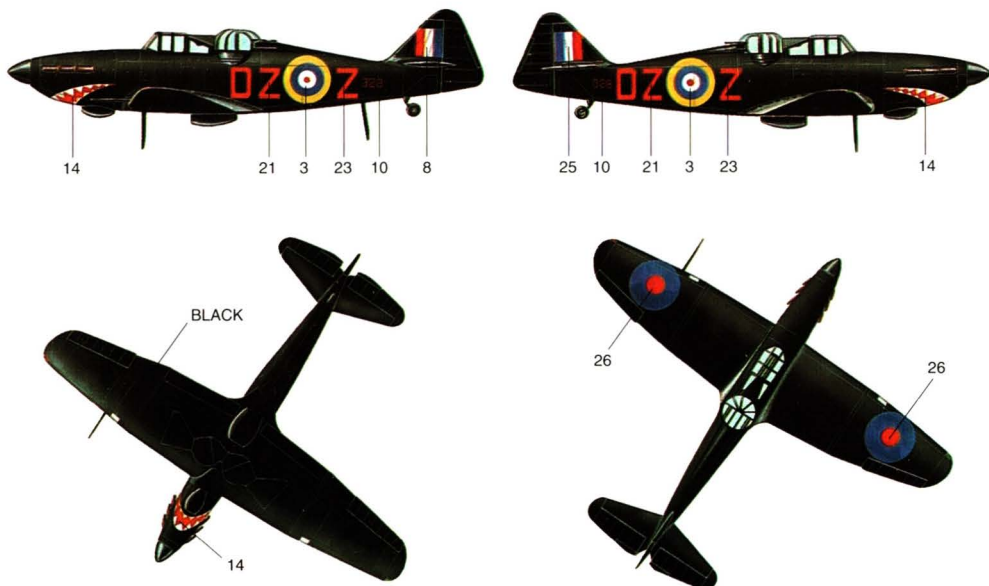

B. Mk.I N1535, 264 Sqn., mid-August 1940

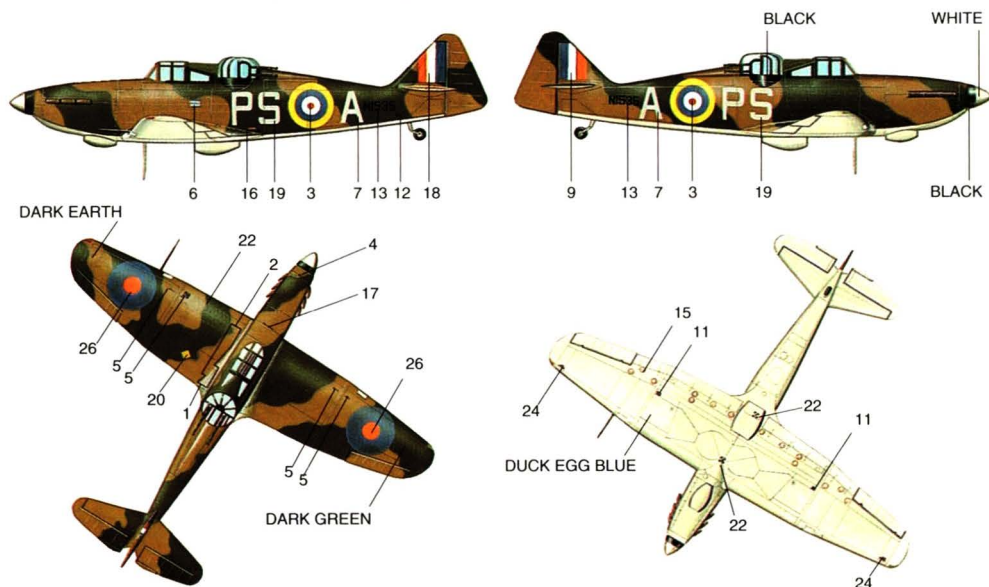

95-404

BOUTON PAUL DEFIANT Mk.I

CLASSIC AIRFRAMES MADE IN CZECH REPUBLIC (c)1995

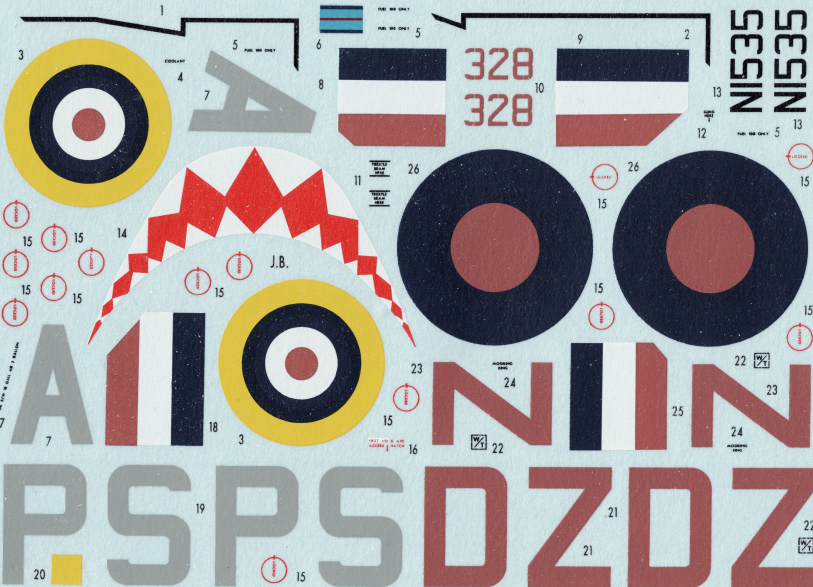

PROFACTEAM