

JAGDPANZER IV L/48 [EARLY]

◆ READY TO ASSEMBLE PRECISION MODEL KIT ◆ MODELING SKILLS HELPFUL IF UNDER 14 YEARS OF AGE ◆ MODEL MAY VARY FROM IMAGE ON BOX ◆ CEMENT AND PAINT NOT INCLUDED

德国四号歼击车L48 初期型

ドイツ軍 IV号駆逐戦車 L/48 初期生産型



TREX

Designed by
T-Rex Studio
in China

1/35
SCALE
BT-016

◆ PE PARTS INCLUDED.
◆ 3 TYPES OF MOUNTED BRACKET ARE INCLUDED.

Border



The JAGDPANZER IV was initially intended to be fitted with the PaK42 70x 75mm gun. This gun, originally fitted to the Panther medium tank, was very powerful and could penetrate to a depth of 174 mm. However, due to limited production and the priority given to the Panther, other guns had to be chosen.

The final scheme was finalized in December 1943 and production began the following January. The first JAGDPANZER IVs were fitted with the PaK 39 L48 75mm gun, which was also used in the later Stug III and Panzer IV, and had a similarly impressive striking capability, although it lacked armor-piercing capability against Allied heavy tanks. There were also a small number of installations of the PaK 39 L43 75mm gun, which had a further reduced hitting capability, but was about as flexible as the Stug III and Stug IV.

This version of the JAGDPANZER IV was almost identical to the Stug III \ Stug IV in all respects except that it had stronger frontal defense. Some senior officers believed this would boost production and also intended to abandon production of the Panzer IV altogether. Production of the model fitted with the PaK42 gun began in August and continued until April 1945, this model having the greatest striking capability.

Compared to other armored weapons, the JAGDPANZER IV had some problems regardless of which version it was mounted. The version with the L48 gun had a muzzle brake installed because it would raise huge dust and smoke every time the gun was fired and would be exposed as soon as the gun was fired, and the brake had to be removed later. When the muzzle brake was removed, the gun would generate huge recoil and the vehicle would shake violently.

These JAGDPANZER IVs served and performed better on both the Eastern and Western fronts. It participated in the Normandy campaign, the Battle of the Bulge, and many battles on the Eastern Front. Tactically speaking the vehicle had to be used with extra care and strict adherence to tank destroyer operating procedures due to the lack of a turret and the overall decline of the German army in the late war. However, the lack of tanks forced the Germans to use these turretless assault guns and Jagdpanzers as tanks in many cases, but their poor battlefield agility led to massive losses. When the tactics were right, the higher military education of the German soldiers and the superiority of the artillery often led to excellent results. For example, Rudolf Roy of the "Hitler Youth" Division was in command of the JAGDPANZER IV. Roy commanded it and achieved a record of 36 kills, plus some unconfirmed results.

JAGDPANZER IV 一开始准备安装PaK42型70倍径75毫米炮。这门原本在“黑豹”中型坦克上配备的火炮威力巨大，其穿甲深度可达到174毫米。但是由于产量有限，而且要优先供给给Panther使用，所以最后只能选择其他火炮。

最终的方案在1943年12月定型，于次年1月开始生产。第一批JAGDPANZER IV安装的是PaK 39型48倍径75毫米炮。这门火炮同样用在后期三号突击炮和四号坦克，打击能力同样可观，不过对战盟军的重型坦克时穿甲能力不足。还有少部分安装了PaK39型43倍径75毫米炮，打击能力进一步降低，但是作战灵活度和Stug III \ Stug IV差不多。

这一型号的JAGDPANZER IV除了正面防御更强之外，其他方面与Stug III \ Stug IV几乎相同。一些高层军官认为这样能够提升产量，还打算彻底放弃四号坦克的生产。安装PaK42型火炮的型号在8月开始生产，并一直生产到1945年4月。这一型号的打击能力最强。

相比于其他装甲兵器，四号坦克歼击车不管哪个版本都有一些问题。安装48倍径火炮版本的因为安装有炮口制退器，每次开炮时都会掀起巨大的尘烟，一开炮就会暴露。后来不得不拆除制退器。拆除制退器后开炮会产生巨大的后坐力，车体晃动剧烈。

这些JAGDPANZER IV服役后，在东、西两线都有较佳表现。它参加了诺曼底战役、突出部战役以及东线的许多战役。从战术上来讲该车因为没有炮塔以及德军在战争后期整体上表现出的颓势，在使用时必须格外注意，必须严格遵守坦克歼击车的操作程序。但是缺乏坦克的德军许多时候不得不让这些无炮塔的突击炮、歼击车充当坦克，但是因为它的战场灵活性太差导致了大量损失。在战术得当的时候，依靠德军士兵更高的军事素养以及火炮优势，常常能够取得极佳的战果。例如“希特勒”青年师的鲁道夫·罗伊就指挥四号坦克歼击车取得了36辆的击杀记录，另外还有一些没有确认的战果。

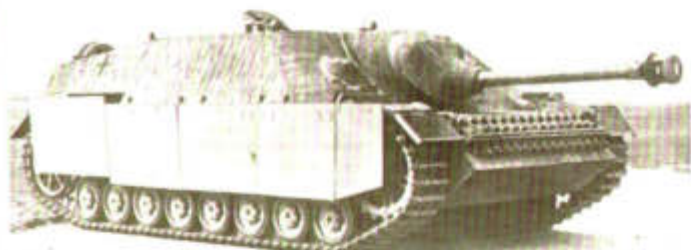

*Pz. 38iger 39 mit PaK 39
Kal. 7,5cm L/48*



部品圖 Parts

Ba x2

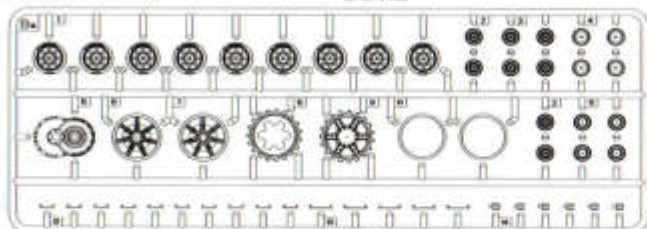

Bb x2

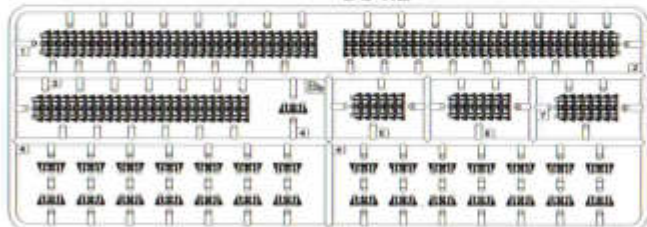

D

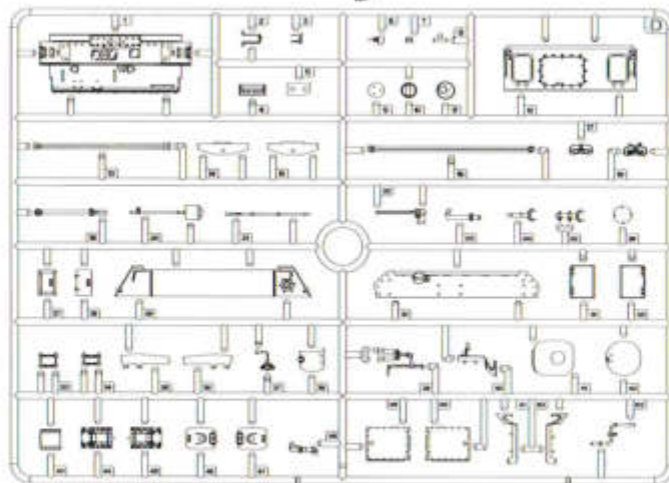

F x 2

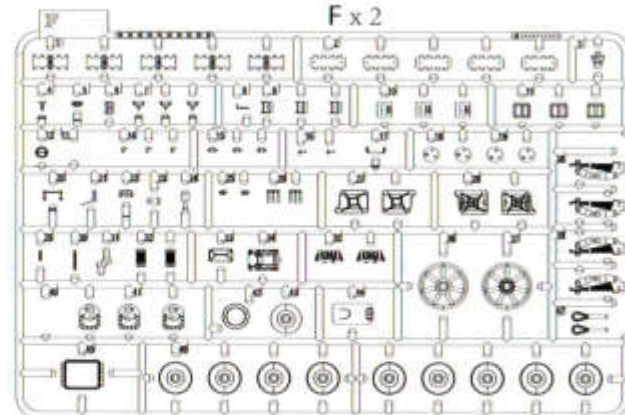

E

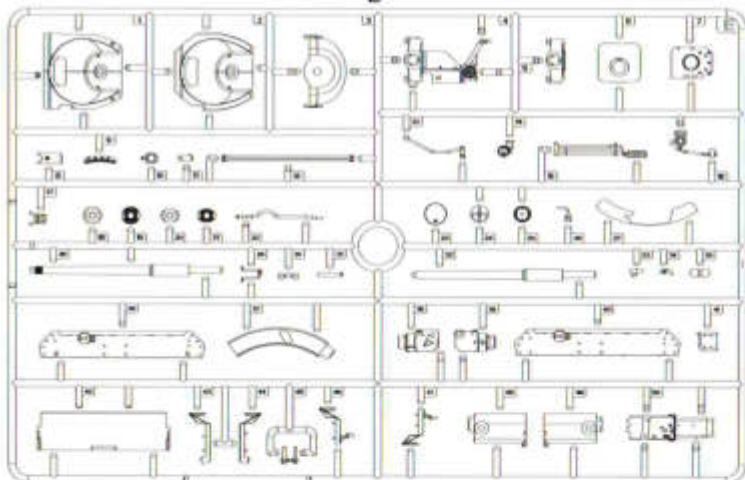

Mc x2

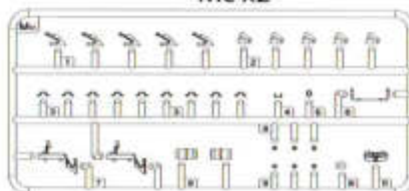

Mb x2

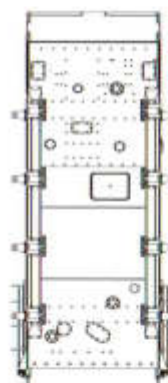
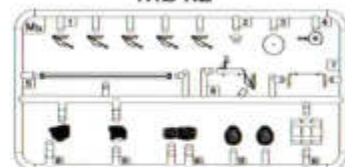

Ob

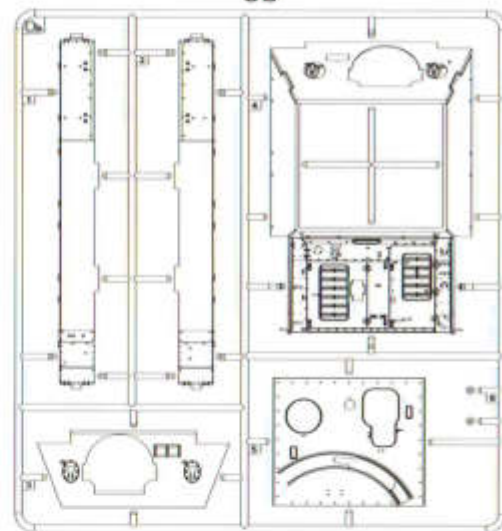

J

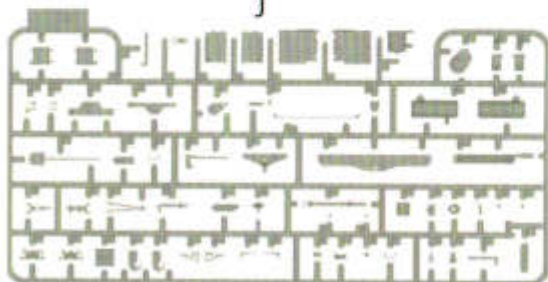

Decal

244 244
313 313
+ +

PE



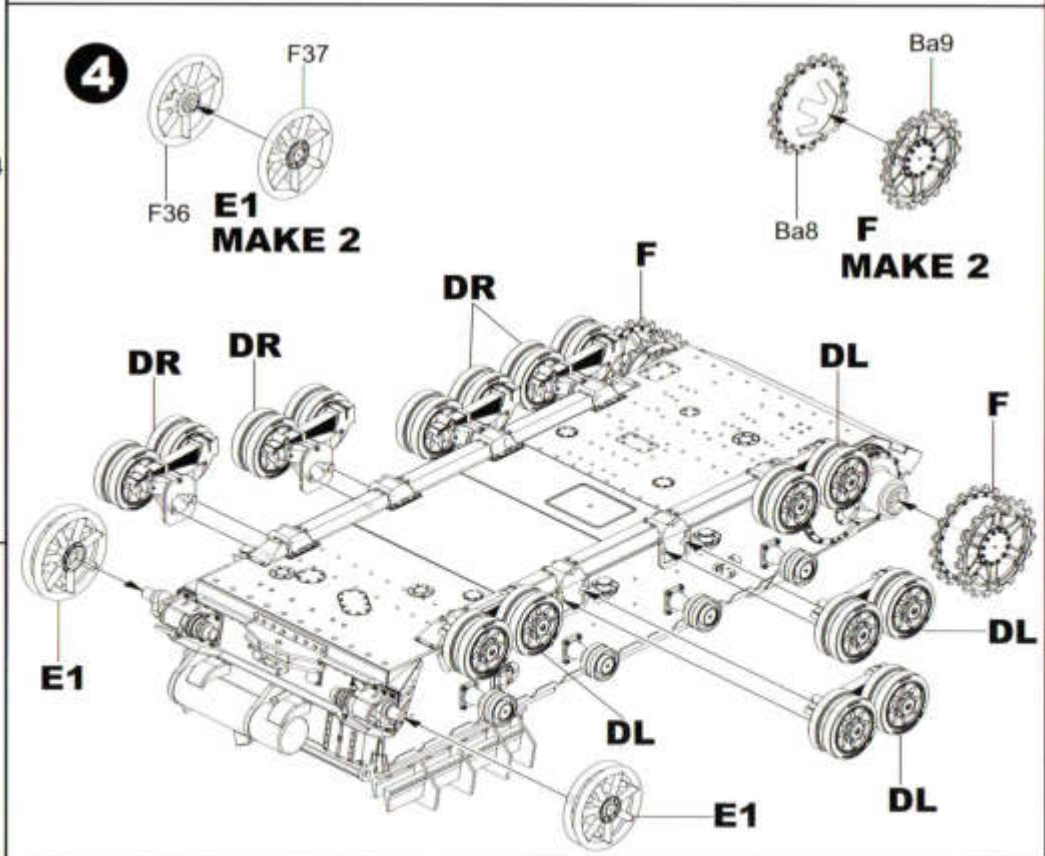
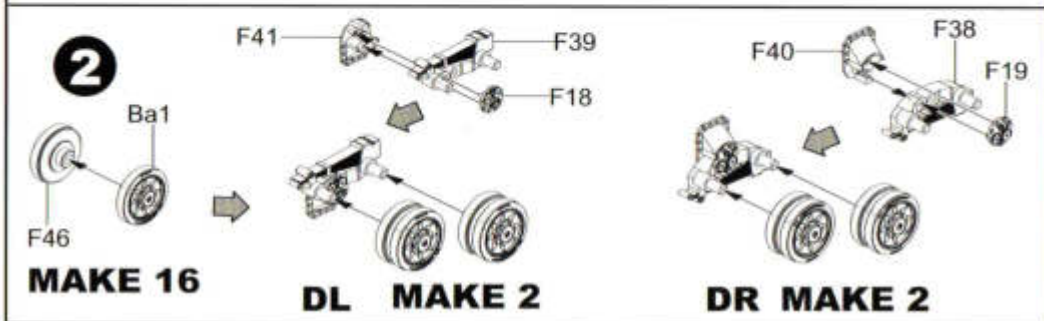
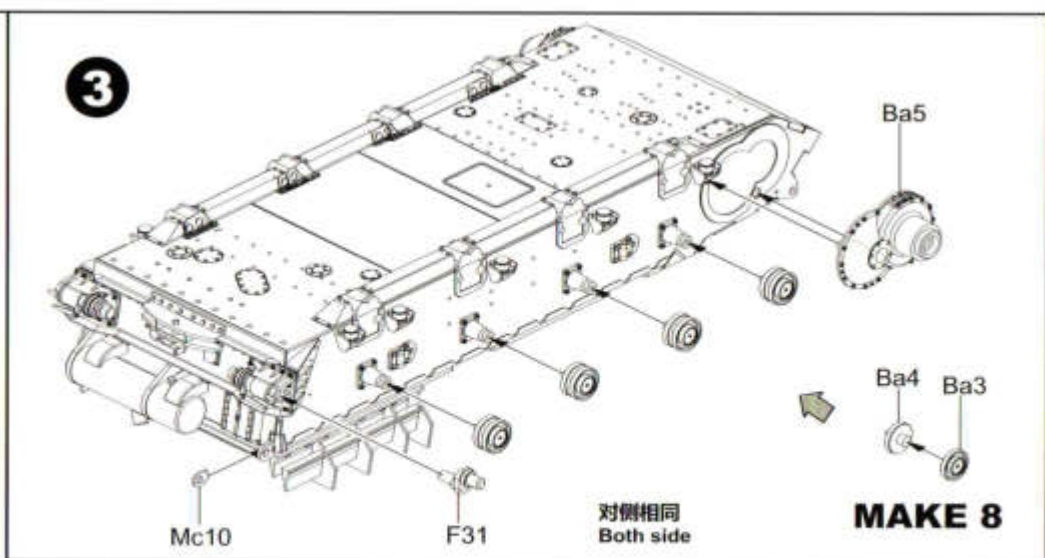
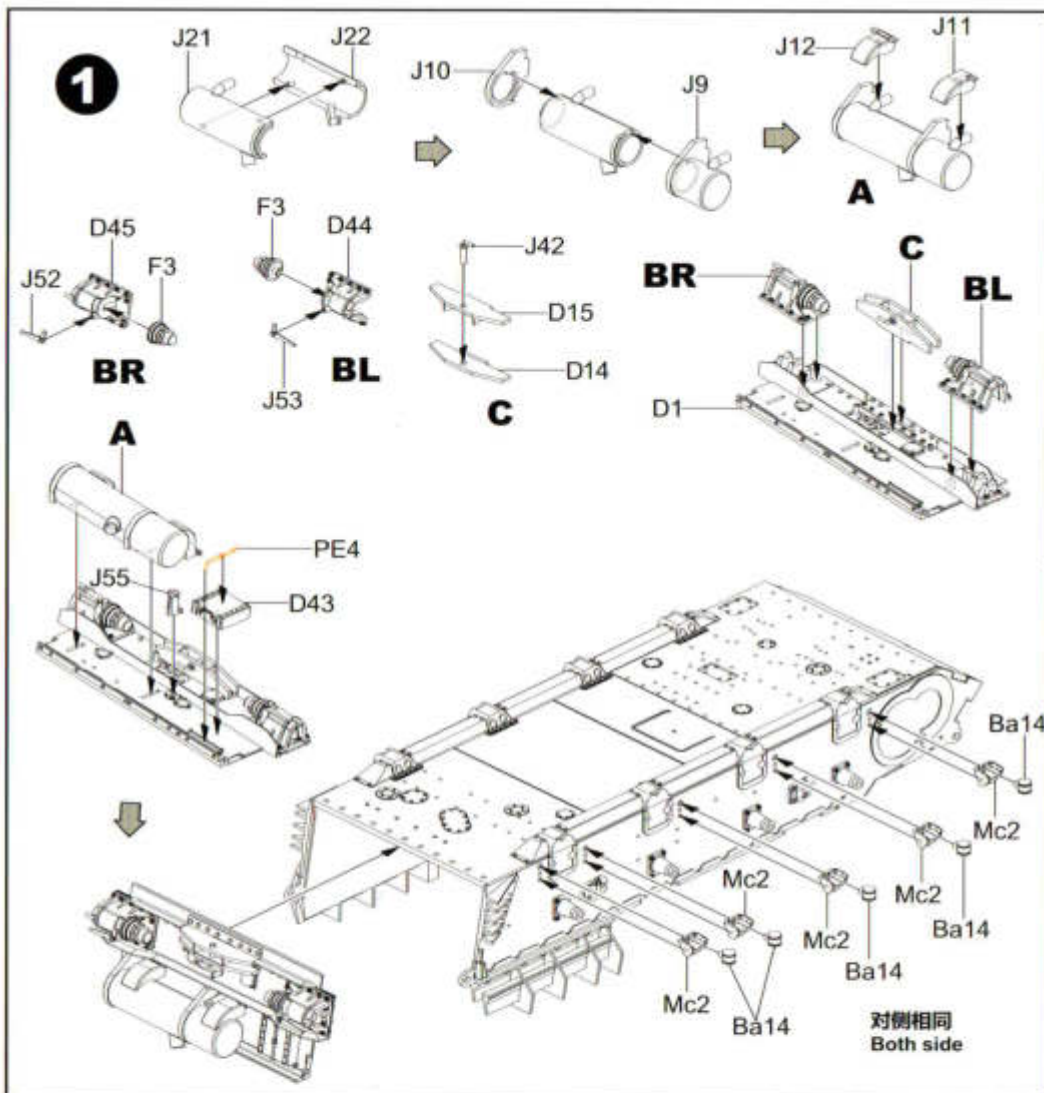

5

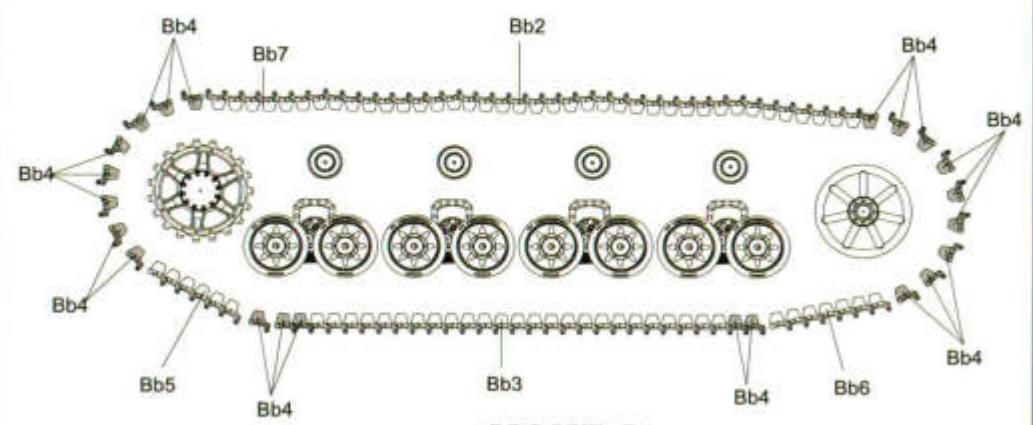
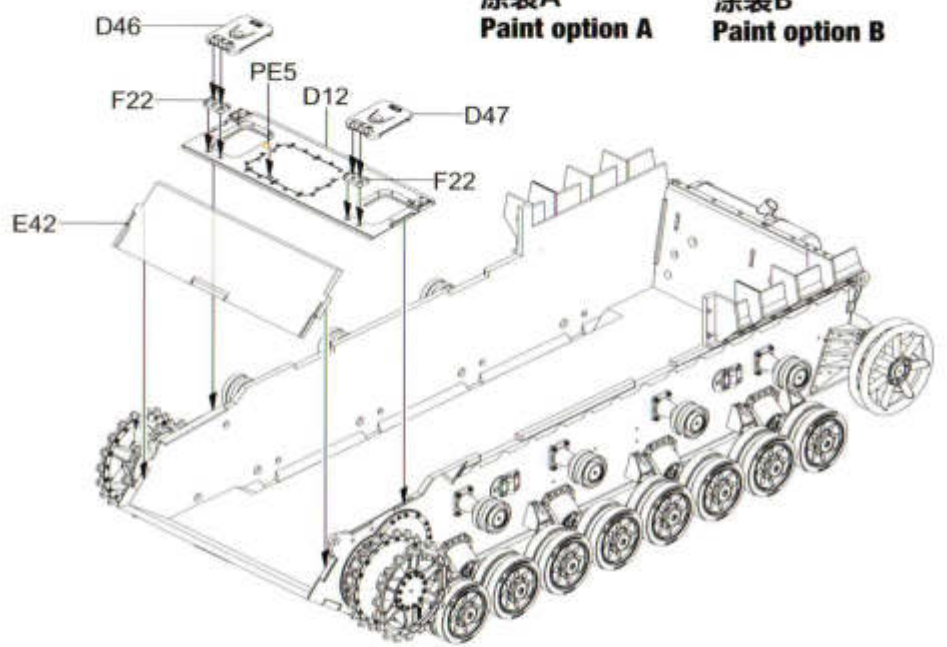
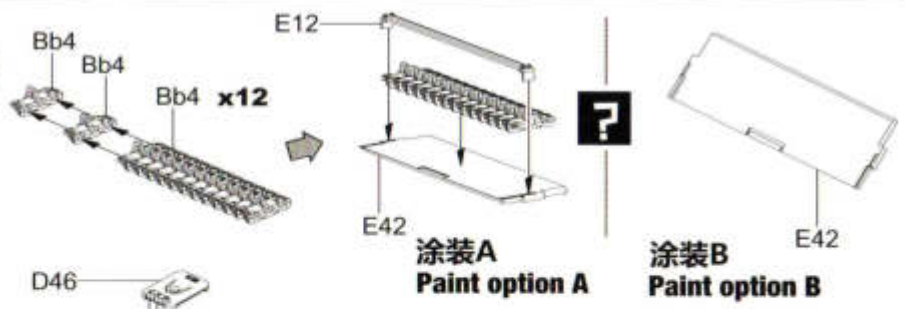

MAKE 2

6

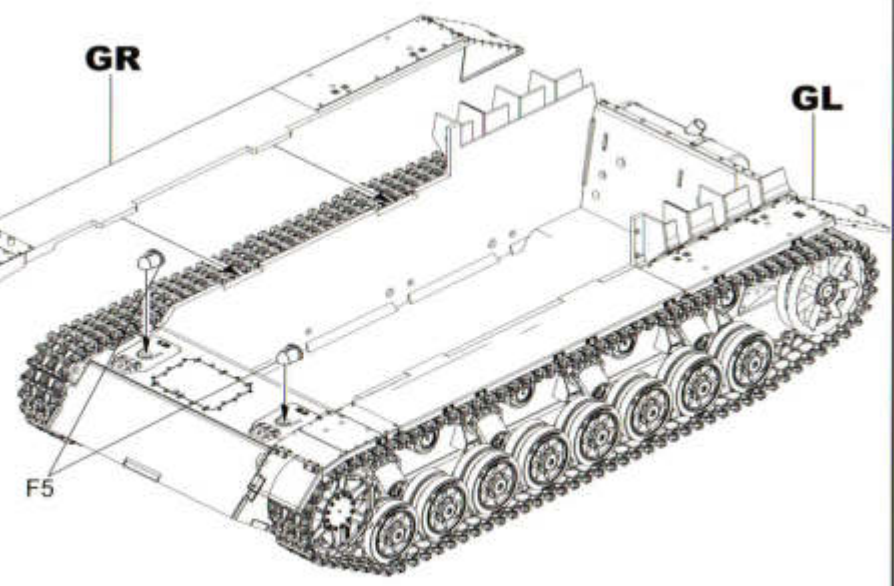
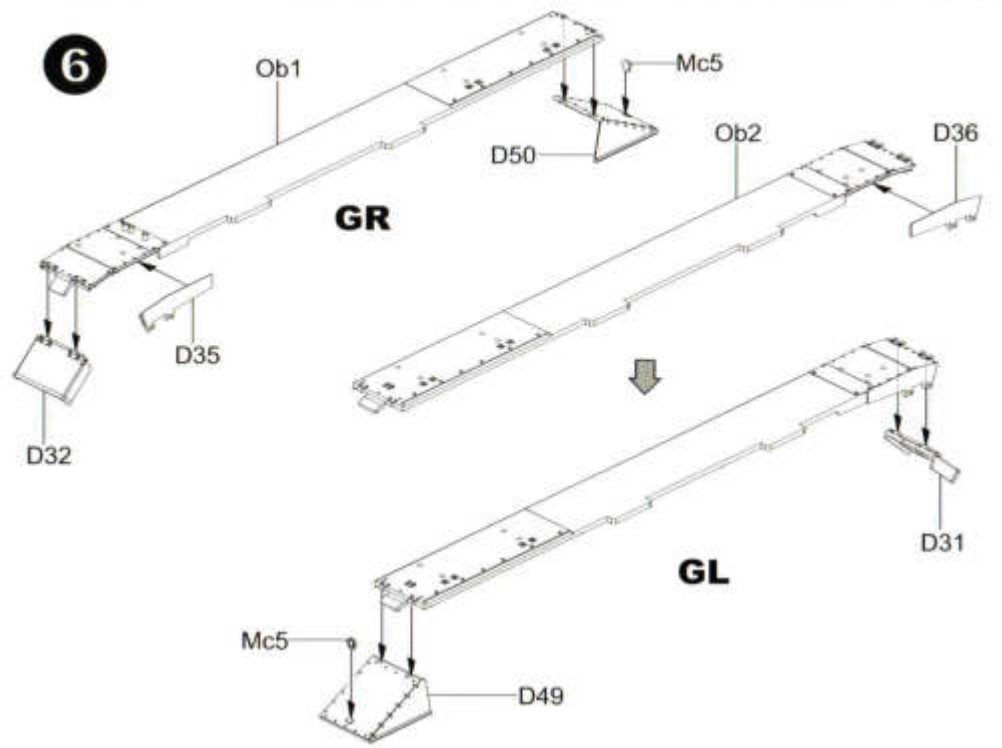

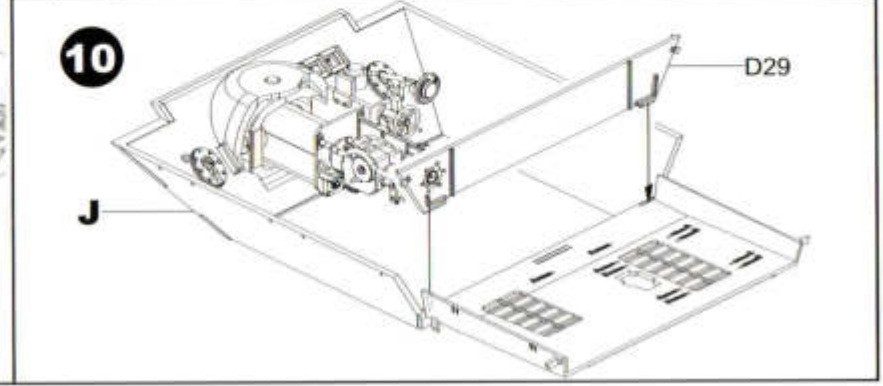
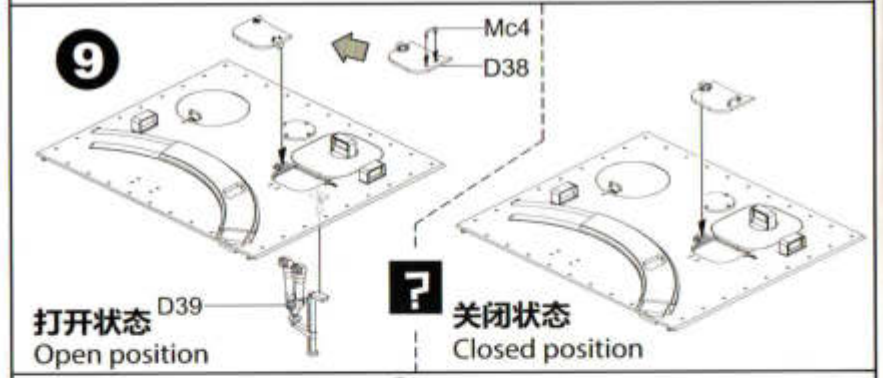
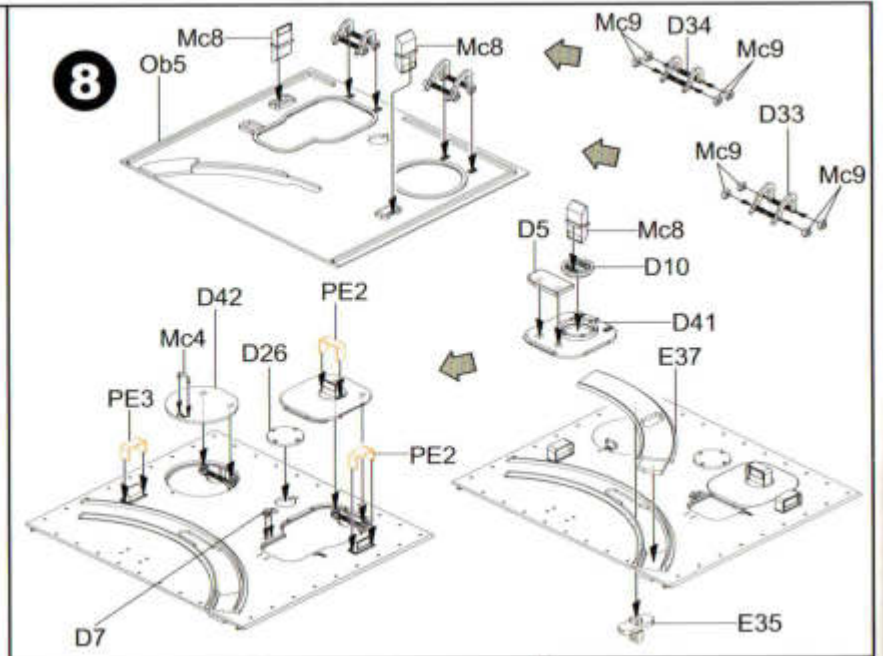
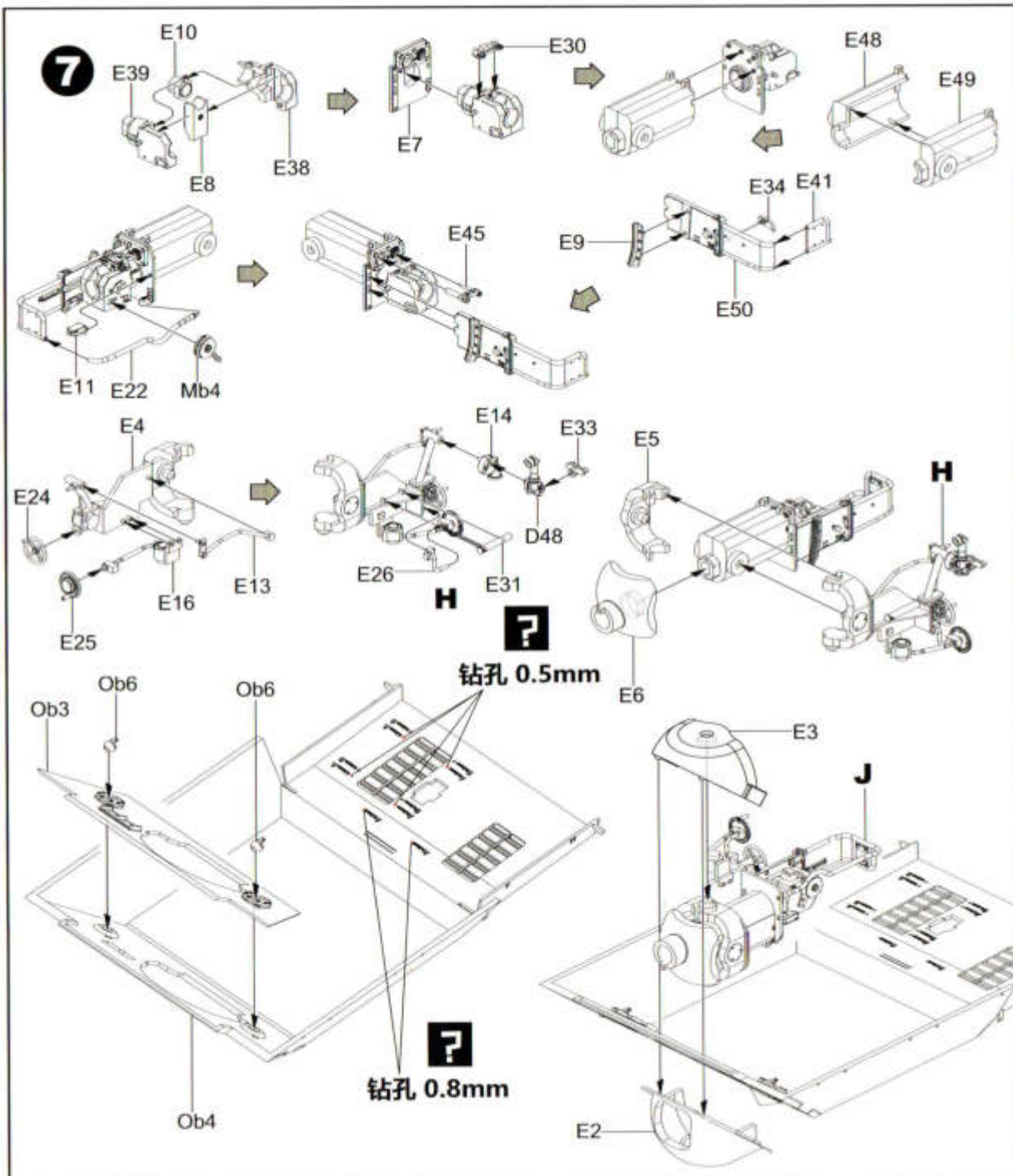

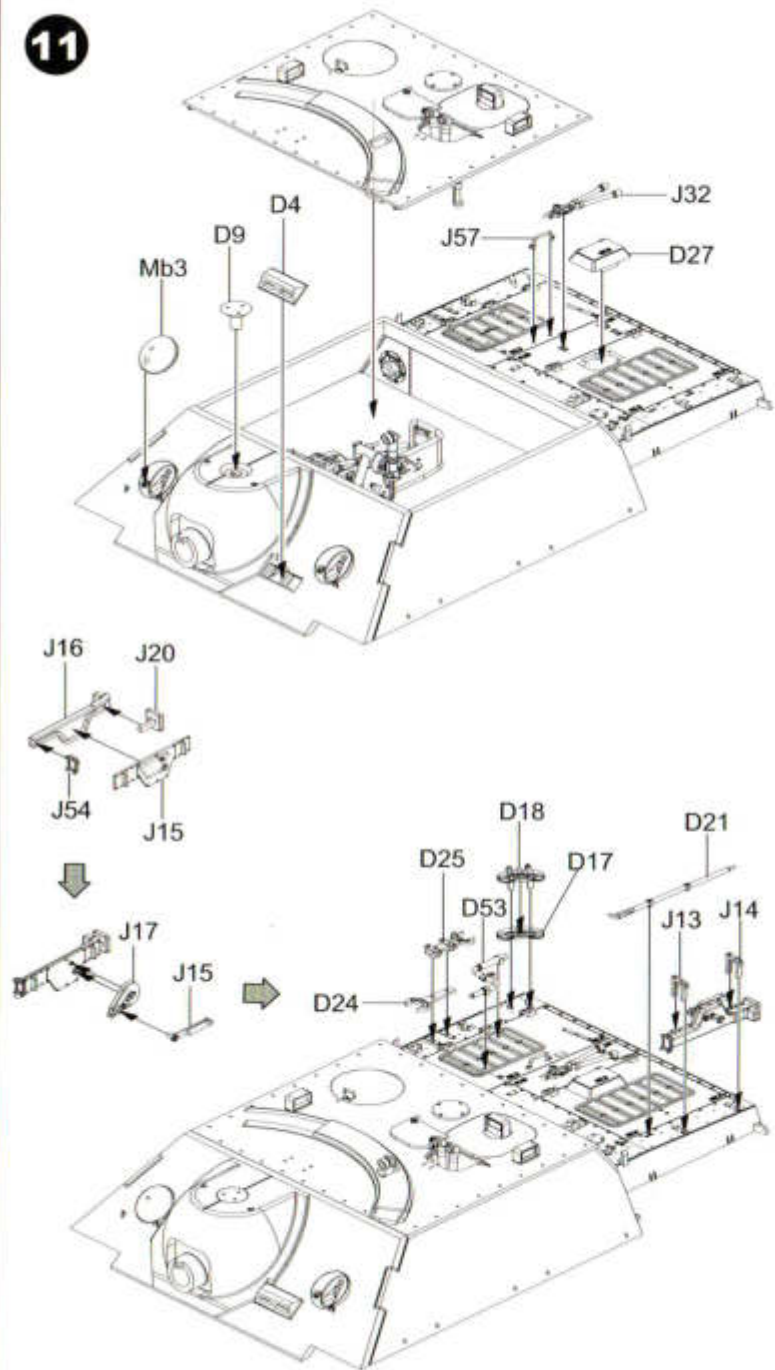
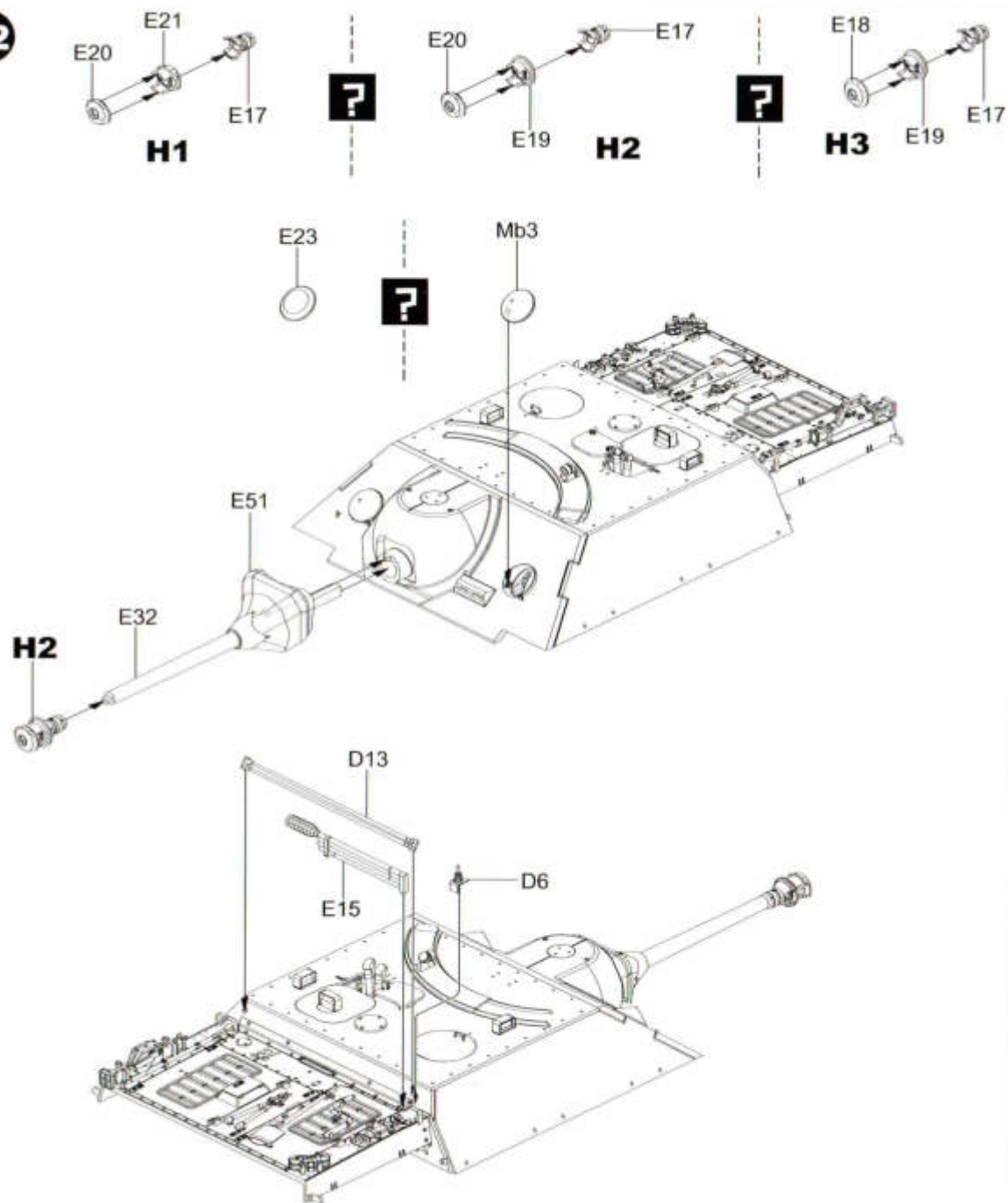
11**12**

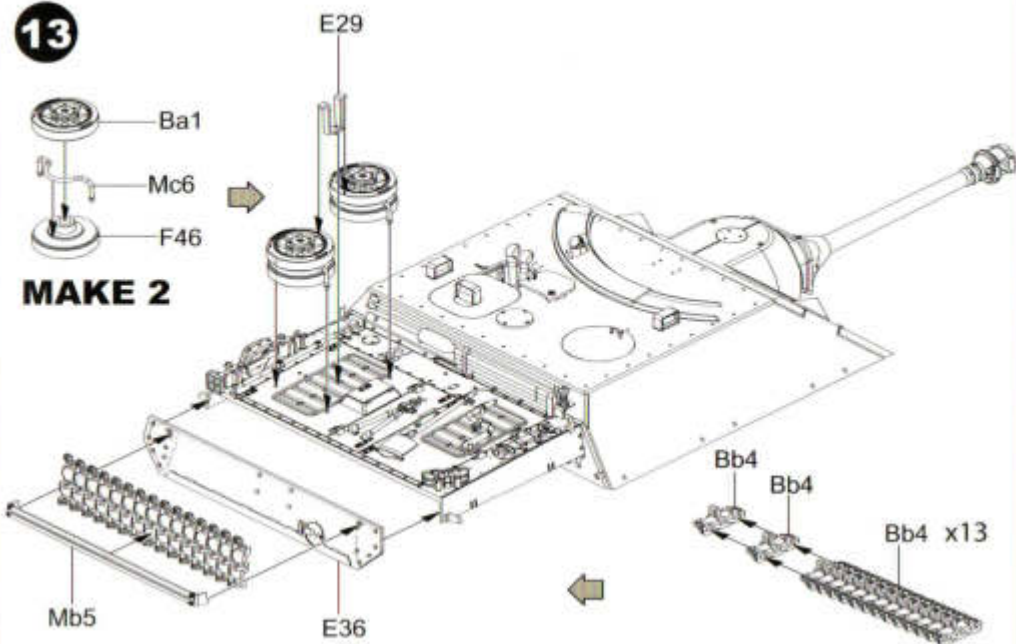
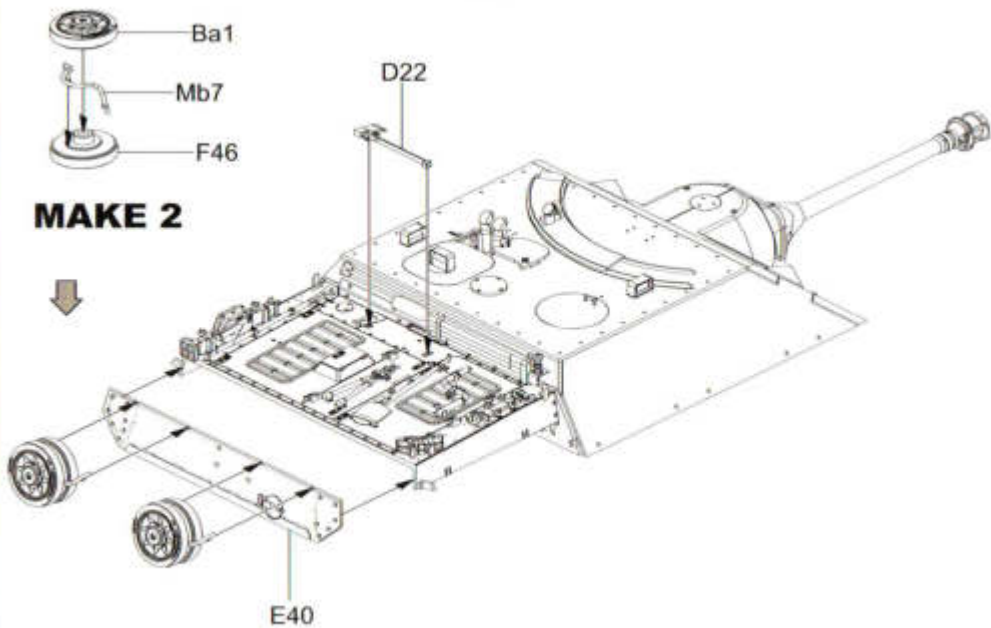
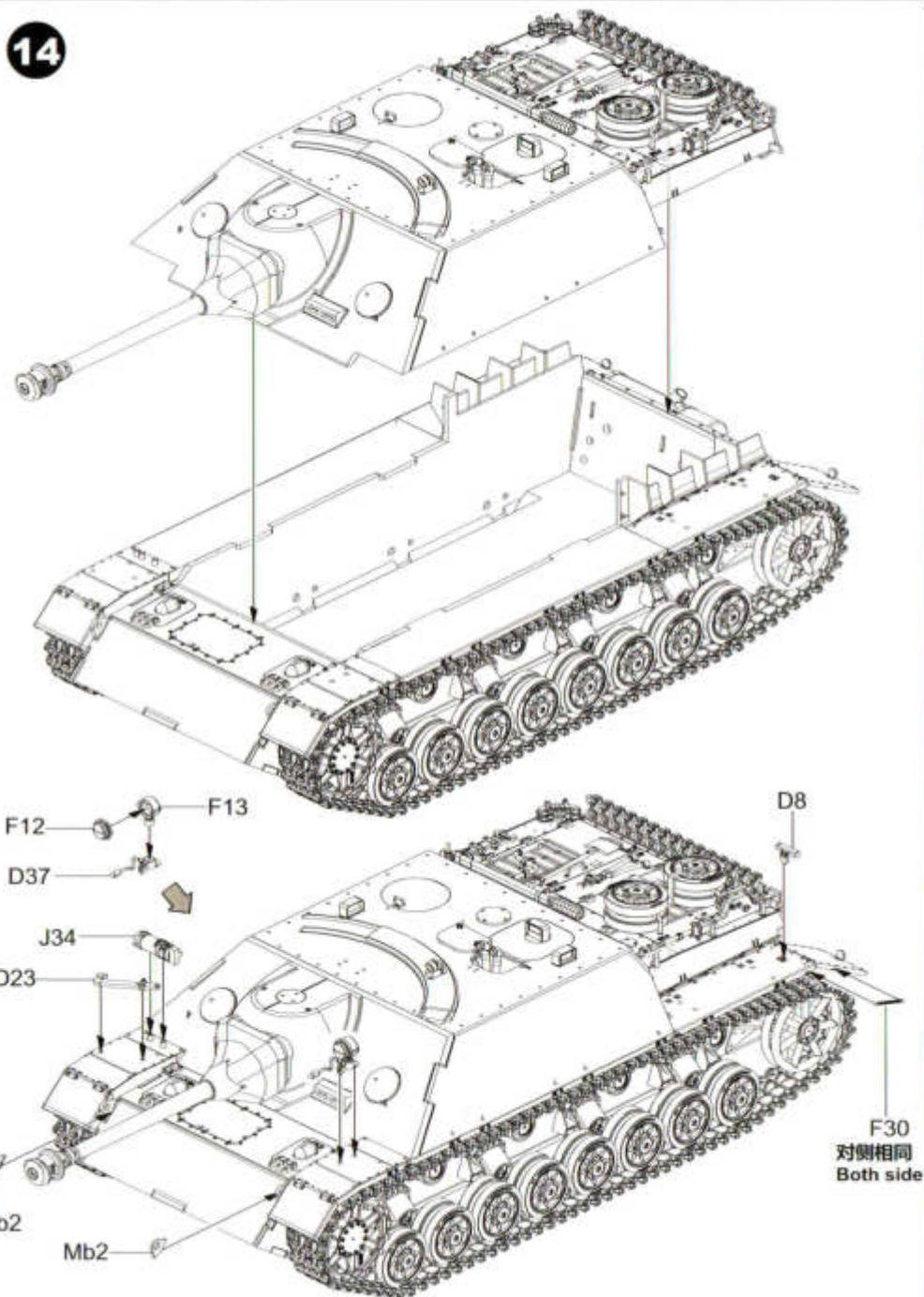
13**MAKE 2****?****MAKE 2****14**

F30
对侧相同
Both side

15

对侧相同 Mb6
Both side

E43 ↔ E44

E46 ↔ E47

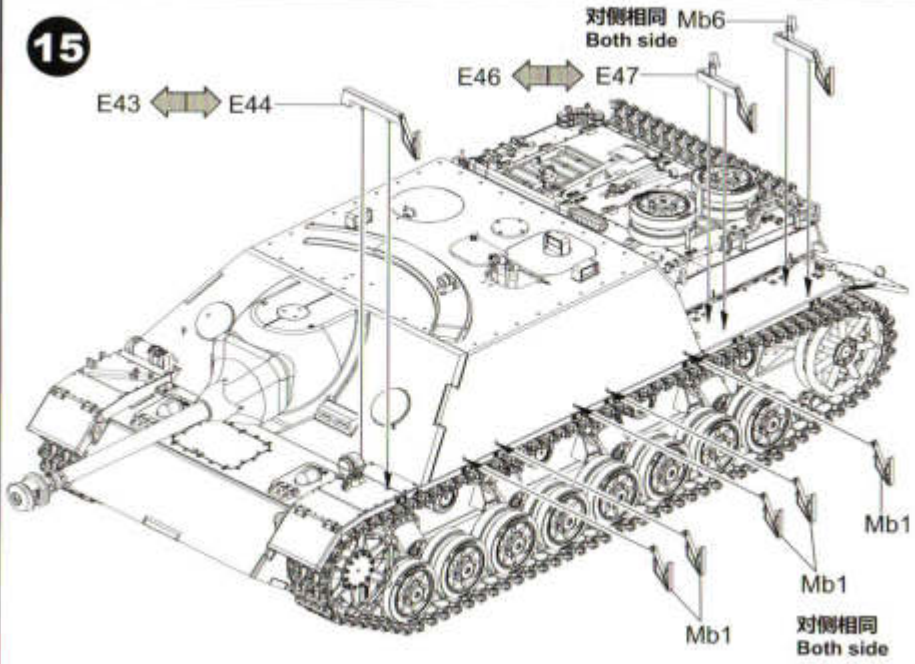

Mb1
Mb1
对侧相同
Both side

16

PE11
↕
PE10

D19

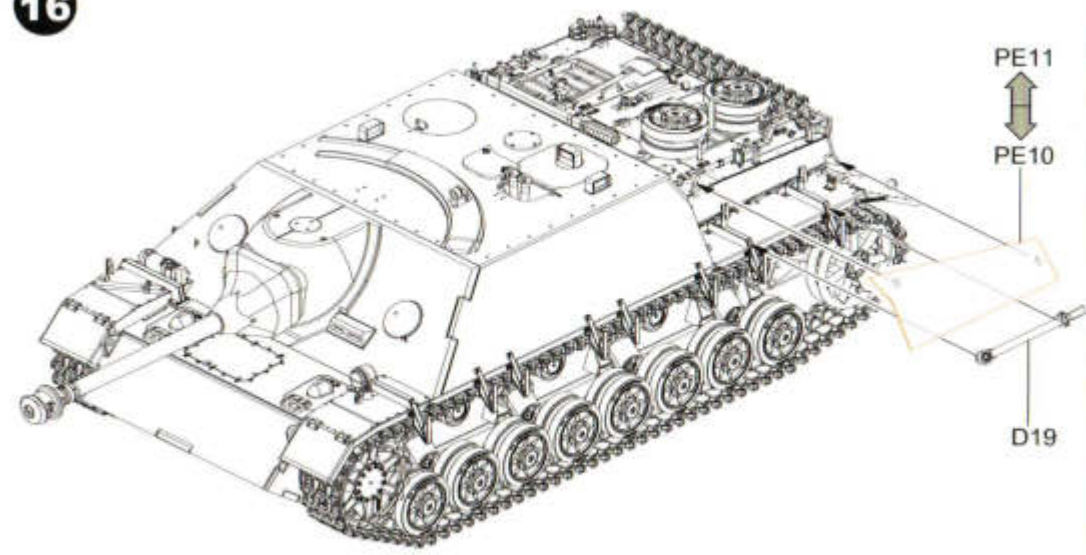

?

对侧相同 Mc7
Both side

D52 ↔ D51

Mc7 ↔ D40

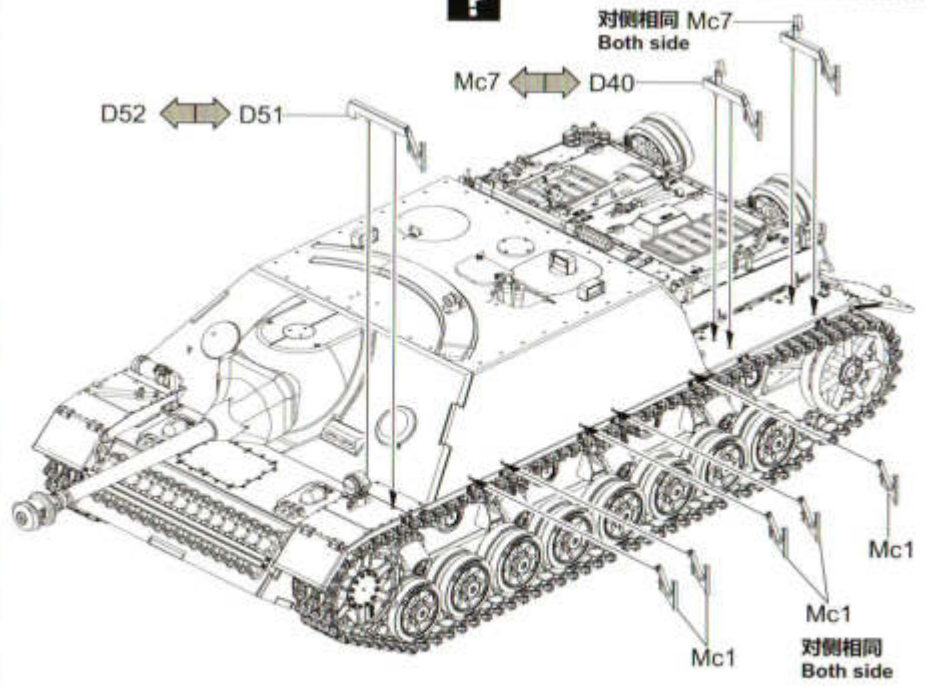

Mc1
Mc1
对侧相同
Both side

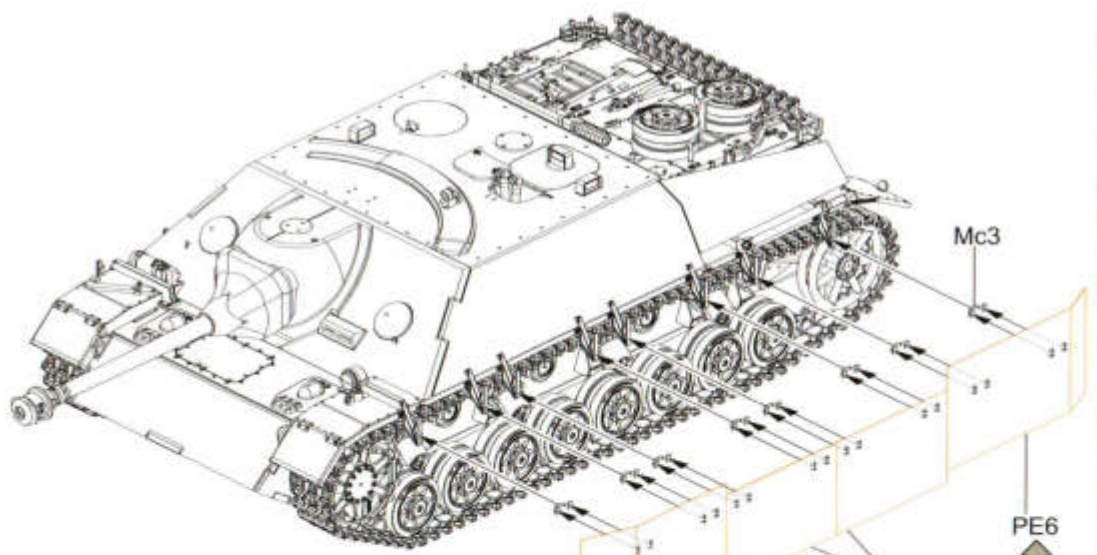

Mc3

PE6
↕
PE7

PE1
对侧相同
Both side

PE8 ↔ PE9

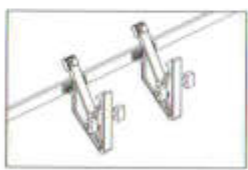

JAGDPANZER IV L/48 EARLY

PAINTING AND MARKING GUIDE

BORDER MODEL REF: BF-016 Jagdpanzer IV L/48 (early) .Pz.Div.LAH 1944.

 A.MIG-0002 Olivgrün	 A.MIG-0010 Dunkelgelb	 A.MIG-0015 RAL 8017 Schokobraun	 A.MIG-0033 Rubber & Tires
 A.MIG-0035 Dark Tracks	 A.MIG-0042 Old Rust	 A.MIG-0096 Crystal Periscope Green	

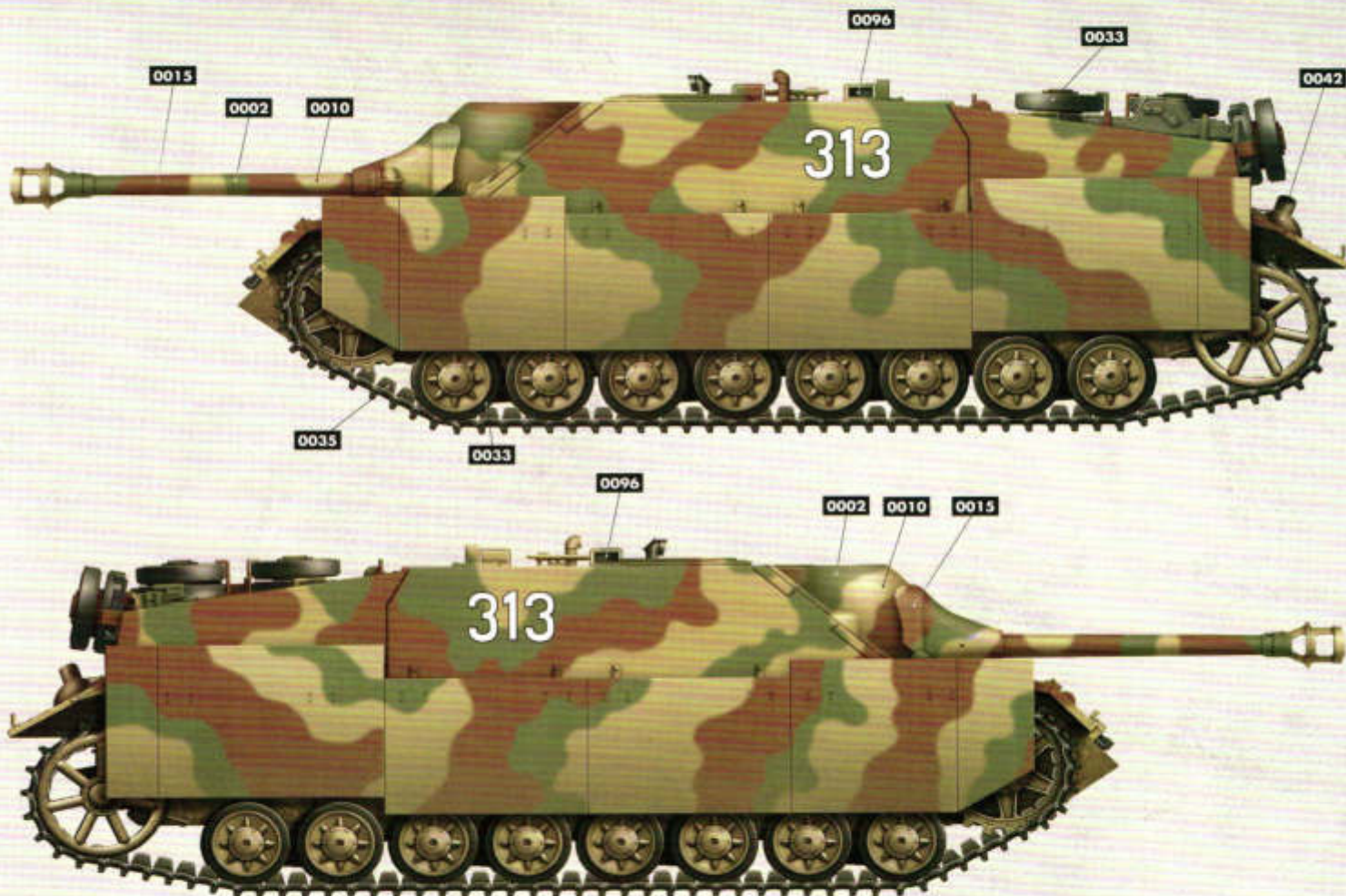

WEATHERING STEPS WITH AMMO PRODUCTS

1 GENERAL WASH A.MIG-1000 Brown Wash for German Dark Yellow	3 STREAKING A.MIG-1203 Streaking Grime	5 RUST A.MIG-1254 Streakingbrusher Rust	7 MUD A.MIG-1704 Heavy Earth	9 FUEL A.MIG-1409 Fuel Stains
2 FILTER A.MIG-1511 Brown for Dark Yellow	4 TRACKS WASH A.MIG-1002 Tracks Wash	6 DUST A.MIG-3011 Airfield Dust Pigment	8 SPLASHES A.MIG-1753 Turned Dirt	10 OIL A.MIG-1408 Fresh Engine Oil

JAGDPANZER IV L/48 EARLY

PAINTING AND MARKING GUIDE

BORDER MODEL REF: BF-016 Jagdpanzer IV L/48 (early). Unidentified Unit, Normandy 1944.

 A.MIG-0002 Olivgrön	 A.MIG-0010 Dunkelgelb	 A.MIG-0015 RAL 8017 Schokobraun	 A.MIG-0033 Rubber & Tires
 A.MIG-0035 Dark Tracks	 A.MIG-0042 Old Rust	 A.MIG-0099 Crystal Black Blue	

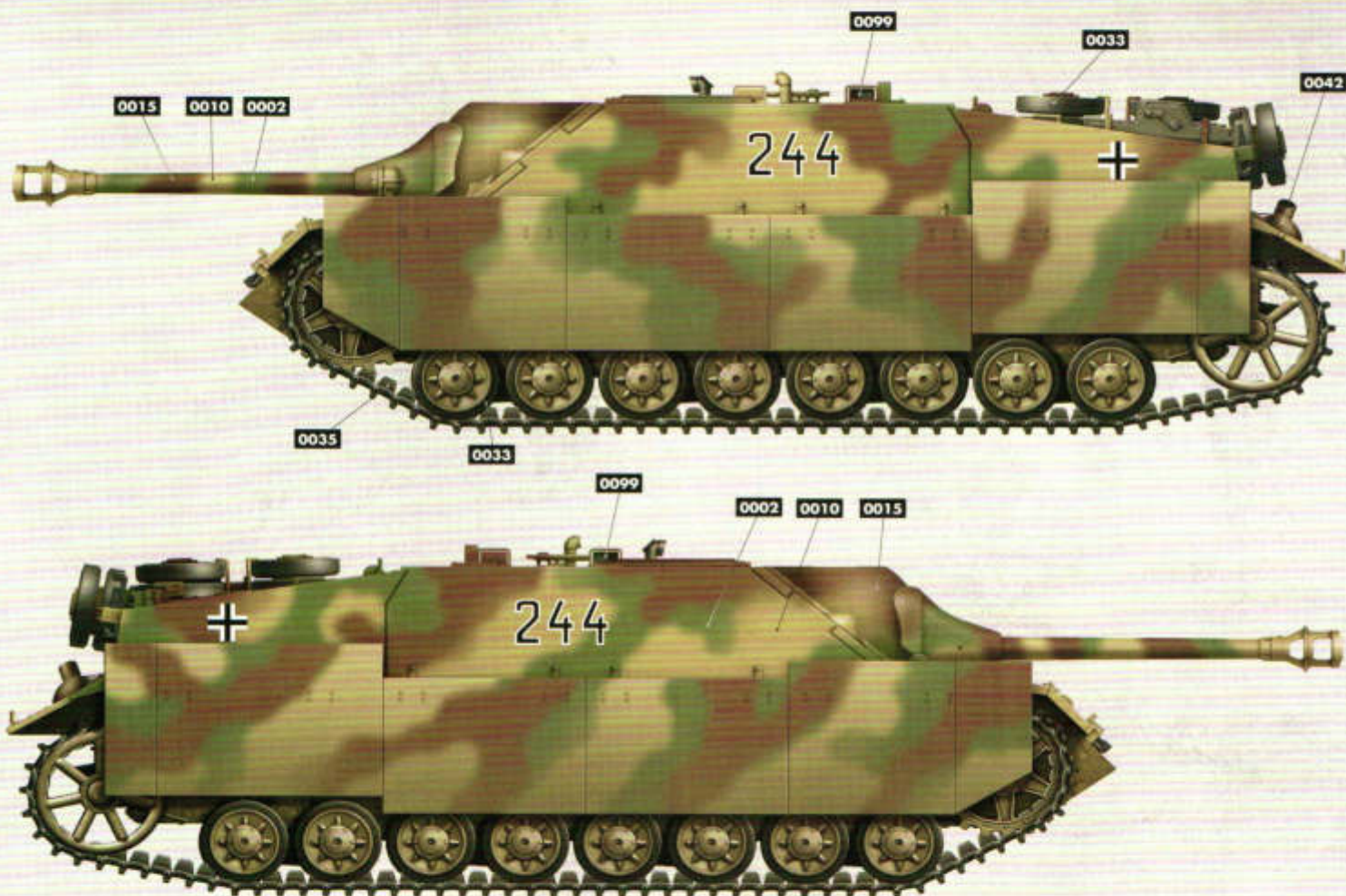







WEATHERING STEPS WITH AMMO PRODUCTS

1 GENERAL WASH A.MIG-1000 Brown Wash for German Dark Yellow	3 STREAKING A.MIG-1203 Streaking Grime	5 RUST A.MIG-1254 Streakingbrusher Rust	7 MUD A.MIG-1704 Heavy Earth	9 FUEL A.MIG-1409 Fuel Stains
2 FILTER A.MIG-1511 Brown for Dark Yellow	4 TRACKS WASH A.MIG-1002 Tracks Wash	6 DUST A.MIG-3011 Airfield Dust Pigment	8 SPLASHES A.MIG-1753 Turned Dirt	10 OIL A.MIG-1408 Fresh Engine Oil

JAGDPANZER IV L/48 EARLY

PAINTING AND MARKING GUIDE

BORDER MODEL REF: BF-016 Jagdpanzer IV L/48 (early) . Pz.Abt 228 . 116 Pz Div . Normandy 1944.

 A.MIG-0002 Olivgrün	 A.MIG-0010 Dunkelgelb	 A.MIG-0033 Rubber & Tires	 A.MIG-0035 Dark Tracks
 A.MIG-0042 Old Rust	 A.MIG-0096 Crystal Periscope Green		

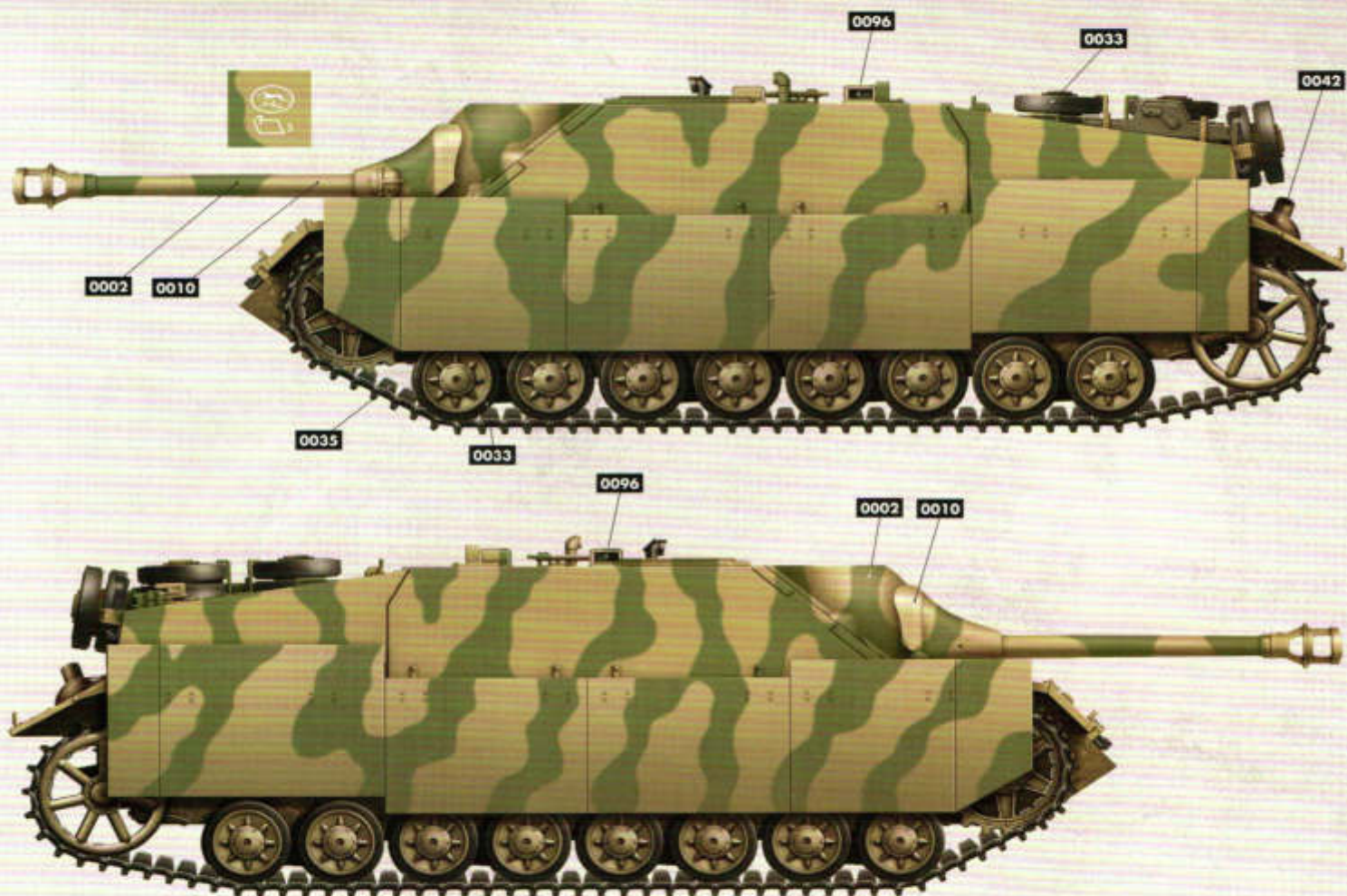

WEATHERING STEPS WITH AMMO PRODUCTS

1 GENERAL WASH A.MIG-1000 Brown Wash for German Dark Yellow	3 STREAKING A.MIG-1203 Streaking Grime	5 RUST A.MIG-1254 Streakingbrusher Rust	7 MUD A.MIG-1704 Heavy Earth	9 FUEL A.MIG-1409 Fuel Stains
2 FILTER A.MIG-1511 Brown for Dark Yellow	4 TRACKS WASH A.MIG-1002 Tracks Wash	6 DUST A.MIG-3011 Airfield Dust Pigment	8 SPLASHES A.MIG-1753 Turned Dirt	10 OIL A.MIG-1408 Fresh Engine Oil

DIY Zimmerit Tutorial

防磁装甲制作



1. Use Border #280 sanding sponge sand the plastic surface to increase the adhesion.

1. 使用边境#280海绵砂纸对塑料表面进行处理，增加附着力。



2. Mix equal amounts of Border Epoxy putty thoroughly.

2. 将等量的边境AB补土进行充分混合。

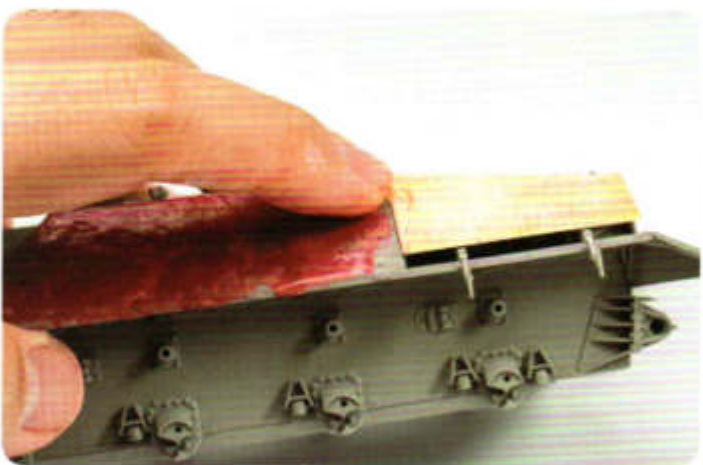

3. As the putty is soft, you can apply it to the model surface with your fingers, and then dip in water for a second touch-up to ensure the thickness of the putty is even.

3. 由于补土比较柔软，可用手指将其涂抹到模型装甲表面，然后用手指沾水进行二次修整，保证补土的厚度均匀。

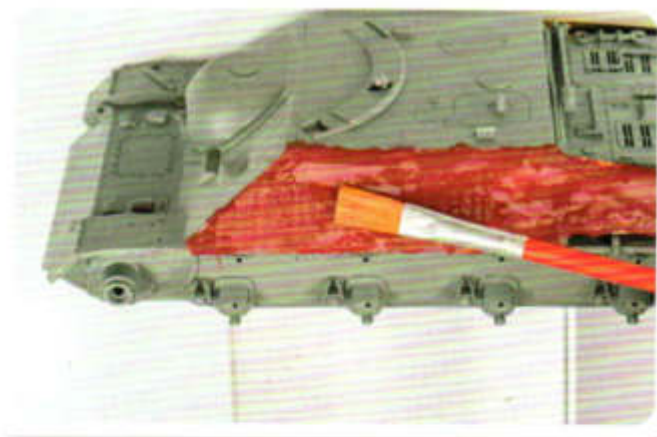

4. Before shaping the Zimmerit, you need to keep the putty and tools moist.

4. 在刮防磁前，需要让补土和刮片保持湿润。



5. Using the metal scrapers provided by the Border, scrape in a certain direction anti-magnetic texture. Be careful to control the depth of the scrapers, on the one hand, not to pressed too deep, otherwise the whole layer of putty will be peeled off; At the same time, it should not be too shallow, otherwise the texture will not be uniform.

5. 使用边境提供的金属刮片，按一定的方向刮出防磁纹理。注意控制刮片的深度，一方面不能压得太深，否则会令补土层整片剥离；同时，也不能太浅，否则纹理会不够均匀。

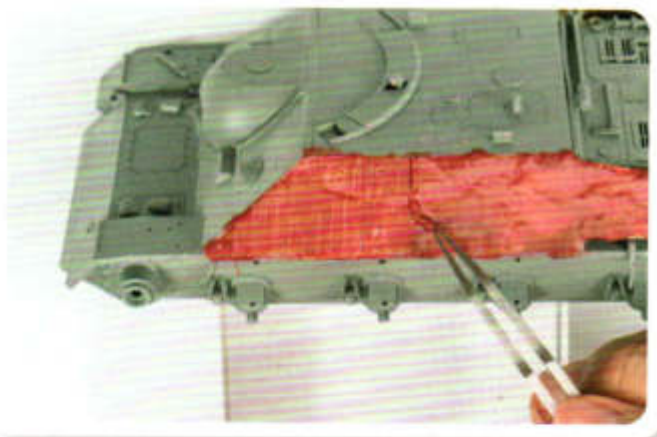

6. You can use tweezers to remove excess putty, otherwise it will increase the resistance during operation and cause the putty to break.

6. 可以用镊子去除多余的补土，否则会增大操作时的阻力，导致补土破碎。



7. Use a knife to trim away any overflowing putty at the edges before the putty hardens.

7. 趁AB补土硬化前，用笔刀修去边缘溢出的补土。



8. Real Zimmerit coating will cover off part of the weld lines, screws and other details, you can cut off some of them that get in the way beforehand.

8. 真实的防磁涂层会覆盖掉一部分战车的焊线、螺钉等细节，可以事先把一些碍事的凸起物切掉。



9. A little moisture can slow down the hardening of the epoxy putty.

9. 一定的水分可以延缓AB补土的硬化速度。



10. The style of Zimmerit texture needs to refer to the actual photos, pay attention to ensure that the scrapers move in the horizontal direction, otherwise the texture will show messy.

10. 防磁纹理的样式需要参考实车照片，注意保证刮片在水平方向移动，否则纹理会显得凌乱。



11. Zimmerit finished effect.

11. 防磁制作完成的效果。



12. Next, go ahead and make the tarp using epoxy putty. Add some personalized details to your model. The talc will reduce the stickiness of the putty and make it easier to shaping.

12. 接下来继续使用AB补土制作防雨布，给你的模型增加一些个性化的细节。爽身粉可以降低补土的黏性，方便制作。

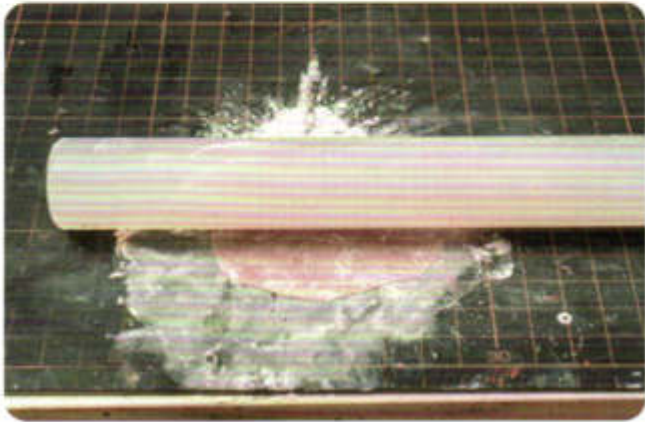

13. Use a rolling pin to roll out the putty into pieces, you need to keep adding talc during the process to prevent sticking.

13. 用擀面杖将AB补土擀成片，过程中需要不停的加爽身粉，防止粘连。

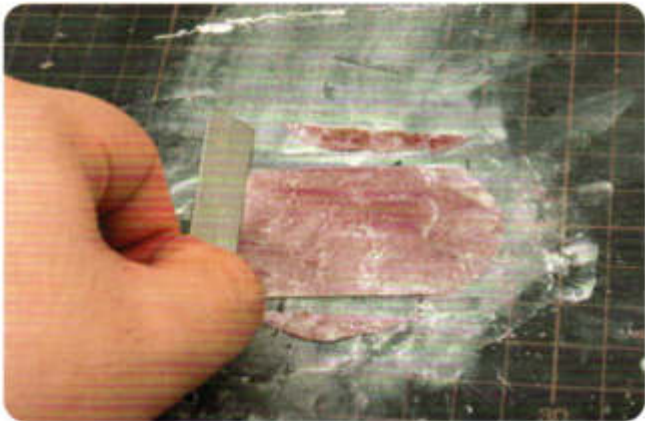

14. Use a blade to cut the putty piece into a rectangle.

14. 用刀片将补土片裁成矩形。



15. Carefully roll up the putty with tweezers.

15. 用镊子小心的把补土片卷起。

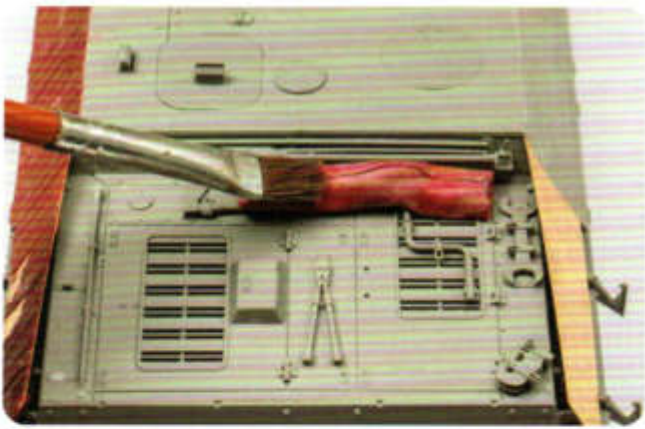

16. Use a moist brush to shape the putty rolls, the force should not be too strong, otherwise it will damage the details.

16. 用湿润的笔刷对补土卷进行塑形，力度不宜过大，否则会损伤细节。

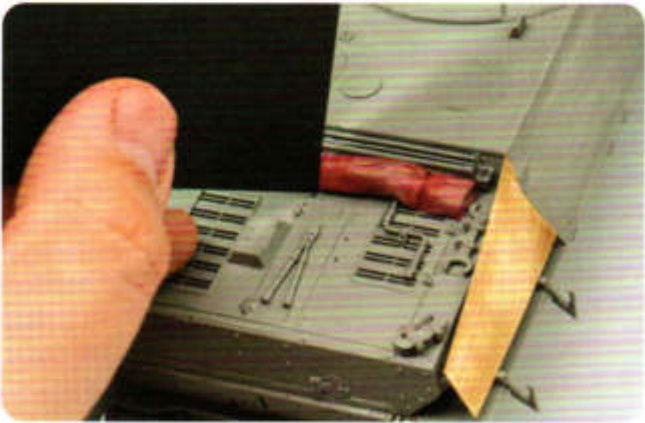

17. Using card to press out two indentations.

17. 使用卡纸，压出两道凹痕。

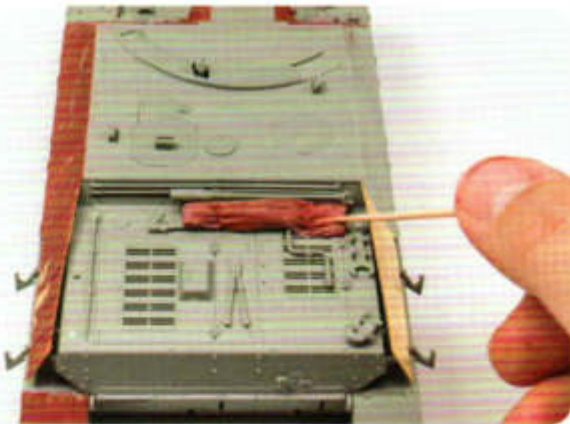

18. Sharp toothpicks are suitable for making fabric folds.

18. 尖锐的牙签适合制作布料的折痕。

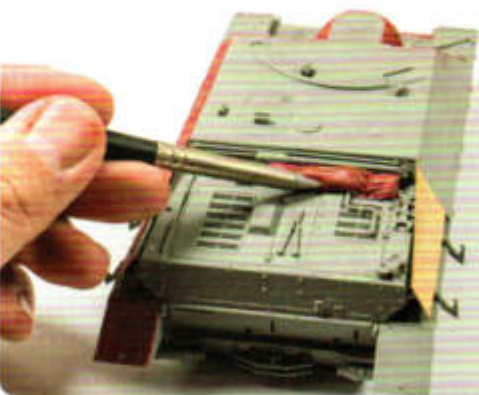

19. A soft rubber pen is suitable for softer folds.

19. 柔软的橡胶笔则适合制作较为柔和的褶皱。



20. Use a curved knife to cut and deepen the fabric edge detail.

20. 使用弧形笔刀切割，加深布料边缘细节。



21. Cut out some putty strips with a width of about 0.8 mm.

21. 切出一些宽度约为0.8mm的AB补土条。



22. Use a moist toothpick to press the strip into the previous groove to show the trapped tie detail.

22. 用湿润的牙签将补土条压入之前的凹槽，表现困扎带细节。

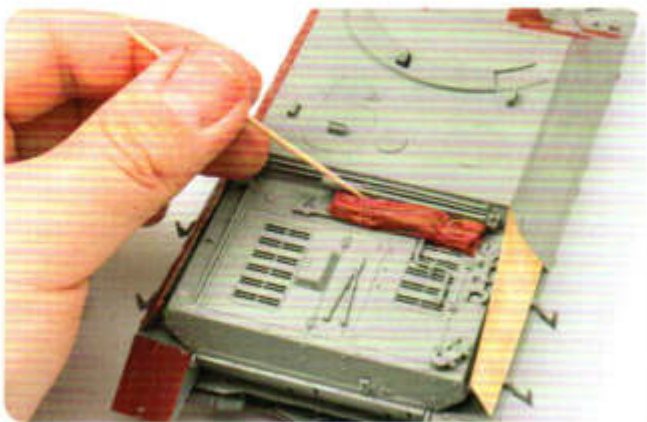

23. Patiently make corrections to the form of the trapped tie.

23. 耐心对带子形态进行修正，表现出困扎的形态。

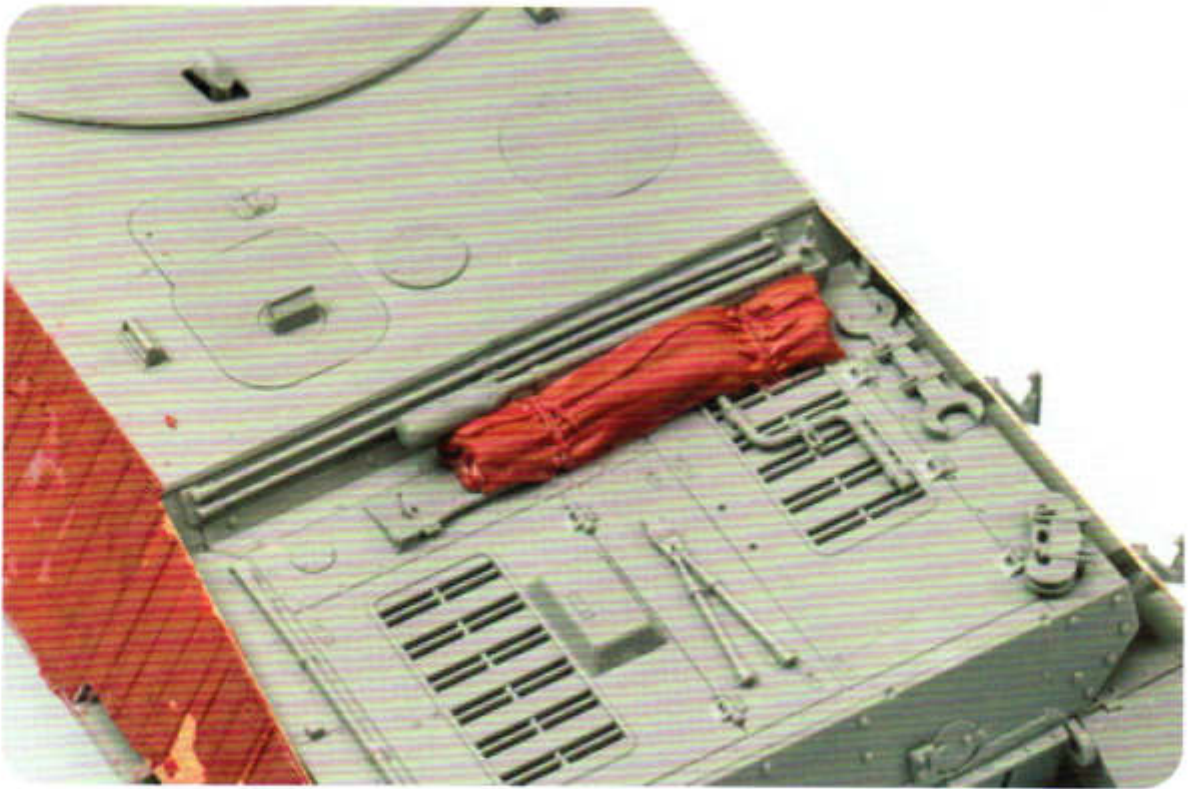

24. Finished !
24. 制作完成 !

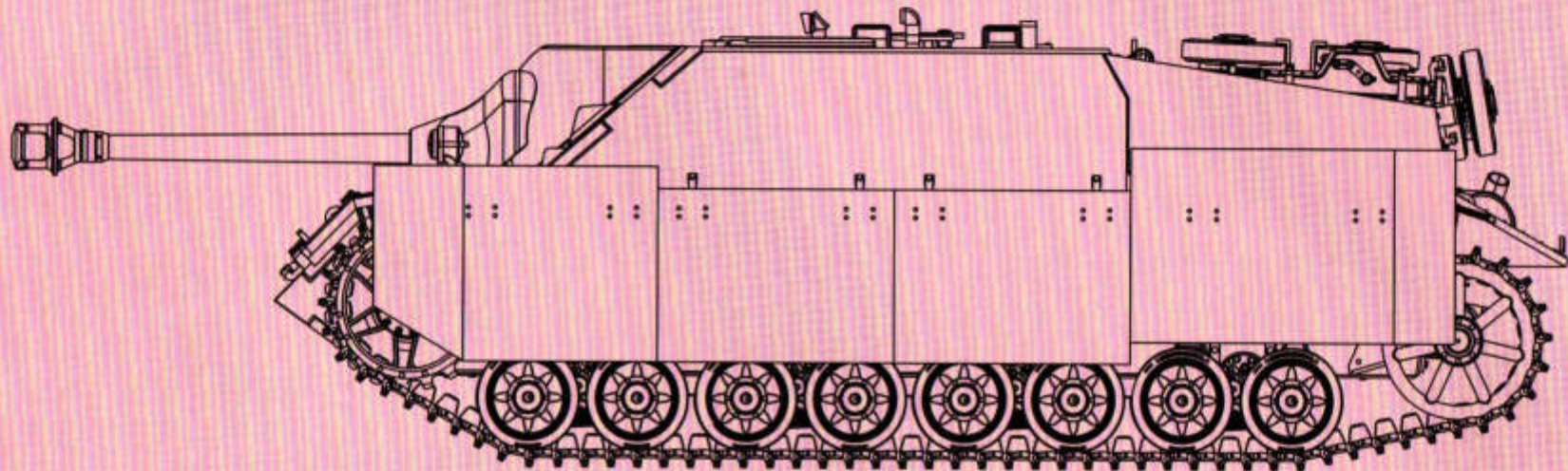

WWW.BORDERMODEL.COM