

KPM0088

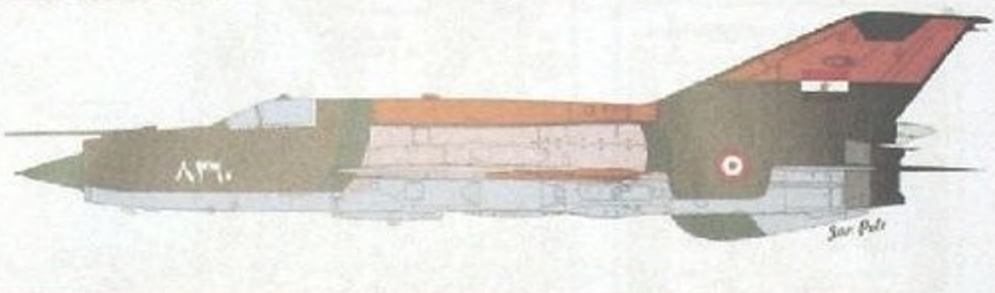

MIG - 21MF V ZEMÍCH TŘETÍHO SVĚTA THIRD WORLD USERS

Mikojan-Gurjevič MiG-21 (v kódu NATO "Fishbed") je sovětská nadzvuková víceúčelová stíhačka. Byla používána letectvy více než 30 zemí. Bylo jich vyrobeno přes 10 000 ks, což z ní činí nejvíce a nejdéle vyráběný nadzvukový letoun. Zúčastnila se mnoha ozbrojených konfliktů. Model MiG-21MF (Fishbed-J), byla verze s novým motorem R-13-300 a radarem R-22 Safir 21. Množství neseného paliva bylo omezeno, ale mohl nést přidavné nádrže, které prodloužily dolet. Výzbroj se skládala z integrovaného kanónu GS-23L a různých typů bomb, neřízených a řízených raket a raketových bloků, které byly převáženy na čtyřech pylonech po křídly. MiG-21MF se vyráběl v letech 1970–1974 hlavně k exportu v závodě v Moskvě a v roce 1975 závodě v Gorkém. Verze MiG-21MF sloužila ve velkých počtech i v Československu a byla sériově vyráběna v Indii firmou HAL.

TECHNICKÁ DATA: / TECHNICAL DATA:

Délka/Length:	15,76 m
Rozpětí/Wing span:	7,15 m
Výška/Height:	4,1 m
Nosná plocha/Wing area:	23 m ²
Hmotnost prázdná/Empty weight:	5 200 kg
Vzletová hmotnost/Take-off weight:	10 400 kg
Motor/Powerplant:	Tumanskij R-13-300 64,7 kN
Max. rychlost/Max. speed:	2229 km/h
Dolet/Range:	1160 km
Dostup/Service ceiling:	17 500 m
Výzbroj/Armament:	2x 23 mm kanón/gun GS-23

POUŽITÉ PODKLADY: / REFERENCES USED:

MiG-21, M. Ira, JAKAB
MiG-21MF in detail, kolektiv autorů, WWP
MiG-21, V. Trendafilovski, WARPAINT
21st TAC Caslav, P. Soukup, WWP
personal files/osobní sbírky

The Mikoyan-Gurevich MiG-21 (NATO reporting name Fishbed) is a supersonic jet fighter aircraft, designed by the Mikoyan-Gurevich Design Bureau in the Soviet Union. It was popularly nicknamed "Balalaika".

MiG-21MF (NATO "Fishbed-J") is an export version of the MiG-21SM, with RP-22 radar and R13-300 turbojet. The choice of weapons loads was increased with the addition of the R-60 (NATO: AA-8 "Aphid") and later the R-60M IR-seeking AAM. These were also licence-built in India by HAL as the Type 88.

The MiG-21 was exported widely and continues to be used. The aircraft's simple controls, weapons, and avionics were typical of Soviet-era military designs. The use of a tail with the delta wing aids stability, enhancing safety for lower-skilled pilots; this in turn enhanced its marketability to developing countries with limited training programs and restricted pilot pools.

REALIZAČNÍ TÝM: / REALISATION TEAM:

Koordinace výroby:	Petr Muzikant
Production coordination:	Radek Vávrova
Předlohový model:	Zdeněk Macháček
Master model:	
Titulní kresba:	
Box art:	
Návod:	Jan Polc JarďaŠ
Instruction leaflet:	
Grafika a návrh obtisků:	Jan Polc
Graphic design, decals:	
Tisk obtisků:	Radim Fronc
Decal printer:	
Konzultanti:	Slavomír Goldemund
Consultants:	Miroslav Balous Jaroslav Dobíš Václav Šorel Jaroslav Veleč Michal Ovcáček Petr Šafra

Rádi bychom poděkovali Michalovi Ovcáčkovi, Petru Šafrovi a Milanu Simrovi za neocenitelnou pomoc.
We would like to express our thanks to Michal Ovcáček, Petr Šafra and Milan Simr for their valuable help.

Plastikové díly - Plastic parts

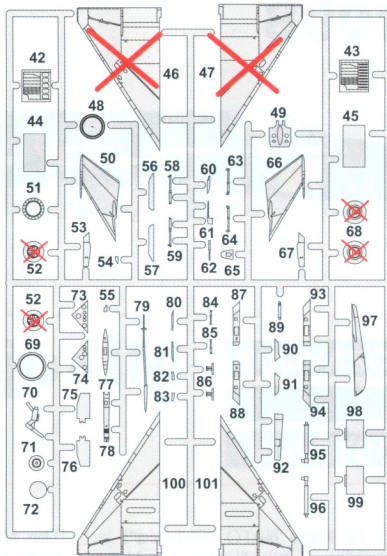
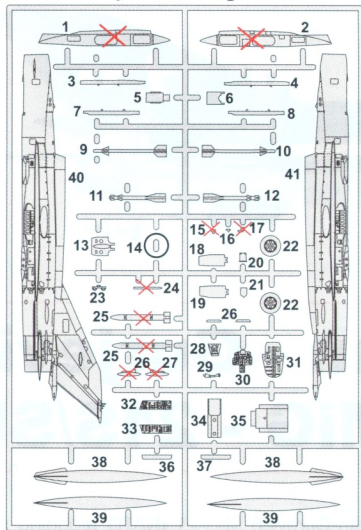

Průhledné díly/
Clear parts

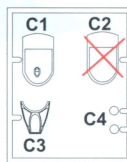

Stavební postup - Assembly instructions

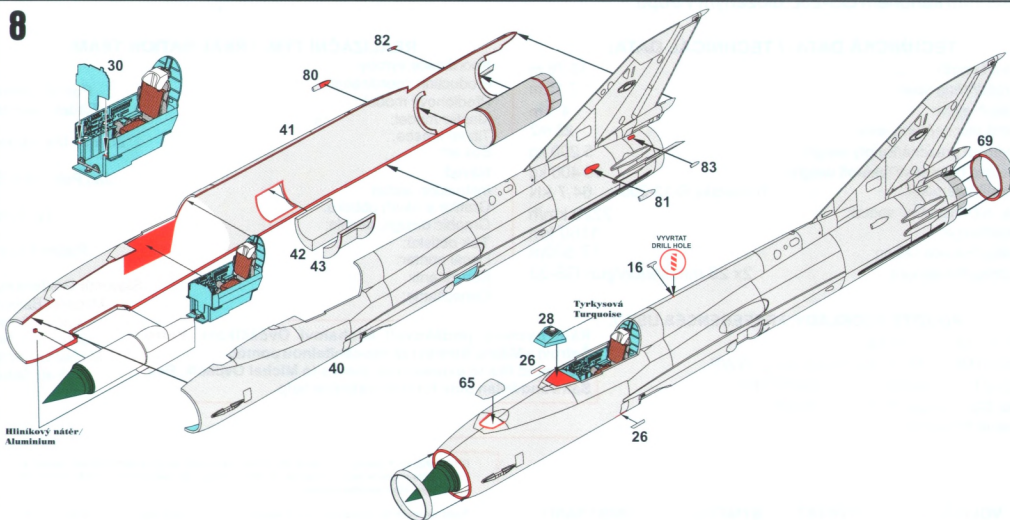
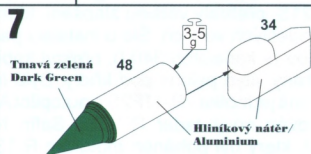
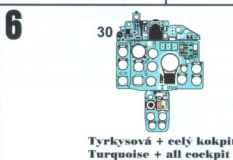
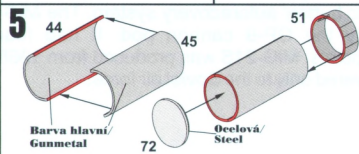
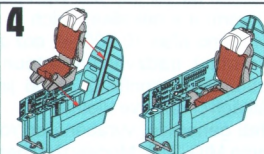
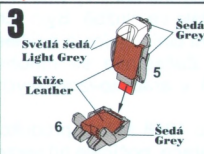
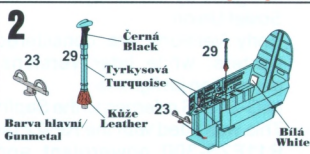
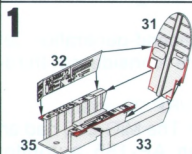

9

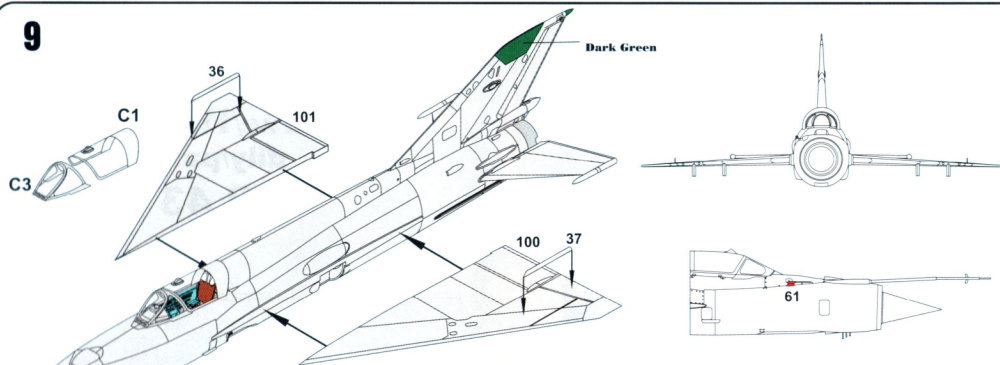

10

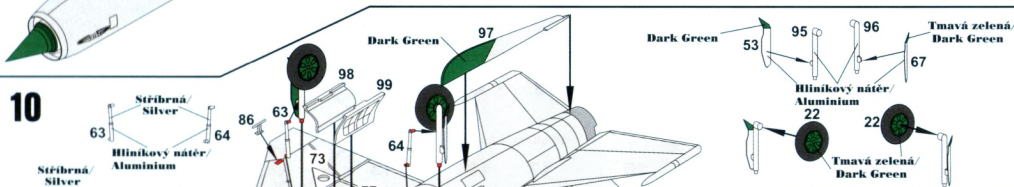

11

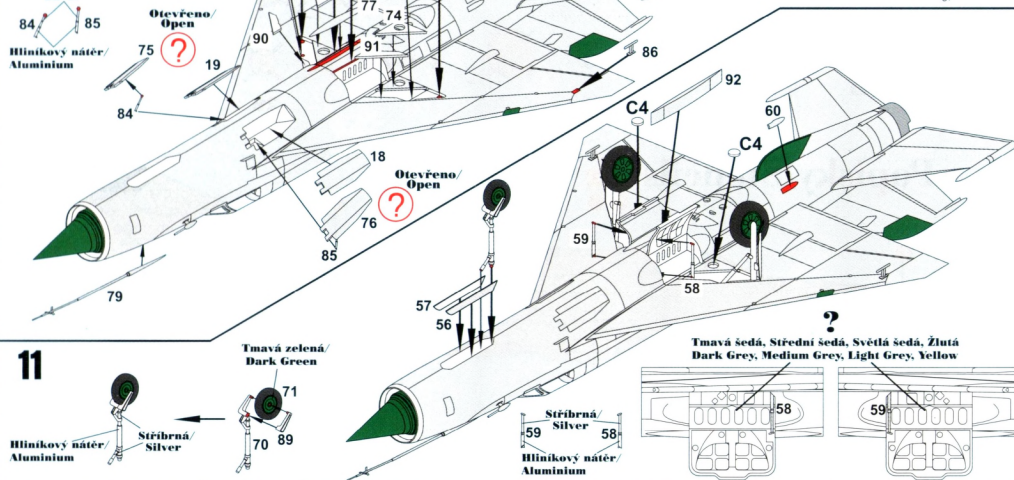

12

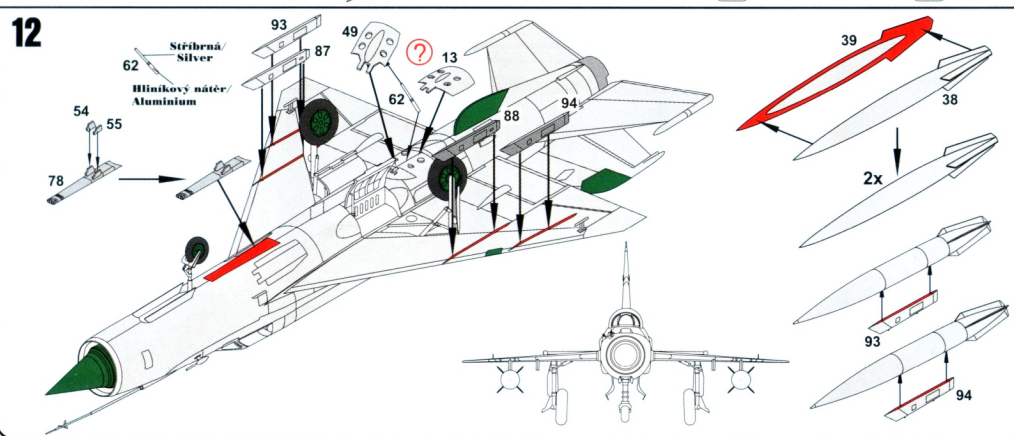

Možnosti výzbroje/Armament diagram



Nádrže/Fuel tanks
díly/parts
42 43

S-24



29

29



Adaptéry/Adapters

R-3S



19

3

4

20



Adaptéry/Adapters

R-60



10

17

18

13



S-24
R-3S

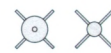

29

19 + 3



4 + 20



29

Popisky/Stencils

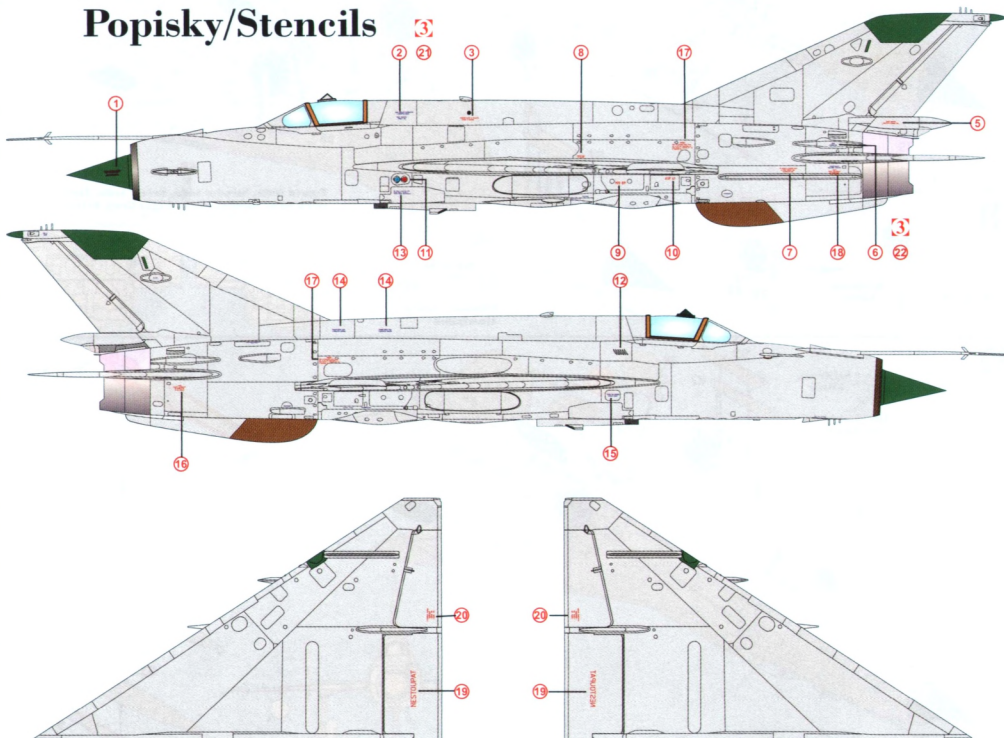

1

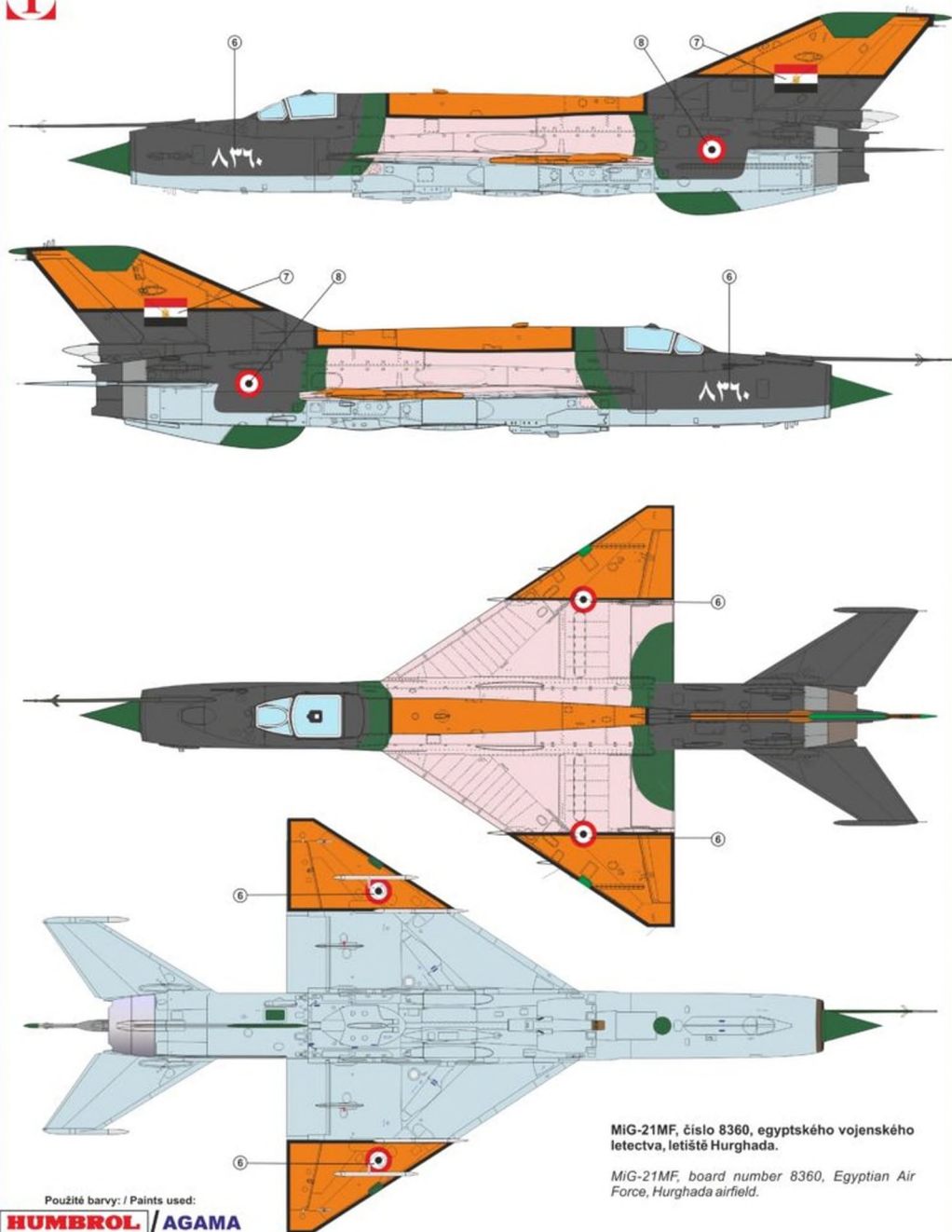

MIG-21MF, číslo 8360, egyptského vojenského letectva, letiště Hurghada.

MIG-21MF, board number 8360, Egyptian Air Force, Hurghada airfield.

Použité barvy: / Paints used:

HUMBROL / AGAMA

61 25	18 16	116 A7	98 F6	87 R23	33 07	53 57	171 47	2 19
Písková Sand	Oranžová Orange	Tmavá zelená Dark Green	Hnědá Brown	Světlá modrá Light Blue	Černá Black	Žihaná ocel Burnt Iron	Tmavá ocel Dark Steel	Střední zelená Mid Green

2

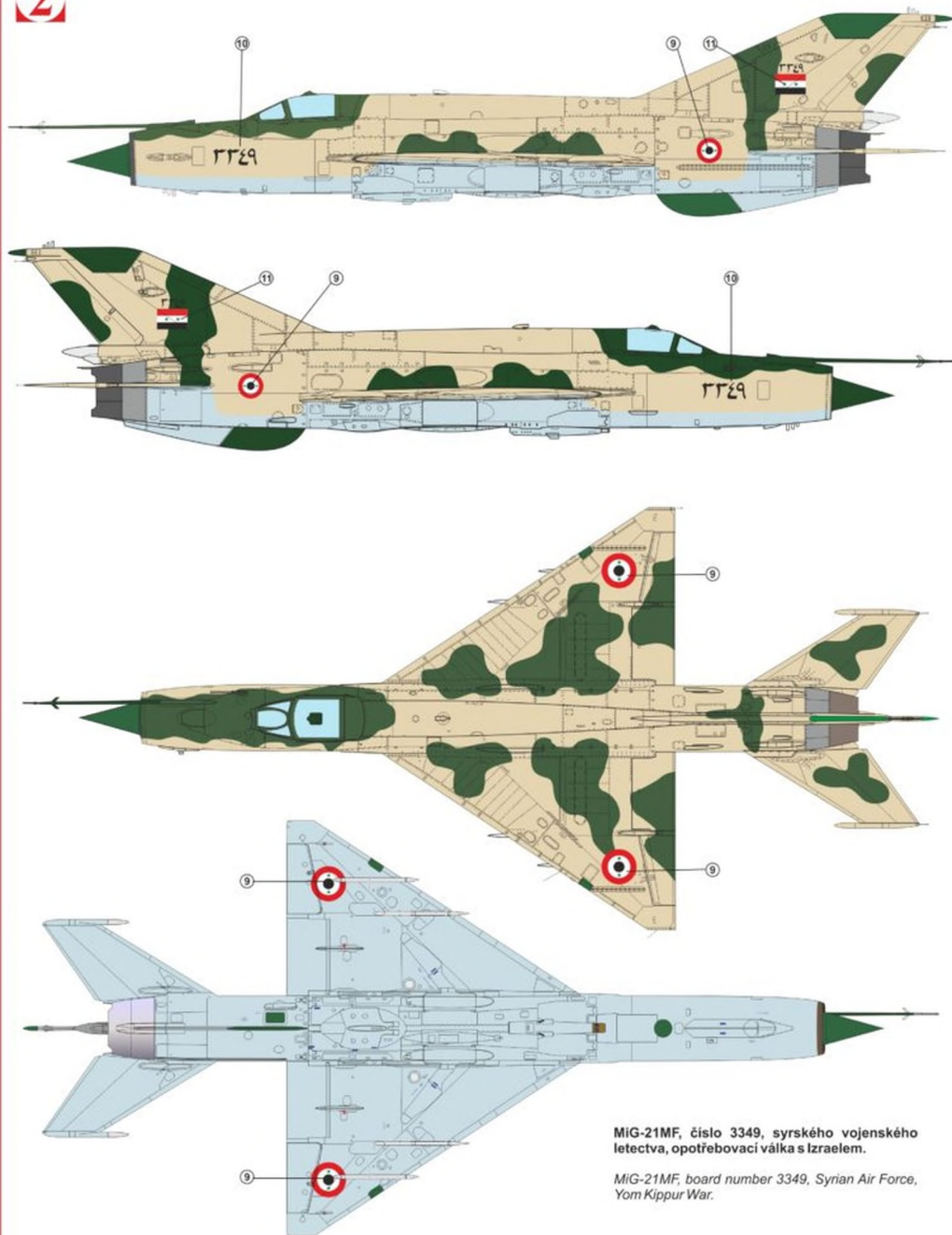

MIG-21MF, číslo 3349, syrského vojenského letectva, opoťebovací válka s Izraelem.

MIG-21MF, board number 3349, Syrian Air Force, Yom Kippur War.

Použité barvy: / Paints used:

HUMBROL / **AGAMA**

94 C32

Písková
Sand

30 R9

Tmavá zelená
Dark Green

65 N5

Světlá modrá
Light Blue

53 57

Žihaná ocel
Burnt Iron

171 47

Tmavá ocel
Dark Steel

2 19

Střední zelená
Mid Green

3

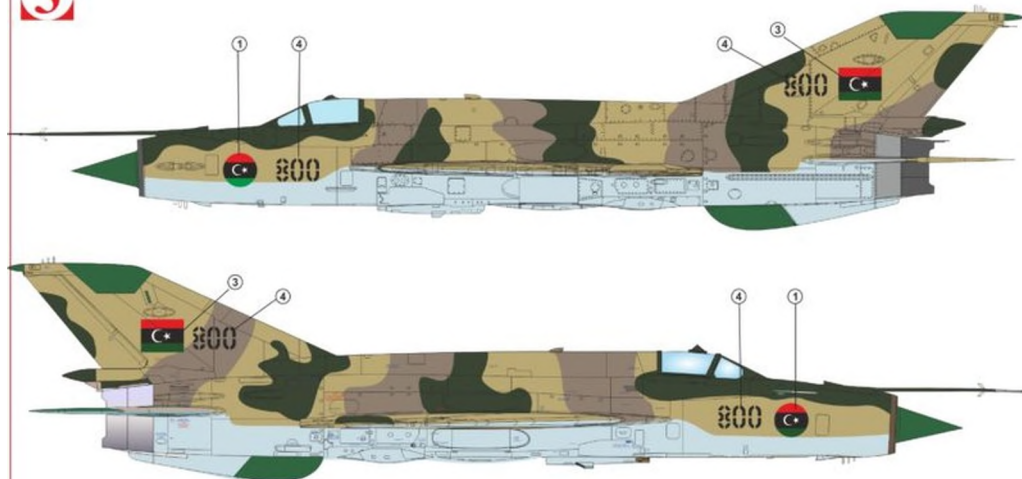

Tento letoun létal v určitém období s původními lybijskými znaky na nosných plochách. Pro tuto alternativu použijte obtiskč. 5.

This aircraft had original lybian roundels for certain period of time. For this option use the decal No. 5.

?

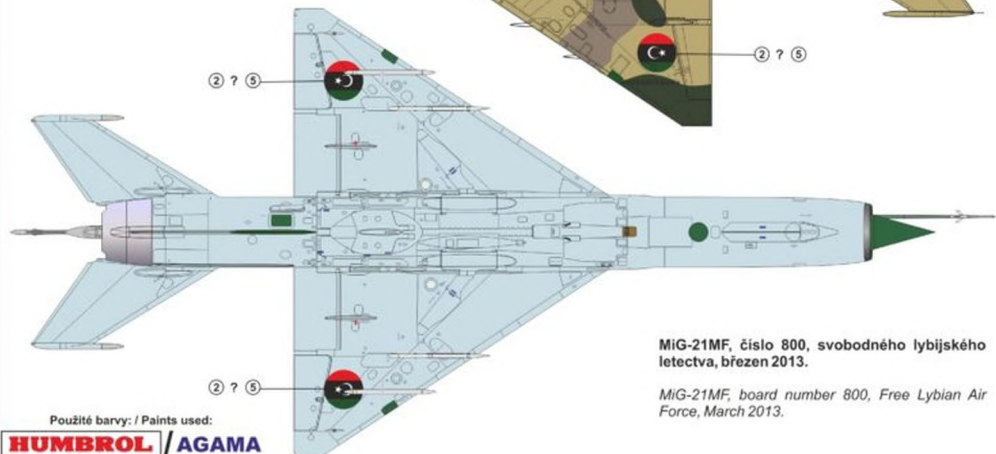
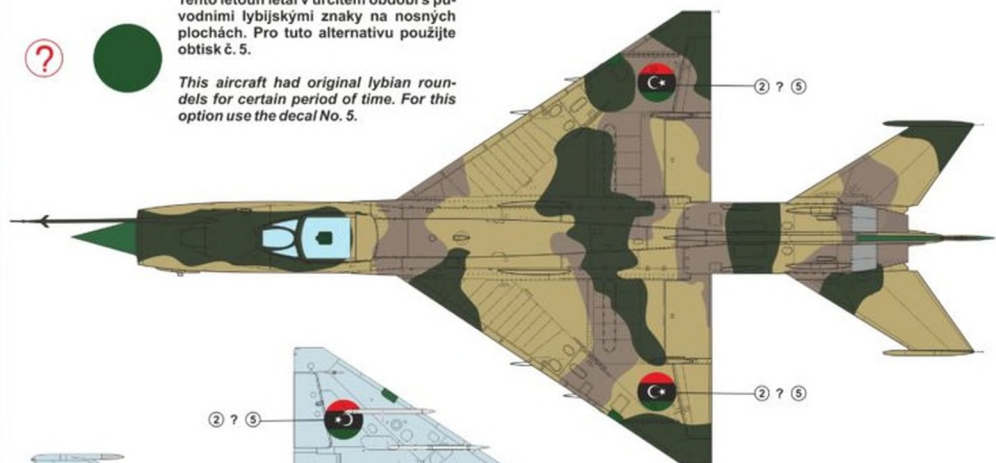

MIG-21MF, číslo 800, svobodného lybijského letectva, březen 2013.

MIG-21MF, board number 800, Free Lybian Air Force, March 2013.

Použité barvy: / Paints used:

HUMBROL / AGAMA

93 B27

Písková
Sand

119 120

Písková tmavá
Dark Sand

30 R9

Tmavá zelená
Dark Green

87 R23

Světlá modrá
Light Blue

53 57

Žíhaná ocel
Burnt Iron

171 47

Tmavá ocel
Dark Steel

2 19

Střední zelená
Mid Green

4

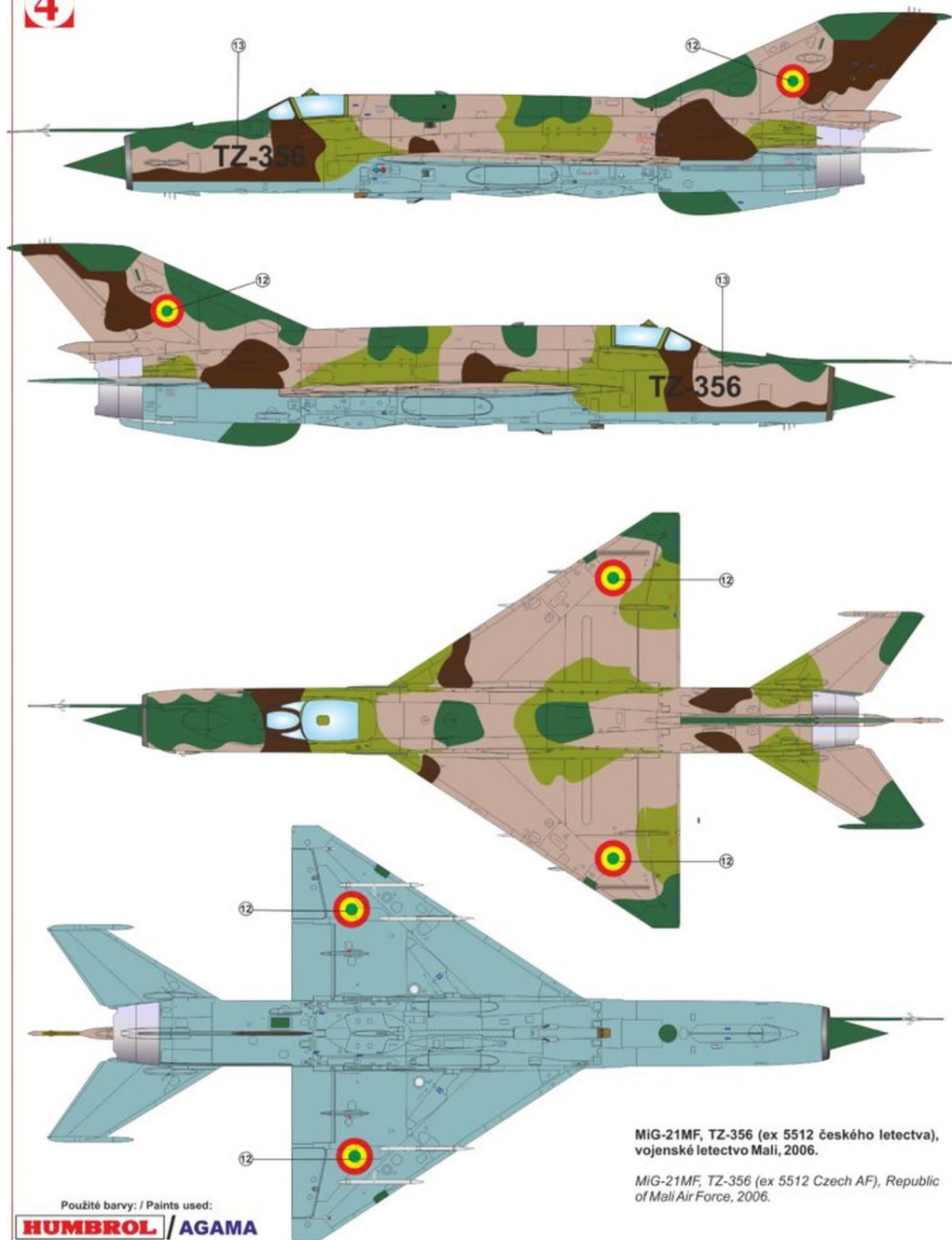

MIG-21MF, TZ-356 (ex 5512 českého letectva), vojenské letectvo Mali, 2006.

MIG-21MF, TZ-356 (ex 5512 Czech AF), Republic of Mali Air Force, 2006.

Použité barvy: / Paints used:

HUMBROL / AGAMA

121 Iz3

Písková
Sand

120 Iz2

Světlá zelená
Light Green

117 A8

Tmavá zelená
Dark Green

185 A38

Hnědá
Brown

65 N5

Světlá modrá
Light Blue

53 57

Žíhaná ocel
Burnt Iron

171 47

Tmavá ocel
Dark Steel

2 19

Střední zelená
Mid Green