

PLASTIC PARTS

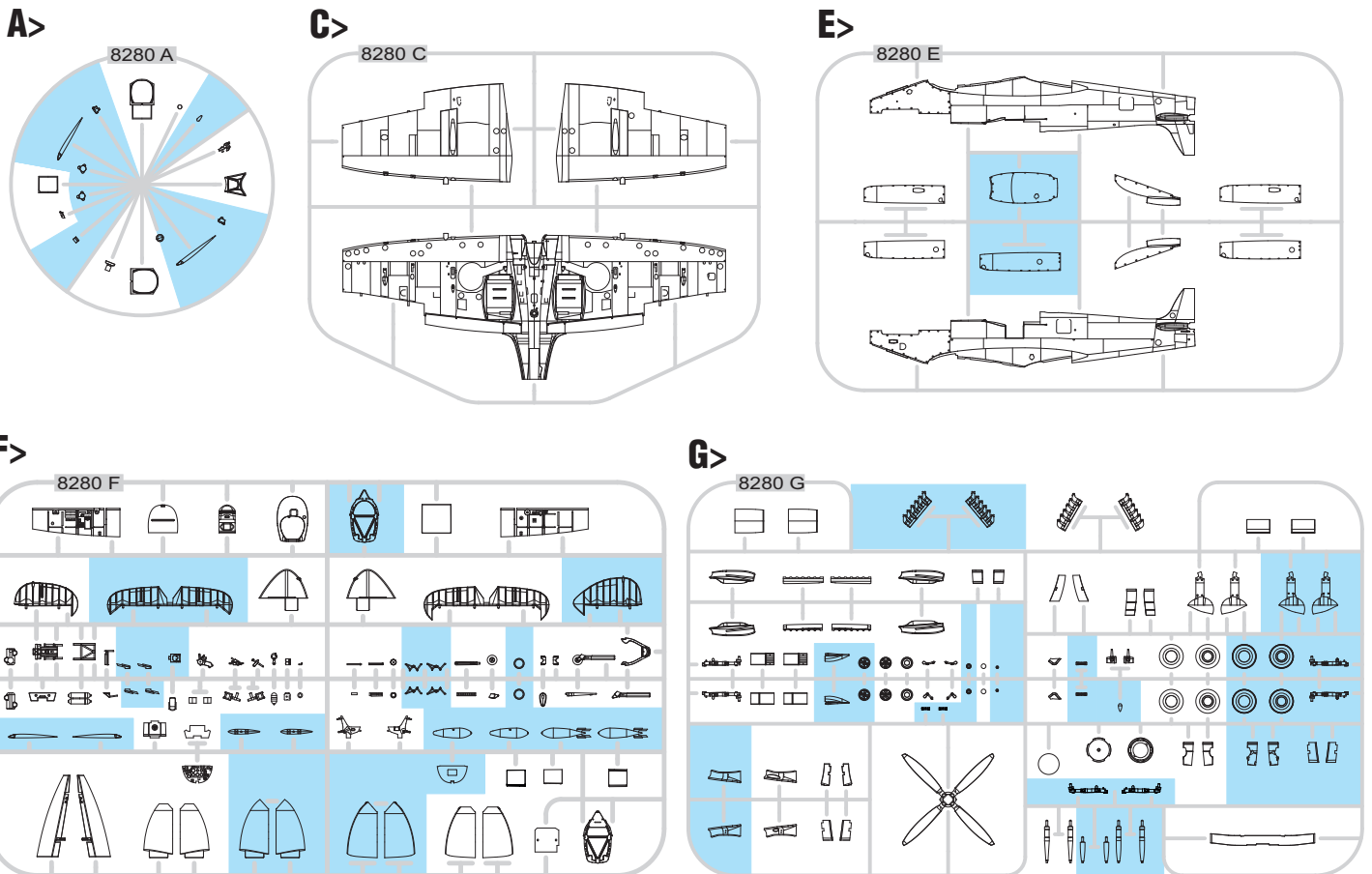

GUNZE	MISSION MODELS	
H4	C4	MMP-007 YELLOW
H11	C62	MMP-001 FLAT WHITE
H12	C33	MMP-047 FLAT BLACK
H13	C3	MMP-003 FLAT RED
H33	C81	RUSSET
H51	C11	MMP-063 LIGHT GULL GRAY
H74	C368	MMP-080 SKY

GUNZE	MISSION MODELS	
H77	C137	MMP-047 TIRE BLACK
H90	C47	CLEAR RED
H94	C138	CLEAR GREEN
H330	C361	MMP-077 DARK GREEN
H335	C363	MMP-094 MEDIUM SEAGRAY
	C362	MMP-093 OCEAN GRAY
	C364	MMP-079 AIRCRAFT GRAY-GREEN

MC/METAL	METALLICS	
MC214	MMM-001	DARK IRON
MC218	MMM-003	ALUMINIUM
MC/METAL	METALLICS	
SM01	MMC-001	SUPER CHROME

ATTENTION * UPOZORNĚNÍ * ACHTUNG * ATTENTION

- (GB)** Carefully read instruction sheet before assembling. When you use glue or paint, do not use near open flame and use in well ventilated room. Keep out of reach of small children. Children must not be allowed to suck any part, or pull vinyl bag over the head.
- (CZ)** Před započatím stavby si pečlivě prostudujte stavební návod. Při používání barev a lepidel pracujte v dobře větrané místnosti. Lepidla ani barvy nepoužívejte v blízkosti otevřeného ohně. Model není určen malým dětem, mohlo by dojít k požití drobných dílů.
- (D)** Vor dem Zusammenbau die Bauanleitung gut durchlesen. Kleber und Farben nicht in der Nähe von offenem Feuer verwenden und für eine ausreichende Belüftung sorgen. Den Bausatz von kleinen Kindern fernhalten. Vermeiden Sie, dass Kinder Bauteile in den Mund nehmen oder sich Plastiktüten über den Kopf ziehen.
- (F)** Lire soigneusement la fiche d'instructions avant d'assembler. Ne pas utiliser de colle ou de peinture à proximité d'une flamme nue, et aérer la pièce de temps en temps. Garder hors de portée des enfants en bas âge. Ne pas laisser les enfants mettre en bouche ou sucer les pièces, ou passer un sachet vinyl sur la tête.

INSTRUCTION SIGNS * INSTR. SYMBOLY * INSTRUKTION SINNBILDEN * SYMBOLES



OPTIONAL
FACULTATIF
NACH BELIEBEN
VOLBA



BEND
PLIER SIL VOUS PLAÏT
BITTE BIEGEN
OHNOUT



OPEN HOLE
FAIRE UN TROU
OFFNEN
VYVRTAT OTVOR



SYMETRICAL ASSEMBLY
MONTAGE SYMÉTRIQUE
SYMMETRISCHE AUFBAU
SYMETRICKÁ MONTÁŽ



REVERSE SIDE
OTOČIT



REMOVE
RETIRER
ENTFERNEN
ODŘÍZNOUT

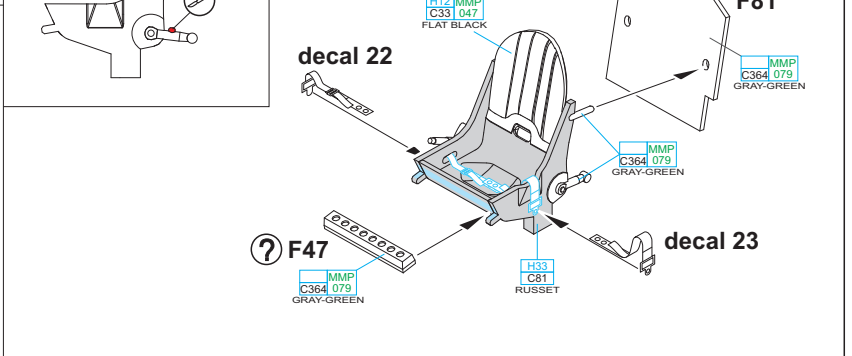
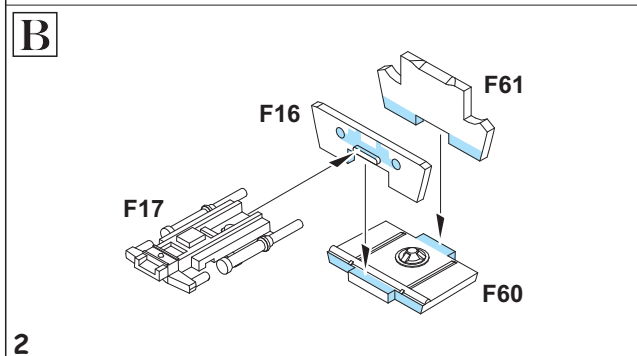
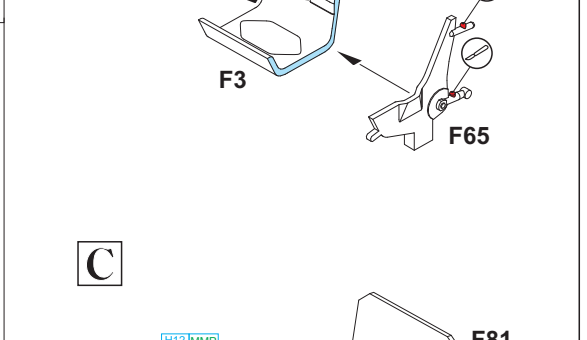
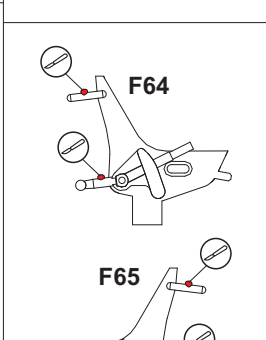
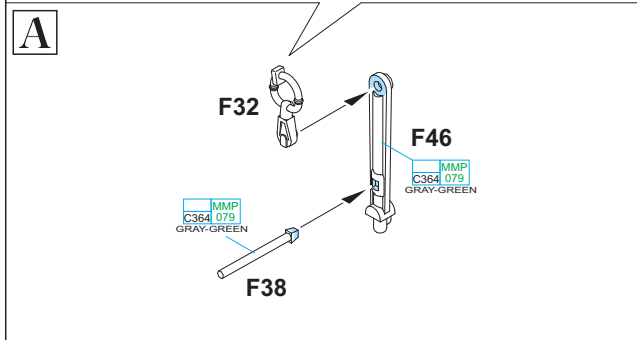
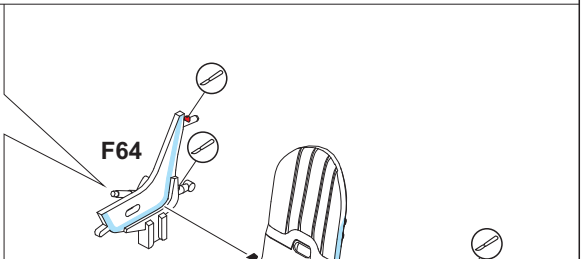
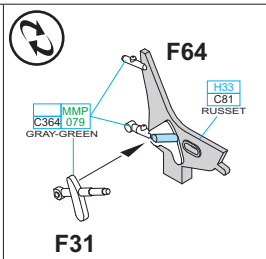
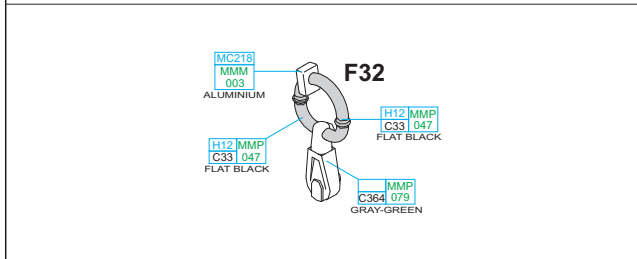
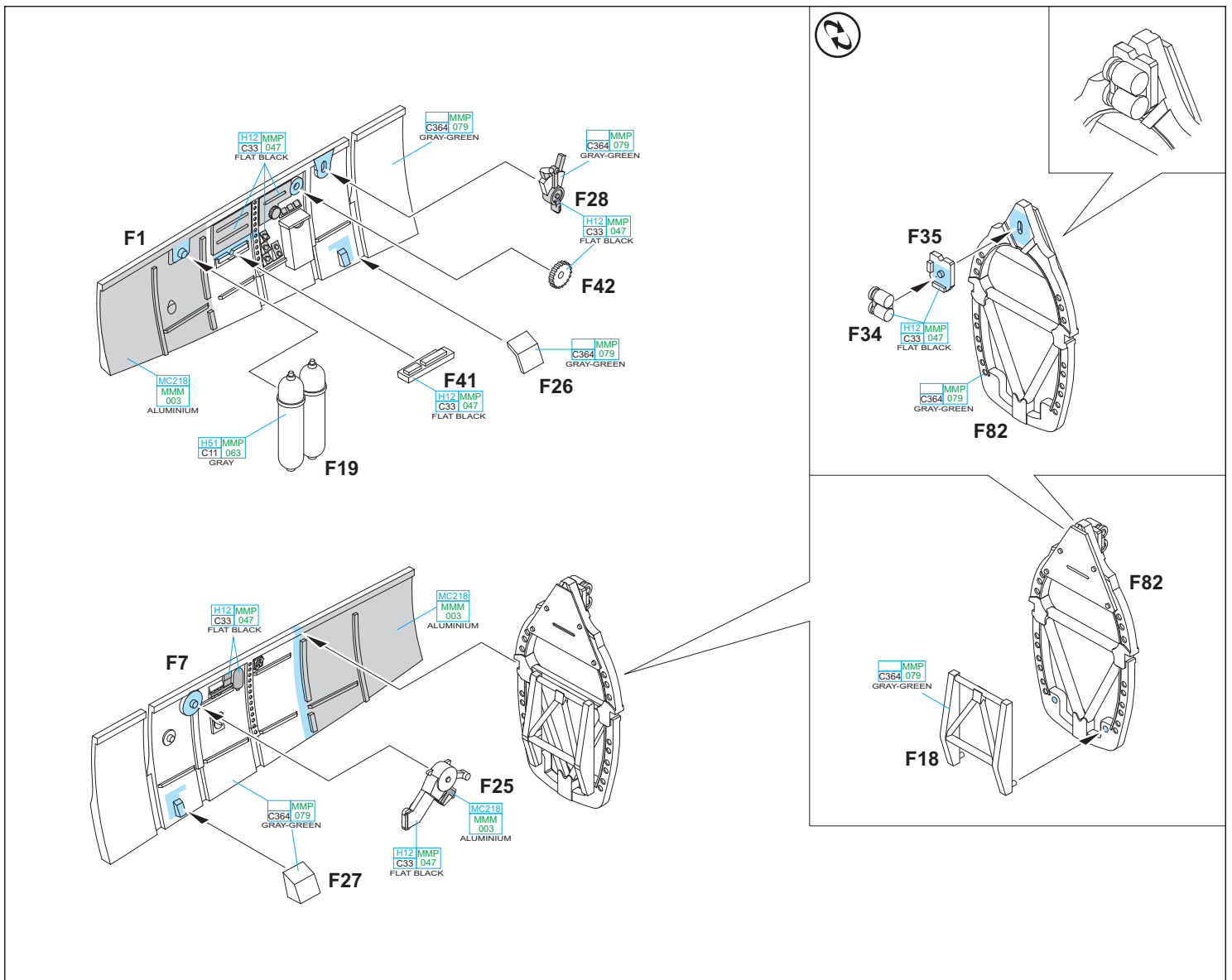

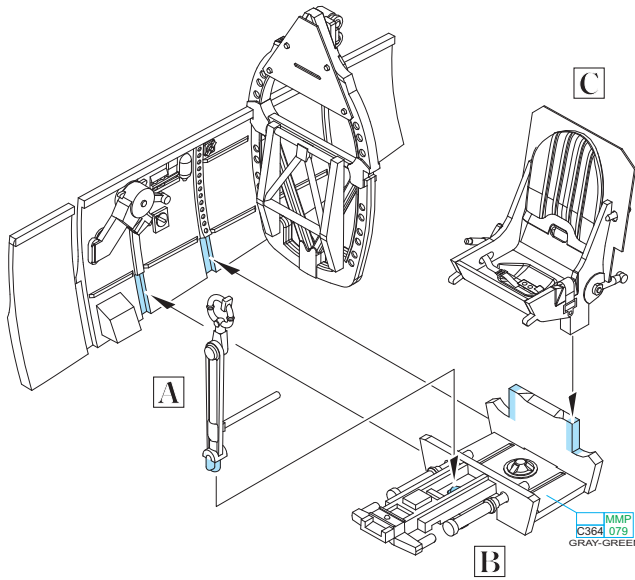

decal 24

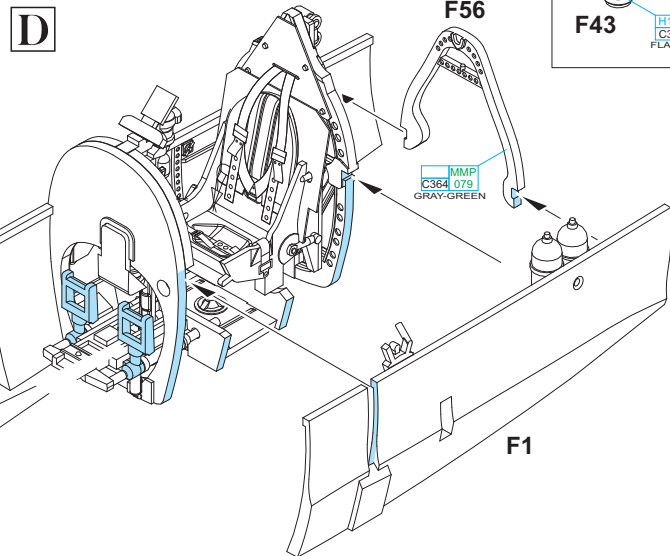
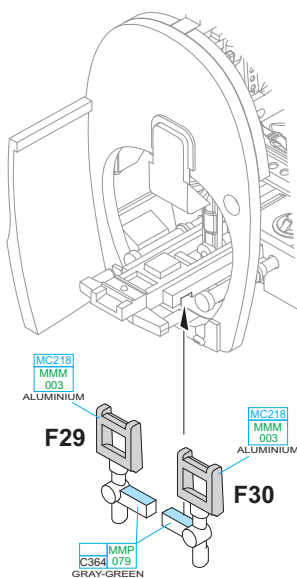
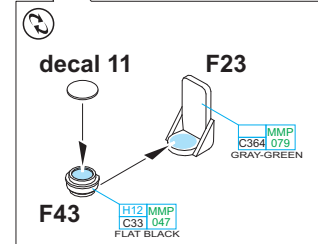
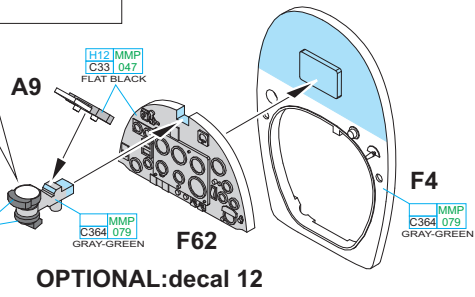
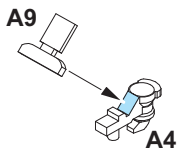
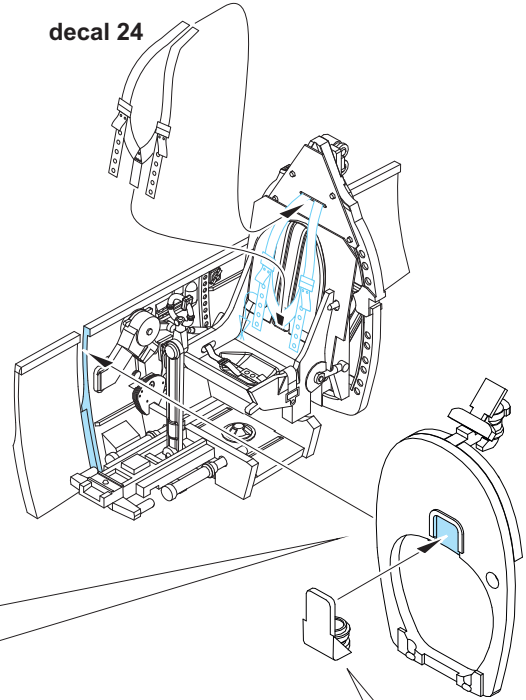

FOR CLOSED CANOPY ONLY

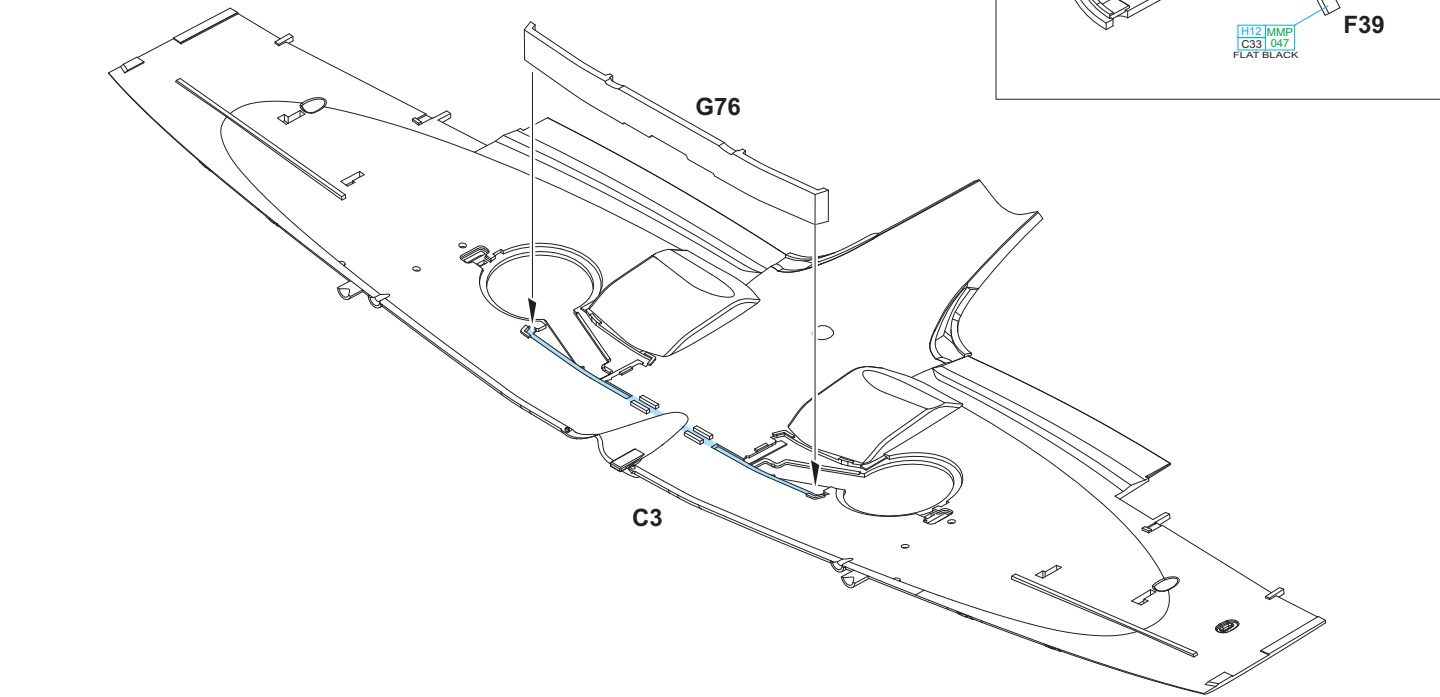
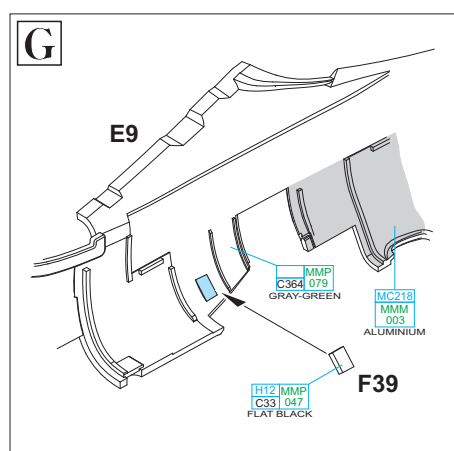
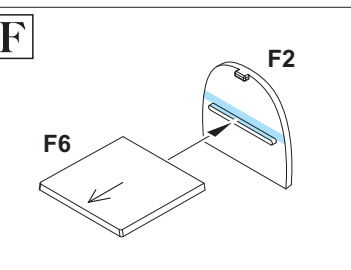
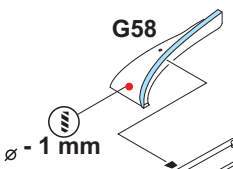
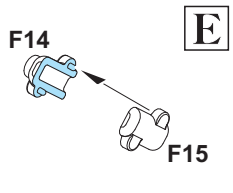
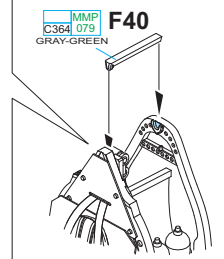
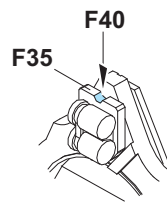
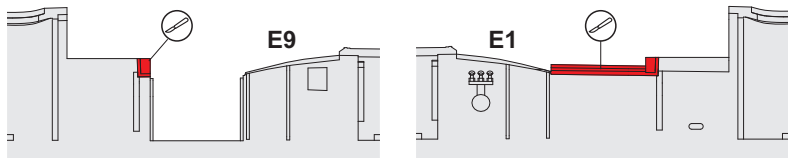

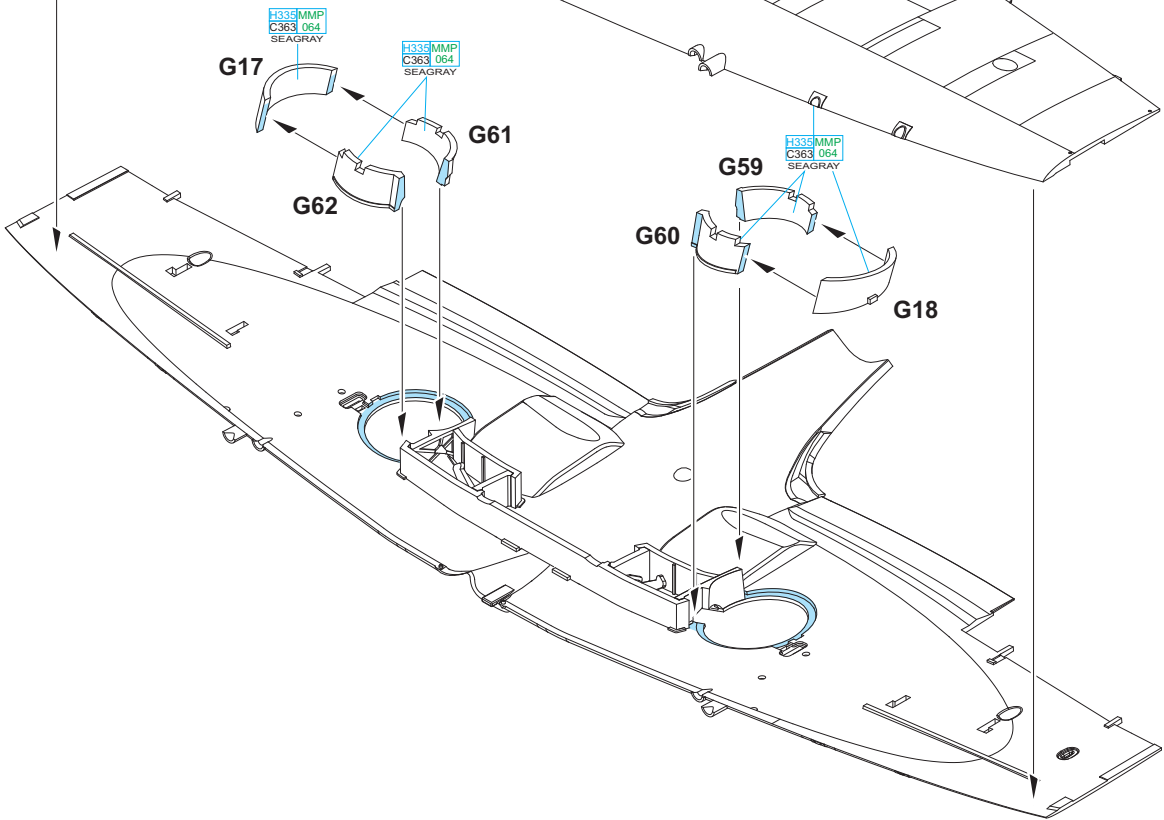
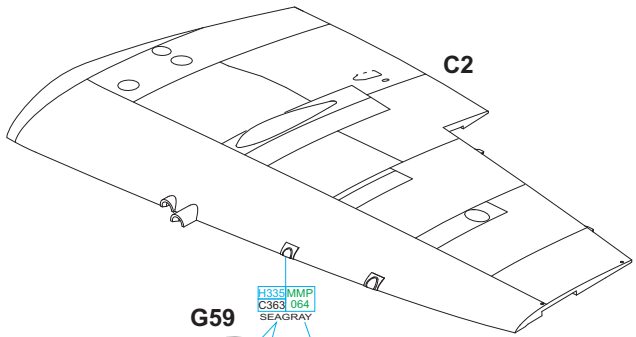
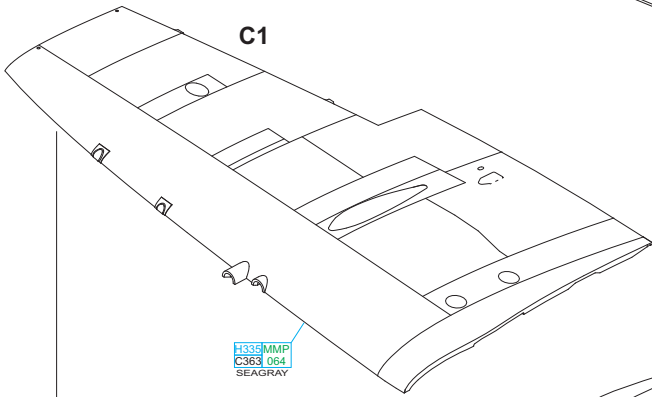
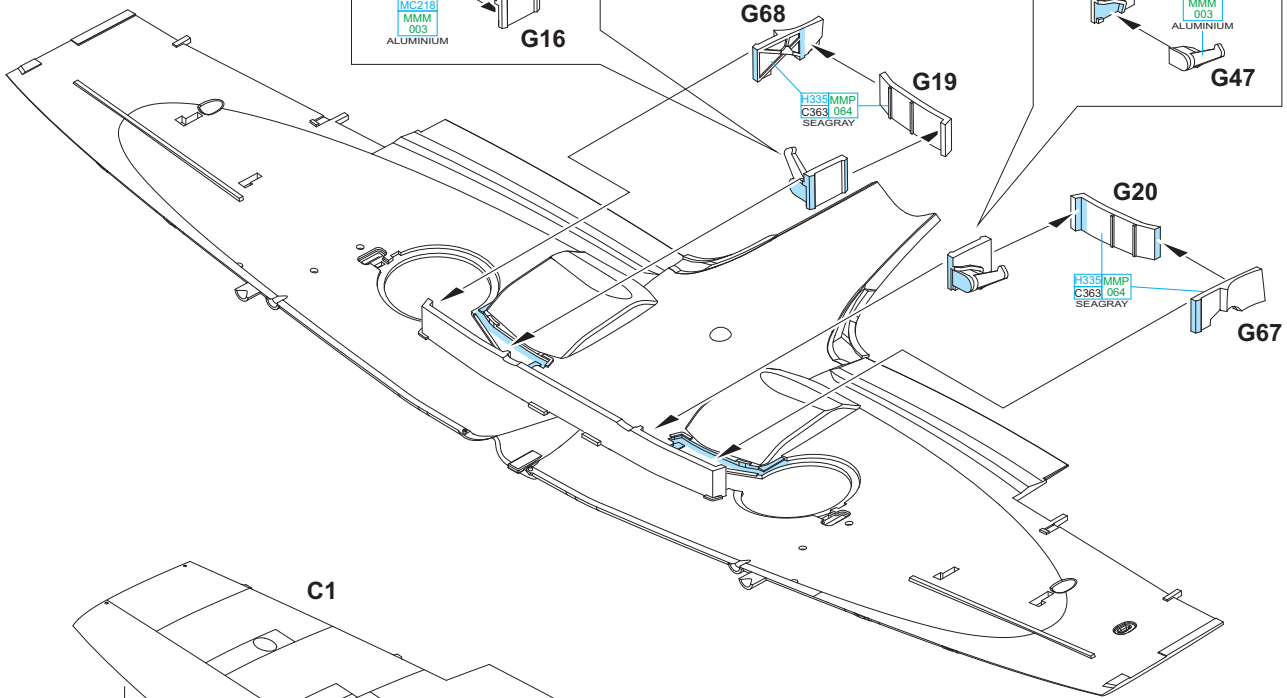
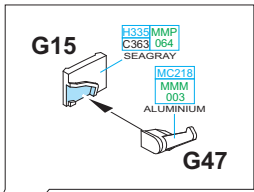
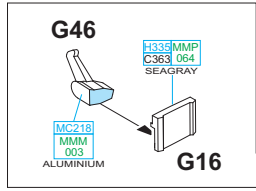

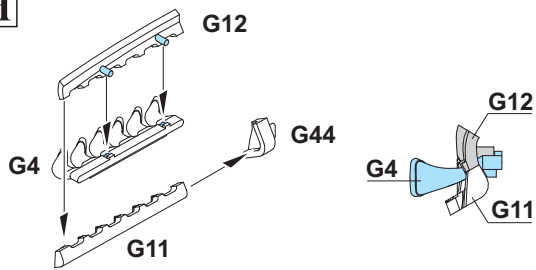
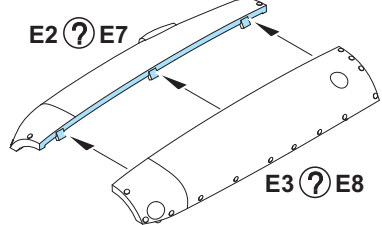
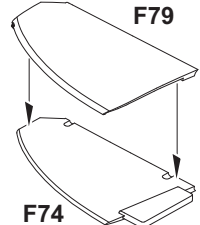
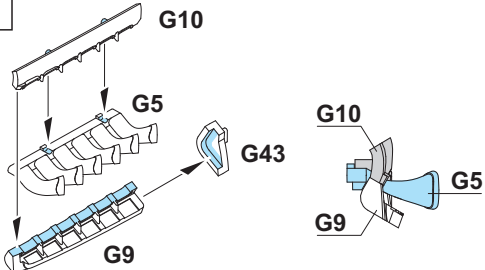
H**I**

E2, E3 - MARKING **A**
 E7, E8 - MARKING **B**

MC214
 MMM
 001
 DARK IRON

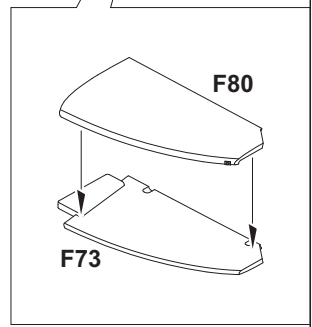
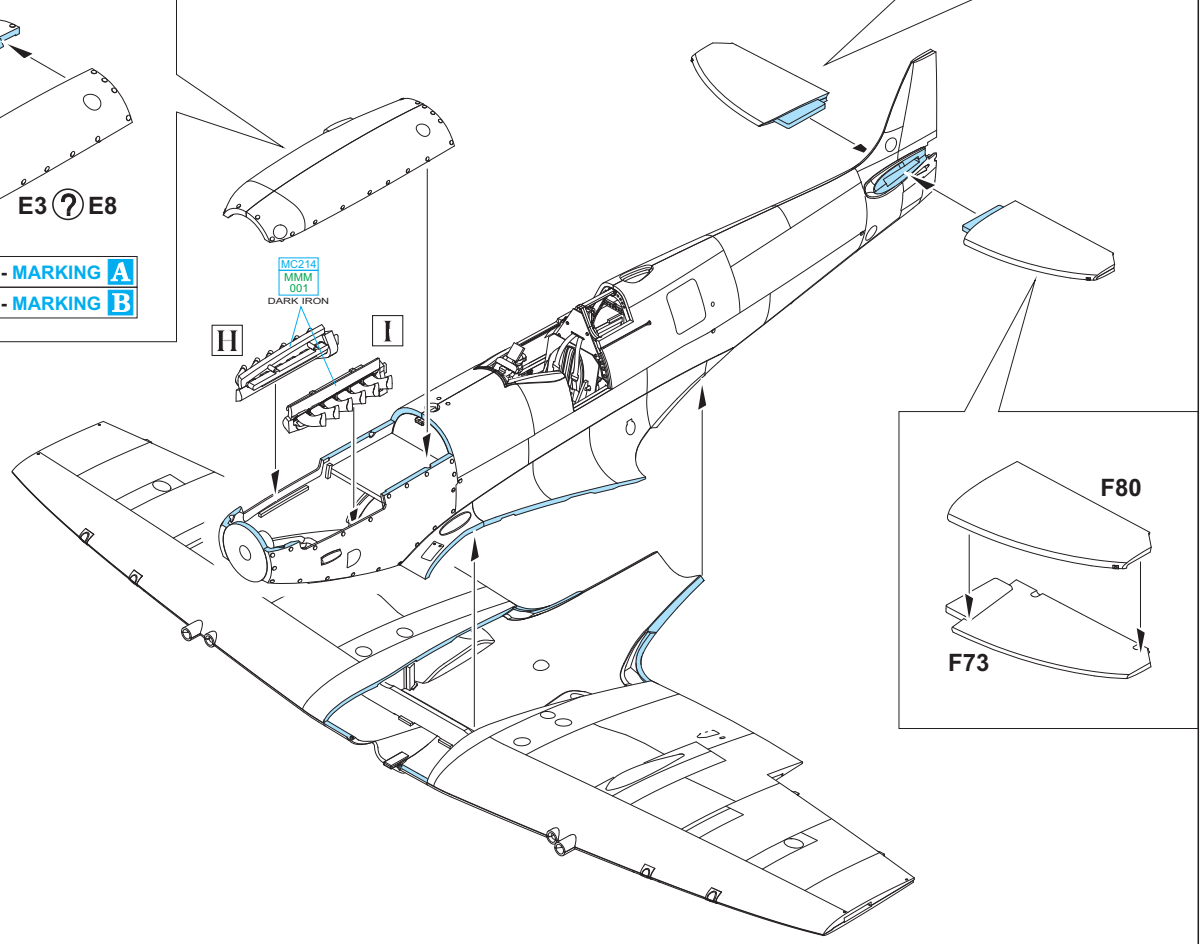

GLUE PARTS F52 & F53
 ONE BY ONE

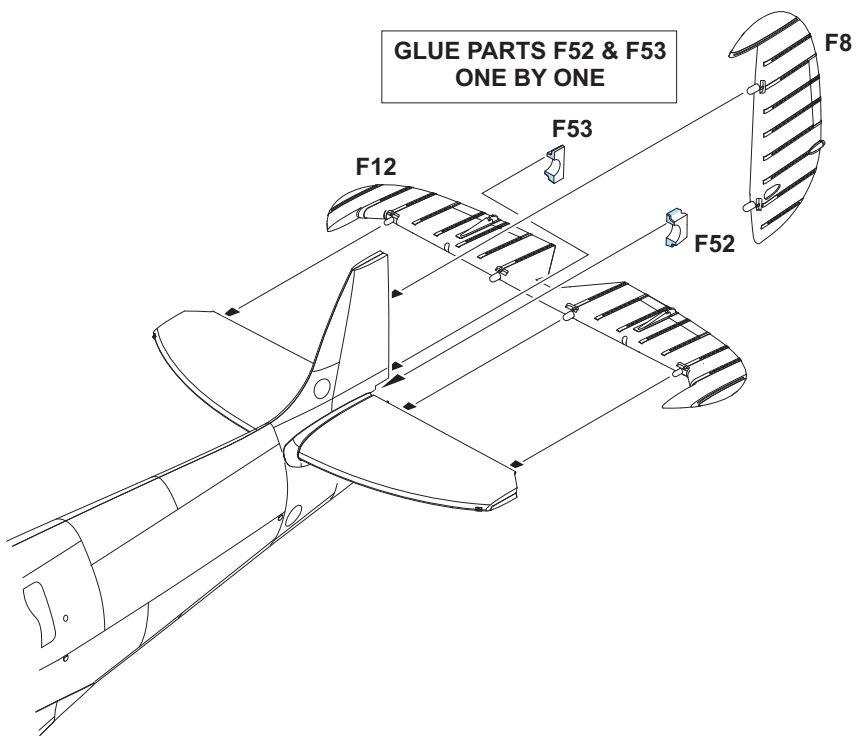

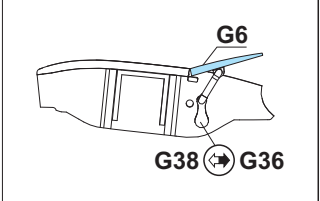
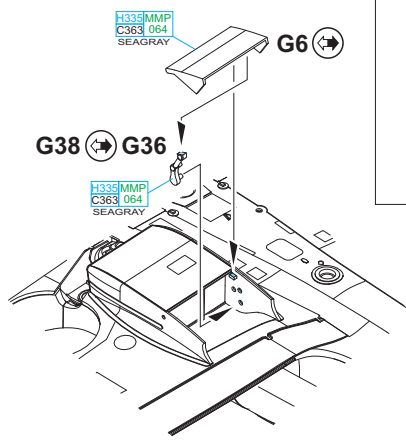
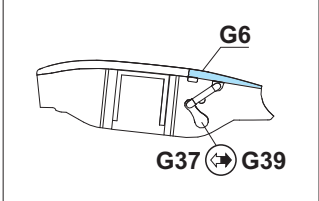
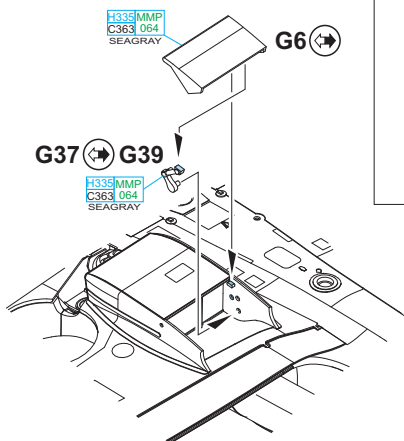
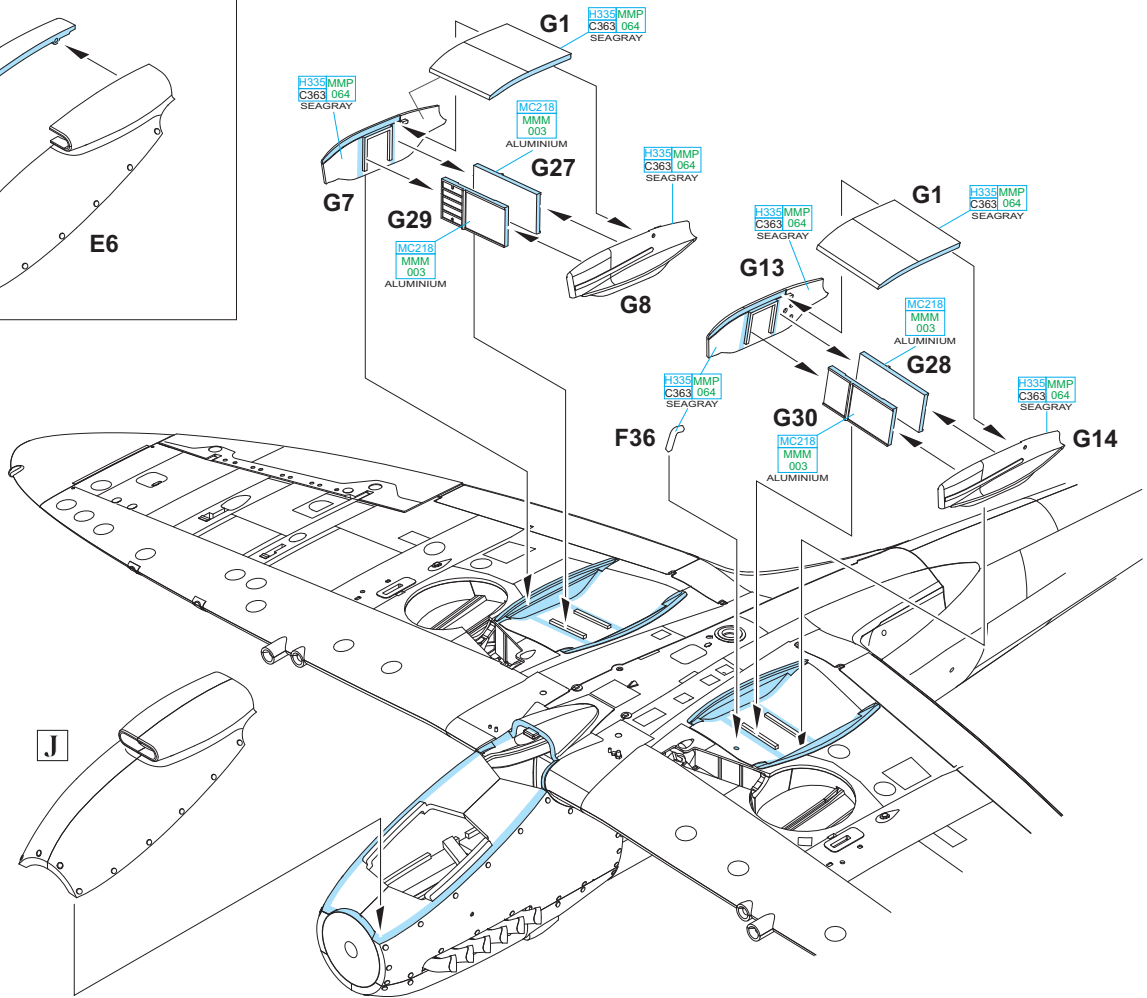
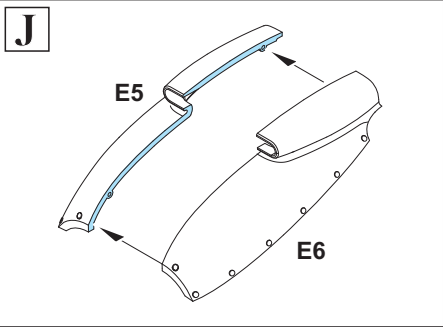
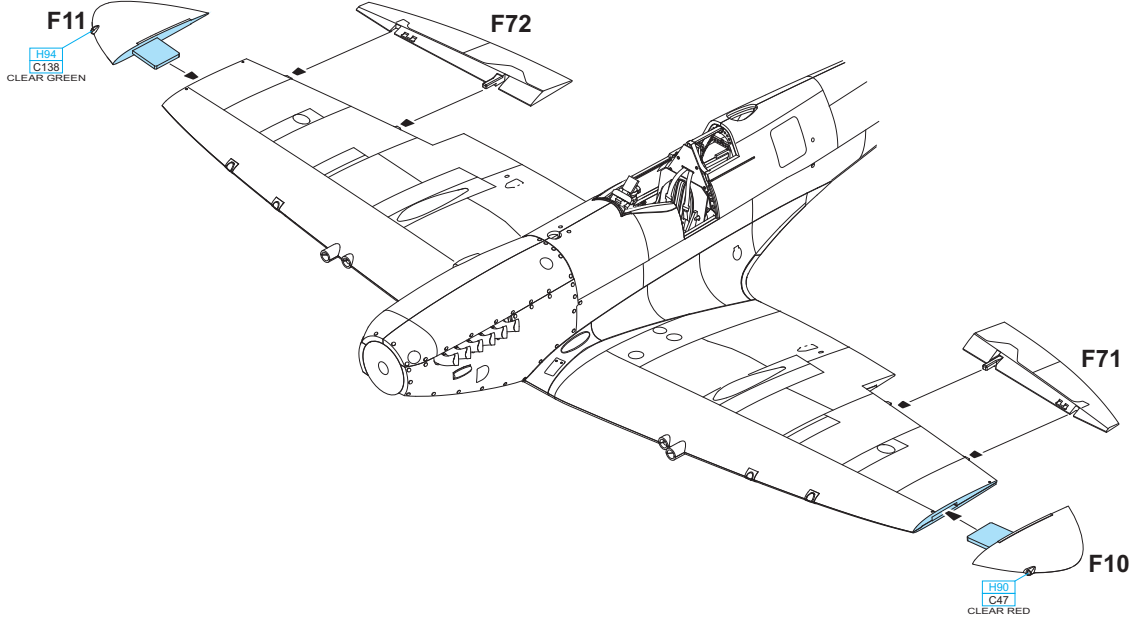

?

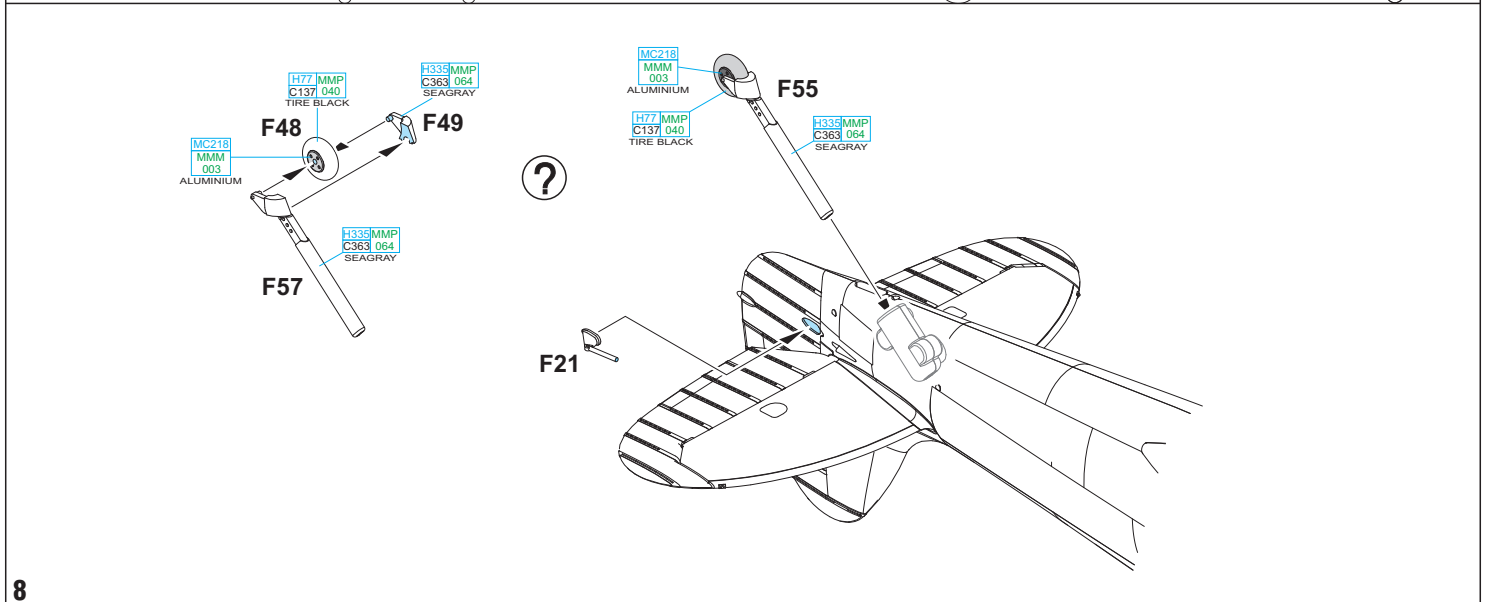
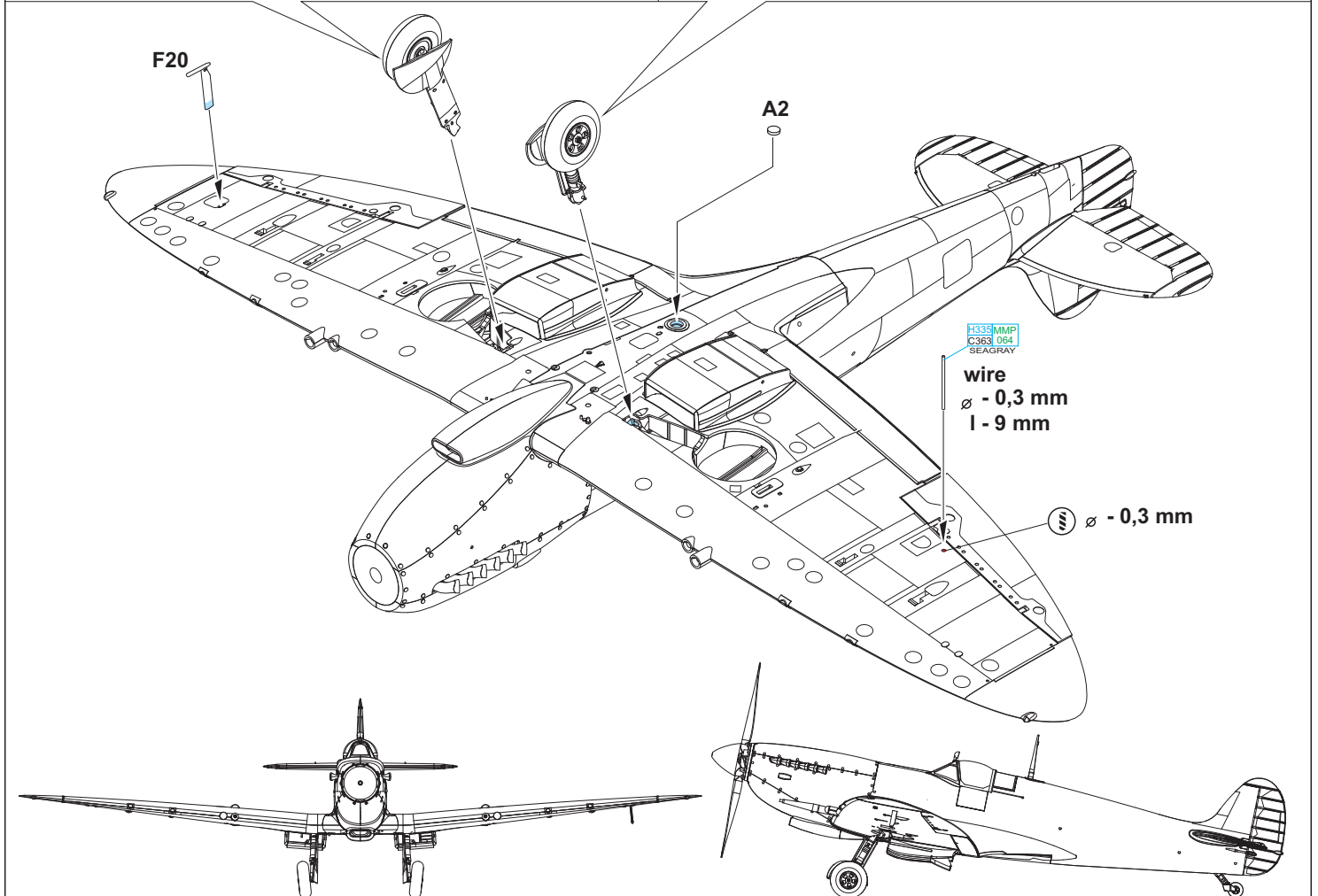
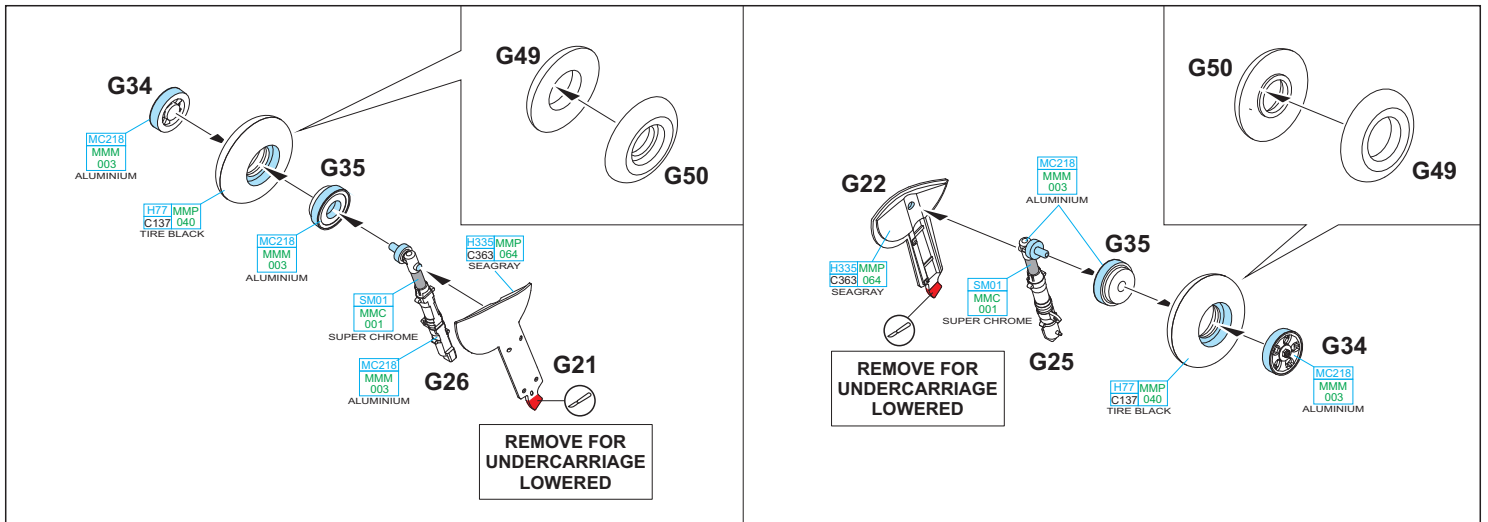

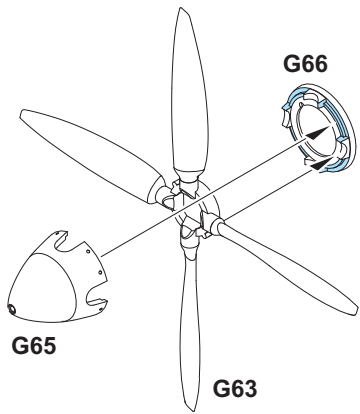
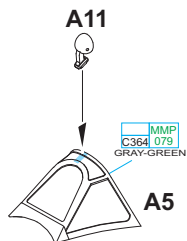
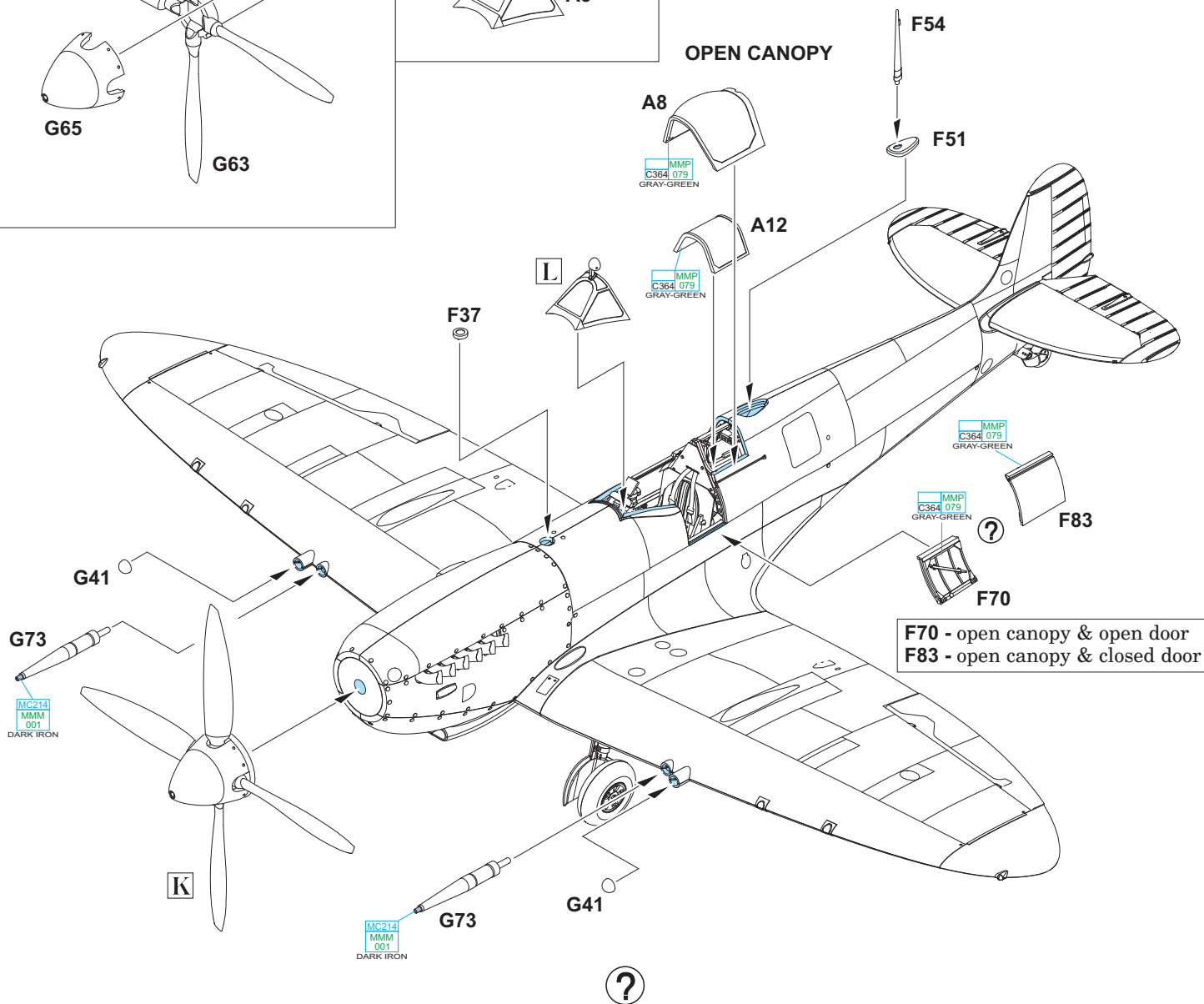
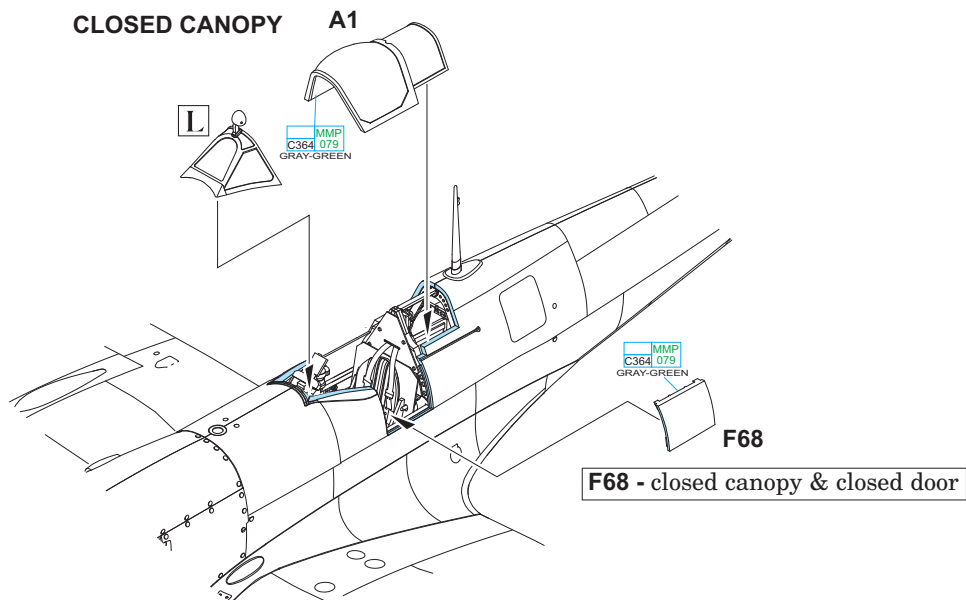
K**L****OPEN CANOPY****CLOSED CANOPY**

A MH763, flown by Prince Emanuel Galitzine, No. 72 Squadron RAF, Ramatuelle Airfield, France, autumn 1944

As can be seen in a period photo, this aircraft landed at Ramatuelle Airfield in southern France. No. 72 Squadron moved to this airfield during Operation Dragoon. MH763 was flown by Prince Emanuel Galitzine, a member of the Russian aristocracy. His family emigrated from Russia to Great Britain and saved their lives from communist murderers. Emanuel Galitzine lived out a very colorful piloting career. He took part in the air defense of Finland against Soviet aggressors. He was accepted by the RAF in 1941 and became famous for his attempt to shoot down a high-flying recce Ju 86R over Southampton on September 12th, 1942. He flew a modified Spitfire for this action. Galitzine served with various units and shot down at least one Fw 190. After the war he worked as a pilot for a civil aviation company.

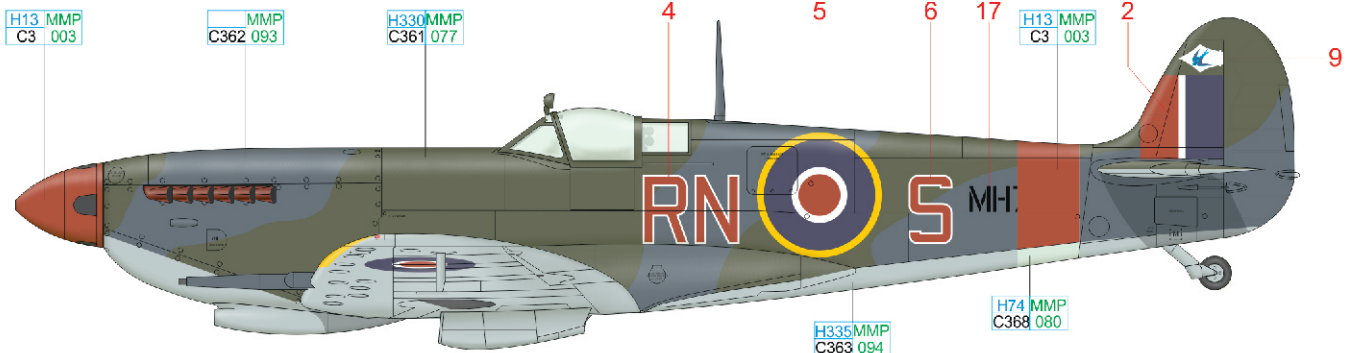

ČESKOU VERZI TEXTU NALEZNETE NA www.eduard.com/s/84151

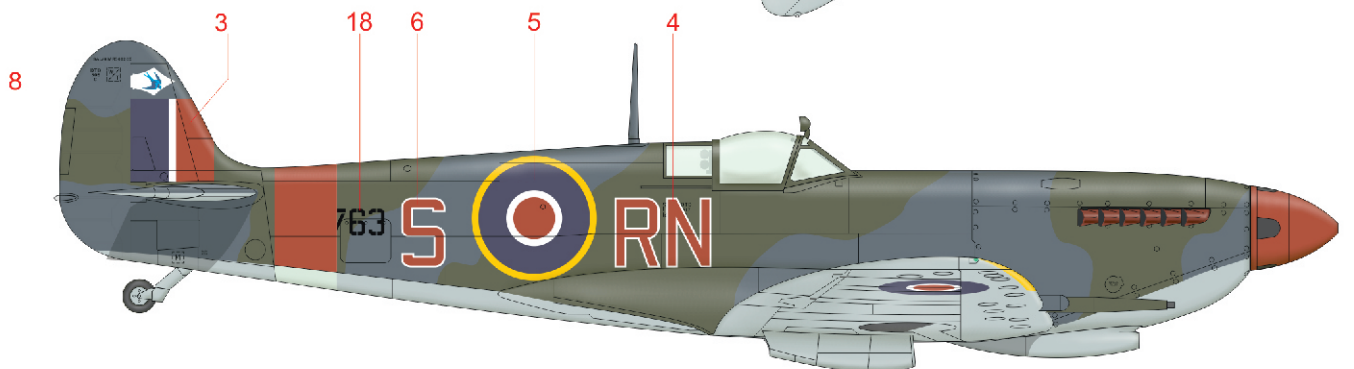
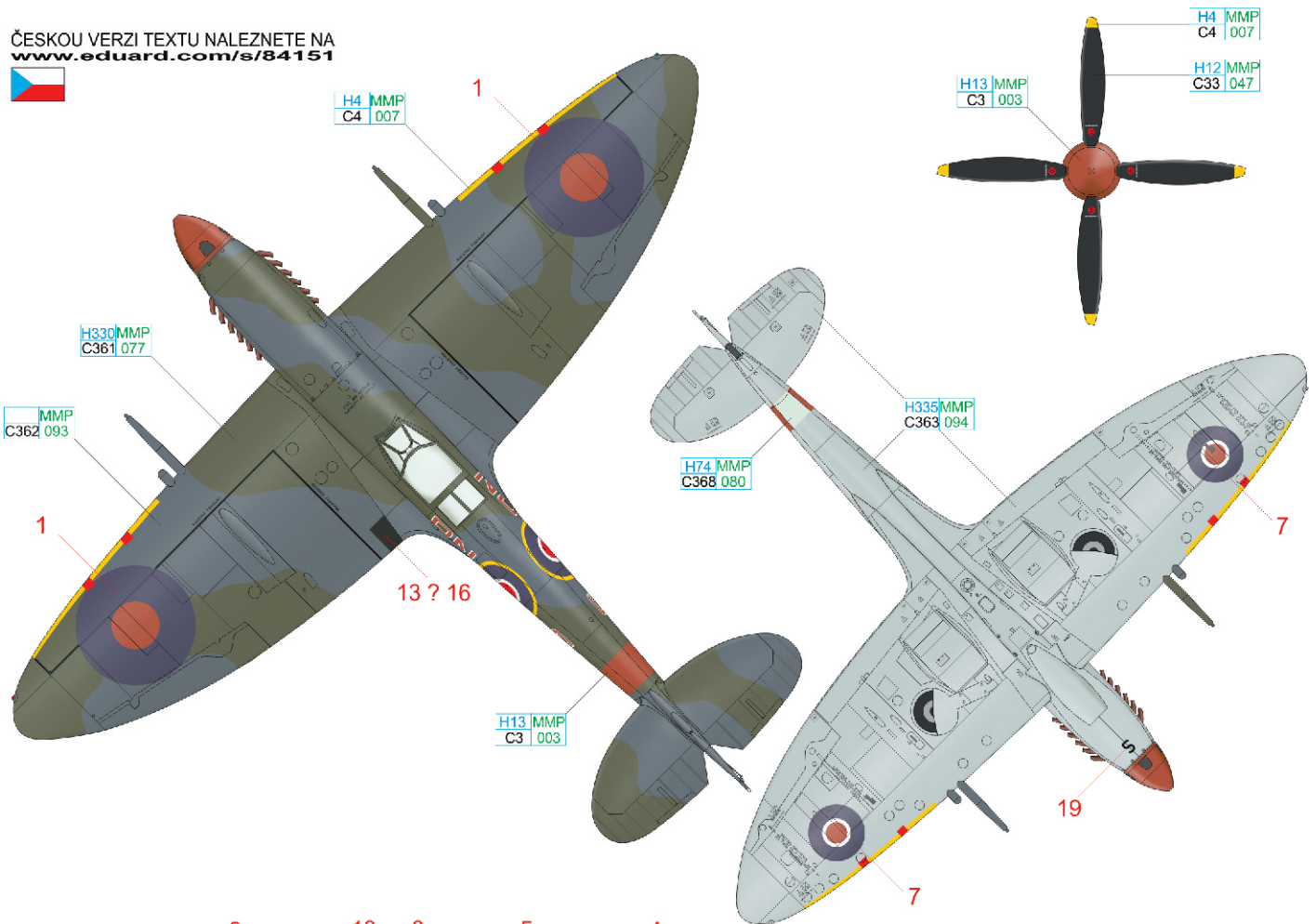

RED	H13 MMP C3 003	YELLOW	H4 MMP C4 007
SKY	H74 MMP C368 080	MEDIUM SEA GRAY	H335 MMP C363 094
OCEAN GRAY	MMP C362 093	DARK GREEN	H330 MMP C361 077
BLACK	H12 MMP C33 047		

eduard

B ML135, flown by Jerry Billing, No. 401 Squadron, France, July 1st, 1944

One of many Canadians in the RAF was Jerry Billing. He volunteered for the RAF in October 1942 to help the Malta defense. He joined No. 185 Squadron and fought over the island until March 1943, when he was downed by a Bf 109 pilot. In 1944 Jerry Billing was sent to No. 401 Squadron. He downed a Ju 88 bomber and damaged two Fw 190s on June 7th, 1944, the second day of the invasion of Normandy. On July 1st, 1944, his Spitfire ML135 was hit by AA fire and landed in no-man's land, 7 miles south of Carentan, France. He managed to get back to the UK with the help of a French family. After WWII, Jerry Billing re-enlisted in the Royal Canadian Air Force and became an instructor. In 1951 he joined the Blue Devils – a Canadian aerobatics team that flew Vampire jets. In 1964 he left the RCAF and took a job at DeHavilland as a test pilot. This aircraft, camouflaged in the standard Dark Green and Ocean Grey upper and side surfaces with Medium Sea Grey lowers, had invasion stripes applied to it that were in quick order reduced to remain on the lower wings only. The side of the fuselage carried the name 'Dorothy'.

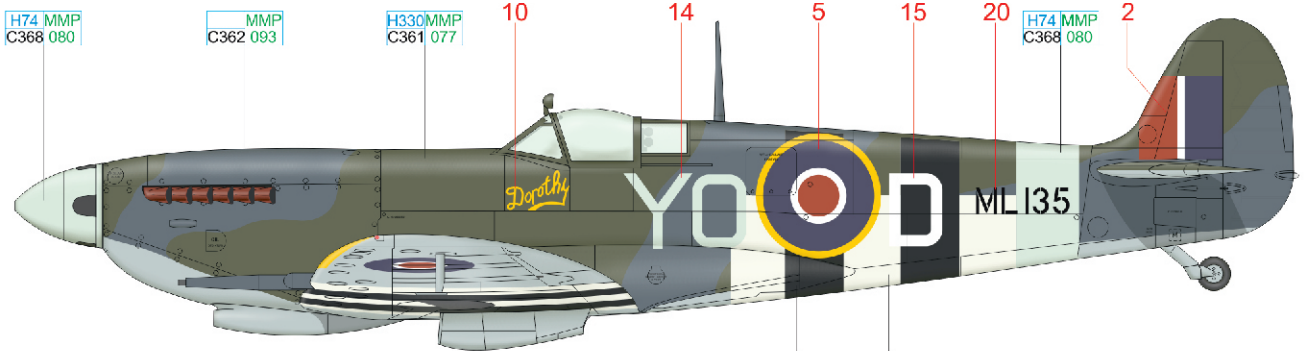

H12 MMP C33 047 H11 MMP C62 001 H4 MMP C4 007 H74 MMP C368 080 H12 MMP C33 047

ČESKOU VERZI TEXTU NALEZNETE NA www.eduard.com/s/84151

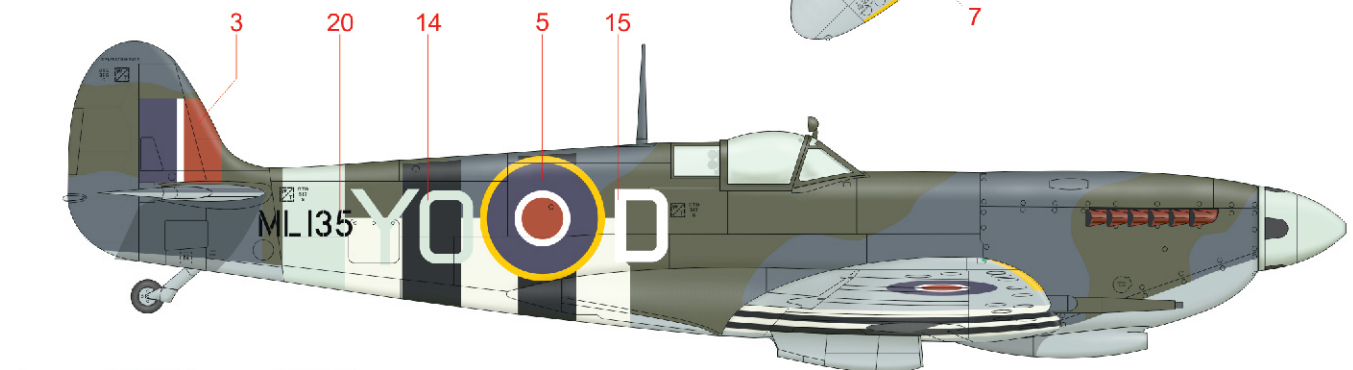
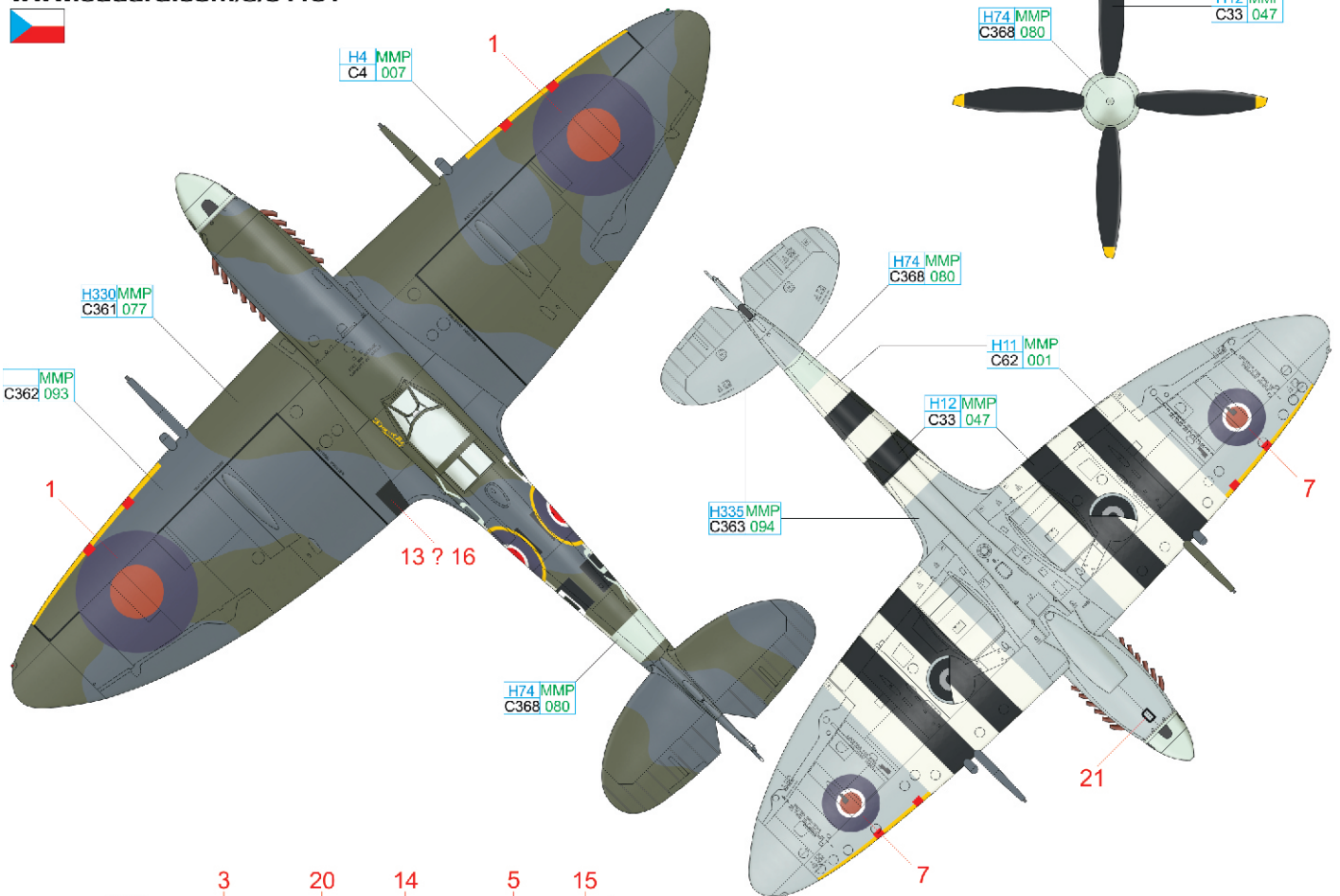

WHITE	H11 MMP C62 001	YELLOW	H4 MMP C4 007
SKY	H74 MMP C368 080	MEDIUM SEA GRAY	H335 MMP C363 094
		OCEAN GRAY	MMP C362 093
		DARK GREEN	H330 MMP C361 077
		BLACK	H12 MMP C33 047

eduard

