

McDonnell Douglas A-4Q Skyhawk 145004
3^o Escuadrilla Aeronaval de Caza y Ataque
Argentina - May/1982

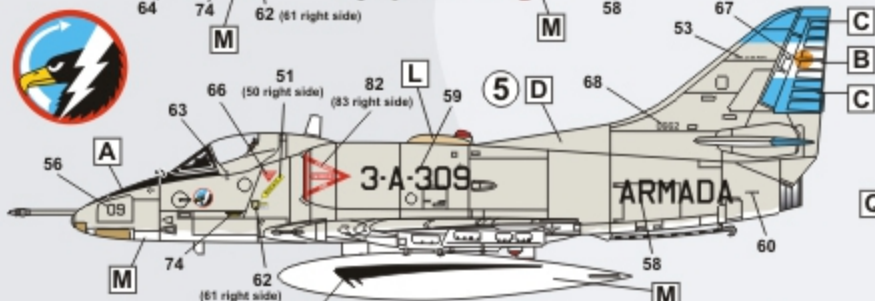

Douglas A-4B Skyhawk C-222 (142752)
Grupo 5 de Caza - 5ta Brigada Aérea
San Luis - Argentina - 1984

Photo References:
Douglas A-4Q Skyhawk
Nuñez Padin - Serie Aeronaval # 11
S. Pedro D'Aldeia Naval Air Base
Alex Sidharta's photo collection

Made in Brazil

fcm
<http://www.fcm.eti.br>

part 1
McDonnell Douglas
A-4 Skyhawk

48
0
44

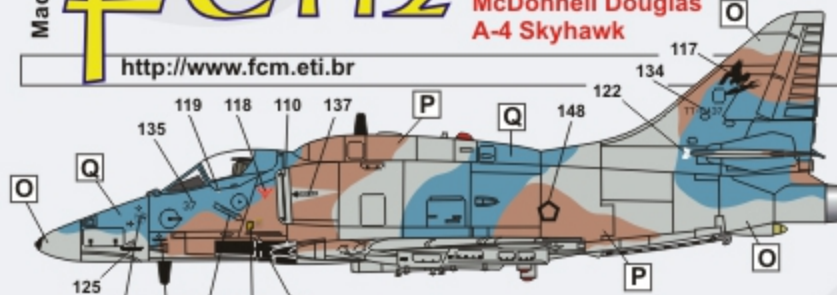

Douglas A-4E Skyhawk 151072
Skadron Udara 11 - Lanud Hasanuddin
Makassar - Indonesia - 2004

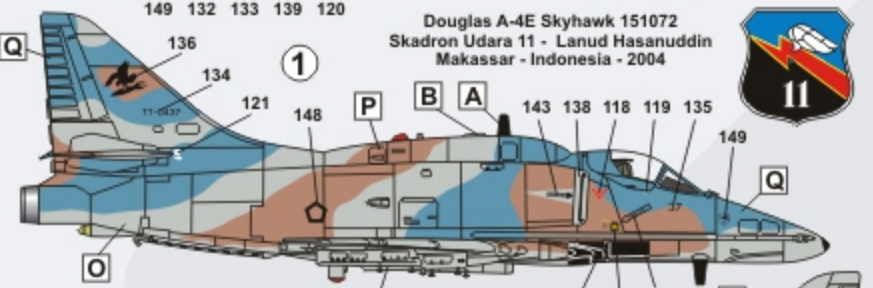

Douglas A-4E Skyhawk 149664
Skadron Udara 11 - Lanud Hasanuddin
Makassar - Indonesia - 1997

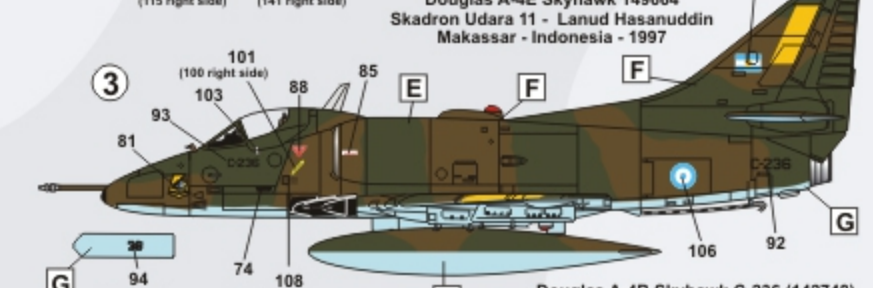

Douglas A-4B Skyhawk C-236 (142748)
Grupo 5 de Caza - BAM Rio Gallegos
Argentina - May 1982

fcmm
48-044

Stencil map for
brazilian AF-1 / AF-1A

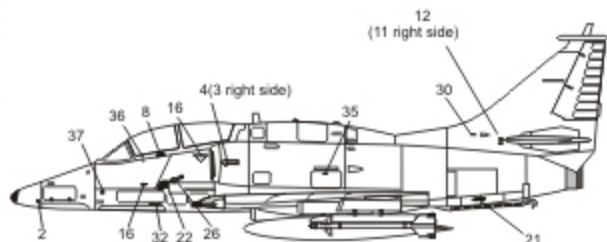

AF-1A

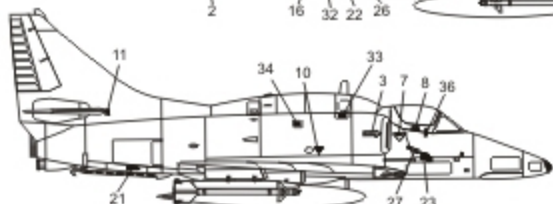

AF-1

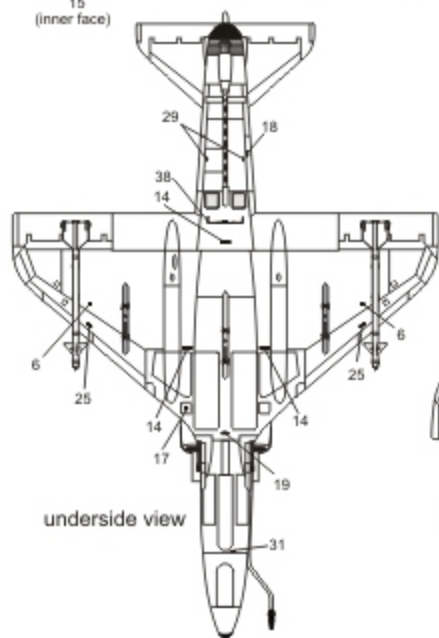
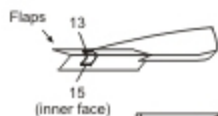

underside view

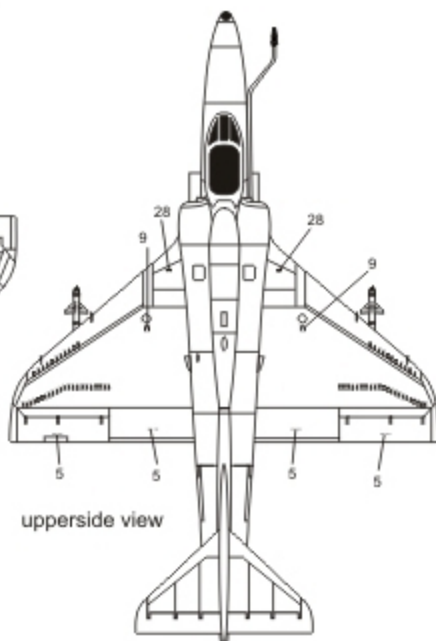

upperside view

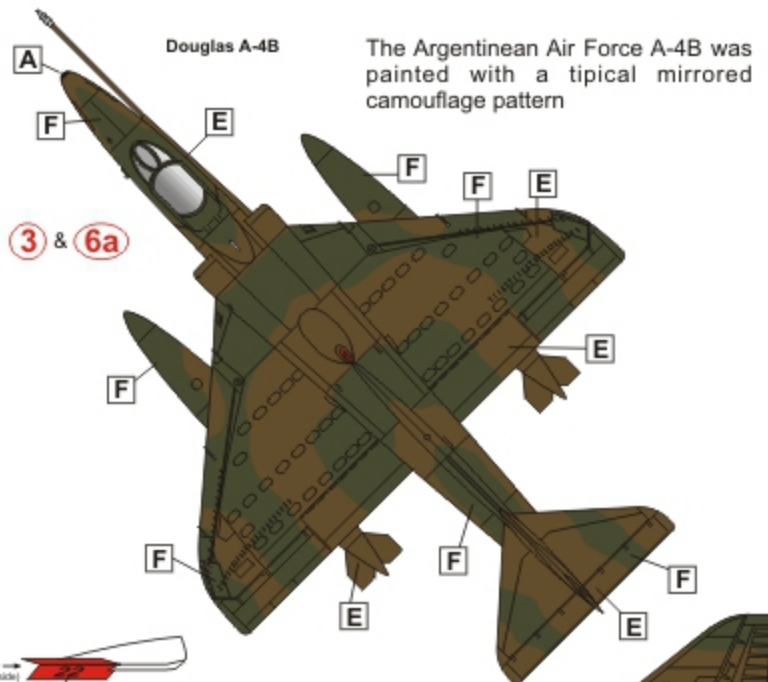

Douglas A-4B

The Argentine Air Force A-4B was painted with a typical mirrored camouflage pattern



Douglas A-4B C-236 seen postwar with five ship kill markings, denoting Grupo 5 tally.

Notes for argentine A-4Bs

- ◆ The yellow bands remained until May 24th
- ◆ All landing gear legs, wells, doors and landing gear bays were painted with the same underside color.

Special thanks to **Jorge Raúl Figari** for his support with argentinean A.F. color schemes.

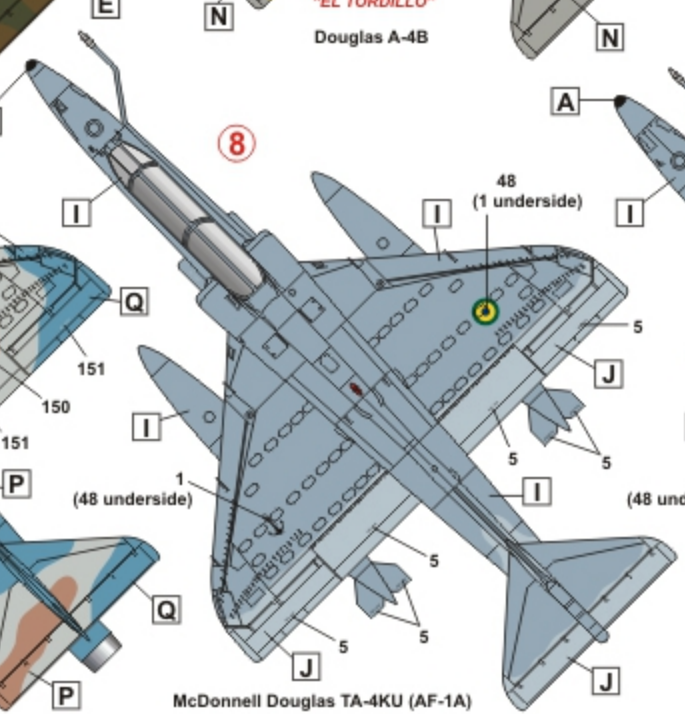
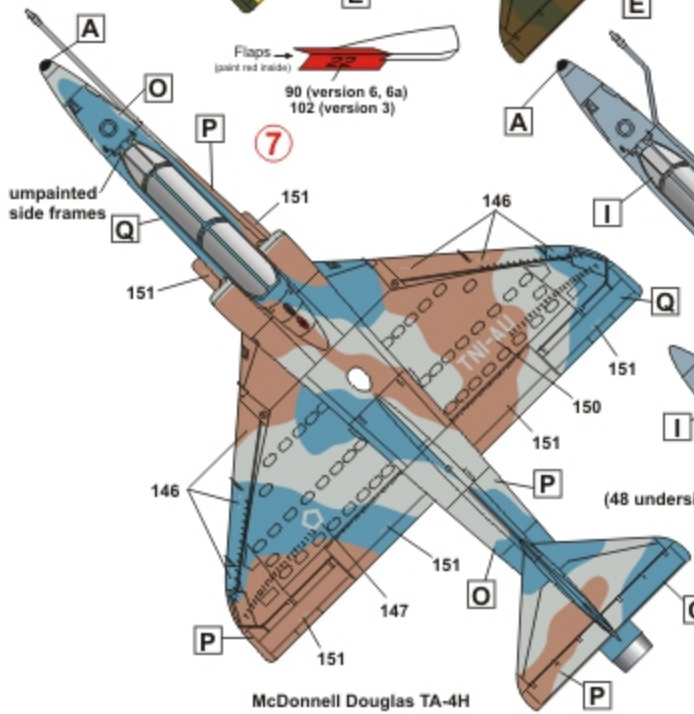
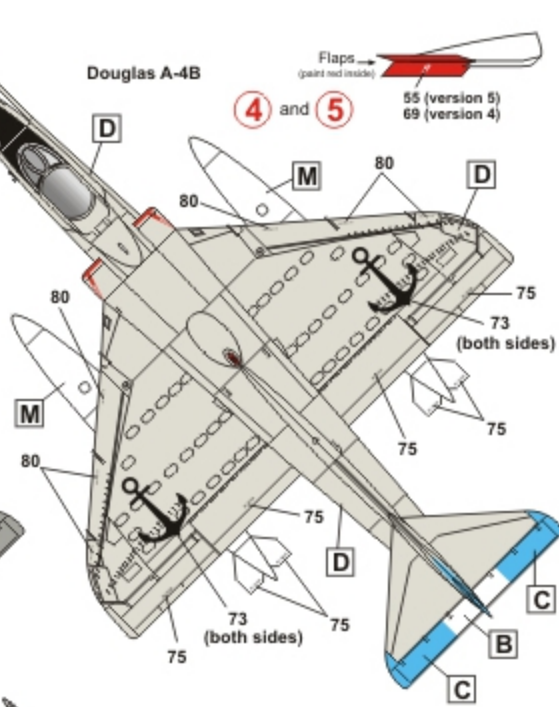
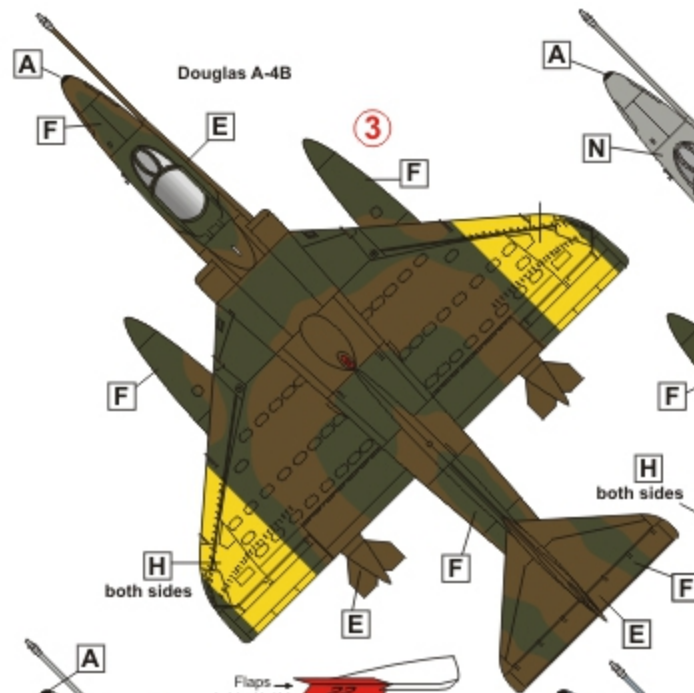

Stencil map for
brazilian AF-1 / AF-1A

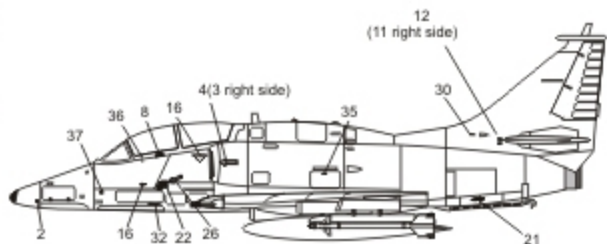

AF-1A

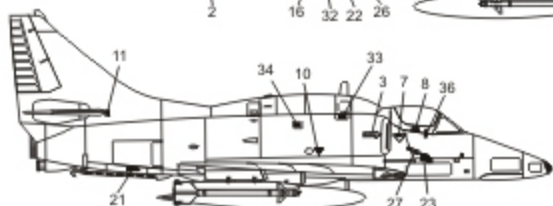

AF-1

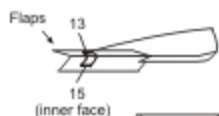

Flaps
15
(inner face)

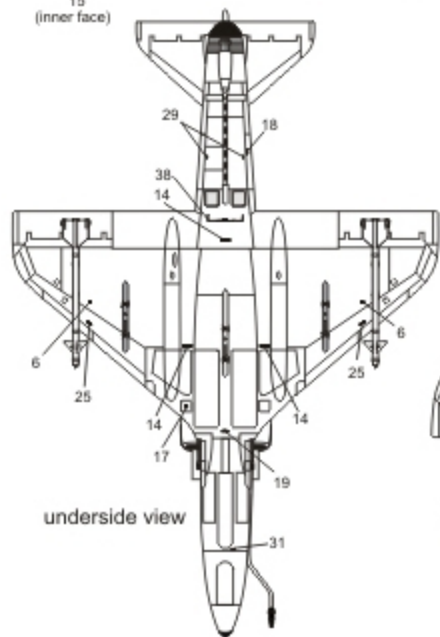

underside view

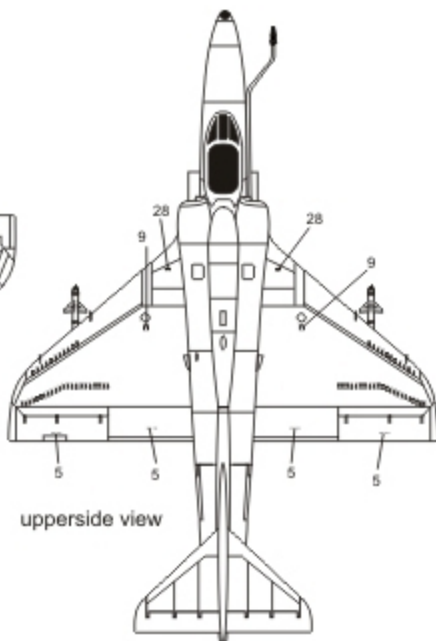

upperside view

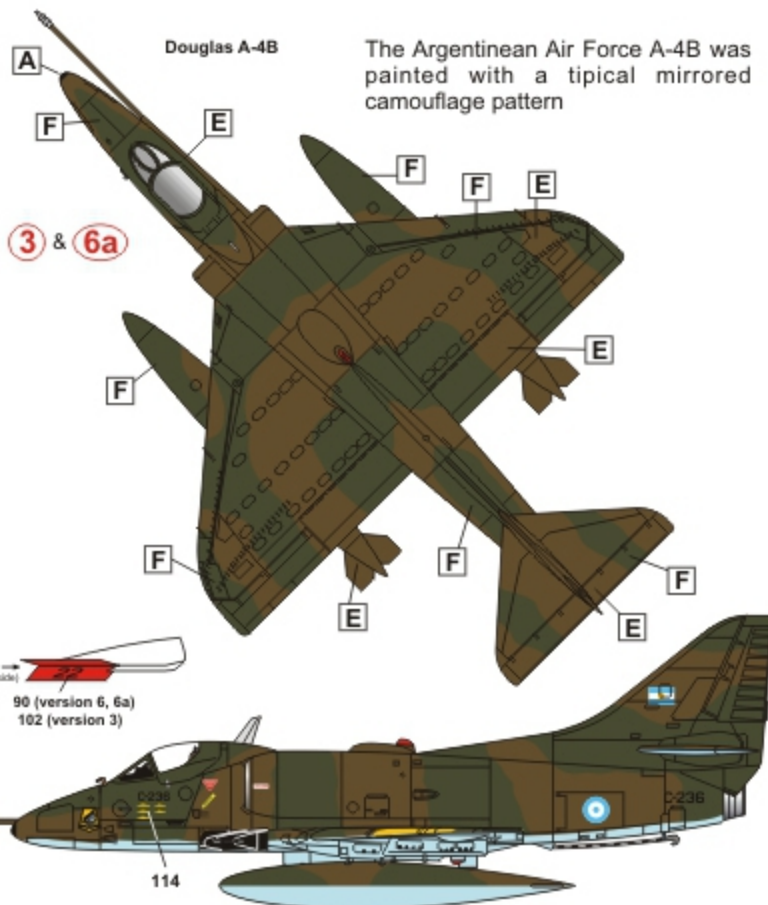

Douglas A-4B

The Argentine Air Force A-4B was painted with a typical mirrored camouflage pattern

3 & 6a

Flaps
(paint red inside)
90 (version 6, 6a)
102 (version 3)

114

Douglas A-4B C-236 seen postwar with five ship kill markings, denoting Grupo 5 tally.

Notes for argentine A-4Bs

- ◆ The yellow bands remained until May 24th
- ◆ All landing gear legs, wells, doors and landing gear bays were painted with the same underside color.

Special thanks to **Jorge Raúl Figari** for his support with argentinean A.F. color schemes.