

STEP 1 THIS PRR POSITION LIGHT SIGNAL HEAD IS DESIGNED TO BE POPULATED WITH INDIVIDUAL 603 SMD LEDs. THESE ARE SOLD SEPARATELY ON OUR WEBSITE AND CAN BE PURCHASED IN ANY STANDARD ASPECT COLOR. THEY COME SOLDERED WITH FINE, 40 AWG WIRE FOR EASY ROUTING INTO THE SIGNAL HEAD OPENINGS AND MAST. LEDs SHOULD BE INSTALLED WITH CANOPY GLUE IN THE ASPECT HEADS. FRONT OPENINGS IN THE SIGNAL HEAD CAN BE FILLED WITH KRYSTAL KLEAR TO CREATE A "LENS" FOR THE ASPECT. **FIG.2**

NOTE: WE RECOMMEND TESTING THE LEDs BEFORE INSTALLING USING A MIN OF 1K RESISTOR

STEP 2 ONCE THE LEDs HAVE BEEN INSTALLED AND THE WIRE LEADS HAVE BEEN ROUTED TO THE CENTER OF THE SIGNAL HEAD, PROCEED TO ROUTE THE WIRE BUNDLE THROUGH THE REAR HOLE IN THE MOUNT (PART C). ATTACH THE MOUNT TO THE SIGNAL HEAD MAKING SURE THE LED WIRE LEADS EXIT AS A BUNDLE THROUGH THE MOUNT. **FIG.3**

STEP 3 USING CANOPY GLUE, ATTACH THE SIGNAL BACKS TO THE BACK OF EACH SIGNAL ASPECT. DRILL A .040" HOLE (MINIMUM) IN THE SIGNAL MAST AT THE MOUNTING POINT FOR THE SIGNAL HEAD. SMOOTH THE INSIDE EDGES OF THE DRILLED HOLE WITH A DIAMOND NEEDLE FILE TO PREVENT SCUFFING THE LED WIRE LEADS AS THEY ARE ROUTED THROUGH THE HOLE AND DOWN THE MAST TUBE. **FIG.5**

STEP 4 ASPECT BLACK-OUT COVERS ARE PROVIDED AS AN OPTION FOR COVERING OPENINGS IN THE SIGNAL HEAD SHIELD. IF THESE COVERS ARE USED, THE SMALL ASPECT HOODS MUST BE CAREFULLY CUT OFF AND FILED DOWN SMOOTH WITH THE SIGNAL HEAD FACE. **FIG.6**

PARTS

PLEASE READ THROUGH THE ENTIRE ASSEMBLY STEPS TO FAMILIARIZE YOURSELF WITH THE PARTS AND METHODS WE RECOMMEND.

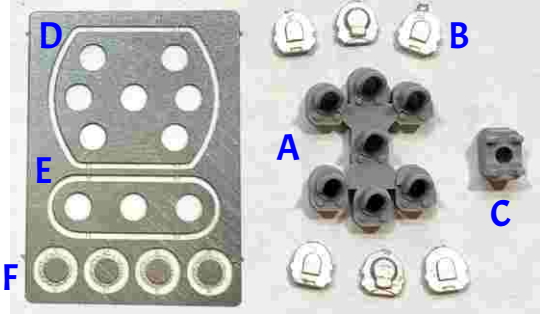

WE RECOMMEND ASSEMBLING WITH SUPER GLUE UNLESS OTHERWISE NOTED

FIG. 1

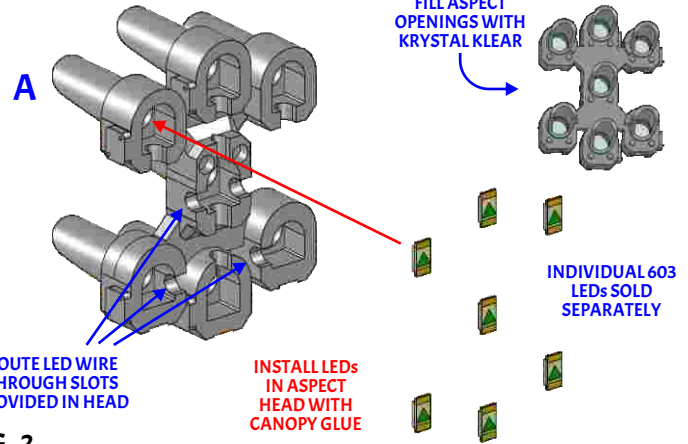

FIG. 2

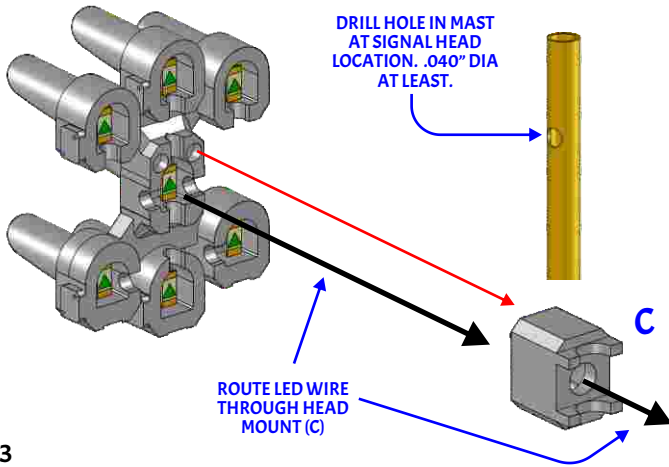

FIG. 3

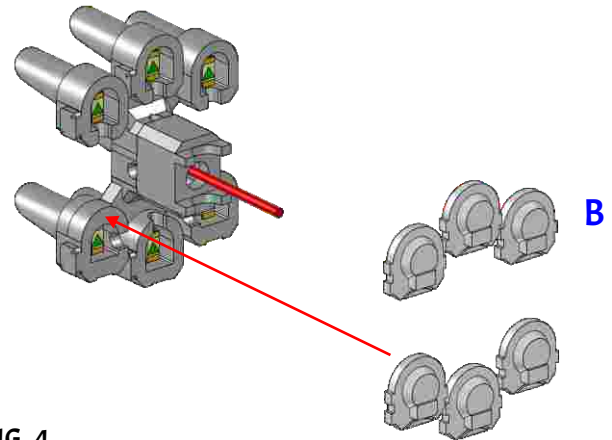

FIG. 4

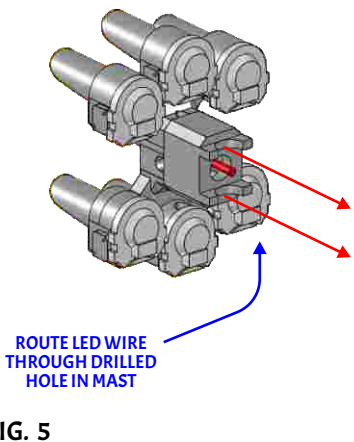

FIG. 5

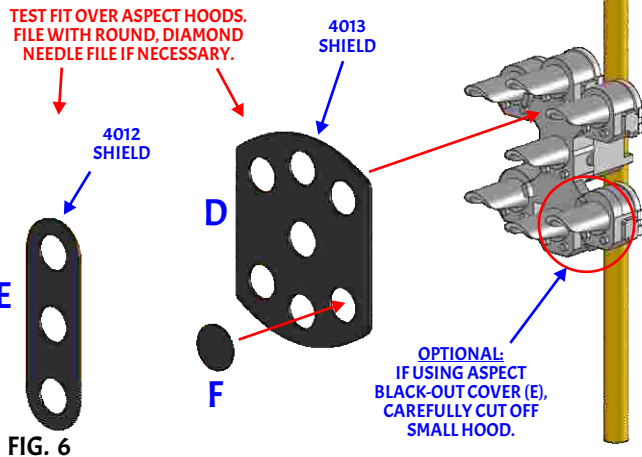

FIG. 6

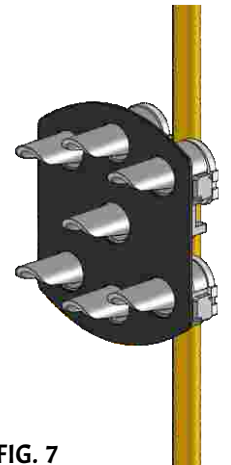

FIG. 7