

Highly recommended reference material:

-SUPER CARRIERS /J.P.Montbazer  
-SEVENTH FLEET SUPER CARRIERS  
/Tony Holmes

Both from Osprey Publishing Ltd./ London

-Koku Fan monthly magazine (several)

-75 Years of US Navy aviation /  
Koku Fan Illustrated Nº34

All from Bunrin Do Co Ltd/Tokyo

Caution  
This kit can only be assembled using  
cyanoacrylate glue.  
Work in well-ventilated areas only.

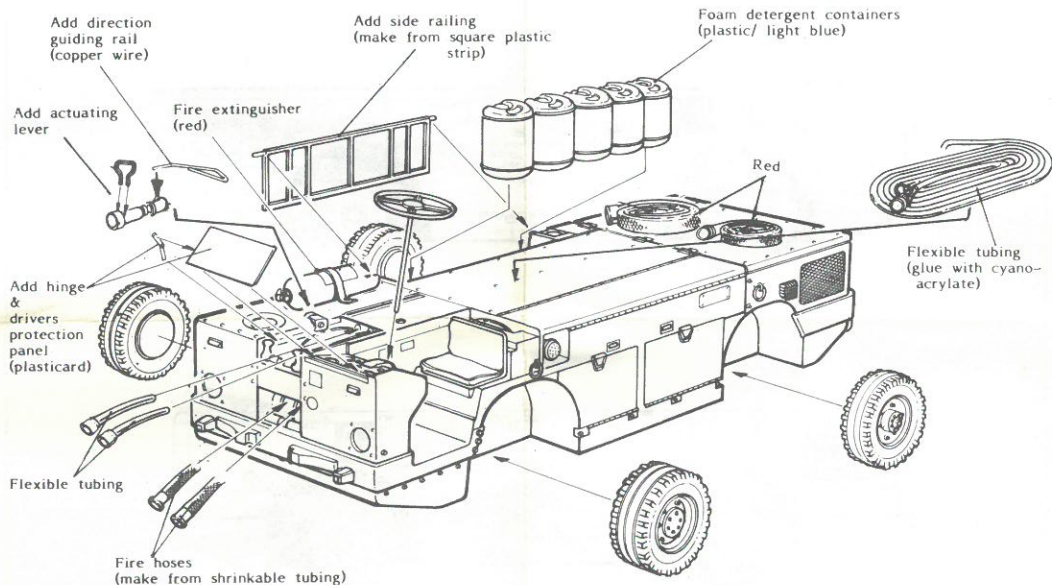

Hand hold  
(make from rod)

Platform in  
closed position

Hand hold  
(rod)

This type of fire tractor will soon replace all Oshkosh fire trucks (still in use on some carriers) because of it's relative small size compared to the large Oshkosh.

# Painting & Markings

Apply markings as indicated

Some tractors are white overall with a red band running from the top rear to the bottom front. Others have been seen in overall yellow with the red band running from top front to bottom rear. The markings shown here are for a white tractor of the first description.

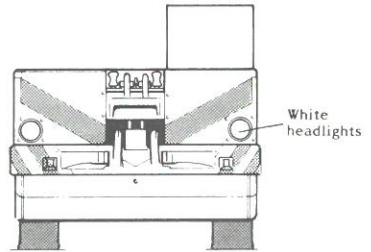
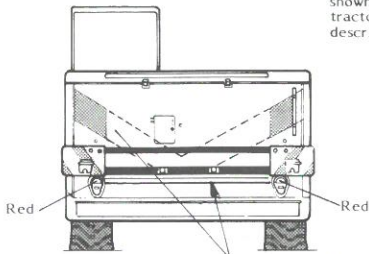

Red band continues on the outside of the standing platform (sometimes on tractor rear as well)

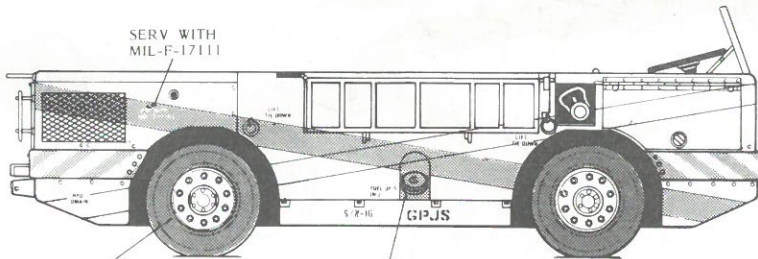
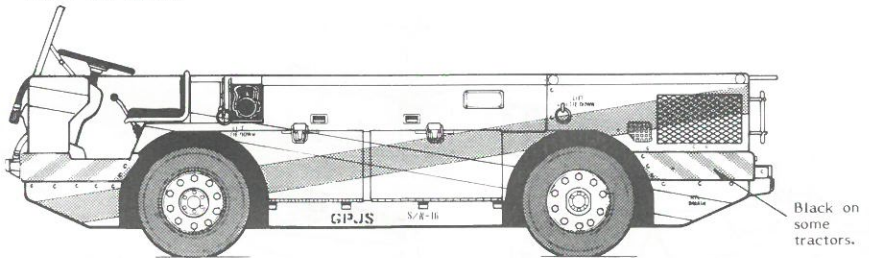

Tyres are best painted Dark Grey instead of Black

Black or Light Grey anti-skid surface

Black or Dark Grey

Black/White dials

